

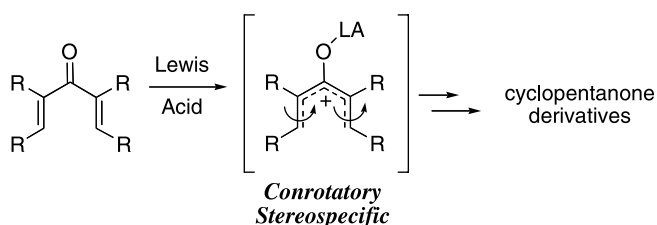
Contents

REPORT

**The Nazarov cyclization in organic synthesis. Recent advances**

pp 7577–7606

Alison J. Frontier\* and Christina Collison



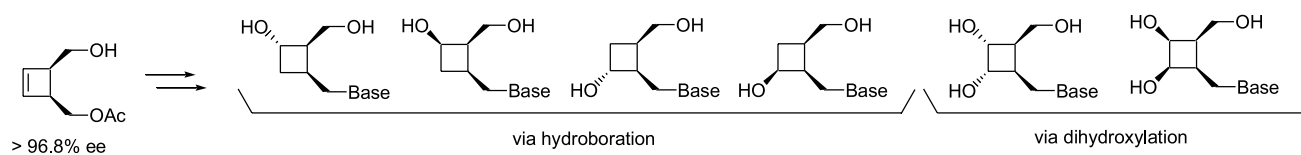
Recent synthetic advancements involving the Nazarov electrocyclicization are reviewed. Aspects of reactivity and stereochemistry are discussed, as well as the continuing development of the methodology for application to natural product synthesis.

ARTICLES

**Synthesis of mono- and polyhydroxylated cyclobutane nucleoside analogs**

pp 7607–7612

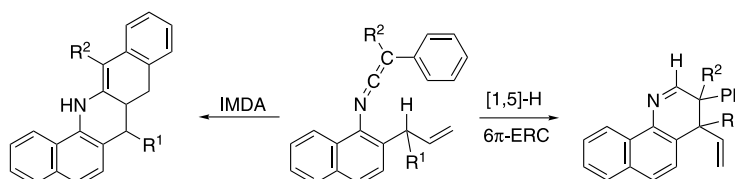
Yoann Marsac, Arnaud Nourry, Stéphanie Legoupy,\* Muriel Pipelier, Didier Dubreuil, Anne-Marie Aubertin, Nathalie Bourgougnon, Rachid Benhida and François Huet\*



**Thermal cyclization of *N*-[2-(2-propenyl)-1-naphthyl] ketenimines: intramolecular Diels–Alder reaction versus [1,5] hydrogen migration. Synthesis of dibenz[*b,h*]acridines and benzo[*h*]quinolines**

pp 7613–7621

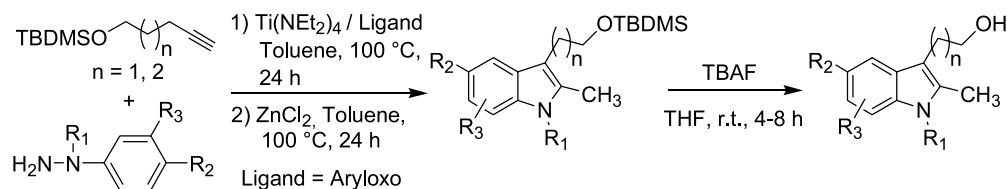
Mateo Alajarín,\* Ángel Vidal\* and María-Mar Ortín



**Convenient synthesis of tryptophols and tryptophol homologues by hydroamination of alkynes**

pp 7622–7631

Vivek Khedkar, Annegret Tillack, Manfred Michalik and Matthias Beller\*

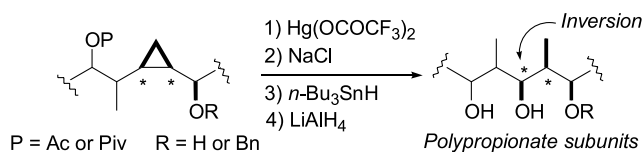


The first general method for the synthesis of tryptophol derivatives from aryl hydrazines and alkynes is presented.

**Synthesis of polypropionate subunits from cyclopropanes**

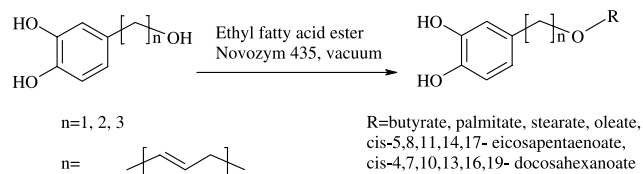
pp 7632–7653

Magali Defosseux, Nicolas Blanchard, Christophe Meyer and Janine Cossy\*

**Efficient lipase-catalyzed synthesis of new lipid antioxidants based on a catechol structure**

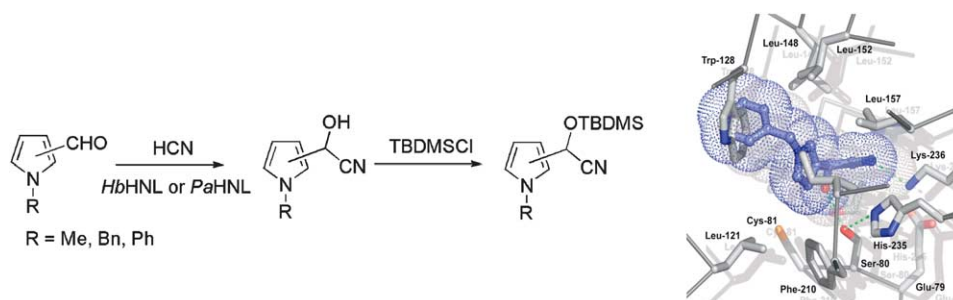
pp 7654–7660

A. Torres de Pinedo, P. Peñalver, D. Rondón and J. C. Morales\*

**Asymmetric biocatalytic hydrocyanation of pyrrole carboxaldehydes**

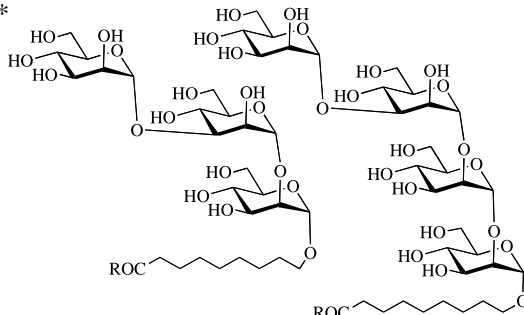
pp 7661–7668

Thomas Purkarthofer, Karl Gruber, Martin H. Fechter and Herfried Griengl\*



**Synthetic yeast oligomannosides as biological probes:  $\alpha$ -D-Manp (1  $\rightarrow$  3)  $\alpha$ -D-Manp (1  $\rightarrow$  2)  $\alpha$ -D-Manp and  $\alpha$ -D-Manp (1  $\rightarrow$  3)  $\alpha$ -D-Manp (1  $\rightarrow$  2)  $\alpha$ -D-Manp (1  $\rightarrow$  2)  $\alpha$ -D-Manp as Crohn's disease markers** pp 7669–7677

Reynald Chevalier, Jacques Esnault, Peggy Vandewalle, Boualem Sendid, Jean-Frédéric Colombel, Daniel Poulain and Jean-Maurice Mallet\*

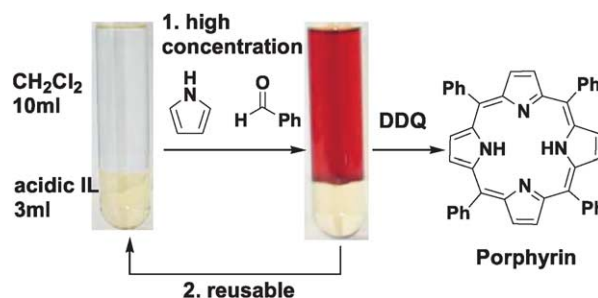


**Ionic liquids for tetraarylporphyrin preparation**

Satoshi Kitaoka, Kaoru Nobuoka and Yuichi Ishikawa\*

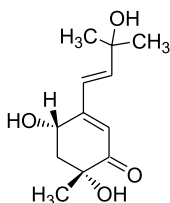
pp 7678–7685

Ionic liquids are instrumental enough to shift-up the TPP-family preparation into a 'Green' process from heavy consumer of a harmful halogenated solvent.



**Acremines A–F, novel secondary metabolites produced by a strain of an endophytic *Acremonium*, isolated from sporangiophores of *Plasmopara viticola* in grapevine leaves** pp 7686–7692

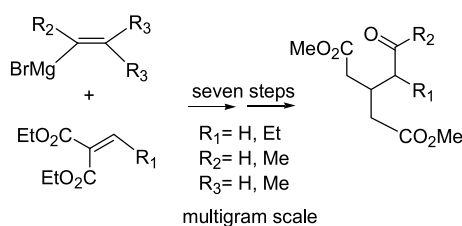
Gemma Assante, Sabrina Dallavalle,\* Luciana Malpezzi, Gianluca Nasini,\* Santella Burruano and Livio Torta



**Synthesis of 3-acetyl- and 3-(2-oxoethyl)glutarates**

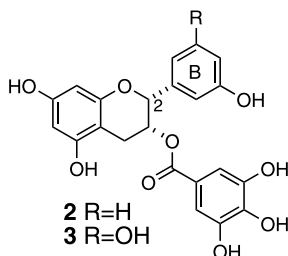
Mercedes Amat, Oriol Bassas, Margalida Cantó, Núria Llor, Maria M. M. Santos and Joan Bosch\*

pp 7693–7702



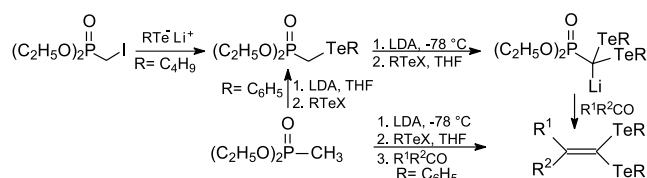
### Asymmetric total synthesis of B-ring modified (–)-epicatechin gallate analogues and their modulation of $\beta$ -lactam resistance in *Staphylococcus aureus* pp 7703–7711

James C. Anderson,\* Catherine Headley, Paul D. Stapleton and Peter W. Taylor\*



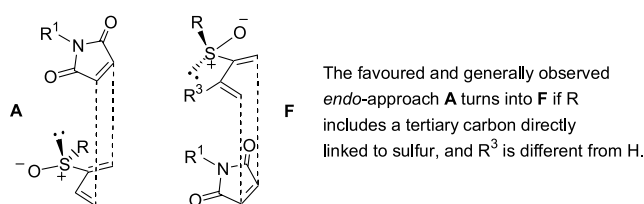
### Synthesis of ketene phenyl- and butyltelluroacetals by a Horner–Wittig route pp 7712–7718

Claudio C. Silveira,\* Rodrigo Cella, Antonio L. Braga, Raquel G. Jacob, Eder J. Lenardão and Gelson Perin\*



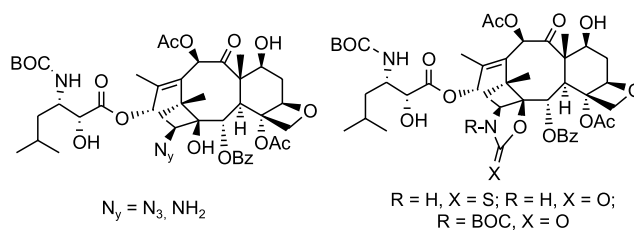
### Maleimide cycloadditions by sulfinyldienes: is the sulfur configuration the only controller of the diastereofacial selectivity? pp 7719–7726

Maria C. Aversa, Anna Barattucci, Paola Bonaccorsi,\* Cristina Faggi, Eszter Gacs-Baitz, Assunta Marrocchi, Lucio Minuti\* and Aldo Taticchi



### Selective synthesis of 14 $\beta$ -amino taxanes pp 7727–7745

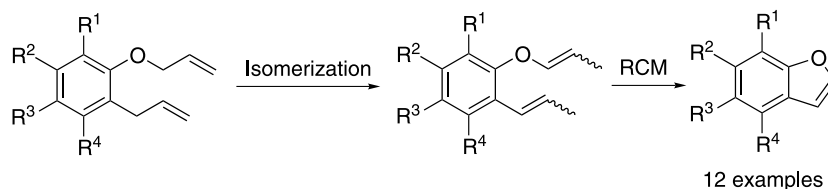
Arturo Battaglia,\* Eleonora Baldelli,\* Ezio Bombardelli, Giacomo Carezzi, Gabriele Fontana, Maria Luisa Gelmi, Andrea Guerrini and Donato Pocar



**An isomerization-ring-closing metathesis strategy for the synthesis of substituted benzofurans**

pp 7746–7755

Willem A. L. van Otterlo,\* Garreth L. Morgans, Lee G. Madeley, Samuel Kuzvidza, Simon S. Moleele, Natalie Thornton and Charles B. de Koning

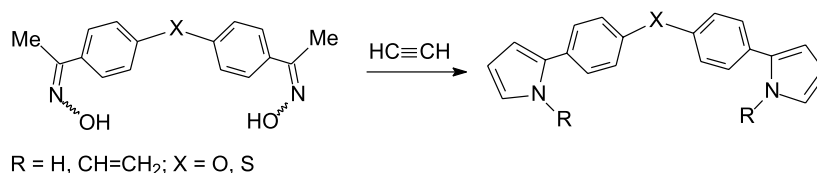


Twelve substituted benzofurans were synthesized from their corresponding substituted 1-allyl-2-allyloxybenzenes using ruthenium-mediated *C*- and *O*-allyl isomerization followed by ring-closing metathesis.

**Synthesis and electrochemical characterization of dipyrroles separated by diphenyleneoxide and diphenylenesulfide spacers via the Trofimov reaction**

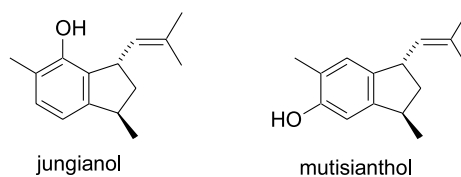
pp 7756–7762

Alexander M. Vasil'tsov, Elena Yu. Schmidt, Al'bina I. Mikhaleva,\* Nadezhda V. Zorina, Alexey B. Zaitsev, Olga V. Petrova, Leonid B. Krivdin, Konstantin B. Petrushenko, Igor' A. Ushakov, Cristina Pozo-Gonzalo, José A. Pomposo and Hans-Jürgen Grande

**Calculated NMR as a tool for structural elucidation of jungianol and mutisianthol**

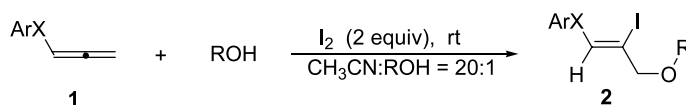
pp 7763–7767

Gil V. J. da Silva\* and Álvaro Cunha Neto

**Stereoselective *Z*-iodoalkoxylation of 1,2-allenyl sulfides or selenides**

pp 7768–7773

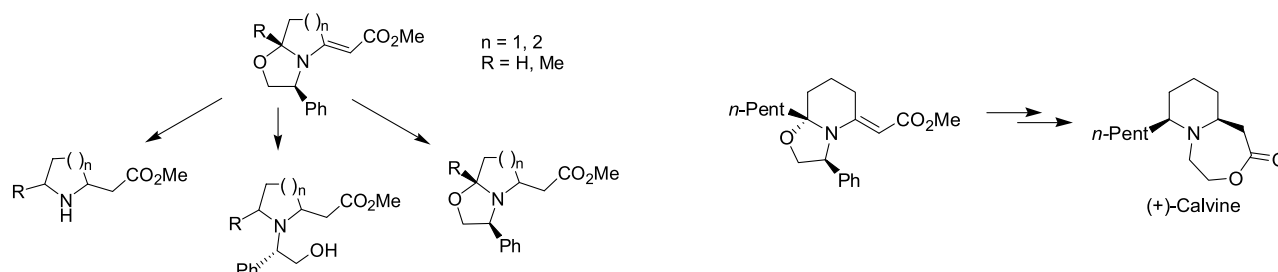
Chunling Fu, Guofei Chen, Xiaoyi Liu and Shengming Ma\*



**Stereocontrolled reduction of chiral pyrrolidine and piperidine  $\beta$ -enamino esters: formal enantioselective synthesis of (+)-calvine**

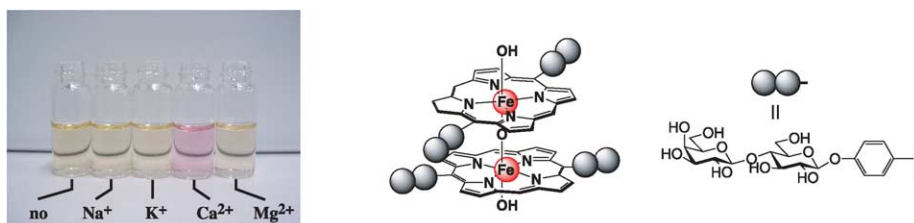
pp 7774–7782

Sandrine Calvet-Vitale, Corinne Vanucci-Bacqué, Marie-Claude Fargeau-Bellassoued and Gérard Lhommet\*


**Colorimetric calcium-response of  $\beta$ -lactosylated  $\mu$ -oxo-bis-[5,15-*meso*-diphenylporphyrinatoiron(III)]**

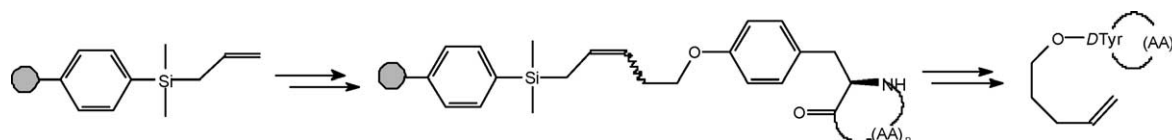
pp 7783–7788

Teruaki Hasegawa, Munenori Numata, Masayoshi Asai, Masayuki Takeuchi and Seiji Shinkai\*


**On-resin cyclization of a head-to-tail cyclopeptide using an allyldimethylsilyl polystyrene resin pre-loaded by metathesis**

pp 7789–7795

Mario Gonçalves, Karine Estieu-Gionnet, Georges Lain, Mireille Bayle, Natacha Betz and Gérard Délérís\*

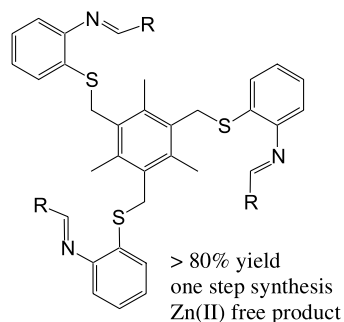


A functionalized anti-angiogenic cyclo-peptide was synthesized under partially protected or deprotected form on an allyldimethylsilyl polystyrene support loaded by metathesis with a conveniently functionalized D-Tyrosine amino-acid.

**Zinc templated synthesis—a route to get metal ion free tripodal ligands and lariat coronands, containing Schiff bases**

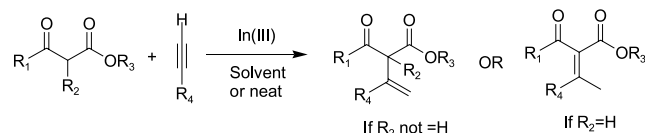
pp 7796–7806

Narinder Singh, Maninder Singh Hundal, Geeta Hundal\* and Martin Martinez-Ripoll



**Indium (III) mediated Markovnikov addition of malonates and β-ketoesters to terminal alkynes and the formation of Knoevenagel condensation products** pp 7807–7813

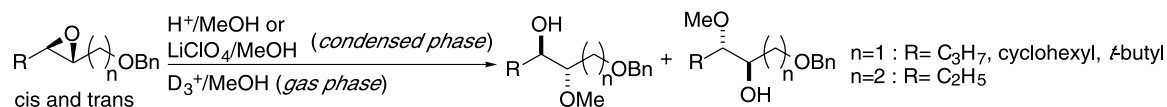
Ji Zhang,\* Peter G. Blazecka, Paul Angell, Mark Lovdahl and Timothy T. Curran

**Regiochemical control of the ring opening of 1,2-epoxides by means of chelating processes.**

pp 7814–7823

**Part 18: Regioselectivity of the opening reactions with MeOH of 1-(benzyloxy)-2,3- and -3,4-epoxyalkanes under condensed and gas phase operating conditions**

Paolo Crotti,\* Gabriele Renzi,\* Graziella Roselli, Valeria Di Bussolo, Laura Lucarelli and Maria Rosaria Romano

**OTHER CONTENTS**Contributors to this issue  
Instructions to contributorsp I  
pp III–VI

\*Corresponding author

📄<sup>+</sup> Supplementary data available via ScienceDirect

This journal is part of **ContentsDirect**, the *free* alerting service which sends tables of contents by e-mail for Elsevier books and journals. You can register for **ContentsDirect** online at: <http://contentsdirect.elsevier.com>

Indexed/Abstracted in: AGRICOLA, Beilstein, BIOSIS Previews, CAB Abstracts, Chemical Abstracts, Chemical Engineering and Biotechnology Abstracts, Current Biotechnology Abstracts, Current Contents: Life Sciences, Current Contents: Physical, Chemical and Earth Sciences, Current Contents Search, Derwent Drug File, Ei Compendex, EMBASE/Excerpta Medica, Medline, PASCAL, Research Alert, Science Citation Index, SciSearch



ELSEVIER

ISSN 0040-4020



Tetrahedron report number 727

# The Nazarov cyclization in organic synthesis. Recent advances

Alison J. Frontier<sup>a,\*</sup> and Christina Collison<sup>b</sup><sup>a</sup>*Department of Chemistry, University of Rochester, Rochester, NY 14627, USA*<sup>b</sup>*Department of Chemistry, Rochester Institute of Technology, Rochester, NY 14623, USA*

Received 10 February 2005

Available online 23 June 2005

## Contents

1. Introduction: synthetic scope and limitations of the Nazarov cyclization . . . . .	7578
2. Factors influencing reactivity . . . . .	7578
2.1. Steric influence of $\alpha$ -substituents . . . . .	7578
2.2. Stereoelectronic influence of $\alpha$ -substituents . . . . .	7579
2.2.1. $\alpha$ -Electron donating substituents . . . . .	7579
2.2.2. $\alpha$ -Electron withdrawing substituents . . . . .	7579
2.3. Substitution at the $\beta$ -position . . . . .	7581
2.3.1. Silicon-directed Nazarov cyclization . . . . .	7581
2.3.2. $\beta$ -sp-Hybridized precursors . . . . .	7581
2.3.3. $\beta$ -Substituents at the internal position . . . . .	7582
2.3.4. Electron-donating $\beta$ -substituents: retro-Nazarov cyclization . . . . .	7583
2.4. Heteroatom substitution on the central carbon of the pentadienyl cation . . . . .	7584
3. Control of torquoselectivity in conrotatory cyclization . . . . .	7584
3.1. Diastereoselective cyclization induced by stereocenters in the substrate . . . . .	7584
3.1.1. $\beta$ -Silyl divinyl ketones . . . . .	7584
3.1.2. Heterocyclic divinyl ketones . . . . .	7585
3.1.3. Allenyl vinyl ketones . . . . .	7586
3.2. Transfer of chirality during torquoselective cyclization . . . . .	7587
3.2.1. Silicon as a traceless auxiliary . . . . .	7587
3.2.2. Axial to tetrahedral chirality transfer . . . . .	7588
3.2.3. Traceless auxiliaries in allenyl ether cyclopentannulations . . . . .	7588
3.2.4. Asymmetric cyclization with conventional chiral auxiliaries . . . . .	7589
3.3. Enantioselective cyclization induced by external chirality: Lewis acids . . . . .	7591
4. Interrupted Nazarov cyclization pathways . . . . .	7591
4.1. Trapping of the oxyallyl cation intermediate with alkenes and arenes . . . . .	7592
4.2. [4+3] Cycloaddition . . . . .	7594
4.3. Reductive trapping . . . . .	7595
4.4. Intramolecular trapping with oxygen functionality . . . . .	7595
4.5. Summary . . . . .	7596
5. Synthetic applications . . . . .	7596
5.1. ( $\pm$ )-Trichodiene . . . . .	7596
5.2. Nazarov cyclizations initiated by acid-catalyzed dehydration of a tertiary alcohol . . . . .	7597
5.2.1. ( $\pm$ )-Xanthocidin . . . . .	7597

**Keywords:** Nazarov cyclization; Cyclopentenone; Stereocenter.

\* Corresponding author. Tel.: +1 585 275 2568; fax: +1 585 276 0205; e-mail: [frontier@chem.rochester.edu](mailto:frontier@chem.rochester.edu)

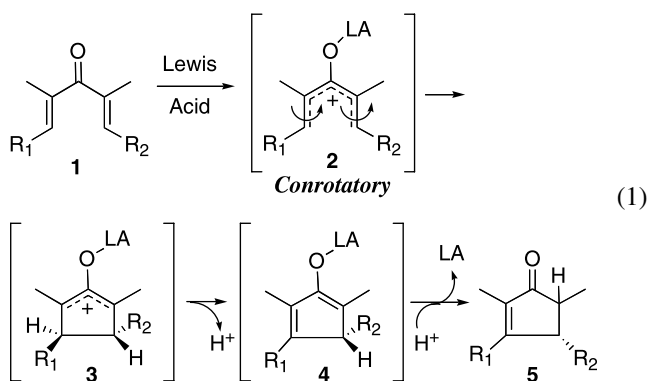


5.2.2.	15-Deoxy-12-hydroxy-10-(trifluoromethyl)- $\Delta^7$ -PGA <sub>1</sub> methyl ester	7597
5.3.	Nazarov cyclizations of alkoxyallenyl vinyl ketones	7598
5.3.1.	$\Delta^7$ -10-Chloro-15-deoxy-PGA <sub>1</sub> ethyl ester	7598
5.3.2.	Roseophilin	7598
5.3.3.	Hydroazulene portion of guanacastepene A	7598
5.4.	Cephalotaxine (CET)	7599
5.5.	Cucumin H	7599
6.	Catalysis of Nazarov cyclization	7600
6.1.	Early work	7600
6.2.	Catalysis with polarized substrates	7601
6.3.	Asymmetric catalysis	7602
7.	Conclusion	7603
	Acknowledgements	7604
	References and notes	7604

## 1. Introduction: synthetic scope and limitations of the Nazarov cyclization

Electrocyclic reactions are powerful synthetic transformations with the ability to create new carbon–carbon bonds stereospecifically by simple orbital reorganization. The subject of this review is a  $4\pi$ -electron process known as the Nazarov cyclization,<sup>1</sup> involving the conversion of divinyl ketones **1** to cyclopentenones **5** by activation with a Lewis acid (Eq. 1).<sup>2</sup> The individual steps involved in the transformation are thought to proceed as follows: a divinyl ketone (**1**) complexes to the Lewis acid to give a pentadienyl cation (**2**); cyclization gives an oxyallyl cation (**3**); elimination of a proton gives a Lewis-acid bound enolate (**4**); and finally, protonation of the enolate gives a cyclopentenone product (**5**).

Importantly, cyclization of pentadienyl cation **2** must proceed with conservation of orbital symmetry, dictating conrotatory ring closure to give a product with an *anti* relationship between R<sub>1</sub> and R<sub>2</sub> (see **3**, Eq. 1). Since disrotatory closure is electronically forbidden, stereospecificity is ensured for the bond formation.<sup>3</sup> Thus, the Nazarov cyclization has the potential to transform an achiral molecule into a single stereoisomeric product. Furthermore, the diastereoselectivity of the reaction can be influenced by stereocenters in the substrate ('torquoselectivity').<sup>4</sup>



Despite this impressive profile, the Nazarov cyclization process as depicted above has serious reactivity and selectivity problems that have historically compromised synthetic utility. Specifically, (1) strong Lewis acids are

often necessary to promote cyclization; (2) multiple equivalents of promoter are required; (3) elimination of the proton is not regioselective (see **3**→**4**); (4) elimination of the proton leads to loss of a stereocenter (see **4**); (5) protonation of the enolate is not stereoselective (see **4**→**5**). Some of these issues were addressed by Denmark's silicon-directed Nazarov cyclization protocol.<sup>5</sup> This review will discuss this and other solutions to the problems just outlined, summarize the current level of mechanistic understanding as demonstrated by experiment, and present recent applications of the Nazarov cyclization to natural product synthesis. Asymmetric Nazarov cyclization strategies will also be discussed. The primary focus will be Nazarov reaction chemistry that has been developed since 1994, when the last comprehensive review appeared.<sup>2a</sup>

## 2. Factors influencing reactivity

The reactivity of divinyl ketones in Lewis acid-promoted Nazarov cyclization is affected by the Lewis acid promoter, but certain characteristics of the substrate also influence reaction behavior. Among these variables are the conformation of the pentadienyl cation intermediate, and both the position and nature of substituents on the substrate.

### 2.1. Steric influence of $\alpha$ -substituents

It has been widely documented that  $\alpha$ -substitution on the divinyl ketone improves cyclization efficiency.<sup>6–10</sup> Divinyl ketones with this substitution pattern are probably more reactive due to an increased population of with *s-trans* enone conformers (Fig. 1), which have the most favorable orientation for cyclization. The  $\alpha$ -alkyl substituents experience unfavorable non-bonded interactions in the *s-cis* conformation, promoting bond rotation to the reactive

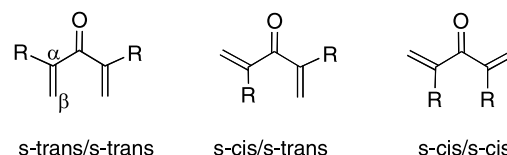


Figure 1. Conformers of divinyl ketones.

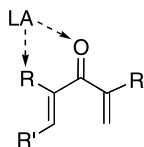


Figure 2. Two-point binding.

*s-trans* conformer. Conversely, when hydrogen occupies the  $\alpha$ -position, the *s-cis* conformation is preferred and cyclization is disfavored.

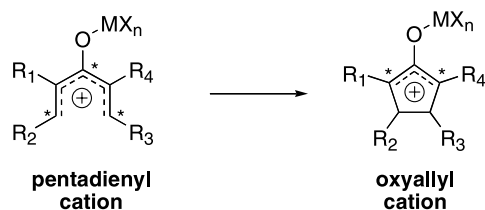
Lewis acids with the ability to bind both the carbonyl oxygen and a functional group at the  $\alpha$ -position of Nazarov substrates can also enforce the *s-trans* conformation, encouraging cyclization (Fig. 2).<sup>11–13</sup>

## 2.2. Stereoelectronic influence of $\alpha$ -substituents

The stereoelectronic influence of divinyl ketone  $\alpha$ -substituents on Nazarov cyclization efficiency has been studied extensively in recent years. Significant progress has been made in developing an understanding of substituent effects, but some of the experimental findings are not yet fully understood. For another, more detailed critical analysis of substituent effects impacting Nazarov cyclization, the reader is referred to the recent Chemtracts article by Harmata.<sup>14</sup>

**2.2.1.  $\alpha$ -Electron donating substituents.** In Denmark's pioneering study of substituent effects in the Nazarov cyclization, a set of guiding principles was proposed to describe the stereoelectronic influence of  $\alpha$ - and  $\beta$ -substituents on reactivity.<sup>6</sup> Specifically, it was postulated that cation stabilizing substituents at the  $\beta$ -positions (i.e.  $R_2$  and  $R_3$ , Scheme 1) would stabilize the pentadienyl cation, raising the activation barrier for cyclization. Conversely, cation-stabilizing substituents at the  $\alpha$ -positions ( $R_1$  and  $R_4$ , Scheme 1) would stabilize the oxyallyl cation product rather than the pentadienyl cation, lowering the activation barrier for cyclization. Experimental findings lent convincing support to this model.

The accelerating influence of an  $\alpha$ -electron-donating substituent on the cyclization reaction has been well documented, with selected examples presented in Table 1. Cyclizations studies by Tius and Kocienski revealed enhanced reactivity in substrates with  $\alpha$ -alkoxy substituents (Table 1, entries 1 and 2) Since these early findings the Tius group, in particular, has developed synthetically valuable cyclopentannulation methodology based on  $\alpha$ -oxygen substituted pentadienyl cation precursors.<sup>10</sup> Cha later reported



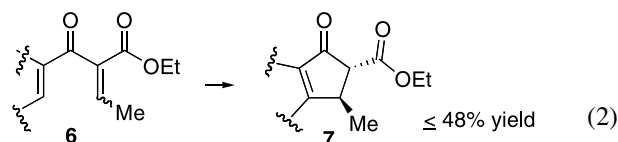
Scheme 1. Denmark: substituent effects on cation stabilization.

the cyclization of a relatively complex substrate bearing an  $\alpha$ -alkoxy substituent (entry 3), and Occhiato and Prandi found that dihydropyran derivatives undergo efficient cyclization under unusually mild acidic conditions via an oxyallyl cation intermediate (entry 4).

Recent studies of  $\alpha$ -oxygen-substituted substrates have led to a very interesting finding: while substrates with  $\alpha$ -carbon substitution have typically required stoichiometric amounts of strong Lewis acids to promote cyclization,<sup>15</sup> substrates with oxygen substitution at the  $\alpha$ -position were reactive enough to undergo rapid cyclization with mild Lewis acids as catalysts (entries 5–8). These examples are discussed in detail in Section 6.

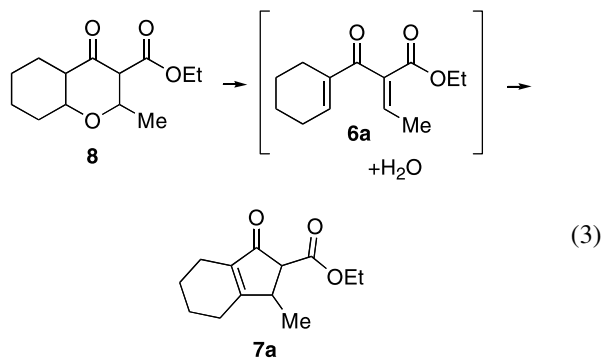
Why are substrates with  $\alpha$ -oxygen substitution so reactive? The electron-donating substituent is thought to increase electron density on the terminal carbon of the pentadienyl cation, lowering the activation barrier to cyclization. After cyclization, the heteroatom is able to stabilize the oxyallyl cation intermediate. Finally, the heteroatom effectively localizes the positive charge at one  $\alpha$ -carbon, which leads to highly regioselective elimination (consider Scheme 1;  $R_1$  = alkoxy).

**2.2.2.  $\alpha$ -Electron withdrawing substituents.** These observations suggested that compounds of this type were highly reactive and prone to polymerization under Lewis acidic conditions. However, rather than the usual mixture of regioisomers, cyclopentenone **7** was the only enone observed. Regan and Andrews reported that stereoselectivity of the protonation step (see **4**  $\rightarrow$  **5**, Eq. 1) was also excellent, giving the *trans* isomer (**7**) as shown in (Eq. 2). The high stereoselectivity of protonation is thought to arise from facile equilibration of the  $\beta$ -ketoester stereocenter under the reaction conditions, which would provide the more stable *trans* product.



Reaction Conditions: a)  $\text{Me}_3\text{SiI}$  (2 equiv.),  $\text{CCl}_4$ , rt, (reference 7); or b)  $\text{Me}_3\text{SiOTf}$  (5 equiv.)  $\text{CH}_2\text{Cl}_2$ , rt (reference 8).

Tetrahydropyrans like **8** are thought to undergo a dehydration process under the reaction conditions, generating divinyl ketones **6** in situ (Eq. 3).<sup>8,22</sup> This method gives consistently better yields of cyclopentenones **7** relative to reactions initiated with divinyl ketones and using the same Lewis acid promoters (cf. Eq. 2). Both Regan and Takeda, using related but slightly different Lewis acidic conditions, have reported conversion of **8** to **7a**, as shown in (Eq. 3).<sup>23</sup> Although no explanation is offered for the increased efficiency observed in cyclization via tetrahydropyran **8**, the geometry of the alkylidene  $\beta$ -ketoester generated in situ may play a role (see Section 2.3.3).



Reaction Conditions: a)  $\text{Me}_3\text{SiOTf}$  (5 equiv.)  $\text{CH}_2\text{Cl}_2$ , rt (reference 8) or b)  $\text{Me}_3\text{SiCl-NaI}$  (10 equiv.), DMF,  $120^\circ\text{C}$  (reference 22). 77% yield reported for both sets of reaction conditions.<sup>23</sup>

Recently, Flynn and co-workers have reported highly efficient Nazarov cyclizations of alkylidene  $\beta$ -ketoesters of type **6** (Eq. 4).<sup>24</sup> These cyclizations were promoted by protic acid

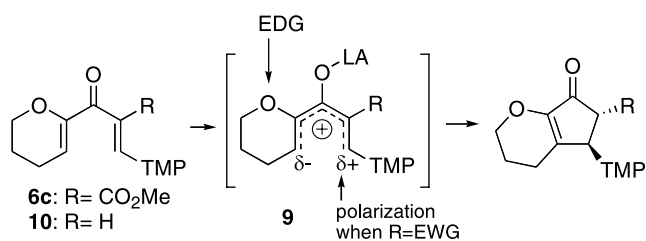
and, in a few cases, copper triflate. Consistent with the results of Regan and Andrews, only the *trans* product was isolated, and the elimination step was highly regioselective. The group uses a new cross-coupling method to prepare substrates **6b**, which initially provides *Z* rather than *E* alkylidene  $\beta$ -ketoesters. *E/Z* isomerization occurs gradually over time, but the predominance of *Z* isomer at the outset may improve reaction efficiency (Section 2.3.3) and help to explain the contrast between these results and those shown in (Eq. 2).



Reaction Conditions:  $\text{MeSO}_3\text{H}$  (1.1 equiv.) in  $\text{CH}_2\text{Cl}_2$ ,  $18^\circ\text{C}$ , 24 h, 88% yield.

**Table 1.** Cyclizations of dienones with electron-donating  $\alpha$ -substituents

Entry	Substrate	Reaction conditions	Product	Yield	Reference; year
1		HCl/MeOH 48 h		59%	16; 1994
2		Combine ( $-78^\circ\text{C}$ ); then 5% HCl/ MeOH ( $0^\circ\text{C}$ )		91%	17; 1994
3		$\text{Et}_2\text{AlCl}$ (4.8 equiv) $\text{CH}_2\text{Cl}_2$ , $-78^\circ\text{C}$ to rt		63%	18; 2000
4		Amberlyst 15, then TFA		~70%	19; 2003
5		2 mol% $\text{Cu}(\text{OTf})_2$ $\text{Cl}(\text{CH}_2)_2\text{Cl}$ , rt		>99%	20; 2003
6		10 mol% $\text{AlCl}_3$ , $\text{CH}_2\text{Cl}_2$ , rt		88%	11a; 2003
7		10 mol% $\text{PdCl}_2(\text{MeCN})_2$ wet acetone, rt		91%	21; 2003
8		20 mol% $\text{Pd}(\text{OAc})_2$ DMSO, $\text{O}_2$ , $80^\circ\text{C}$		53%	21; 2003

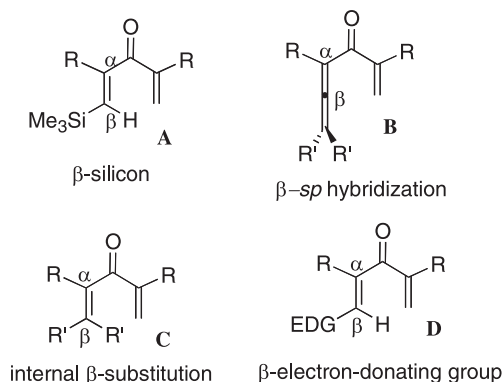


**Scheme 2.** Polarized divinyl ketones. TMP = 2,4,6-trimethoxyphenyl. Reaction conditions: 2 mol% Cu(OTf)<sub>2</sub>, Cl(CH<sub>2</sub>)<sub>2</sub>Cl, rt; < 5 min (**6c**) versus 20 min. (**10**).

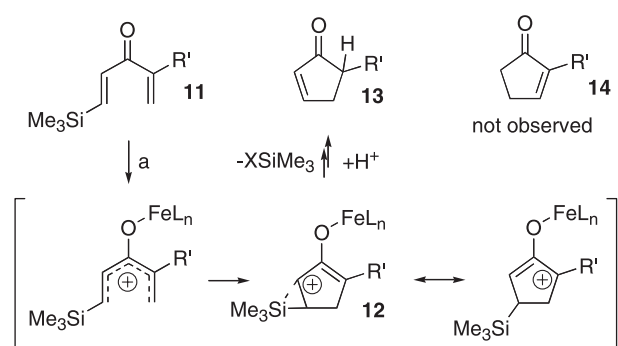
Finally, substrates **6c**, bearing both electron-donating and electron-withdrawing  $\alpha$ -substituents have been studied by Frontier and co-workers (Scheme 2). Initial experiments suggested that this substituent combination is able to polarize the pentadienyl cation (see **9**) and increase its reactivity, since cyclization proceeds under mild conditions. This was an early example of a Nazarov cyclization catalytic in Lewis acid. Also, replacement of the  $\alpha$ -withdrawing substituent with a hydrogen (e.g., **10**) reduces cyclization efficiency in some substrates. However, the electron-withdrawing group does not consistently improve cyclization rates, and its role has become more ambiguous with continued study.<sup>25</sup> Given that Denmark's model (Scheme 1) predicts that an electron-withdrawing group at the  $\alpha$ -position of the pentadienyl cation will reduce reaction rate,<sup>6,14</sup> a more extensive examination of  $\alpha$ -withdrawing substituent effects is necessary (and ongoing).

### 2.3. Substitution at the $\beta$ -position

Several research groups have discovered important trends in reactivity depending upon the nature of substitution at the  $\beta$ -position of the divinyl ketone. In general,  $\beta$ -substitution slows reaction rate,<sup>6</sup> but the type, geometry, steric and stereoelectronic impact of substitution pattern at the  $\beta$ -position are all factors that affect reactivity. Four different types of  $\beta$ -substitution will be discussed in this section:  $\beta$ -silicon substituted divinyl ketones **A**,  $\beta$ -sp hybridized substrates **B**, substrates with internal  $\beta$ -substitution (**C**) and substrates bearing  $\beta$ -electron-withdrawing groups (**D**).



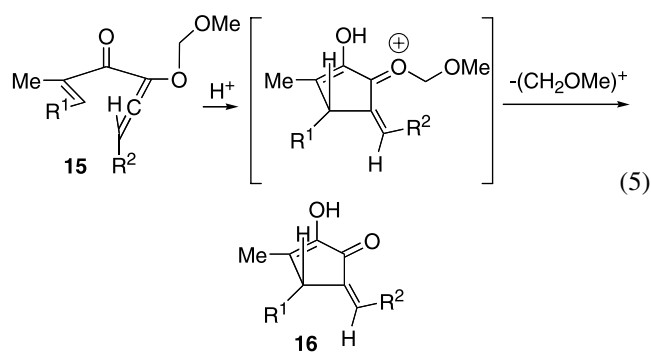
**2.3.1. Silicon-directed Nazarov cyclization.** Denmark and co-workers designed  $\beta$ -silicon substituted divinyl ketones **11** in order to study the ability of silicon to stabilize and control the reactivity of the oxyallyl cation intermediate



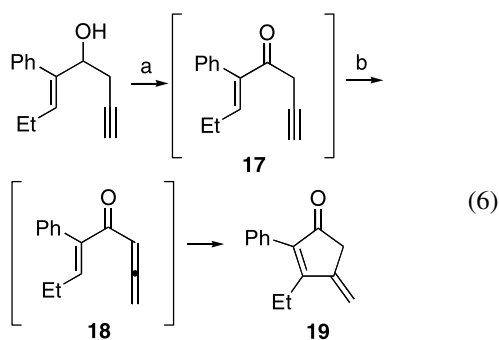
**Scheme 3.** Silicon-directed Nazarov cyclization. Reaction conditions: (a) FeCl<sub>3</sub> (1.05 equiv), CH<sub>2</sub>Cl<sub>2</sub>, -30 °C to rt.

(Scheme 3).<sup>5</sup> Through the  $\beta$ -cation-stabilizing effect of silicon,<sup>26</sup> it is possible to concentrate the positive charge density at one of the allyl cation termini (see **12**), and effect regioselective elimination using FeCl<sub>3</sub> as promoter. The presence of the stabilizing silicon has two practical advantages: side reactions that compromise the efficiency of the cyclization are suppressed and the regioselective elimination is directed such that the thermodynamically less stable enone products (i.e., **13** rather than **14**) are formed exclusively. For an extensive discussion of the scope and utility of this strategy, see Denmark's 1994 review.<sup>2</sup>

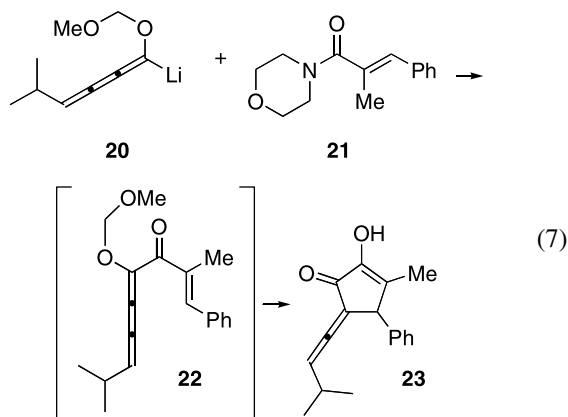
**2.3.2.  $\beta$ -sp-Hybridized precursors.** Allenyl and cumulenyl derivatives display excellent reactivity in Nazarov-type cyclizations. The Tius group has demonstrated that cyclization of oxyallenones **15** is a general and efficient method for the preparation of cyclopentenones **16** (Eq. 5).<sup>10</sup> This version of the reaction has served as the cornerstone of a number of strategies targeting complex natural products (see Section 5).



Hashmi and co-workers have found that upon treatment with silica gel,  $\beta$ -alkynyl ketone **17** cyclizes to provide conjugated dienone **19**, presumably via the allenyl ketone intermediate **18** (Eq. 6).<sup>27</sup> Finally, the Tius group recently reported the first cyclization of cumulenones like **22**, which was generated in situ from the cumulenyl lithium **20** and enamide **21** (Eq. 7).<sup>28</sup> Substrates with aromatic substitution on the enamide undergo cyclization under the mildly acidic conditions of aqueous workup, to give allenylketones like **23**.



Reaction Conditions: a) Dess-Martin periodinane, b) silica gel, 54% yield.

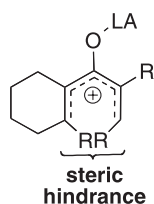


Reaction Conditions:  $-78^{\circ}\text{C}$  to  $-40^{\circ}\text{C}$ ; then aqueous  $\text{KH}_2\text{PO}_4$ , 59% yield.

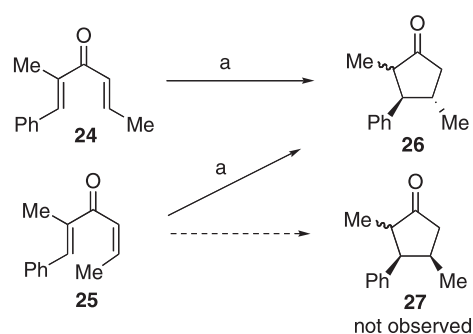
The enhanced reactivity observed in allenyl and cumulenyl substrates is thought to derive from two unique features of the corresponding cationic intermediates. First, steric interactions at the  $\beta$ -position of these substrates are at a minimum, which is expected to increase the population of species in the reactive *s-trans* geometry (see Fig. 1). Thus, the facile approach of the allenic  $\text{sp}$  and vinyl  $\text{sp}^2$  carbon translates to a lower activation barrier for C–C bond formation. Second, allenic strain may be alleviated in the transition state upon formation of the allyl cation, providing a driving force for the reaction in these substrates.<sup>29,30</sup>

**2.3.3.  $\beta$ -Substituents at the internal position.** Substrates with internal  $\beta$ -substitution suffer steric hindrance when the cation adopts the conformation necessary for electrocyclic cyclization (Fig. 3).

The degree to which this hindrance affects cyclization has not been studied extensively, but experiments show that



**Figure 3.** Nonbonded interactions at the  $\beta$ -position of the reactive pentadienyl cation.

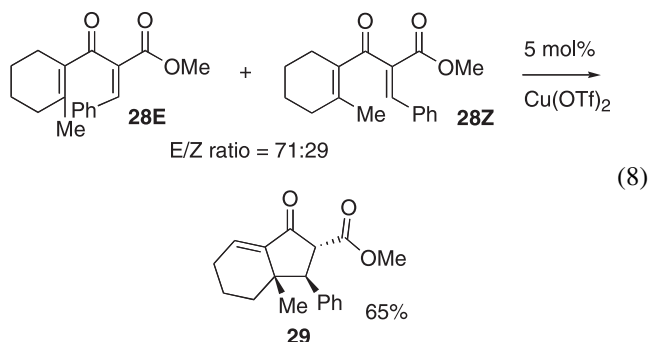


**Scheme 4.** Olefin isomerization under Lewis acidic conditions. Reaction conditions: a)  $\text{BF}_3\text{-OEt}_2$  (1.1 equiv),  $\text{Et}_3\text{SiH}$  (10 equiv).

compounds containing tetrasubstituted alkenes cyclize more slowly than the analogous trisubstituted alkenes.<sup>31</sup> Other experiments suggest that internal  $\beta$ -substituents in disubstituted enones and trisubstituted alkylidene  $\beta$ -ketoesters engage in an isomerization pathway that is strongly favored over the cyclization pathway. These processes are described below.

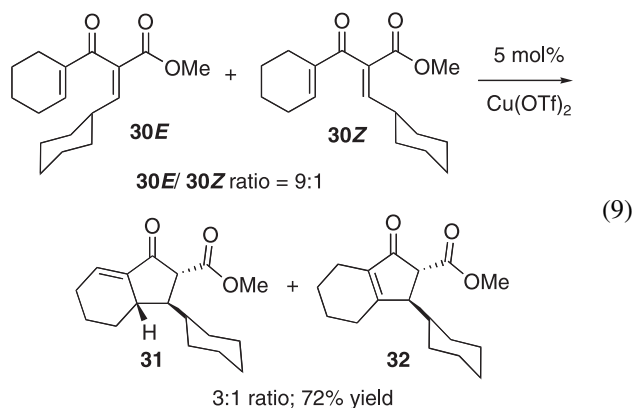
West found that Nazarov cyclization of both *trans*- and *cis*-disubstituted enones **24** and **25** gives the same diastereomeric product **26** (Scheme 4).<sup>32</sup> The stereochemistry of **26** corresponds to conrotatory cyclization of *trans* isomer **24**, whereas cyclopentanone diastereomer (**27**), corresponding to cyclization of *cis* dienone **25**, was not observed. This indicates that under the reaction conditions, the *cis*  $\beta$ -methyl enone **25** undergoes isomerization prior to cyclization. Similar isomerization behavior has been noted by Denmark in the cyclization of *cis*- $\beta$ -silyl enones.<sup>33</sup>

Recent experiments indicate that trisubstituted alkylidene  $\beta$ -ketoesters like **28** also exhibit complex behavior during cyclization.<sup>34</sup> When a 71:29 mixture of *E* and *Z* olefins underwent cyclization, only diastereomer **29** was isolated, rather than the two isomers expected from conrotatory cyclization of the two divinyl ketones (Eq. 8). This suggests that the isomer with *Z* geometry cyclizes to give product, while the isomer with *E* geometry undergoes isomerization prior to cyclization. This theory was confirmed when pure samples of the two isomers were subjected to the cyclization conditions: **28E** took more than 24 h to cyclize, while cyclization of **28Z** was complete in an hour. Both reactions give the same diastereomeric product (**29**).



In **28E**, the steric hindrance between the methyl group and the  $\beta$ -phenyl at the internal position would be extremely disruptive to cyclization (Fig. 3). However, the same

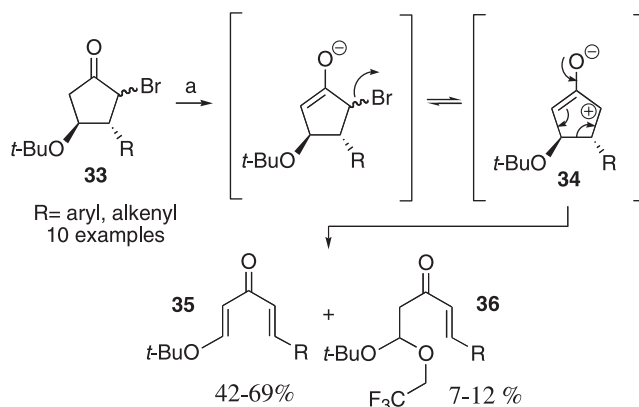
isomerization behavior was observed during cyclization of **30**, a  $\beta$ -unsubstituted cyclohexene (Eq. 9). The regioselectivity of elimination is compromised (see **32**), but note that even when steric hindrance on the cyclohexene is reduced, the reaction still affords only one diastereomer: cyclic enone **31**. Again, this is the isomer expected from conrotatory cyclization of **30Z**, the *minor* component of the reaction mixture.



In the examples discussed above, an internal  $\beta$ -substituent hinders cyclization to such an extent that no reaction occurs. Instead, olefin isomerization occurs under the reaction conditions, and cyclization of an intermediate with  $\beta$ -substituent *exo* occurs exclusively. This behavior is consistent with the theoretical predictions of de Lera and co-workers.<sup>35</sup> It is possible that isomerization behavior like this often precedes cyclization, but is not observed because a diagnostic stereocenter is lost in the elimination step (for an example, see product **32**, Eq. 9). Therefore, it is not surprising that the documented examples both have unusual qualities that allow detection of the isomerization: in Scheme 4, the reaction is conducted in the reductive regime (described in detail in Section 4) avoiding the elimination step altogether, and in (Eq. 8), quaternary center formation directs elimination *exo* to the new cyclopentanone ring, preserving the stereocenter created during conrotatory cyclization.

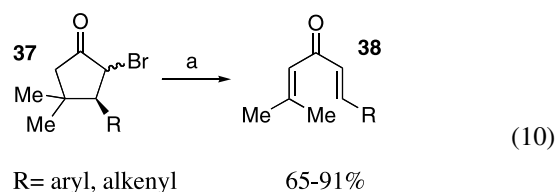
**2.3.4. Electron-donating  $\beta$ -substituents: retro-Nazarov cyclization.** According to Denmark's model (Scheme 1),  $\beta$ -electron-donating groups are expected to stabilize the pentadienyl cation precursor, discouraging cyclization. In 2002, Harmata and Lee reported that  $\beta$ -alkoxy substituents not only stabilize the pentadienyl cation species, but also facilitate efficient reversal of the process (Scheme 5).<sup>36</sup> This transformation, termed the 'retro-Nazarov' cyclization, involves solvolytic formation of an oxyallyl cation **34** from  $\alpha$ -bromocyclopentanone **33**, which undergoes ring-opening to give the divinyl ketone **35** in good yield. A small amount of conjugate addition product **36** was also isolated in each case. Efficient retro-electrocyclization depended upon the presence of a second pentadienyl cation-stabilizing substituent, such as an aromatic or alkenyl group.

Harmata and Schreiner have continued to study the retro-Nazarov reaction for substrates with various  $\beta$ -electron-donating groups, using density functional theory.<sup>37</sup> They have found that activation energies are slightly lowered by



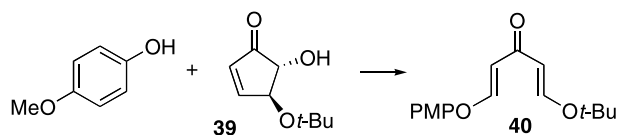
**Scheme 5.** The Retro-Nazarov reaction. Reaction conditions: (a) triethylamine (1.1 equiv), trifluoroethanol, reflux.

$\beta,\beta$ -dialkyl substitution, moderately lowered by  $\beta$ -vinyl substitution, and significantly lowered by  $\beta$ -alkoxy substitution. The data were consistent with the group's earlier experimental findings, and a series of new experiments were carried out in the laboratory to explore cyclization of cyclopentane derivatives with the  $\beta,\beta$ -dialkyl substitution pattern. When the second  $\beta$ -position has aryl or vinyl substitution (see **37**), smooth ring-opening occurs to give divinyl ketones **38** (Eq. 10). These results indicate that the calculations had indeed identified a new reactive substitution pattern, and could serve as a reliable method for predicting relative reactivity in the retro-Nazarov cyclization.



Reaction Conditions: a) triethylamine (1.1 equiv.), trifluoroethanol, reflux. (4 examples).

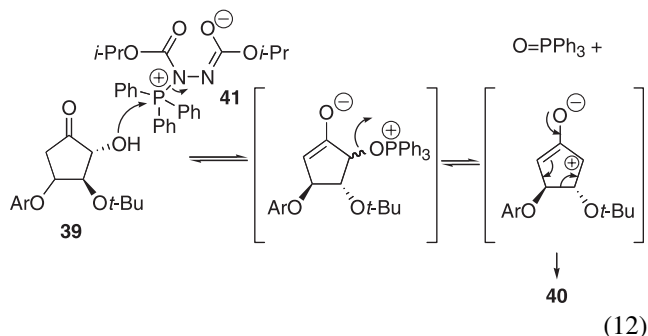
A related case of ring-opening retro-Nazarov reaction was reported by Caddick during his study of compound **39**.<sup>38</sup> In the presence of *p*-methoxyphenol, triphenyl phosphine and diisopropyl azodicarboxylate, **39** was converted to divinyl ketone **40** (Eq. 11). Although the efficiency of the transformation was poor, the example is interesting because it involves a substrate different from those studied by Harmata, and a different reaction pathway for generation of the oxyallyl cation.



Reaction Conditions: THF, PPh<sub>3</sub>, 0 °C, then DIAD, rt, 14%.

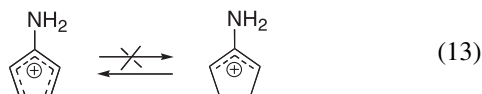
While the Harmata procedure for oxyallyl cation generation involves solvolytic loss of bromine, the mechanism of formation in the Caddick case is not known. The mechanism postulated by the authors begins with conjugate addition of

*p*-methoxyphenol to **39**. Then, the  $\alpha$ -oxygen is activated with phosphonium derivative **41**, and ionization is driven by the formation of triphenylphosphine oxide (Eq. 12).



#### 2.4. Heteroatom substitution on the central carbon of the pentadienyl cation

Nazarov cyclizations typically involve an oxygen heteroatom on the central carbon of the pentadienyl cation. It has been determined by ab initio molecular orbital studies that cyclization of the analogous nitrogen-substituted pentadienyl cation is energetically disfavored (Eq. 13).<sup>39</sup> To be efficient, an ‘imino-Nazarov cyclization’ would require a driving force able to overcome the stabilization provided by the electron-donating amino group on the ring-open cation.



It had been shown that allenyl nucleophiles will react with  $\alpha,\beta$ -unsaturated Weinreb amides and cyclize to form cyclopentanone products in high yields.<sup>17</sup> Extrapolating from these results, Tius’ group explored the reaction of similar allenyl nucleophiles with  $\alpha,\beta$ -unsaturated nitriles in order to generate  $\alpha$ -aminocyclopentanones.<sup>40</sup> The addition of  $\alpha$ -lithio- $\alpha$ -(methoxy)methoxyallene **43** to the  $\alpha$ -methylcinnamionitrile **42** at  $-78^\circ\text{C}$  forms the lithioimine intermediate **44** which cyclizes under the acidic workup conditions (Scheme 6). A saturated aqueous solution of dihydrogen phosphate is the optimal acid, giving the (isolable) product **45**. For isolation, the amine was protected as the acetamide **46** and an isolated overall yield of 73% obtained.

Cyclization of alkoxyallene intermediate **44** culminates in the critical irreversible loss of the methoxymethyl cation. Further studies showed similar success when different  $\alpha,\beta$ -unsaturated nitriles and alkoxy allenes were tested. Moderate yields were obtained in all cases except reactions

using an  $\alpha,\beta$ -unsaturated nitrile with a hydrogen at the  $\alpha$ -carbon. In these cases, no reactions were observed. These transformations, together with the single example reported by Cha (see Section 5.4),<sup>11</sup> are the only reported examples of imino-Nazarov cyclizations known to us.

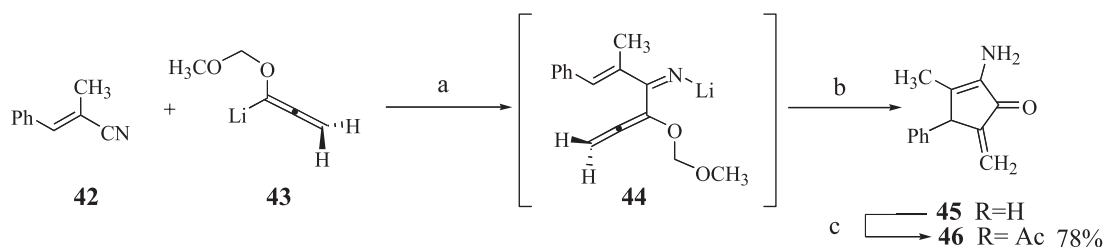
### 3. Control of torquoselectivity in conrotatory cyclization

As shown in Scheme 7, conrotatory cyclization can occur either in a ‘clockwise’ or a ‘counterclockwise’ sense. If the reaction is controlled such that only one direction of conrotation occurs, cyclization is described as torquoselective.<sup>4</sup> It has been found that a remote stereocenter in the molecule can influence the sense of conrotation, to allow cyclization to occur with high diastereoselectivity. Enantiomerically enriched product mixtures are obtained when the remote stereocenter is non-racemic and is lost during the cyclization. In these cases, torquoselective cyclization has allowed transfer of chirality from the original center to a new carbon center. In the corresponding two-step process, auxiliaries have been used to communicate chirality to new cyclopentenone stereocenters in the torquoselective process. Diastereoselective cyclization occurs in the first step, with the auxiliary removed in the second step to provide enantiomerically enriched products. Finally, chiral Lewis acids are able to promote asymmetric cyclization of achiral divinyl ketones, in a torquoselective cyclization influenced by an external source of chirality.

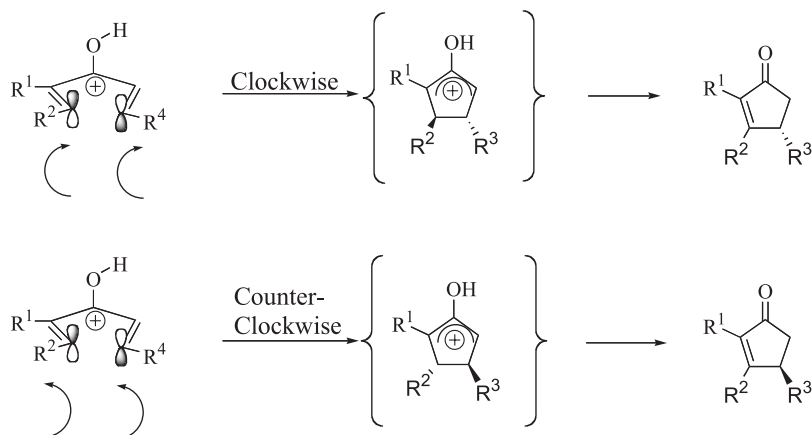
#### 3.1. Diastereoselective cyclization induced by stereocenters in the substrate

A stereocenter in the divinyl ketone will influence the sense of conrotation, leading to torquoselective cyclization. In many cases, bond formation occurs on the face opposite to a ring substituent, due to steric hindrance. The degree of selectivity varies depending on the position of the existing stereocenter relative to the position of bond formation, and on the conformation of bicyclic intermediates during cyclization. Silicon substitution may also exert a stereo-electronic effect, by providing continuous stabilization of the intermediate cation during cyclization.<sup>5</sup>

**3.1.1.  $\beta$ -Silyl divinyl ketones.** Denmark and co-workers have documented diastereoselective cyclization in the silicon-directed Nazarov cyclization.<sup>41,42</sup> Torquoselectivity is good for cyclohexa-fused substrates (Table 2), but poor for the cyclopenta-fused analogs.<sup>41b</sup> As one might expect, the best selectivity is observed when the directing stereocenter was near the  $\beta$ -terminus of the divinyl ketone, and



**Scheme 6.** Reaction conditions: (a) THF,  $-78^\circ\text{C}$ , 1 h; (b) sat. aq.  $(\text{NH}_4)_2\text{HPO}_4$ ,  $-78^\circ\text{C}$  to rt, 30 min; (c)  $\text{Ac}_2\text{O}$ , pyr., cat. DMAP, rt, 18 h; 78%.



**Scheme 7.** The stereochemical effects of torquoselectivity in a general system.

**Table 2.** Torquoselectivity in the silicon-directed Nazarov cyclization

R	R'	Product ratio (a/b)	Yield (%)
Ph	SiMe <sub>3</sub>	94/6	76
<i>t</i> -Bu	SiMe <sub>3</sub>	94/6	63
CH <sub>3</sub>	SiMe <sub>3</sub>	78/22	99
CH <sub>3</sub>	SiPh <sub>2</sub> Me	86/14	83
CH <sub>3</sub>	Si( <i>i</i> -Pr) <sub>3</sub>	90/10	70

larger alkyl groups gave better selectivity. Employing silyl groups with more steric bulk also improves selectivity, but chemical yield was significantly reduced.

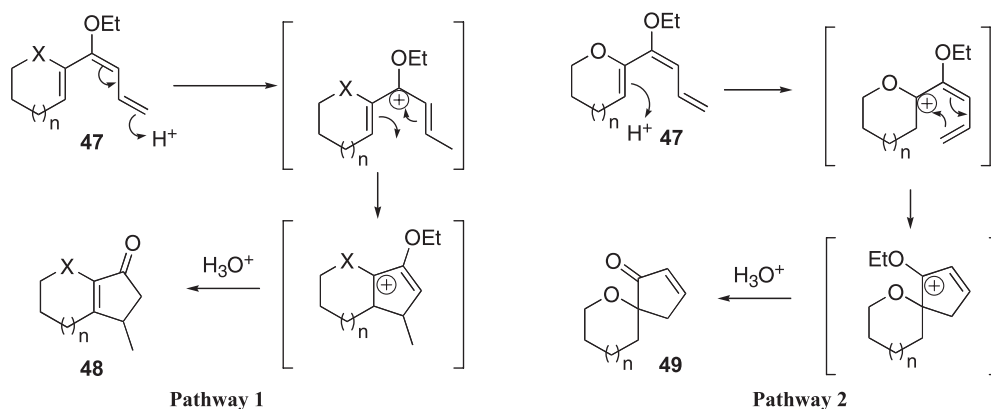
The stereochemical results observed can be explained through a steric argument: orbital overlap can be achieved more easily on the less-hindered face of the cyclohexenyl unit. Therefore, the vinyl group preferentially approaches from the face opposite the allylic substituent on the ring.

**3.1.2. Heterocyclic divinyl ketones.** Torquoselectivity in the Nazarov cyclization of 2-substituted heterocycles of type **47** (Scheme 8) has been examined extensively by

Occhiato and Prandi.<sup>19,43,44</sup> Generation of the pentadienyl cation intermediate was effected by protonation of dienyl ethers with the mild acidic Amberlyst 15 resin to give products **48** (pathway 1, Scheme 8). In cyclizations of oxygen-containing heterocycles, spiro-fused cyclopentenones **49** were also observed as minor reaction products, presumably via the alternative protonation shown in pathway 2.

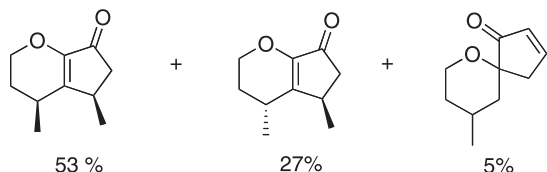
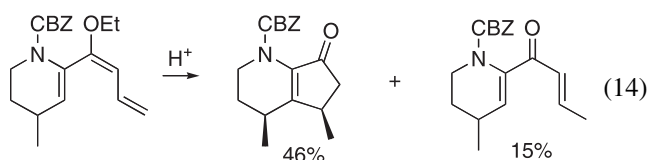
Cyclizations were carried out on a wide range of heterocyclic substrates bearing substituents on nearly every ring carbon. Presented below are selected experimental results that provide an overview of the influence of heterocyclic substituents on conrotatory cyclization. While stereoselectivity trends are clear, chemoselectivity is not consistent from substrate to substrate, so it is important to realize that the cases chosen represent the cyclizations that occur with both the greatest efficiency and the highest diastereoselectivities.

Consistent with the findings of Denmark and co-workers, substitution at the allylic ring position results in bond formation on the opposite face of the ring (Eqs. 14 and 15). When the substituent is large, like phenyl or *t*-butyl, cyclization is inhibited, and yields were low. Torquoselectivity is excellent for dihydropiperidines (Eq. 14), but modest for dihydropyrans (Eq. 15).



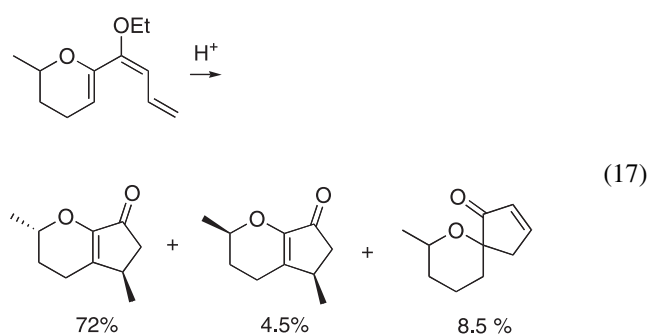
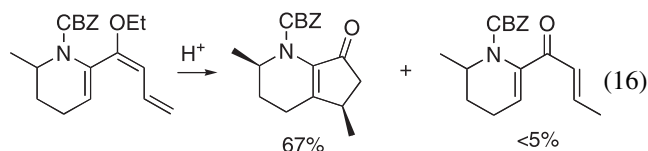
**Scheme 8.** Protonic acid-initiated cyclization of dienyl ethers.





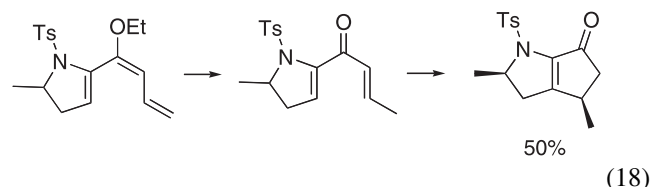
Interestingly, good diastereoselectivity is also observed in cyclizations of six-membered heterocycles with a substituent at the 5-position, although the sense of torquoselectivity is opposite for N versus O heterocycles (Eqs. 16 and 17). The non-bonded interactions caused by an equatorially disposed methyl substituent during cyclization are expected to be minimal, so another argument was needed to explain both the high torquoselectivity and the different stereochemical outcomes observed.

The authors propose that in the dihydropiperidines, allylic strain caused by the N-protecting group leads to axial orientation of the methyl substituent, creating enough steric hindrance to significantly influence stereoselectivity. The dihydropyran stereochemistry was more difficult to rationalize. The stereochemistry observed arises from a transition state in which the dihydropyran adopts a boat-like conformation, and the authors suggest that better orbital overlap for electrocyclization might be achieved through this conformer.

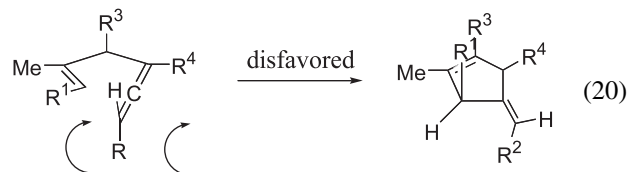
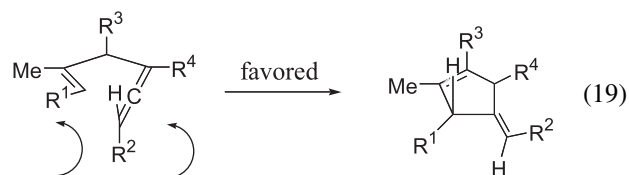


Finally, Amberlyst catalysis is not effective for the cyclization of five-membered azacycles: hydrolysis with Amberlyst and then acid-catalyzed cyclization (neat TFA) was required. However, the reaction is quite

diastereoselective for the product with the methyl groups in a *cis* relationship (Eq. 18). As described above, selectivity is likely due to axial disposition of the ring substituent, directing bond formation to the opposite face of the dihydropyran.



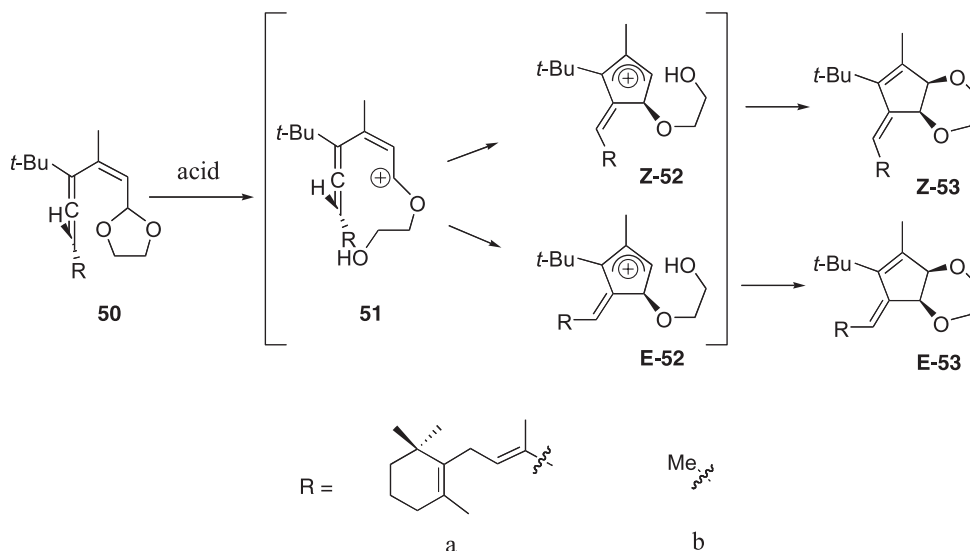
**3.1.3. Allenyl vinyl ketones.** Allenes are of great importance when studying the effects of torquoselectivity during Nazarov cyclizations. A bulky group at  $R^2$  is predicted to facilitate the counterclockwise conrotation (Eq. 19) since this allows the larger  $R^2$  group to rotate away from  $R^1$ . (Eq. 20) illustrates the disfavored clockwise rotation whereby the bulky group rotates toward the ring and  $R^1$ .



De Lera and co-workers have discovered the facile rearrangement of the allene **50** to the dioxane **53** upon treatment with a variety of acids (Scheme 9; see also Section 4.4).<sup>45</sup> This variant of the Nazarov cyclization proceeds via the generation of the carbocation **51**, which cyclizes to form the oxyallyl cationic ring **52**. This intermediate then undergoes intramolecular trapping by the remaining hydroxyl group to give the 1,4-dioxin **53**.

Since there is substitution at either termini of the allenyl moiety in **50**, conrotatory cyclization or torquoselectivity could give rise to either a *Z* or *E* exocyclic olefin. De Lera found that there was a much higher torquoselectivity favoring the *Z* configuration when the acids  $\text{LiBF}_4$ ,  $\text{FeCl}_3 \cdot \text{SiO}_2$ ,  $\text{LiClO}_4$  and  $\text{PdCl}_2(\text{CH}_3\text{CN})_2$ , were employed. He ventured that the true torquoselectivity was indeed forming the *E* isomer but that under standard conditions at room temperature, isomerization to the thermodynamically favored *Z* configuration was occurring (Table 3).

Treatment of the purified *E*-**53a** isomer under standard reaction conditions without an acid present, did not promote isomerization. However, when the reaction was charged with *p*-TsOH, the *E*-**53a** isomer was converted to the *Z*-**53a** isomer. When **50a** was subjected to acidic conditions between  $-60$  and  $-40$  °C,  $^1\text{H}$  NMR showed a significant amount of *E*-**53a** with respect to *Z*-**53a**. As the temperature was slowly increased to 25 °C, equilibration to the *Z*-isomer ensued. De Lera concluded that *Z*-**53a** is thermodynamically



**Scheme 9.** Mechanism of cyclization for acetals **50a–b** under acidic conditions.

more stable than **E-53a** and that isomerization was indeed disguising the initial diastereomeric ratio of the exocyclic alkenes when formed at lower temperatures and before being warmed to the standard 25 °C. DFT calculations suggest that clockwise rotation to give the *E* isomer was preferable so as to avoid steric hindrance between the R group and the C-1 substituent. However, acid-induced equilibration of *E-53a* to favor *Z-53a* is driven by the steric interaction between the bulky *t*-butyl group and the R substituent.

De Lera's success in enhanced torquoselectivity as seen using **50a** is not realized in all systems. It is observed that when R is a smaller alkyl substituent such as a methyl group (**50b**), isomeric ratios are inconclusive (Table 3). Since the methyl group is less bulky, **50b** was not as torquoselective. Subjection of the reaction mixture for a prolonged period to various acidic conditions did not alter the *E* and *Z* isomeric ratios for the product **53b**. Nevertheless, these findings open a new avenue for such cyclizations from allenyl divinyl ketones that could be incorporated into the syntheses of useful compounds. For a

further discussion of torquoselectivity in allenyl systems see Section 3.2.2.

### 3.2. Transfer of chirality during torquoselective cyclization

**3.2.1. Silicon as a traceless auxiliary.** Work by Denmark and co-workers describes the use of silicon as a traceless auxiliary to easily and selectively construct linear tricyclic systems.<sup>33</sup> Starting with a silicon-bearing  $\beta'$ -stereogenic center to induce selectivity, ketone (*S*)-(–)-**54** and (*R*)-(+)-**54** were treated with FeCl<sub>3</sub> in CH<sub>2</sub>Cl<sub>2</sub> at –50 °C (Scheme 10). The torquoselectivity experienced by both (*S*)-(–)-**54** and (*R*)-(+)-**54** to give the allyl cations **56a** and **56b**, respectively, is due to stereoelectronic considerations. The remote silicon group in each case favors a geometry that is conducive to continuous overlap with the allyl cation moiety. As a result, (*S*)-(–)-**54** selectively cyclizes to oxyallyl cation **56a**, which was subsequently acted upon by the halogen to eliminate the silicon group in an anti-*S'*<sub>E</sub> fashion. The resulting tricyclic (–)-**57** was obtained in 72% yield and without loss of enantiomeric excess relative to the

**Table 3.** Acidic conditions for cyclization of **50a–b**

Acetal	Acid	Product	<i>Z/E</i> ratio <sup>a</sup>	<i>Z/E</i> ratio <sup>b</sup>	Yield (%) <sup>c</sup>
<b>50a</b>	<i>p</i> -TsOH <sup>d</sup>	<b>53a</b>	42:58	> 99:1	99
	FeCl <sub>3</sub> ·SiO <sub>2</sub> <sup>e</sup>		> 99:1	96	
	LiBF <sub>4</sub> <sup>f</sup>		66:34	66:34	99
	LiClO <sub>4</sub> <sup>g</sup>		> 99:1	92	
	PdCl <sub>2</sub> (CH <sub>3</sub> CN) <sub>2</sub> <sup>h</sup>		> 99:1	99	
<b>50b</b>	<i>p</i> -TsOH <sup>d</sup>	<b>53b</b>	35:65	25:75	50
	FeCl <sub>3</sub> ·SiO <sub>2</sub> <sup>e</sup>		42:58	50:50	85
	LiBF <sub>4</sub> <sup>f</sup>		42:58	34:66	55
	LiClO <sub>4</sub> <sup>g</sup>		36:64	32:68	65
	PdCl <sub>2</sub> (CH <sub>3</sub> CN) <sub>2</sub> <sup>h</sup>		45:55	50:50	39

<sup>a</sup> Isomer ratio determined by weighing the purified products.

<sup>b</sup> Isomer ratio determined by integration of the <sup>1</sup>H NMR spectra.

<sup>c</sup> Purified products.

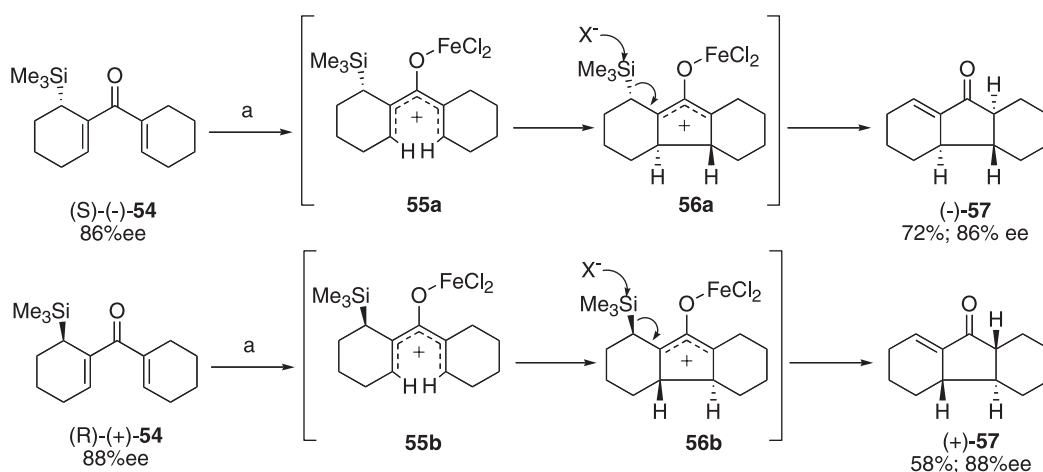
<sup>d</sup> 0.1 mol equiv, acetone/H<sub>2</sub>O.

<sup>e</sup> 1.3 mol equiv, CHCl<sub>3</sub>.

<sup>f</sup> 1.0 mol equiv, CH<sub>3</sub>CN (2% H<sub>2</sub>O).

<sup>g</sup> 1.5 mol equiv, Et<sub>2</sub>O.

<sup>h</sup> 0.2 mol equiv, acetone/H<sub>2</sub>O. All reactions proceeded for 30 min at 25 °C.



**Scheme 10.** Reaction conditions: (a)  $\text{FeCl}_3$ ,  $\text{CH}_2\text{Cl}_2$ ,  $-50^\circ\text{C}$ .

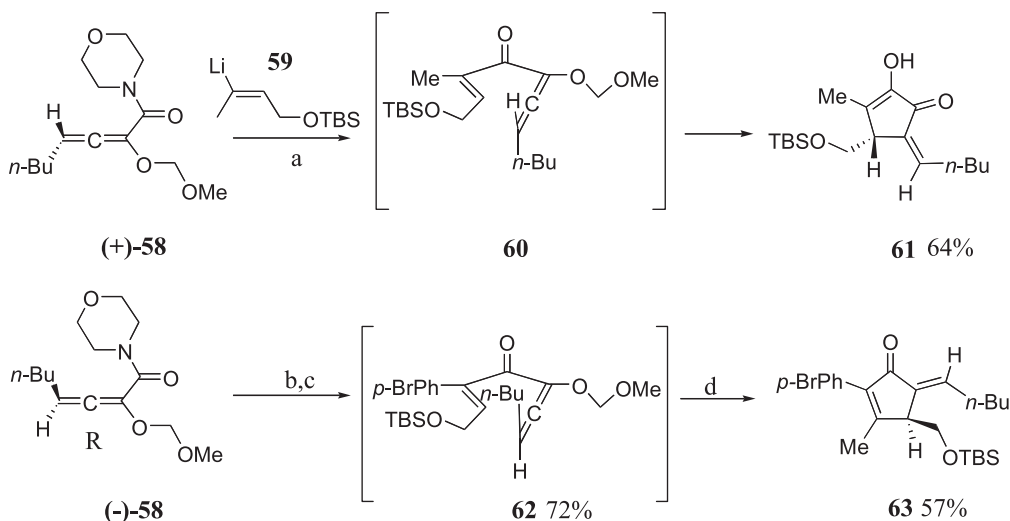
starting material. (*R*)-(+)-**54** also cyclizes selectively to oxyallyl cation **56b**, which was subsequently acted upon by the halogen to eliminate the silicon group in an anti- $S_{\text{E}}$  fashion. The resulting tricyclic (+)-**57** was obtained in 58% yield and without loss of enantiomeric excess relative to the starting material. Thus, this method exploits an in situ method for selectively preparing both enantiomers of such tricyclic systems should the prescribed enantiomerically pure  $\beta'$ -silyl compound be used.

**3.2.2. Axial to tetrahedral chirality transfer.** Allenes have been among the first substrates to be exploited as a means to facilitate stereoselectivity in Nazarov cyclizations. Should an allenyl substrate be enantiomerically pure, a bulky group at the allenyl terminus favors rotation away from the middle of the ring, allowing chirality to transfer to the new tetrahedral carbon center (refer to Section 3.1.3). Tius' group has demonstrated that the step determining the resulting stereoselectivity is cyclization, and as such, a large amount of acid is favorable in performing the reactions. Since protonation is reversible, the cyclization has to occur quickly so as not to erode the stereochemical geometry of the trisubstituted alkene. In addition, Tius'

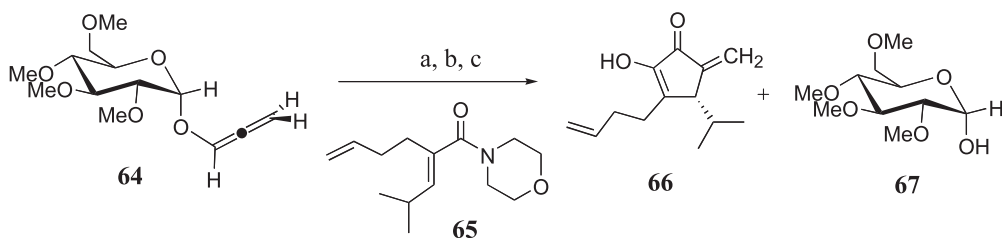
work also supports the thought that better selectivity is a result of a bulkier group on the allene terminus. Once enantiomerically pure allenenes were obtained,<sup>46</sup> treatment of (+)-**58** with vinyl lithium species **59** at  $-78^\circ\text{C}$  in THF for 30 min afforded cyclopentenone **61**<sup>47</sup> in 64% yield and 95% ee (Scheme 11). Greater than 95% chirality transfer is observed for this reaction.<sup>48</sup> In this case, the stereochemistry of the bulky *t*-butyl group favors counterclockwise rotation, allowing for efficient chirality transfer.

When (–)-**58** was converted to the phenone derivative using *p*-bromophenyllithium and then further treated with the vinyl lithium **59**, intermediate **62** was obtained. Subsequent treatment with  $\text{BF}_3 \cdot \text{OEt}_2$  at  $-78^\circ\text{C}$  facilitated the cyclization to the cyclopentenone **63** in a 57% yield with greater than 90% chirality transfer. It is also observed that isomerization of the *exo*-alkene ensues under these conditions.

**3.2.3. Traceless auxiliaries in allenyl ether cyclopentanulations.** The first exploration of enantioselective cyclization using chiral auxiliaries was carried out by Tius and co-workers. Tius explored the use of both  $\alpha$ - and  $\beta$ -anomers of allenyl pyranose derivatives to induce selectivity in the



**Scheme 11.** Reaction conditions: (a) THF,  $-78^\circ\text{C}$ , 30 min; (b) *p*-bromophenyllithium, THF,  $-78^\circ\text{C}$ , 30 min; (c) **2**, THF,  $-78^\circ\text{C}$ , 30 min, 69%; (d)  $\text{CH}_2\text{Cl}_2$ ,  $\text{BF}_3 \cdot \text{OEt}_2$ ,  $-78^\circ\text{C}$ .



**Scheme 12.** Reaction conditions: (a) *n*BuLi, (4 equiv) LiCl, THF, -78 °C; (b) -78 °C, 1 h, **2**; (c) HCl, HFIP, 0 °C; 52% yield, 68% ee (or HCl, EtOH, -78 °C; 67% yield; 67% ee).

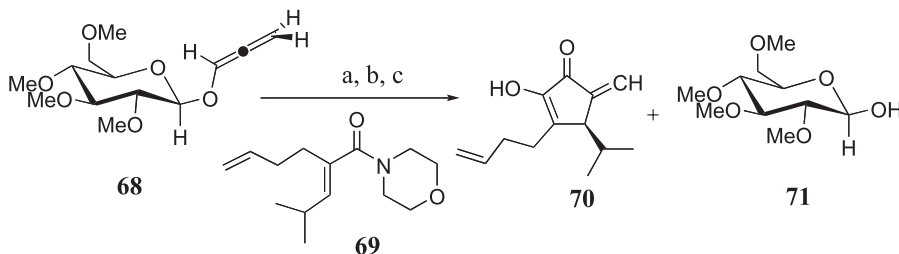
resulting cyclopentenones.<sup>49</sup> As expected, such cyclizations proceed enantioselectively and involve the loss of the sugar residue as a stable oxocarbenium species. These methods provide a route to both enantiomers in good yields with moderate enantiomeric excess.

D-Glucose was examined first due to its availability and low cost. The  $\alpha$ -anomer of the allene **64** was deprotonated to the allenyllithium, then treated with the morpholino amide **65** at -78 °C for 1 h (Scheme 12). The cyclization was induced by treatment with HCl and HFIP at 0 °C. The cyclopentenone **66** was obtained in 52% yield and 68% ee. A noticeable decline in the nucleophilicity of this allenyllithium species (in contrast to the methoxy-substituted allenyllithiates) made it necessary to use multiple equivalents of LiCl to effect a reasonable yield.<sup>50</sup> Under these optimized conditions, many different morpholino amides were tested, varying alkyl substituents of the  $\alpha,\beta$ -alkene. In these cases, yields ranged between 42 and 71% with an enantiomeric excess range of 41–67%.

The  $\beta$ -anomer was then prepared and cyclopentannulation studied (Scheme 13). The allenyllithiate of **68** is actually less reactive than that of **64**. Therefore, warming to -40 °C was necessary to drive the reaction to completion. Once the lithiate was introduced to the morpholino amide and the adduct cyclized under acidic conditions, the cyclopentenone **69** was observed in 71% yield and 82% ee.

In addition to the poor nucleophilicity observed for lithiates **64** and **68**, scalability of these reactions is also problematic. It appears that when these reactions are scaled up from 0.2 to 4.0 mmol, a noticeable deterioration of enantioselectivity occurs. It is clear that exploration of other chiral auxiliary options is needed.

**3.2.4. Asymmetric cyclization with conventional chiral auxiliaries.** Tius' group continued to examine alternative chiral auxiliaries to induce selectivity in cyclopentannulations.



**Scheme 13.** Reaction conditions: (a) *n*BuLi, LiCl, THF, -78 °C; (b) -78 °C, 1 h, **2a**, warm to -40 °C, 1 h, cool to -78 °C; (c) HCl, HFIP, 0 °C; 71% yield, 82% ee (or HCl, EtOH, -78 °C 79% yield; 61% ee).

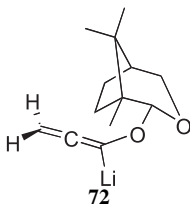
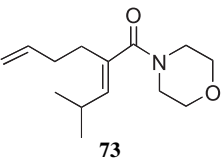
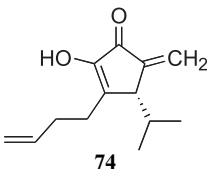
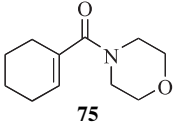
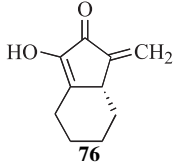
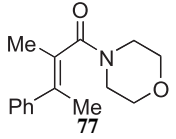
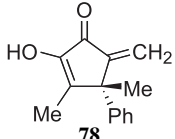
In doing so they studied the effects of camphor-derived chiral auxiliaries on these modified Nazarov cyclizations.<sup>51</sup> It was discovered that in using these camphor-derived auxiliaries on the allene (Table 4), the observed limitations in the pyranose cases involving decreased nucleophilicity and scalability were eliminated. The camphor allenyllithiate **72** and morpholino amide **73** were cyclized on a 1.0 g scale without diminishing the enantiomeric excess (entry 1). The cyclopentenone product *ent*-**74** was obtained in 78% yield with 86% ee.

Optimization revealed that a more polar solvent and lower temperatures give better enantiomeric excesses. Therefore a 1:1 HFIP/TFE solvent mixture at -78 °C was used for all subsequent reactions. TFE was added so that the reaction could be done at -78 °C. Under these optimized reaction conditions, Tius' group studied a wide variety of morpholino amides and recognized a vast improvement when using these camphor-derived auxiliaries relative to the pyranose auxiliaries. It is apparent in the better yields observed (33–84%) as well as better ees (55–87%).

Further studies by Tius showed that increased branching at the  $\beta$ -carbon of the amide improved enantioselectivity. In these cases, enantiomeric excesses are often above 80%. The Tius group also found that phenyl substitution at one or both  $\alpha,\beta$ -alkene carbons is tolerated. Additionally, substitution at the  $\alpha$ -alkene carbons with a silyl group or halogen is also a viable process. This stereoselective method involving camphor derived allenes also proved useful in preparing fused carbocycles that could facilitate the enantioselective construction of many natural product syntheses (entry 2).

Tius reported the following potentially important discovery: cyclopentannulation initiated by the reaction of allenyllithiate **72** and  $\beta,\beta$ -disubstituted amide **77** revealed the cyclopentenone **78** in a 14% yield and 65% ee (entry 3). Although the yields were very low (a large amount of the

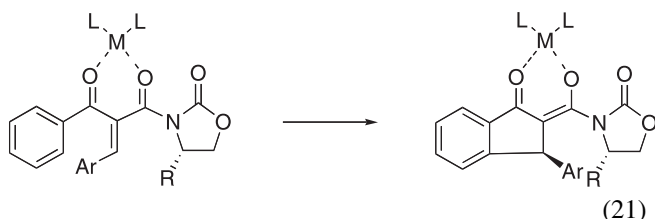
**Table 4.** Cyclizations using camphor-derived auxiliaries<sup>a</sup>

Entry	Allenyllithium	Substrate	Product	Yield	ee
1				78%	86%
2	72			62%	69%
3	72			14%	65%

<sup>a</sup> (i) **10**,  $-78$  to  $-30$  °C, 1 h; (ii) HCl, HFIP/TFE (1:1),  $-78$  °C.

amide was recovered), the reaction is significant because it shows that such cyclizations can afford quarternary carbons enantioselectively. Overall, the approach using camphor-derived auxiliaries offer better yields and selectivities than that using the pyranose-derived auxiliary and have proven to be quite general for many systems.

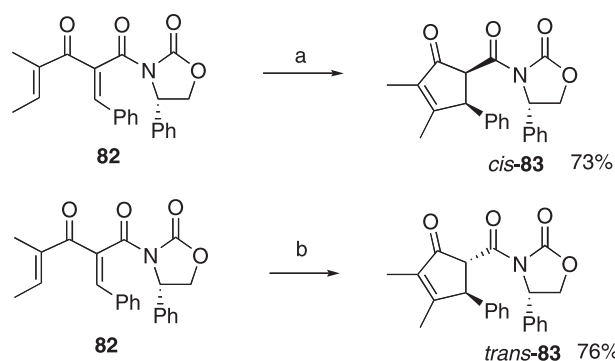
Intending to improve upon the selectivity in Nazarov-type cyclizations using metal–carbonyl coordination (Eq. 21), Pridgen and his co-workers used a commercially available *S*-oxazolidinone and 8-phenylmenthol as their chiral auxiliary for their systems (**79a–79b**).<sup>52</sup> In contrast to the camphor-derived auxiliary studies done by Tius, Pridgen's starting compounds are not allenes but they do bear a specific alkenyl geometry prior to cyclization.



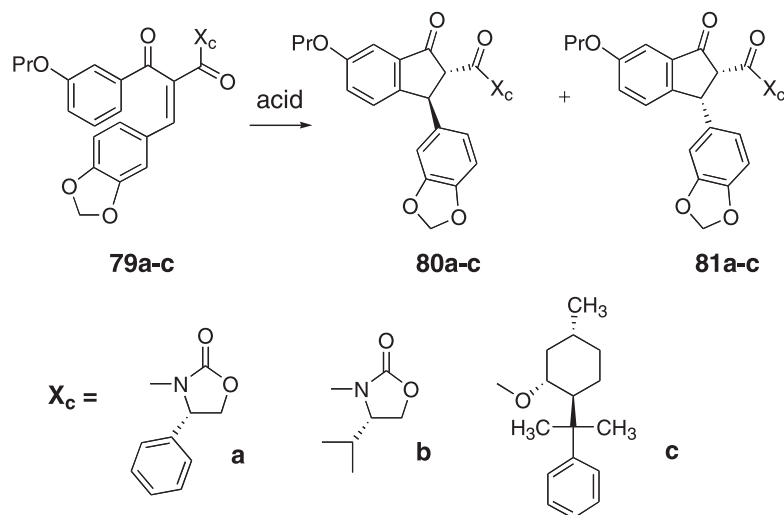
Since these Nazarov cyclization examples undergo  $4\pi$ -conrotation, torquoselectivity suggests the possibility of eight isomers. Of these, only three isomers were observed. Table 5 shows that when **79a–c** are subjected to acidic conditions in either dichloromethane or toluene at 0 °C regardless of which chiral auxiliary was installed, the major product is always the *trans* diastereomer **80a–c**. The *cis* isomer **81a–c** was also isolated and characterized in all cases along with an uncharacterized third isomer. Interestingly, both protic acids and Lewis acids can be used with both the oxazolidinone auxiliaries and the 8-phenylmenthol auxiliary. The optimized reaction conditions for the oxazolidinone derivatives requires methanesulfonic acid as the promoter. Conversely, the best results for the 8-phenylmenthol derivative were with  $\text{SnCl}_4$  as the Lewis acid promoter.

Surprisingly, the use of a protic acid with the oxazolidinone derivatives in addition to the success of the 8-phenylmenthol derivative as an auxiliary suggests that the acid promoter does not need to engage in coordination to achieve high diastereoselectivity. Instead, Pridgen asserts that the selectivity is thought to arise from the *transoid* geometry of the imide, which is thought to position the exocyclic  $\beta$ -carbon in an optimal configuration for  $4\pi$  electrocyclic cyclization (see **79**). Additionally, there is no evidence for electronic participation by the chiral auxiliary in the form of  $\pi$ -stacking, due to the absence of a carbonyl in **79c** and the absence of a phenyl group in **79b**. The Nazarov cyclization of **79a** was utilized in the synthesis of SB 209670 and SB 217242.<sup>53</sup>

Further applications of such oxazolidinones as auxiliaries in Nazarov cyclizations have been reported by Flynn and co-workers. They discovered that when **82** is reacted with  $\text{MeSO}_3\text{H}$  at  $-78$  °C and then warmed to 0 °C, *cis*-**83** is obtained upon quenching in 73% yield (Scheme 14).<sup>24</sup> This diastereomer proved to be indefinitely stable under neutral or slightly basic conditions. It was observed that epimerization of *cis*-**83** to *trans*-**83** occurred under prolonged exposure to acid at room temperature.



**Scheme 14.** Reaction conditions: (a)  $\text{MeSO}_3\text{H}$ ,  $-78$  to 0 °C then  $\text{NaHCO}_3$ ; (b)  $\text{Cu}(\text{OTf})_2$   $-78$  to 0 °C then  $\text{NaHCO}_3$  or  $\text{MeSO}_3\text{H}$ , rt, several hours.

**Table 5.** Enantioselective cyclization of **79a–c**

Substrate	Acid <sup>a</sup>	Yield (%) <sup>b</sup>	Ratio of product isomers: <b>80a–c/81a–c/other</b>
<b>79a</b>	SnCl <sub>4</sub> <sup>c</sup>	85	88:12:0
<b>79b</b>	SnCl <sub>4</sub> <sup>c</sup>	74	71:16:14
<b>79c</b>	SnCl <sub>4</sub> <sup>c</sup>	90	92:4:4
<b>79a</b>	CH <sub>3</sub> SO <sub>3</sub> H <sup>d</sup>	88	85:15:0
<b>79a</b>	TiCl <sub>4</sub> <sup>c</sup>	60	70:30

<sup>a</sup> CH<sub>2</sub>Cl<sub>2</sub> or toluene at 0 °C.<sup>b</sup> Isolated yields of the combined isomers.<sup>c</sup> 1.1 equiv.<sup>d</sup> 2.0 equiv.

When **82** is exposed to MeSO<sub>3</sub>H or cupric triflate at ambient temperature for several hours, the thermodynamically more stable *trans*-**83** is produced. This is the first report describing reaction conditions that allow selective access to either the *cis* or the *trans* cyclopentenone diastereomer in a Nazarov reaction. Since both *R* and *S* oxazolidinones are available, this method provides access to all four possible stereoisomers of the cyclopentenone ring.

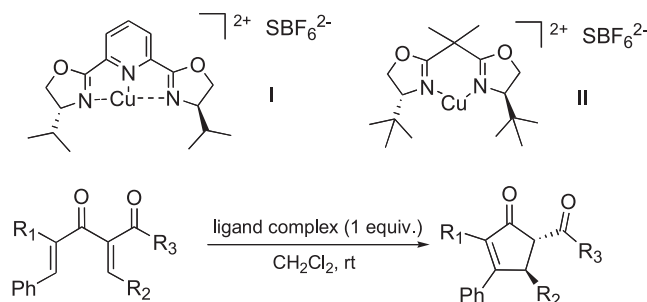
### 3.3. Enantioselective cyclization induced by external chirality: Lewis acids

In the first published study of asymmetric Nazarov cyclization using chiral Lewis acid complexes, Aggarwal

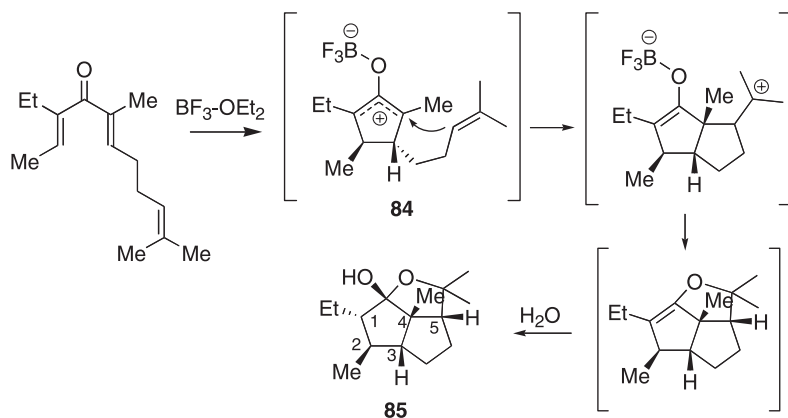
and Belfield report good yield and enantiomeric excess for four alkylidene β-ketoester substrates, using 1 equiv of promoter (Table 6).<sup>54</sup> In general, reducing the catalyst loading to 50 mol% significantly reduced yields, with no effect on enantiomeric excess (see Section 6).

### 4. Interrupted Nazarov cyclization pathways

The intermediate oxyallyl cation **3** (Eq. 1) is stable enough to suffer trapping by nucleophilic species. West has termed this the ‘interrupted’ Nazarov cyclization pathway,<sup>9</sup> and has reported a number of different examples including trapping with alkenes and arenes (Section 4.1), 1,3-dienes

**Table 6.** Cyclization promoted by chiral Lewis acids

Entry	R <sub>1</sub>	R <sub>2</sub>	R <sub>3</sub>	Ligand complex	Yield	ee
1	Me	Ph	OEt	<b>I</b>	73	76
2	Ph	Ph	OEt	<b>I</b>	98	86
3	Ph	Ph	NEt <sub>2</sub>	<b>II</b>	92	86
4	Me	Ph	NEt <sub>2</sub>	<b>II</b>	72	84



Scheme 15.

(Section 4.2), and reduction of the oxyallyl cation with hydride (Section 4.3). Cascade processes have been shown to proceed with high stereoselectivity, creating up to six stereocenters at once. Another variant of the interrupted Nazarov cyclization involves [1,2] or [3,2]-oxygen shift, and also creates multiple stereocenters with high selectivity (Section 4.4).

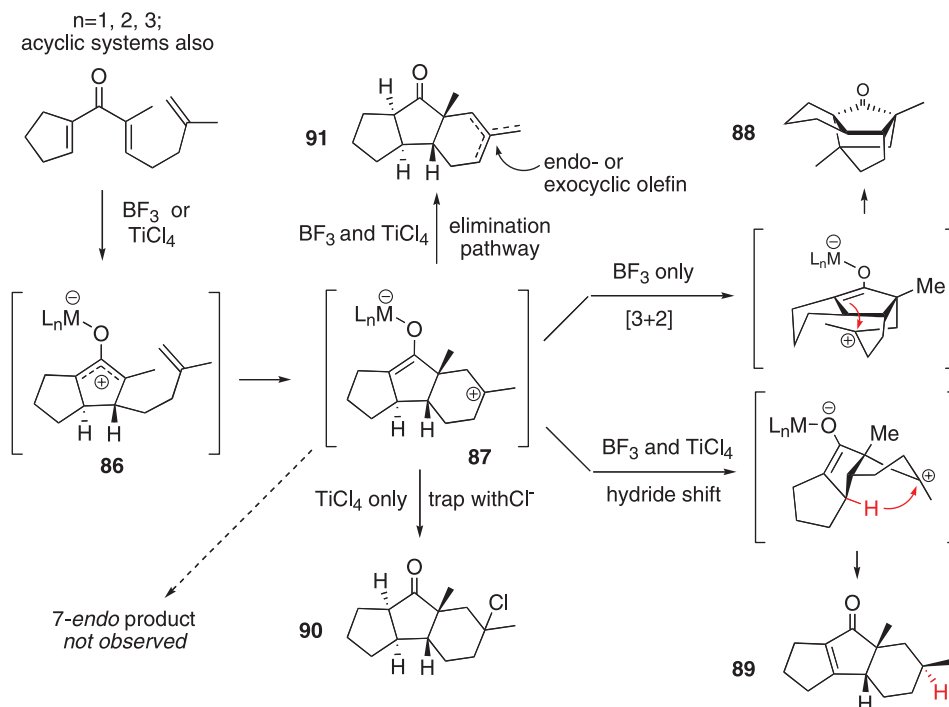
#### 4.1. Trapping of the oxyallyl cation intermediate with alkenes and arenes

The first example of interrupted Nazarov cyclization reported by West and co-workers involved trapping of oxyallyl cations like **84** with a tethered alkene (Scheme 15).<sup>9</sup> Through the intermediacy of a *cis*-fused [3.3.0] ring system, capture by an enolate oxygen followed by hydration gives products like **85**, as single stereoisomers with either four or five new stereocenters. This particular interrupted Nazarov cyclization pathway has only been observed for substrates with a two-

carbon tether between the alkene and the dienone, and with substitution at both  $\alpha$ -positions of the dienone.

With a terminal alkene on a two-carbon tether, the dominant interrupted Nazarov pathway is the 6-endo ring closure onto the oxyallyl cation **86** to give intermediate **87** (Scheme 16).<sup>55</sup> The fate of this cation has been found to lie in one of four directions: (1) attack on the enolate intermediate to give bridged product **88** (the 3+2 pathway); (2) hydride shift from a nearby carbon, to give a new carbocation that readily undergoes elimination to give **89**; (3) capture with chloride ion to give **90** (only when  $\text{TiCl}_4$  was used as catalyst) and (4) simple elimination to give alkenes **91**. The products were always formed with very high stereoselectivity, with protonation of the enolate occurring from the convex face of the bicyclic system.

This elimination pathway appears to occur only when no other species (enolate, hydride, or chloride) is in a position



Scheme 16.

**Table 7.** Examples of interrupted cyclization pathways (see Scheme 16)

Substrate	Reaction conditions	Product	Combined yield (all products)
	BF <sub>3</sub> ·OEt <sub>2</sub> (4 equiv), CH <sub>2</sub> Cl <sub>2</sub> , –78 °C, 15 min	<b>88</b> (and <b>89</b> ; 11:1 ratio)	62%
	TiCl <sub>4</sub> (1 equiv), CH <sub>2</sub> Cl <sub>2</sub> , –78 °C, 0.5 h	<b>89</b> (and <b>90</b> and <b>91</b> ; 12:1:2 ratio)	89%
	TiCl <sub>4</sub> (1 equiv), CH <sub>2</sub> Cl <sub>2</sub> , –78 °C, 0.5 h	<b>90</b> only	69%
	BF <sub>3</sub> ·OEt <sub>2</sub> (4 equiv), CH <sub>2</sub> Cl <sub>2</sub> , –78–0 °C, 1 h	<b>91</b> (and <b>88</b> ; 3.5:1 ratio)	63%
	BF <sub>3</sub> ·OEt <sub>2</sub> (4 equiv), CH <sub>2</sub> Cl <sub>2</sub> , –78–0 °C, 1 h	<b>5</b> (and <b>3</b> ; 2.7:1 ratio)	96%

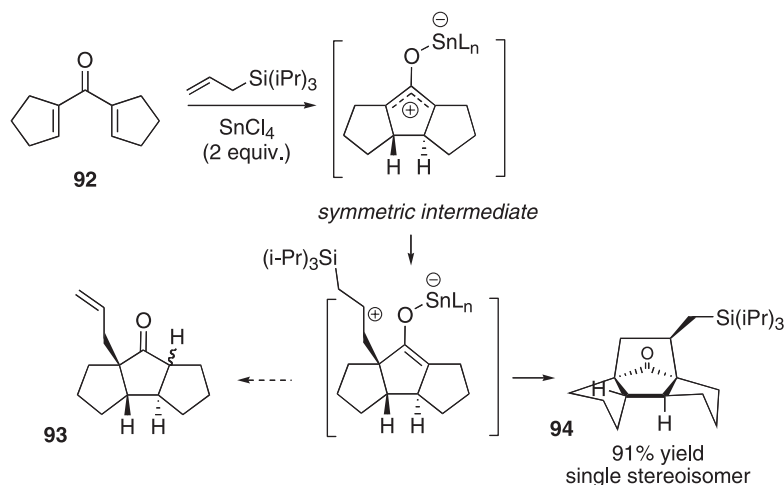
to trap the intermediate cation. Most experiments gave a multicomponent mixture of products, but moderate to high chemoselectivity can be achieved under optimized conditions. Table 7, which presents the most efficient examples of each pathway, indicates that substrate substitution was a very important factor. Although the reaction product mixtures in these early studies were usually complex, these experiments represented the first step in the development of a number of very selective processes, as discussed below.

In the first example of an intermolecular alkene interruption process, allylsilanes were used to trap the intermediate oxyallyl cation (Scheme 17).<sup>56</sup> BF<sub>3</sub> and SnCl<sub>4</sub> are the most effective Lewis acids, and the interrupted Nazarov sequence yields either the  $\alpha$ -allyl ketone of type **92** or the bridged system **93** resulting from a [3+2] cyclization, in which the allyl cation is trapped with the enolate carbon rather than undergoing desilylation. When allyl trimethylsilane was the trapping agent, a mixture of these two products was isolated

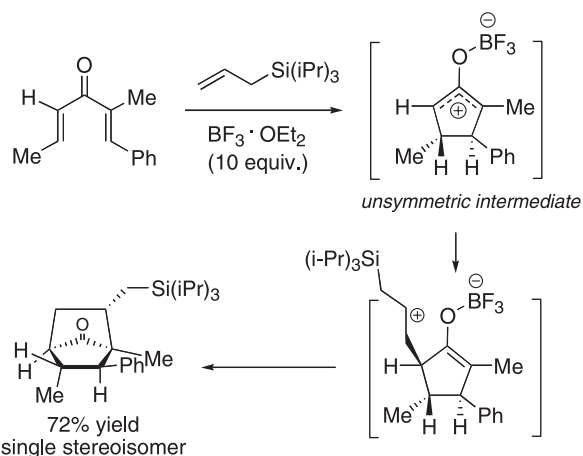
(~1:1 ratio). However, use of bulky allylsilane (*i*Pr<sub>3</sub>Si–) encouraged the formation of the [3+2] product, and the optimized reaction of the symmetric divinyl ketone **92** was highly efficient and stereoselective, since attack on the oxyallyl cation gives only the *cis*-fused [5,5]-system (Scheme 17).

When the dienone is not symmetric, allylsilane attack occurs selectively at the less substituted end of the oxyallyl cation intermediate. Facial selectivity is strongly influenced by  $\beta$ -substituents, as seen in the highly stereoselective [3+2] pathway shown in Scheme 18.

Interruption of the Nazarov cyclization with electron-rich aryl groups was the most efficient pathway studied.<sup>57</sup> The reaction is highly stereoselective and chemoselective, and effective for a wide range of substrate dienones. Using titanium tetrachloride as promoter, the reactions proceeded rapidly at low temperature to give tri- and tetracyclic products with four new stereocenters (Scheme 19). Attack

**Scheme 17.**





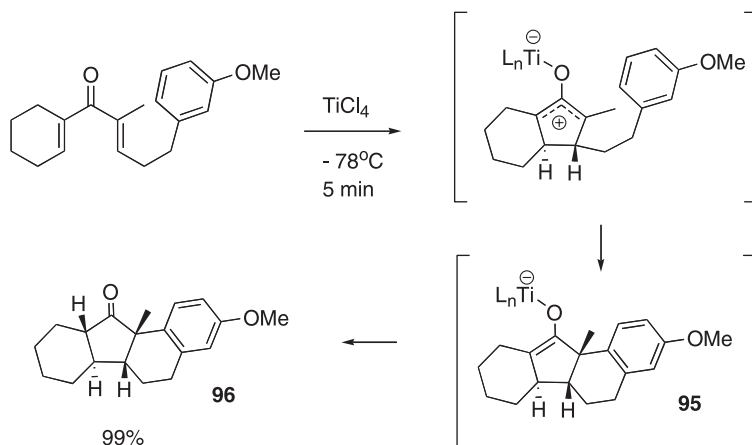
Scheme 18.

of the aromatic group on the cation always occurs *syn* to the tether, to give a *cis*-[5,6]-fused system like **95**. Protonation of the enolate occurred on the convex face of the ring system (see **96**). Interestingly, when  $\text{BF}_3 \cdot \text{OEt}_2$  was used as promoter, cyclopentenone products were observed. This indicated that under these reaction conditions, the simple elimination pathway (see **1**  $\rightarrow$  **5**, Eq. 1) was competitive with the C–C bond forming aromatic substitution pathway.

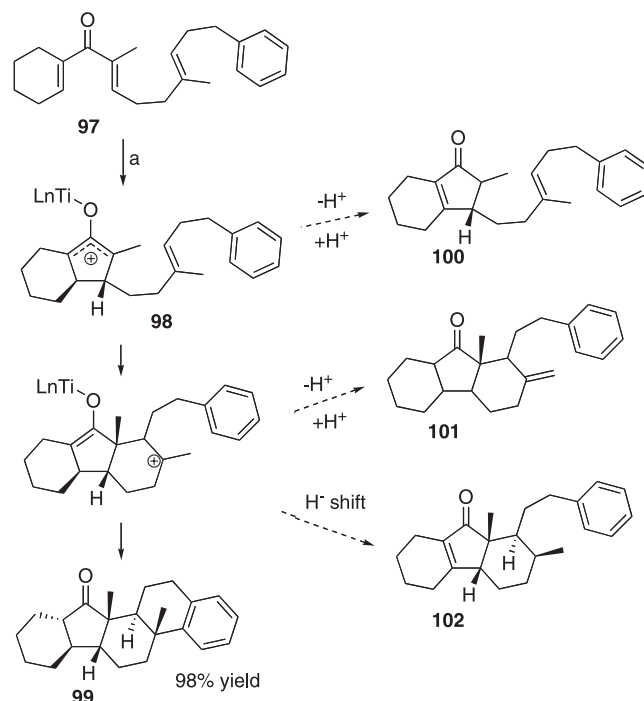
An unprecedented cationic cascade sequence triggered by Nazarov cyclization was realized for triene **97** (Scheme 20).<sup>58</sup> The process involves Nazarov cyclization and then 6-*endo* trapping with an olefin to generate cationic intermediate **98**, which was trapped by a pendant phenyl group. Six stereocenters were created with complete diastereoselectivity, to give the pentacyclic system **99** in high yield. During optimization, intermediate products of truncated cyclization were observed, including products **100** and **101** (from premature elimination both before and after the 6-*endo* cyclization step), and **102** (from hydride shift), as shown in Scheme 20.

#### 4.2. [4+3] Cycloaddition

When a 1,3-diene is tethered to the dienone, the oxyallylic cation undergoes a [4+3] cycloaddition process similar to the [3+2] pathway observed with allylsilanes (Scheme

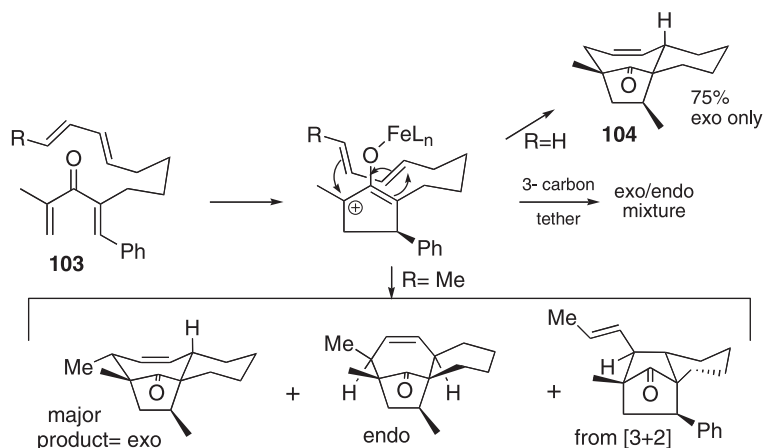


Scheme 19.

Scheme 20. Reaction conditions: (a)  $\text{TiCl}_4$  (1.1 equiv.),  $-78^\circ\text{C}$ , 5 min.

21).<sup>59</sup> Optimally, the [4+3] was triggered by  $\text{FeCl}_3$ , and cycloaddition was efficient using as little as 20 mol% of this Lewis acid. This reaction was one of the few early examples of a Nazarov-type process that can be catalyzed by Lewis acid. Dienones with  $\beta$ -substituents cyclize with complete facial selectivity, and when the tether length is four carbons (as in **103**), cycloaddition occurs with exclusively *exo* selectivity, to give a single product stereoisomer like **104**.

Substrates with other substitution patterns do not undergo [4+3] cycloaddition with such high chemo- and stereo-selectivity, but efficient conversion to new cycloadducts was still observed. For example, with a three-carbon tether, a mixture of *endo* and *exo* selectivity was observed, and when the 1,3-diene was substituted at the terminal position, the product of *exo* cycloaddition dominates, but the product mixture contained some *endo* cycloadduct and some of the [3+2] cycloadduct (Scheme 21).

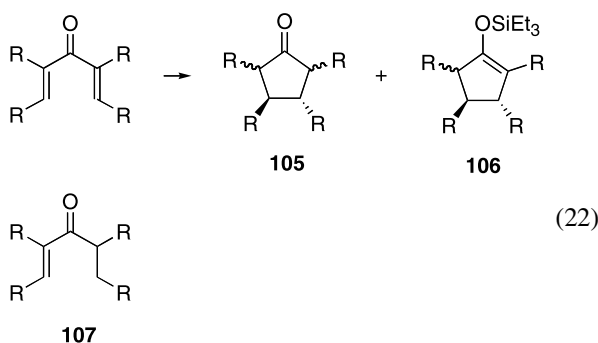


Scheme 21.

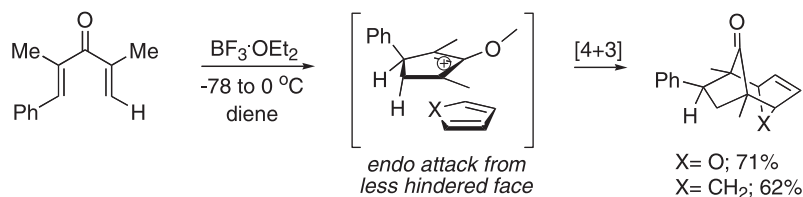
Intermolecular [4+3] cycloadditions using cyclic dienes proceed via the *endo* transition state, and facial selectivity was again controlled by substituents on the oxallyl cation, as in the intramolecular [4+3] (Scheme 22).<sup>60</sup> Trapping with the linear dienes isoprene and 2,3-dimethylbutadiene also gave the expected [4.2.1] cycloadduct in yields ranging from 50 to 93%.

### 4.3. Reductive trapping

Geise and West were able to reduce the oxallylic cation with trialkylsilane to give a saturated ketone product (Eq. 22). This is an example of interrupted Nazarov cyclization with a trapping step involving hydride rather than the  $\pi$ -system of an alkene or arene.<sup>61</sup> Ketones **105** and enol silanes **106** could be isolated in good yields (61–98%) from this reductive Nazarov cyclization process, even with just 10 mol% of the Lewis acid. The catalysis observed in this reaction is notable, as many related Nazarov cyclization sequences require at least 1 equiv of Lewis acid as promoter.



Reaction Conditions: 0.1 or 1.1 equiv.  $\text{BF}_3 \cdot \text{OEt}_2$  or  $\text{SnCl}_4$ ; 2 or 10 equiv.  $\text{Et}_3\text{SiH}$ ,  $\text{CH}_2\text{Cl}_2$ ,  $-78^\circ\text{C}$ .



Scheme 22.

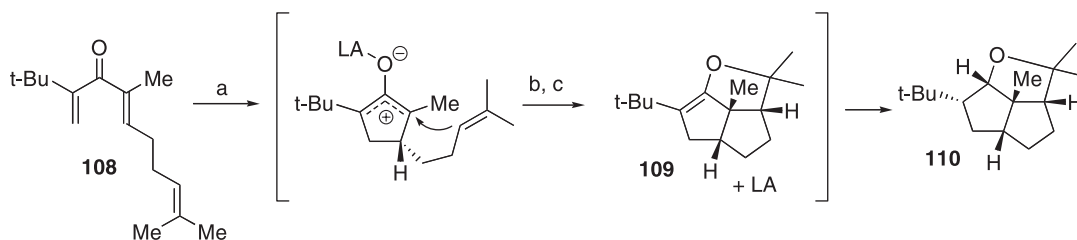
Analysis of enol silanes **106** indicates that the reduction is regioselective, occurring at the less-substituted position of the oxallyl cation. Unfortunately, even though the relative stereochemistry at the  $\beta$  carbons of the ketone product is controlled by the conrotatory cyclization, mixtures of compounds isomeric at the  $\alpha$ -positions were isolated from these reactions. Because the  $\alpha$ -centers undergo epimerization during acidic workup, the stereoselectivity of the reduction step is not known. Minor amounts of conjugate reduction product **107** were isolated in a few cases.

An experiment carried out on dienone **108** revealed that the oxallylic cation intermediate is trapped with a tethered alkene even in the presence of the trialkylsilane (Scheme 23). This interrupted Nazarov cyclization proceeds efficiently to give tricyclic enol ether **109**, which then undergoes stereoselective reduction to give ether **110**.

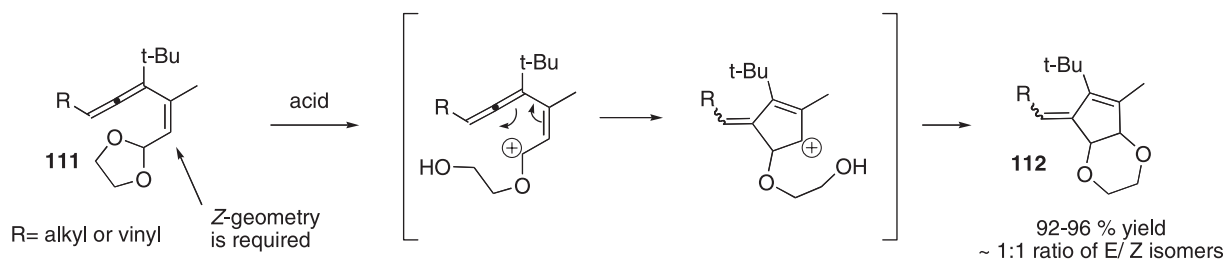
### 4.4. Intramolecular trapping with oxygen functionality

Interrupted Nazarov cyclizations involving oxygen trapping have also been reported. De Lera and co-workers reported an efficient cyclization involving a pentadienyl cation intermediate generated from a *Z*-vinyl acetal such as **111** (Scheme 24).<sup>62</sup> Protic or Lewis acid activation, cyclization and then trapping of the resultant cation with the pendant oxygen substituent gave dioxane products **112** in very high yield, as a 1:1 mixture of *E/Z* exocyclic olefins. Isolation of a 1:1 *E/Z* mixture indicated that the allene stereocenter did not encourage diastereoselective cyclization, in contrast to the trends observed in other studies (see Section 3.1.3).

A similar oxygen-interruption sequence was reported by Nair.<sup>63</sup> The pentadienyl cation was generated from Lewis acid activation ( $\text{BF}_3 \cdot \text{OEt}_2$  or  $\text{SnCl}_4$ ; > 1 equiv) of a cyclic orthoester such as **113** (Scheme 25). Nazarov cyclization



**Scheme 23.** Reaction conditions: (a)  $\text{BF}_3 \cdot \text{OEt}_2$ ,  $\text{Et}_3\text{SiH}$ ,  $-78^\circ\text{C}$ ; (b) alkene trapping; (c) oxycyclization; (d) reduction; 81% yield.



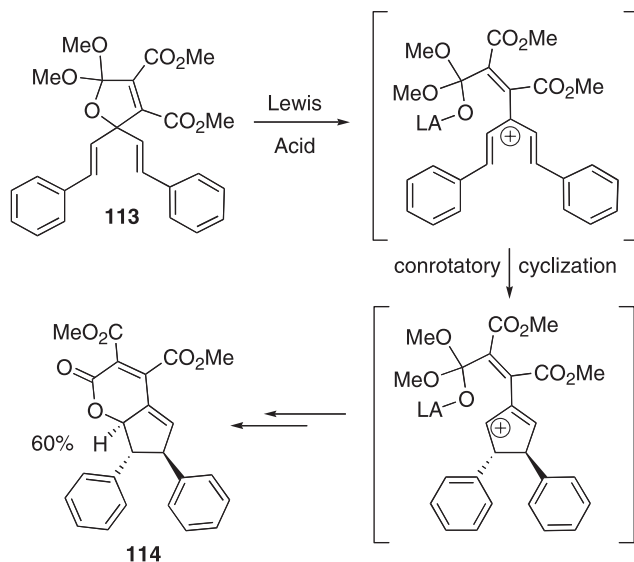
**Scheme 24.**

gave the oxyallylic cation, which was recaptured with oxygen. In situ hydrolysis led to product lactone **114** in 60–81% yield for symmetric substrates with terminal aromatic substitution. When the starting diene was not symmetric, a mixture of regioisomers was isolated, and with alkyl instead of aryl groups at the termini of the alkenes, the sequence was low-yielding.

#### 4.5. Summary

West has developed four different interrupted Nazarov pathways that create new carbon–carbon bonds and preserve the stereochemistry generated in the conrotatory  $4\text{-}\pi$  electrocyclicization, as shown in **Scheme 26**. The ultimate fate of the cationic species is dependent upon the substitution pattern of the intermediate, as indicated in the scheme caption.

Trapping with a nucleophilic species other than carbon has



**Scheme 25.** Reaction conditions:  $\text{BF}_3 \cdot \text{OEt}_2$  (1.1 equiv),  $0^\circ\text{C}$ ,  $\text{CH}_2\text{Cl}_2$ .

also been shown by West<sup>32</sup> (reduction with hydride), and by de Lera<sup>62</sup> and Nair<sup>63</sup> (trapping with oxygen). According to West's studies, the relative rates of competing Nazarov-initiated pathways was as follows: trapping by a  $\pi$ -system > reduction (trapping with a hydride) > elimination (no trapping of the intermediate cation). All interrupted Nazarov cyclizations preserved the relative stereochemistry created during conrotatory cyclization.

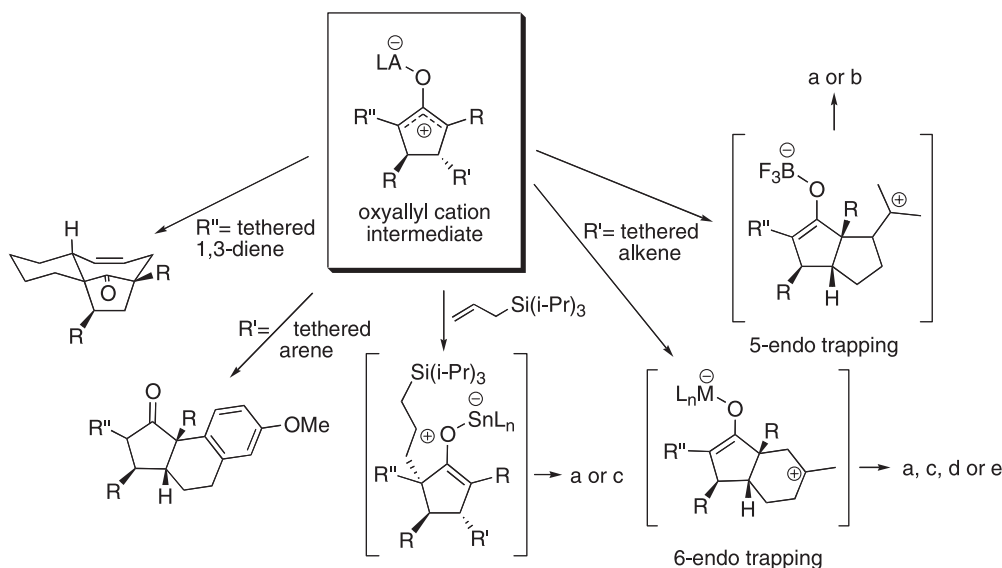
## 5. Synthetic applications

### 5.1. ( $\pm$ )-Trichodiene

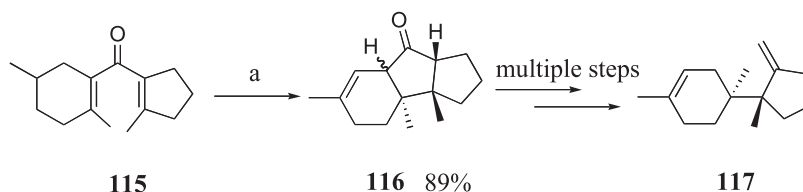
Trichodiene (**117**) is a biogenetic precursor of the biologically active trichothecenes.<sup>64</sup> Although a variety of syntheses have been reported for this natural product, Harding and co-workers investigated a novel noteworthy approach to its construction (**Scheme 27**). The synthesis of trichodiene is mired by its two challenging chiral quaternary centers. As such, Harding used a Nazarov cyclization in order to capitalize on the stereochemical control gained by an electrocyclic intramolecular approach. The disadvantage to this strategy is the necessity to cleave the ring that the Nazarov cyclization formed in order to obtain the natural product.

Keto-diene **115** was treated with a  $\text{BF}_3 \cdot \text{OEt}_2$  to obtain an 89% yield of the desired tricycle **116** (**Scheme 27**). It should be noted that the reaction was very sluggish and required a reactivity time of three days as well as 10 equiv of Lewis acid.

Regioselective deprotonation into the six-membered ring was observed to afford the olefin. An NMR spectrum of the Nazarov product **116** showed a 2.4:1 mixture of diastereomers. Since this center would later be destroyed by the cleavage of the ring, both diastereomers could be brought on to complete the final product **117**. With the relative stereochemistry of the quaternary centers established, cleavage of the undesired bond between the carbonyl and



**Scheme 26.** Interrupted Nazarov cyclization pathways with carbon–carbon bond formation. Fates of the cation following the initial interruption step: (a) elimination to give alkene; (b) cation capture by the enolate oxygen; (c) cation capture by the enolate carbon (formal [3+2] cyclization); (d) intramolecular hydride shift, then elimination to alkene; (e) cation capture by halide.

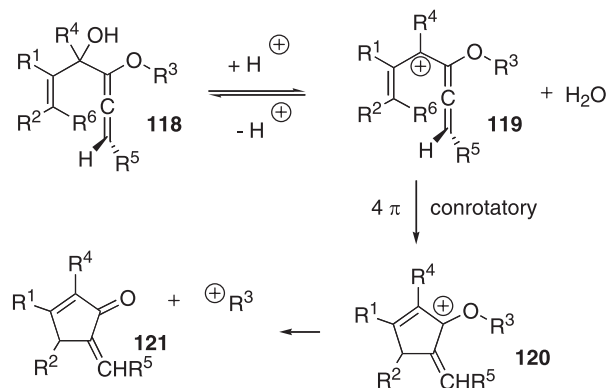


**Scheme 27.** Reaction conditions: 10 equiv  $\text{BF}_3 \cdot \text{OEt}_2$ ,  $\text{CHCl}_3$ , heat, 3 days.

the six-membered ring to afford the product was all that remained. This unconventional use of the Nazarov cyclization to afford such carbon skeletons exemplifies the scope of the reaction beyond its use in constructing cyclopentenones.

## 5.2. Nazarov cyclizations initiated by acid-catalyzed dehydration of a tertiary alcohol

Efforts using allenyl systems in Nazarov cyclizations to construct natural products were pioneered by Tius and co-workers. Scheme 28 illustrates the mechanism incorporated in the construction of both ( $\pm$ ) xanthocidin and 15-deoxy-12-hydroxy-10-(trifluoromethyl)- $\Delta^7$ -PGA<sub>1</sub> methyl ester. In

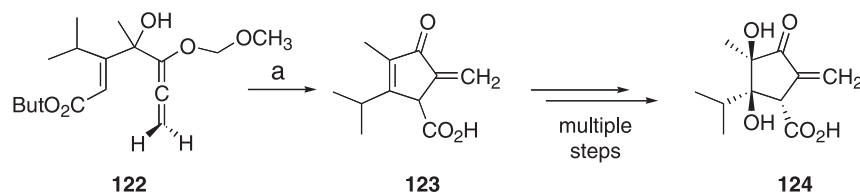


**Scheme 28.** General mechanism for cyclopentannulation of allenyl vinyl alcohols.

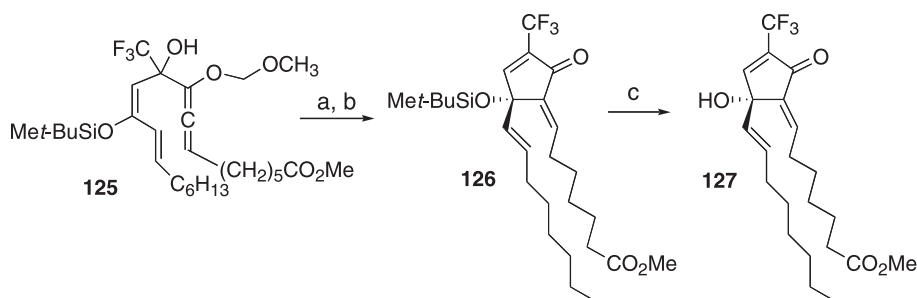
this approach, the protic acid reversibly generates cation **119** upon the loss of water, followed by thermally allowed  $4\pi$  conrotation producing the allylic carbocation **120**. Cyclopentenone **121** is formed upon the in situ loss of a stable cation, which in the following two cases was a methoxymethyl cation.

**5.2.1. ( $\pm$ )-Xanthocidin.** Tius and co-workers designed a racemic synthesis of ( $\pm$ )-xanthocidin (**124**; Scheme 29).<sup>65</sup> This natural product is a complex antibiotic that is unstable under both basic and acidic conditions. Although many synthetic efforts have been studied, ( $\pm$ )-xanthocidin remains an important compound for synthetic investigations since the bacterial strain from which this product was discovered is no longer capable of synthesizing the molecule. Thus, synthesis is the only viable source for this highly bioactive compound. Beginning with the advanced allenyl intermediate **122**, cyclization proceeds with assistance from the methoxy group to afford the enantiomeric cyclopentenone **123** in 62% yield.

**5.2.2. 15-Deoxy-12-hydroxy-10-(trifluoromethyl)- $\Delta^7$ -PGA<sub>1</sub> methyl ester.** Tius and co-workers aimed to construct 15-deoxy-12-hydroxy-10-(trifluoromethyl)- $\Delta^7$ -PGA<sub>1</sub> methyl ester **127**, a derivative of a prostaglandin (PG) compound that would still exhibit antitumor activity. Prior to the work done by Tius, PG compounds were synthesized via methods that could not be adapted to installing a tertiary hydroxyl moiety. As a result, Tius' group incorporated a Nazarov cyclization that could result



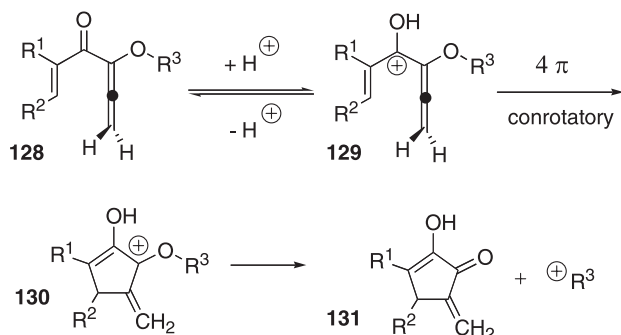
Scheme 29.

Scheme 30. Reaction conditions: (a) 2,6-lutidine, TFAA,  $-78$ – $-40$  °C; (b) PhH, sunshine; 45%; (c) TREAT·HF, Et<sub>3</sub>N, MeCN, 60 °C, 2 days; 76%.

in this desired hydroxyl placement.<sup>66</sup> As shown in Scheme 30, the allenylvinyl alcohol **125** is cyclized using 2,6-lutidine and TFAA followed by exposure to sunlight to afford a 45% yield of the *E* isomer **126**. The sunlight was necessary in order to isomerize the *Z* olefin alpha to the ketone to the desired *E* geometry. The silyloxy ether was deprotected to give the target compound **127** in 76% yield. This synthesis stands as a useful example for constructing the PG skeleton in addition to installing a tertiary hydroxyl group at the needed carbon center.

### 5.3. Nazarov cyclizations of alkoxyallenyl vinyl ketones

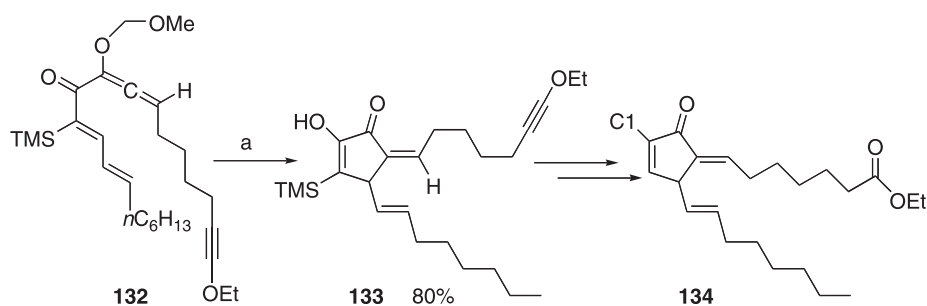
Tius and co-workers have often used the Nazarov cyclization with allenyl divinyl ketones to generate advanced intermediates in the syntheses of natural products. Scheme 31 outlines a general mechanism for the cyclization strategy that was applied to roseophilin, guanacastepene A, and  $\Delta^7$ -10-chloro-15-deoxy-PGA<sub>1</sub>. The protic acid reversibly generates an allenylic cation **129**, followed by thermally allowed  $4\pi$  conrotatory producing the allylic carbocation **130**. Cyclopentenone **131** is formed upon the in situ loss of a stable cation, which in most cases was a methoxy methyl cation, and in an enantioselective case was a chiral auxiliary.

Scheme 31. General mechanism for the allenyl vinyl ketone cyclization to an  $\Delta$ -hydroxy cyclopentenone.

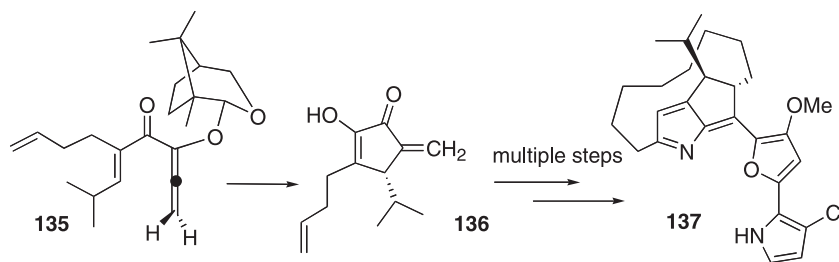
**5.3.1.  $\Delta^7$ -10-Chloro-15-deoxy-PGA<sub>1</sub> ethyl ester.** Due to their desirable bioactivity, prostaglandins (PG) have always been attractive synthetic targets. Tius and co-workers aimed to construct  $\Delta^7$ -10-chloro-15-deoxy-PGA<sub>1</sub> ethyl ester (**134**) for the purpose of developing a PG skeleton amenable to the additional installation of appropriate functionality (Scheme 32).<sup>67</sup> Upon synthesizing the allenyl vinyl ketone **132**, Nazarov cyclization gave the cyclopentenone **133** in 80% yield. It was noted that the trimethylsilyl group was necessary for successful cyclization to ensue. This unique Nazarov method for constructing PG compounds was also exploited to obtain additional prostaglandin derivatives (see Section 5.2.2).

**5.3.2. Roseophilin.** Inspired by their success in the synthesis of other naturally occurring cyclopentanoids, Tius and co-workers utilized a variant of this Nazarov reaction to construct a key intermediate in the first asymmetric total synthesis of roseophilin **137** (Scheme 33).<sup>29</sup> The reaction involves the generation of a non-isolable allenyl ketone **135**, which bears a chiral camphor auxiliary capable of controlling the direction of conrotation (see Section 3.2.4). Under mild acidic workup conditions, this allenyl ketone is cyclized to cyclopentenone **136** in 78% yield and 86% ee.

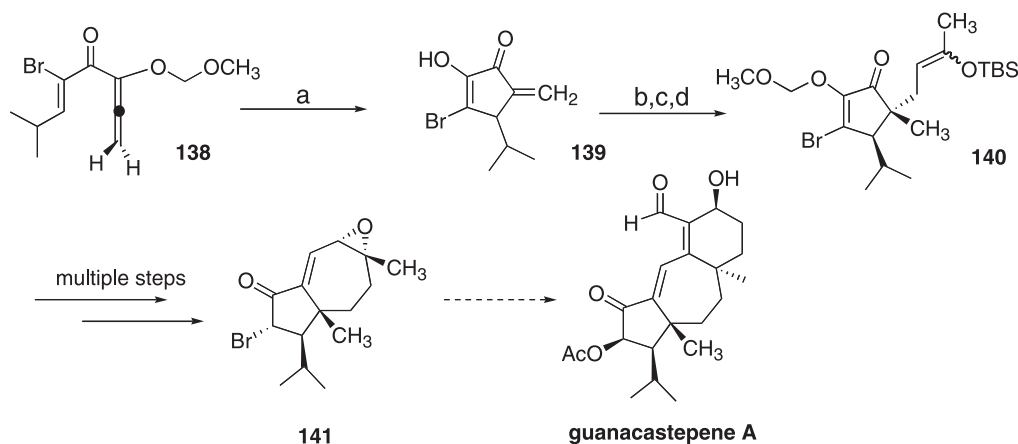
**5.3.3. Hydroazulene portion of guanacastepene A.**<sup>68</sup> The novel carbon skeleton of guanacastepene A, and particularly its two quaternary stereogenic centers, presents formidable synthetic challenges. Although many approaches to this compound have been reported, only one example of its racemic total synthesis has been accomplished.<sup>69</sup> The strategy for the construction of the hydroazulene portion of guanacastepene A (**141**) reported by the Tius group involved the formation of the cyclopentanone followed by the construction of the fused seven-membered ring (Scheme 34).<sup>70,71</sup> Under acidic conditions, methoxy-assisted cyclization of **138** gave a racemic cyclopentannulation product **139** in 75% yield. Cyclopentenone **140** was attained via protection of the enol followed by catalytic hydrogenation of the exocyclic olefin.  $\alpha$ -Deprotonation using LDA followed by reaction with methyl vinyl ketone and further



**Scheme 32.** Reaction conditions: (a) THF, Et<sub>2</sub>O, −78 °C.



**Scheme 33.** Reaction conditions: (a) HCl, HFIP/TFE (1:1), −78 °C; 78, 86% ee.



**Scheme 34.** Reaction conditions: (a) THF, −78 °C, 2.5 h; add HCl in EtOH, warm to 0 °C; 75%; (b) 1.7 equiv MOM-Cl, 2.0 equiv (*i*Pr)<sub>2</sub>Net, CH<sub>2</sub>Cl<sub>2</sub>, 0 °C, 1.5 h; (c) 5% Rh on Al<sub>2</sub>O<sub>3</sub>, EtOH, 1 atm, H<sub>2</sub>, rt, 1.5 h, 81%; (d) (1) THF, 1.6 equiv LDA, −78 °C, 45 min, (2) add 1.5 equiv MVK, warm to −40 °C, 15 min, cool to −78 °C, (3) 1.5 equiv TBSOTf, 62%.

silyl trapping afforded the cyclopentenone **140** in a 62% yield as a single diastereomer over the three steps.

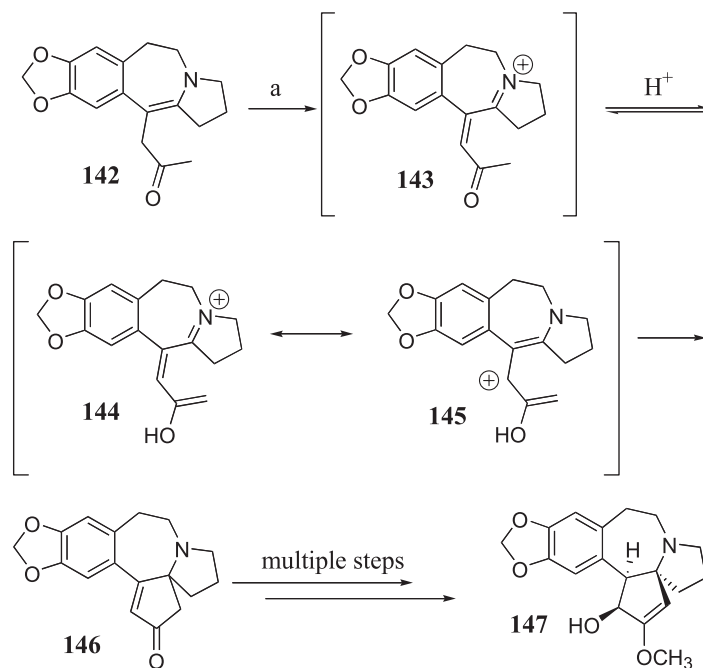
#### 5.4. Cephalotaxine (CET)

Cephalotaxine (**147**) is a biologically active member of the *Cephalotaxus* alkaloids. Although many syntheses have been employed to obtain CET, more efficient methods for its construction may facilitate clinical studies of derivatives. While exploring the utility of the enamine **142** as an intermediate toward the total synthesis of cephalotaxine, Kim and Cha discovered an aza-Nazarov-type cyclization (Scheme 35).<sup>11</sup> Upon treatment with hot acetic acid and exposure to air, **142** was converted to a single isolable pentacyclic enone **146** in a 30% yield. Enamine **142** was oxidized to the conjugated iminium intermediate **143**, which under the acidic conditions tautomerizes to the allyl cation **144**. Electrocyclic cyclization gives solely the desired

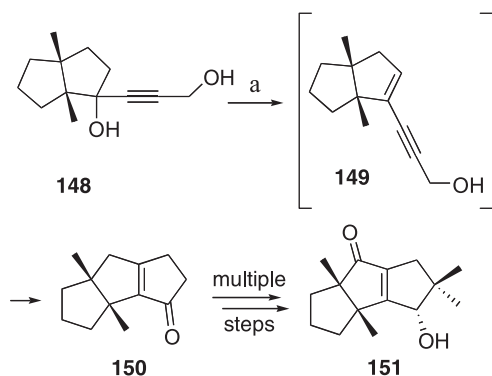
cyclopentenone **146**. Further optimization led to the use of air, a stoichiometric portion of FeSO<sub>4</sub>, and glacial acetic acid as the solvent, to afford the product **146** in a 57% yield. This acid-catalyzed, oxygen-dependent cyclization offers a viable route toward the natural product via readily available intermediate **142**.

#### 5.5. Cucumin H

The sesquiterpene natural product cucumin H (**151**) was isolated in 1998; however, not enough of the compound was available to allow the assignment of absolute stereochemistry. The absolute configuration for cucumin H was established upon its enantioselective total synthesis.<sup>72</sup> The authors took advantage of a modified Nazarov cyclization to construct the tricyclic fused ring in this cyclopentanoid (Scheme 36). The advanced intermediate diol **148**, was treated with Eaton's reagent<sup>73</sup> to afford the conjugated



**Scheme 35.** Reaction conditions: (a) glacial acetic acid, FeSO<sub>4</sub>, air, 57%.



**Scheme 36.** Reaction conditions: (a) P<sub>2</sub>O<sub>5</sub>, MsOH (4 equiv), rt, CH<sub>2</sub>Cl<sub>2</sub>, 1 h, 70%.

alkyne **149**. In aqueous acid, this compound rearranged to give the triquinane **150** in a 70% yield.<sup>74</sup> Further transformations of this  $\alpha,\beta$ -unsaturated ketone selectively afforded the natural product **151**.

Other noteworthy Nazarov approaches toward triquinane natural products were accomplished by Stille and co-workers in the synthesis of ( $\pm$ )- $\Delta^{9(12)}$ -capnellene<sup>75</sup> and by Neumann and co-workers in the synthesis of ( $\pm$ )-silphinene.<sup>76</sup>

## 6. Catalysis of Nazarov cyclization

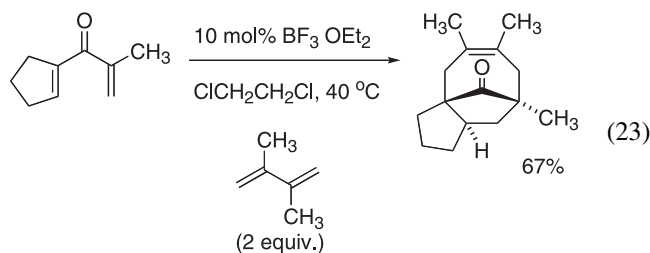
Until recently, optimal Nazarov cyclization conditions involved stoichiometric Lewis acid, often with a strong promoter (such as BF<sub>3</sub>, SnCl<sub>4</sub>, TiCl<sub>4</sub> and AlCl<sub>3</sub>). These findings suggested that the Lewis acid-complexed enolate **4** (Eq. 1) was too stable to undergo the protonation step required for efficient release of the Lewis acid, preventing catalytic turnover. The design of highly reactive divinyl ketones has led to electrocyclizations catalyzed by a number

of mild Lewis acids. These findings pave the way for the development of catalytic asymmetric Nazarov cyclizations. As yet, no system allowing efficient and general enantioselective cyclization has been reported, but promising advances have been made toward this goal.

### 6.1. Early work

The original examples of catalytic Nazarov cyclization with non-protic Lewis acids were disclosed as part of the studies of Denmark and West. Denmark and Jones found that silicon-directed Nazarov cyclizations proceeded with reduced rate but equal efficiency with 40–50 mol% FeCl<sub>3</sub>, but that with 10 mol% catalyst, conversion and reaction rate were poor.<sup>41</sup> West found that in some cases, interrupted Nazarov cyclizations could be conducted with catalytic amounts of Lewis acid. For example, the reductive cyclization process, normally conducted with 1.1 equiv of BF<sub>3</sub>-OEt<sub>2</sub>, could also be achieved with 10 mol% BF<sub>3</sub>-OEt<sub>2</sub> or SnCl<sub>4</sub>.<sup>32</sup> Yields were slightly diminished for the catalytic process.

Results of [4+3] cyclization were even more promising: the intramolecular Nazarov-initiated process with 20 mol% FeCl<sub>3</sub> is just as efficient as cyclization with stoichiometric Lewis acid, and the reaction shown in (Eq. 23) is more efficient with 10 mol% BF<sub>3</sub>-OEt<sub>2</sub> than with 1 equiv of the promoter.<sup>59,60</sup>



**Table 8.** Lewis acid-catalyzed Nazarov cyclization

Entry	Substrate	Product	Catalyst	Reaction conditions	Yield (%)	Reference
1			2 mol% Cu(OTf) <sub>2</sub>	Cl(CH <sub>2</sub> ) <sub>2</sub> Cl, rt	99	20
2			2 mol% Cu(OTf) <sub>2</sub>	Cl(CH <sub>2</sub> ) <sub>2</sub> Cl, 55%	99	20
3			10 mol% AlCl <sub>3</sub>	CH <sub>3</sub> CN, rt	90	12
4			10 mol% AlCl <sub>3</sub>	CH <sub>2</sub> Cl <sub>2</sub> , rt	91	12
5			2 mol% PdCl <sub>2</sub> (MeCN) <sub>2</sub>	Wet acetone, rt	70	21
6			20 mol% Pd(OAc) <sub>2</sub>	DMSO, O <sub>2</sub> , 80 °C	63 (74)	21
7			10 mol% PdCl <sub>2</sub> (MeCN) <sub>2</sub>	Wet acetone, rt	74	21
8			10 mol% PdCl <sub>2</sub> (MeCN) <sub>2</sub>	Wet acetone, rt	90	21
9			50 mol% I <sup>a</sup>	CH <sub>2</sub> Cl <sub>2</sub> , rt	96	54
10			50 mol% I <sup>a</sup>	CH <sub>2</sub> Cl <sub>2</sub> , rt	86	54

<sup>a</sup> See Section 3.3.

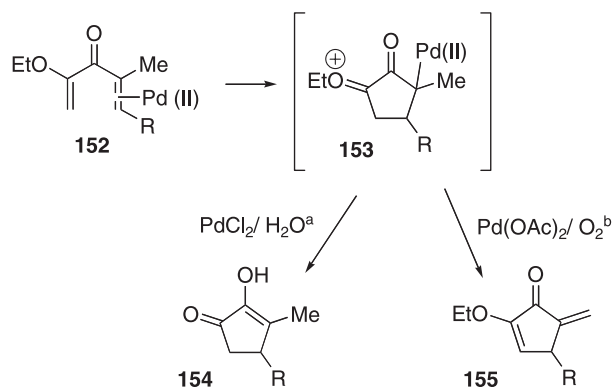
## 6.2. Catalysis with polarized substrates

Soon after this report, three research groups independently disclosed that electronically unsymmetric divinyl ketones are highly reactive in the catalytic Nazarov cyclization (Section 2.2). These groups found that an oxygen substituent at the 2-position of the dienone is particularly important. A wide range of these substrates undergoes efficient Nazarov cyclization, and several different Lewis acids are able to catalyze the reaction. The optimal substrate/catalyst pairings that were reported by the three groups are presented in Table 8. Comparison of these results indicates that for most substrates studied, efficient turnover occurred when 2–10% of the appropriate catalyst was employed. A fourth group reported that alkyldiene β-ketoester substrates undergo cyclization with 50 mol% of

catalyst (entries 9 and 10), but turnover was slow in many cases.<sup>54</sup> For nearly all substrates in this class, using 1 equiv of promoter significantly improves reaction results.

The reactions shown in entries 5–8 are unusual because the Pd (II) catalyst is thought to activate an olefin rather than the carbonyl group prior to cyclization (such as complex **152**, Scheme 37). Two different reaction mechanisms leading to two different types of products (compare entries 5 and 6) were observed, depending on which Pd (II) species was used. The authors propose that cyclization gives a palladium enolate **153**, and that when PdCl<sub>2</sub>(MeCN)<sub>2</sub> is catalyst, hydrolysis generates hydrochloric acid and rapid protonation of **153** to give cyclopentenones **154**. In contrast, when Pd(OAc)<sub>2</sub> is catalyst, hydrolysis generates acetic acid allowing β-hydride elimination to compete with protonation of **153**. This pathway

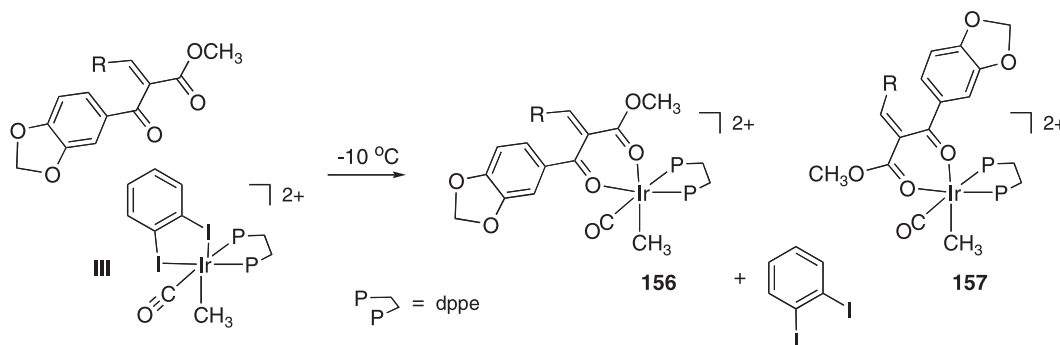




**Scheme 37.** (a) HCl is generated; protonation is rapid. (b) HOAc is generated; protonation is slow; β-hydride elimination competes.

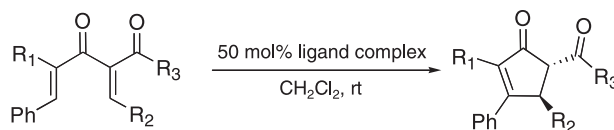
generates cyclopentenone **155**, and molecular oxygen is required to regenerate the Pd(II) catalyst.

An iridium (III) complex was also identified as a highly reactive catalyst for Nazarov cyclization (**III**, Scheme 38).<sup>13</sup> Upon dissociation of the diiodobenzene ligand, adjacent coordination sites become available for complexation to the substrate. The high Lewis acidity of the cationic iridium center allows this complex to catalyze the cyclization at low temperature and catalyst loading, with excellent yields.



**Scheme 38.**

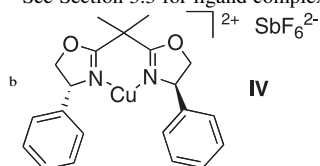
**Table 9.**



Entry	R <sub>1</sub>	R <sub>2</sub>	R <sub>3</sub>	Ligand complex <sup>a</sup>	Yield	ee
1	Me	Ph	OEt	<b>I</b>	42	78
2	Ph	Ph	OEt	<b>I</b>	96	86
3	Ph	Ph	NEt <sub>2</sub>	<b>II</b>	56	87
4	Me	Ph	NEt <sub>2</sub>	<b>II</b>	56	85
5	Ph	Ph	NEt <sub>2</sub>	<b>IV</b> <sup>b</sup>	56	86

Reaction conditions: 50 mol% ligand complex; CH<sub>2</sub>Cl<sub>2</sub>, rt.

<sup>a</sup> See Section 3.3 for ligand complexes **I** and **II**.



Preorganization of the divinyl ketone via catalyst coordination is also thought to contribute to the catalyst's efficiency.<sup>13</sup> This idea is supported by <sup>31</sup>P NMR data indicating the presence of two regioisomers (**156** and **157**) in solution prior to cyclization.

### 6.3. Asymmetric catalysis

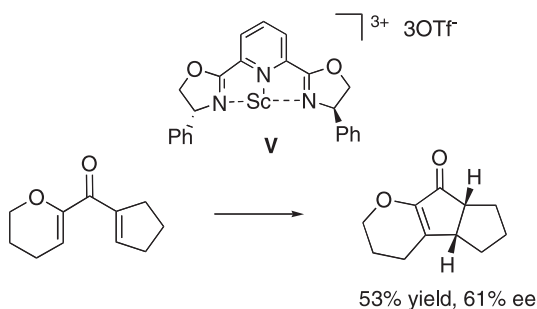
Generating an asymmetric intermediate during Nazarov cyclization has been challenging, possibly because the carbonyl group bound to the chiral promoter is spatially distant from the bond-forming event. Experiments with catalytic Lewis acid complexes permit moderate asymmetric induction at the β-position (the stereocenter formed during electrocyclization). Better results are obtained with a stoichiometric amount of chiral Lewis acid, but turnover is not efficient and yields in the catalytic regime are unsatisfactory. Excellent asymmetric induction can be obtained during the proton-transfer step at the end of the reaction sequence (Eq. 1, **4**→**5**), to give high enantiomeric excess at the position α to the ketone.

Aggarwal and Belfield had limited success with catalytic asymmetric Nazarov cyclization using copper (II) pybox complexes.<sup>54</sup> In most cases, conversion was poor with substoichiometric amounts of the complex, as shown in

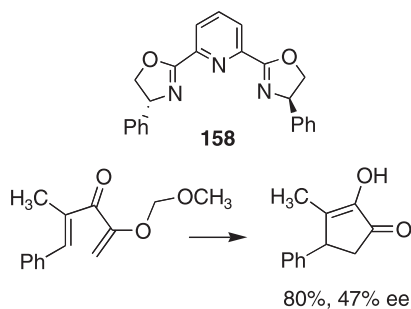
**Table 9.** More catalyst led to higher yields, but did not improve enantioselectivity (see **Table 6**, Section 3.3). The data underline the fundamental problem with these systems: catalyst turnover is difficult.

In related experiments conducted by several research groups, transition metal/ bisoxazoline complexes were found to catalyze cyclization with moderate asymmetric induction. Trauner and co-workers reported cyclization with 20 mol% of scandium(III)-pyBOX complex **V** (**Scheme 39**).<sup>12</sup> Tius and Leclerc found that complexes of ytterbium with ligand **158** allows efficient cyclization with moderate enantioselectivity (**Scheme 40**);<sup>77</sup> and Frontier and He had similar results with a complex of copper(II) with ligand **159** (**Scheme 41**).<sup>78</sup>

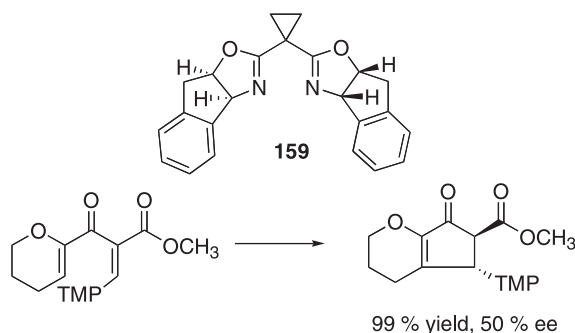
Chiral proton transfer in the final step of the process (see Eq. 1; **4**→**5**) has been observed by Trauner and Liang. This behavior was first detected during the experiment shown in **Scheme 42**.<sup>79</sup> After cyclization with scandium-bisoxazoline



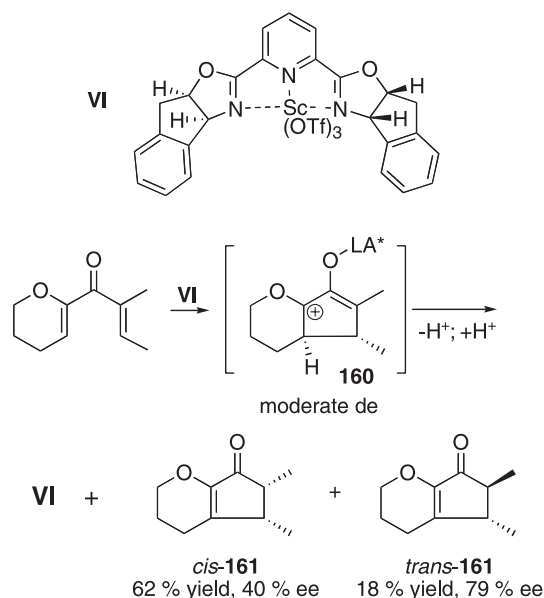
**Scheme 39.** Reaction conditions: ligand complex **V** (20 mol%), THF, rt.



**Scheme 40.** Reaction conditions: 20 mol% Yb(OTf)<sub>3</sub>, 30 mol% ligand **158**, CH<sub>2</sub>Cl<sub>2</sub>, rt, 12 h.



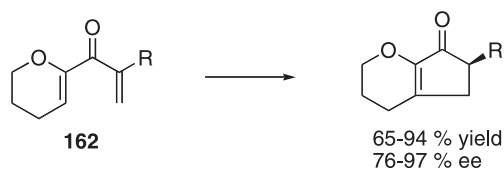
**Scheme 41.** Reaction conditions: 10 mol% Cu(OTf)<sub>2</sub>, 20 mol% ligand **159** –20 to 0 °C, toluene. TMP=2,4,6-trimethoxyphenyl. Absolute stereochemistry was not determined.



**Scheme 42.** Reaction conditions: 10 mol% catalyst complex **VI**, MeCN, 3 Å m.s., rt.

catalyst **VI**, one diastereomer of **160** evidently underwent protonation more efficiently than the other to give **trans-161** with 79% ee, whereas **cis-161** had only 40% ee. This result indicated that while the Lewis acid had allowed moderately enantioselective electrocyclicization (see **2**→**3**, Eq. 1), it had also influenced the protonation step.

Thus far, high selectivity at the β-position has not been achieved using truly catalytic amounts of chiral Lewis acids. This may be due to the fact that the chirality expected to induce asymmetric cyclization is far from the stereocenter being formed. Significantly, Trauner and co-workers also studied substrates without β-substitution (like **162**), and found that enantioselectivity of the protonation step is highly enantioselective (72–97% ees), using 10 mol% of the scandium-bisoxazoline catalyst **VI** (**Scheme 43**). This suggests that protonation is irreversible, and that the enolate-catalyst chiral environment influences the stereochemistry of reactions at the α-position more strongly than the β-position.



**Scheme 43.** Reaction conditions: 10 mol% catalyst complex **VI**, MeCN, 3 Å m.s., 0 °C or rt.

## 7. Conclusion

In the past ten years, several advances in Nazarov cyclization chemistry have improved the synthetic utility of the transformation: (1) reactive substrates undergo cyclization using catalytic Lewis acid, (2) trapping of the intermediate cation was found to be efficient, allowing preservation of both stereocenters created during

conrotatory electrocyclization, (3) chiral auxiliaries allow asymmetric cyclization, (4) axial to tetrahedral chirality transfer is possible, and (5) chiral Lewis acids allow enantioselective reactions to occur. The reaction has been featured as the key step of several syntheses of natural products, demonstrating the utility of the cyclization for application to complex molecule synthesis, and a better understanding of the factors controlling reactivity and stereoselectivity has been attained. Researchers have yet to develop a general protocol for catalytic asymmetric Nazarov cyclization, although preliminary results have been promising. The recent findings described in this review represent significant progress in the development of the reaction, and indicate that improved methods for asymmetric catalysis and increased implementation of the Nazarov cyclization in synthetic strategies are on the horizon.

### Acknowledgements

The authors thank Michael Harmata and Dirk Trauner for providing expert opinions on the chemistry in this review during its preparation. We also thank Marcus Tius for sharing unpublished results, and are grateful to M. Uljana Mayer for invaluable editorial suggestions.

### References and notes

- For the first of Nazarov's many publications in this area, see: Nazarov, I. N.; Zaretskaya, I. I. *Izv. Akad. Nauk. SSSR, Ser. Khim.* **1941**, 211–224.
- (a) Habermas, K. L.; Denmark, S. E.; Jones, T. K. *Org. React. (N.Y.)* **1994**, *45*, 1–158. (b) Santelli-Rouvier, C.; Santelli, M. *Synthesis* **1983**, 429–442. (c) Denmark, S. E. In Trost, B. M., Fleming, I., Eds.; *Comprehensive Organic Synthesis*; Pergamon: Oxford, 1991; Vol. 5, p 751.
- Woodward, R. B.; Hoffmann, R. *The Conservation of Orbital Symmetry*; Verlag Chemie: Weinheim, 1970.
- Houk, K. N. In *Strain and its Implications in Organic Chemistry*; de Meijere, A., Blechert, S., Eds.; Kluwer Academic: Dordrecht, 1989.
- Denmark, S. E.; Jones, T. K. *J. Am. Chem. Soc.* **1982**, *104*, 2642–2645.
- Denmark, S. E.; Habermas, K. L.; Hite, G. A. *Helv. Chim. Acta* **1988**, *71*, 168–194.
- Marino, J. P.; Lindermann J. *Org. Chem.* **1981**, *46*, 3696–3702.
- Andrews, J. F. P.; Regan, A. C. *Tetrahedron Lett.* **1991**, *32*, 7731–7734.
- Bender, J. A.; Blize, A. E.; Browder, C. C.; Giese, S.; West, F. G. *J. Org. Chem.* **1998**, *63*, 2430–2431.
- Tius, M. A. *Acc. Chem. Res.* **2003**, *36*, 284–290.
- Kim, S. H.; Cha, J. K. *Synthesis* **2000**, 2113–2116.
- Liang, G. X.; Gradl, S. N.; Trauner, D. *Org. Lett.* **2003**, *5*, 4931–4934.
- (a) Janka, M.; He, W.; Frontier, A. J.; Eisenberg, R. *J. Am. Chem. Soc.* **2004**, *126*, 6864–6865. (b) Janka, M.; He, W.; Frontier, A. J.; Flaschemreim, C.; Eisenberg, R. *Tetrahedron* **2005**, *61*, 6193–6206.
- Harmata, M. *Chemtracts: Org. Chem.* **2004**, *17*, 416–435.
- For exceptions, see Section 6.1.
- Casson, S.; Kocienski, P. *J. Chem. Soc., Perkin Trans. 1* **1994**, 1187–1191.
- Tius, M. A.; Kwok, C.-K.; Gu, X.-q.; Zhao, C. *Synth. Commun.* **1994**, *24*, 871–885.
- Kim, S. H.; Cha, J. K. *Synthesis* **2000**, 2113–2116.
- Occhiato, E. G.; Prandi, C.; Ferrali, A.; Guarna, A.; Venturello, P. *J. Org. Chem.* **2003**, *68*, 9728–9741.
- He, W.; Sun, X. F.; Frontier *J. Am. Chem. Soc.* **2003**, *125*, 14278–14279.
- Bee, C.; Leclerc, E.; Tius, M. A. *Org. Lett.* **2003**, *5*, 4927–4930.
- Sakai, T.; Miyata, K.; Takeda, A. *Chem. Lett.* **1985**, 1137–1138.
- The experiment shown in Eq. 3 (conditions b) may not be reproducible (see Ref. 8).
- Kerr, D. J.; Metje, C.; Flynn, B. L. *J. Chem. Soc., Chem. Commun.* **2003**, 1380–1381.
- Isomerization behavior significantly complicates the reactivity profile (Section 2.3.3). The withdrawing group may create steric interactions (see Section 2.1), or engage in two-point binding to the catalyst (Fig. 2). Both of these factors could also affect reaction rate.
- Jarvie, A. W. P. *Organomet. Chem. Rev., Sect. A* **1970**, *6*, 153.
- Hashmi, A. S. K.; Bats, J. W.; Choi, J.-H.; Schwarz, L. *Tetrahedron Lett.* **1998**, *39*, 7491–7494.
- Leclerc, L.; Tius, M. A. *Org. Lett.* **2003**, *5*, 1171–1174.
- Harrington, P. E.; Tius, M. A. *J. Am. Chem. Soc.* **2001**, *123*, 8509–8514.
- Dolbier, W. R.; Koroniak, H.; Houk, K. N.; Sheu, C. *Acc. Chem. Res.* **1996**, *29*, 471–477.
- Denmark, S. E.; Klix, R. C. *Tetrahedron* **1988**, *44*, 4043–4060.
- (a) Giese, S.; West, F. G. *Tetrahedron Lett.* **1998**, *39*, 8393–8396. (b) Giese, S.; West, F. G. *Tetrahedron* **2000**, *56*, 10221–10228.
- Denmark, S. E.; Wallace, M. A.; Walker, C. B. *J. Org. Chem.* **1990**, *55*, 5543–5545.
- He, W.; Atesin, T. A.; Frontier, A. J. Unpublished results.
- Faza, O. N.; Lopez, C. S.; Alvarez, R.; de Lera, A. R. *Chem. Eur. J.* **2004**, *10*, 4324–4333.
- Harmata, M.; Lee, D. R. *J. Am. Chem. Soc.* **2002**, *124*, 14328–14329.
- Harmata, M.; Schreiner, P. R.; Lee, D. R.; Kirchoefer, P. L. *J. Am. Chem. Soc.* **2004**, *126*, 10954–10957.
- Etheridge, Z. C.; Caddick, S. *Tetrahedron: Asymmetry* **2004**, *15*, 503–507.
- Smith, D. A.; Ulmer, C. W., II *J. Org. Chem.* **1997**, *62*, 5110–5115.
- Tius, M. A.; Chu, C. C.; Nieves-Colberg, R. *Tetrahedron Lett.* **2001**, 2419–2422.
- Jones, T. K.; Denmark, S. E. *Helv. Chim. Acta* **1983**, *66*, 2377–2396.
- Denmark, S. E.; Habermas, K. L.; Hite, G. A.; Jones, T. K. *Tetrahedron* **1986**, *42*, 2821–2829.
- Occhiato, E. G.; Prandi, C.; Ferrali, A.; Guarna, A.; Deagnostino, A.; Venturello, P. *J. Org. Chem.* **2002**, *67*, 7144–7146.
- Prandi, C.; Ferrali, A.; Guarna, A.; Venturello, P.; Occhiato, E. G. *J. Org. Chem.* **2004**, *69*, 7705–7709.
- Iglesias, B.; de Lera, A. R.; Rodriguez-Otero, J.; Lopez, S. *Chem. Eur. J.* **2000**, *6*, 4021–4033.

46. Resolution of allenes (–)-**1**, and (+)-**1** was achieved via chiral HPLC methods.
47. The absolute stereochemistry was determined by X-ray crystallographic examination of the chiral carbamate derivative. Allene (–)-**1** was assigned as (*S*) and (+)-**1** as (*R*).
48. Hu, H.; Smith, D.; Cramer, E.; Tius, M. A. *J. Am. Chem. Soc.* **1999**, *121*, 9895–9896.
49. Harrington, P. E.; Tius, M. A. *Org. Lett.* **2000**, *2*, 2447–2450.
50. Seebach, D. *Angew. Chem., Int. Ed. Engl.* **1988**, *27*, 1624–1654.
51. Harrington, P. E.; Murai, T.; Chu, C.; Tius, M. A. *J. Am. Chem. Soc.* **2002**, *124*, 10091–10100.
52. Pridgen, L. N.; Huang, K.; Shilcrat, S.; Tickner-Eldridge, A.; DeBrosse, C.; Haltiwanger, R. C. *Synlett* **1999**, *10*, 1612–1614.
53. (a) Clark, W. C.; Tickner-Eldridge, A. M.; Huang, G. K.; Pridgen, L. N.; Olsen, M. A.; Milss, R. J.; Lantos, I.; Baine, N. H. *J. Am. Chem. Soc.* **1998**, *120*, 4550. (b) Pridgen, L. N.; Huang, G. K. *Tetrahedron Lett.* **1998**, *39*, 8421.
54. Aggarwal, V. K.; Beffield, A. J. *Org. Lett.* **2003**, *5*, 5075–5078.
55. Browder, C. C.; West, F. G. *Synlett* **1999**, 1363–1366.
56. Giese, S.; Kastrup, L.; Stiens, D.; West, F. G. *Angew. Chem., Int. Ed.* **2000**, *39*, 1970–1973.
57. (a) Browder, C. C.; Marmsater, F. P.; West, F. G. *Org. Lett.* **2001**, *3*, 3033–3035. (b) Browder, C. C.; Marmsater, F. P.; West, F. G. *Can. J. Chem.* **2004**, *82*, 375–385.
58. Bender, J. A.; Arif, A. M.; West, F. G. *J. Am. Chem. Soc.* **1999**, *121*, 7443–7444.
59. Wang, Y.; Arif, A. M.; West, F. G. *J. Am. Chem. Soc.* **1999**, *121*, 876–877.
60. Wang, Y.; Schill, B. D.; Arif, A. M.; West, F. G. *Org. Lett.* **2003**, *5*, 2747–2750.
61. (a) Giese, S.; West, F. G. *Tetrahedron Lett.* **1998**, *39*, 8393–8396. (b) Giese, S.; West, F. G. *Tetrahedron* **2000**, *56*, 10221–10228.
62. de Lera, A. R.; Rey, J. G.; Hrovat, D.; Iglesias, B.; Lopez, S. *Tetrahedron Lett.* **1997**, *38*, 7425–7428.
63. Nair, V.; Bindu, S.; Sreekumar, V.; Chiaroni, A. *Org. Lett.* **2002**, *4*, 2821–2823.
64. Harding, K. E.; Clement, K. S.; Tseng, C. Y. *J. Org. Chem.* **1990**, *55*, 4403–4410.
65. Tius, M. A.; Drake, D. J. *Tetrahedron* **1996**, *52*, 14651–14660.
66. Tius, M. A.; Hu, H.; Kawakami, J. K.; Busch-Petersen, J. *J. Org. Chem.* **1998**, *63*, 5971–5976.
67. Tius, M. A.; Busch-Petersen, J.; Yamashita, M. *Tetrahedron Lett.* **1998**, *39*, 4219–4222.
68. Brady, S. F.; Singh, M. P.; Janso, J. E.; Clardy, J. *J. Am. Chem. Soc.* **2000**, *122*, 2116–2117.
69. Lin, S.; Dudley, G. B.; Tan, D. S.; Danishefsky, S. J. *Angew. Chem. Int. Ed.* **2002**, *41*, 2188–2191.
70. Nakazaki, A.; Sharma, U.; Tius, M. A. *Org. Lett.* **2002**, *4*, 3363–3366.
71. For an alternative Nazarov cyclization strategy targeting the hydroazulene, see Chiu, P.; Li, S. *Org. Lett.* **2004**, *6*, 613–616.
72. Srikrishna, A.; Dethe, D. H. *Org. Lett.* **2003**, *5*, 2295–2298.
73. Eaton, P. E.; Carlson, G. R.; Lee, J. T. *J. Org. Chem.* **1973**, *38*, 4071–4071.
74. For a collection of related examples and a detailed explanation of this form of the Nazarov cyclization, see Ref. **2a**.
75. Crisp, G. T.; Scott, W. J.; Stille, J. K. *J. Am. Chem. Soc.* **1984**, *106*, 7500–7506.
76. Neumann, M. F.; Miesch, M.; Lacroix, E. *Tetrahedron Lett.* **1989**, *30*, 3533–3536.
77. Leclerc, E.; Tius, M. A. Unpublished results.
78. He, W.; Frontier, A. J. Unpublished results.
79. Liang, G.; Trauner, D. *J. Am. Chem. Soc.* **2004**, *126*, 9544–9545.

**Biographical sketch**

**Alison J. Frontier** attended Harvard University, where she worked in the laboratory of Professor Yoshito Kishi. In 1992 she graduated with an AB in chemistry and became a research scientist at Merck Research Laboratories in Rahway, New Jersey, in the Basic Medicinal Chemistry division. She enrolled in the doctoral program at Columbia University in September 1994, conducted graduate work under the direction of Professor Samuel Danishefsky, and received her Ph.D. in June 1999. She was an NIH postdoctoral fellow at Stanford in the laboratory of Professor Barry Trost until January 2002, when she started her independent career as Assistant Professor of Chemistry at the University of Rochester.



**Christina Goudreau Collison** was born and raised in Manchester, NH. She attended Colby College where she began doing research for a senior project under the mentorship of Bradford Mundy. Upon receiving her B.A. in chemistry, she immediately began graduate study at the University of Rochester studying natural product synthesis with Robert Boeckman, Jr., and earning a Ph.D. in organic chemistry in 2004. She acquired a lectureship at Rochester Institute of Technology in the fall of 2003 and was appointed Assistant Professor of Chemistry in 2004. Professor Collison's research group currently supports two masters students and two undergraduate students and her research interests include heterocyclic chemistry, organometallic chemistry, and natural product synthesis.

# Synthesis of mono- and polyhydroxylated cyclobutane nucleoside analogs

Yoann Marsac,<sup>a</sup> Arnaud Nourry,<sup>a</sup> Stéphanie Legoupy,<sup>a,\*</sup> Muriel Pipelier,<sup>b</sup> Didier Dubreuil,<sup>b</sup> Anne-Marie Aubertin,<sup>c</sup> Nathalie Bourgougnon,<sup>d</sup> Rachid Benhida<sup>e</sup> and François Huet<sup>a,\*</sup>

<sup>a</sup>Laboratoire de Synthèse Organique, UCO2M, UMR CNRS 6011, Faculté des Sciences et Techniques, Université du Maine, Avenue Olivier Messiaen, F-72085 Le Mans cedex 9, France

<sup>b</sup>Laboratoire de Synthèse Organique, UMR CNRS 6513, FR CNRS 2465, Faculté des Sciences et Techniques, 2 rue de la Houssinière, BP 92208, F-44322 Nantes cedex 03, France

<sup>c</sup>Faculté de Médecine, Institut de Virologie, INSERM U 544, Université Louis Pasteur, 3 rue Koeberlé, F-67000 Strasbourg, France

<sup>d</sup>Laboratoire de Biologie et Chimie Moléculaire, Centre de recherche et d'enseignement Yves Coppens, Campus de Tohannic, BP 573, F-56017 Vannes, France

<sup>e</sup>Laboratoire de Chimie Bioorganique, UMR CNRS 6001, Université de Nice-Sophia Antipolis, Parc Valrose, F-06108 Nice cedex 2, France

Received 26 April 2005; revised 27 May 2005; accepted 31 May 2005

Available online 17 June 2005

**Abstract**—Enantiomerically enriched cyclobutene compounds **13** and **24** are good precursors of several cyclobutane nucleoside analogs. The synthetic ways involve, in the key step, either hydroboration or dihydroxylation.

© 2005 Elsevier Ltd. All rights reserved.

## 1. Introduction

Several nucleoside analogs have interesting biological activities and may act as antiviral or anticancer agents. Among them, oxetanocin **1**,<sup>1</sup> and its carbocyclic analogs **2** cyclobut-A and cyclobut-G,<sup>2</sup> are important examples of dihydroxylated four membered ring compounds of this family. Another carbocyclic analog, carbovir **3**,<sup>3</sup> and its prodrug abacavir **4**,<sup>4</sup> showed antiviral properties. In previous works, we prepared cyclobutene analogs of carbovir **5**,<sup>5</sup> then compounds **6** with a methylene spacer between the carbocycle and the base. We then envisioned, using the carbon–carbon double bond of an intermediate of synthesis of compounds **6**, or a related product, to prepare dihydroxylated nucleoside analogs **A** and **B**, via an hydroboration step. On the other hand, a dihydroxylation step would lead to trihydroxylated products **C** and **D** (Fig. 1).

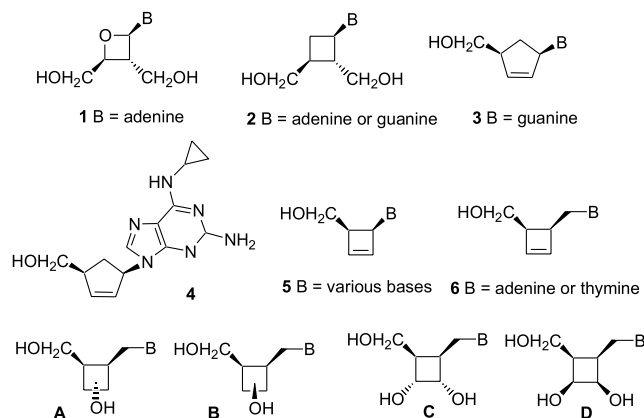


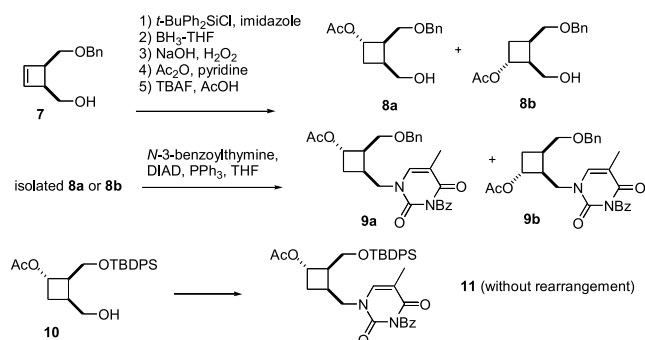
Figure 1.

## 2. Results and discussion

In a first approach in racemic series,<sup>7</sup> we carried out a Mitsunobu reaction with the benzylated compounds **8a** or **8b** and *N*-3-benzoylthymine (Scheme 1). However, an unexpected migration of the benzyloxy groups occurred and a mixture of the two regioisomers **9a** and **9b** was obtained. Fortunately, the migration did not occur starting from a

**Keywords:** Nucleoside analogs; Mitsunobu reaction; Hydroboration; Dihydroxylation.

\* Corresponding authors. Tel.: +33 2 43 83 33 38; fax: +33 2 43 83 39 02; e-mail addresses: slegoupy@univ-lemans.fr; fhuet@univ-lemans.fr



Scheme 1.

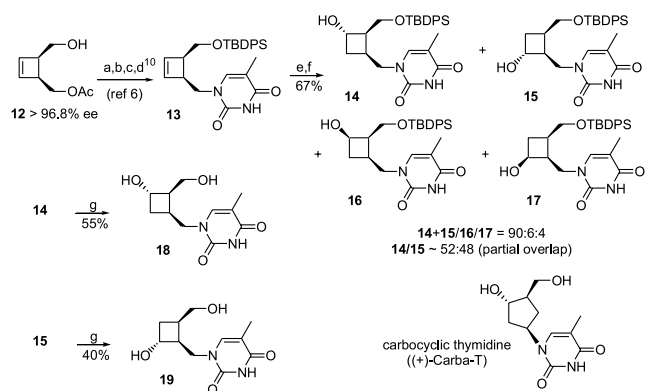
silylated compound **10**, which only led to the product of direct substitution **11**.

We then used this protecting group for the synthesis of the enantiomerically enriched compounds (Scheme 2). The starting material was the monoacetate **12**, which is available in high enantiomeric excess by an enzymatic acylation.<sup>8</sup> In this approach, the base coupling was envisioned before the addition step.



Scheme 2.

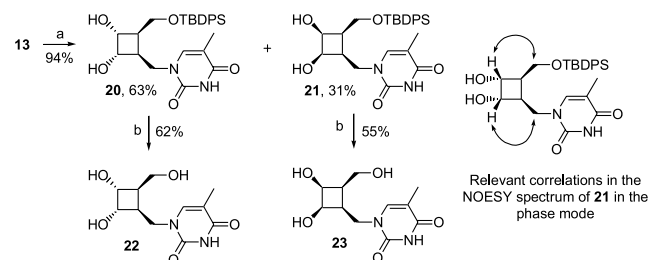
Compound **13**, previously described,<sup>6</sup> was subjected to hydroboration, which provided a mixture of the four expected products **14–17** (Scheme 3). These compounds were identified by NMR experiments including HMBC spectra to assign position of secondary OH groups.<sup>7</sup> Deprotection of **14** and **15** by a treatment with HF–pyridine provided the target molecules **18** and **19**, respectively. Compound **18** is a cyclobutane analog of carbocyclic thymidine, (+)-Carba-T,<sup>9</sup> which proved to be effective against HSV-1 and HSV-2, whereas the (–)-isomer was inactive.



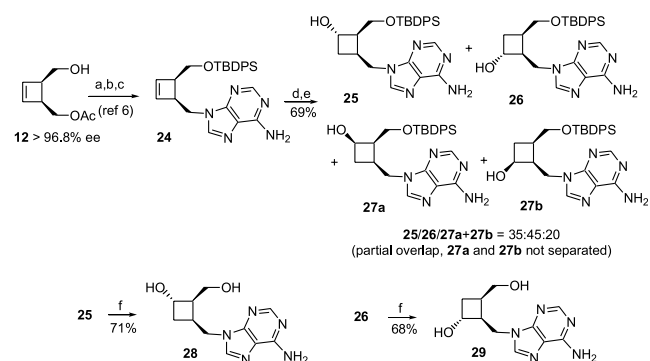
Scheme 3. (a) *t*BuPh<sub>2</sub>SiCl/imidazole/DMF; (b) NH<sub>3</sub>/MeOH; (c) PPh<sub>3</sub>/DEAD/*N*-3-benzoylthymine; (d) NaOH<sup>10</sup>; (e) BH<sub>3</sub>·THF; (f) H<sub>2</sub>O<sub>2</sub>/NaOH; (g) HF–pyridine.

Dihydroxylation of cyclobutene compound **13** by reaction with *N*-methylmorpholine *N*-oxide in the presence of osmium tetroxide as catalyst<sup>11</sup> yielded a mixture of compounds **20** and **21**, which were separated (Scheme 4).

Isomer **20** was assigned thanks to the NOESY spectrum in the phase mode showing correlations between <sup>1</sup>H near of OH and <sup>1</sup>H of the vicinal CH<sub>2</sub>. Desilylation of **20** and **21** gave the two trihydroxylated nucleosides, **22** and **23**, respectively.

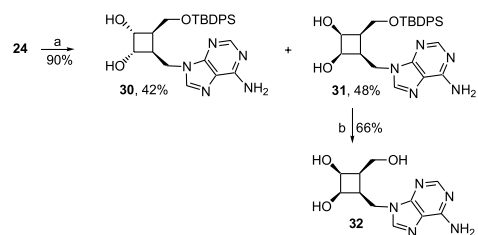
Scheme 4. (a) OsO<sub>4</sub>, NMO, THF/H<sub>2</sub>O; (b) HF–pyridine.

Hydroboration of compound **24**<sup>6</sup> provided a mixture of **25**, **26**, **27a** and **27b** (Scheme 5). The *trans*-isomers **25** and **26** were separated and equally identified thanks to NMR experiments, whereas the *cis*-isomers **27a** and **27b** could not be separated. Finally, desilylation of **25** and **26** provided nucleosides **28** and **29**, respectively.



Scheme 5. (a) *t*BuPh<sub>2</sub>SiCl/imidazole/DMF; (b) NH<sub>3</sub>/MeOH; (c) PPh<sub>3</sub>/DEAD/adenine/THF; (d) BH<sub>3</sub>·THF; (e) H<sub>2</sub>O<sub>2</sub>/NaOH; (f) HF–pyridine.

Dihydroxylation of **24** yielded a mixture of **30** and **31** (Scheme 6). Compound **31** was desilylated to lead to another trihydroxylated nucleoside **32**. In contrast, the same reaction failed from **30** probably due to its insolubility in CH<sub>2</sub>Cl<sub>2</sub>.

Scheme 6. (a) OsO<sub>4</sub>, NMO, THF/H<sub>2</sub>O; (b) HF–pyridine.

Several of these new products were subjected to biological evaluation. Compounds **19**, **22**, **23**, **28–30** and **32** did not show significant activity against HSV-1 and HIV-1. Compounds **19** and **22** showed neither cytotoxicity (KB cells) nor significant inhibition of acetylcholine esterase.

### 3. Conclusion

In conclusion, we prepared four dihydroxylated (**18**, **19**, **28**, **29**), and three trihydroxylated (**22**, **23**, **32**) new cyclobutane nucleosides as well as eight monohydroxylated (**14**–**17**, **25**, **26**, **27a** + **27b**) and four dihydroxylated (**20**, **21**, **30**, **31**) monosilylated precursors. We think that, it should be worth incorporating several of them in oligonucleotidic short sequences to test the biological properties. This following part of our research program is in progress.

### 4. Experimental

#### 4.1. General

NMR spectra were recorded on a Bruker AC 400 spectrometer at 400 and 100.6 MHz, for  $^1\text{H}$  and  $^{13}\text{C}$ , respectively. All melting points are uncorrected. Elemental analyses were performed by the service of microanalyses, CNRS, ICSN, Gif sur Yvette. High resolution mass spectra were recorded on a ZabSpec TOF Micromass spectrometer at the CRMPO, Rennes. Infrared spectra were measured with a FT infrared spectrometer Genesis Matteson instrument.

**4.1.1. (+)-N1-[(1S,2R,3S)-2-(tert-Butyl-diphenyl-silyloxymethyl)-3-hydroxy-cyclobutyl]methyl-5-methyl-1H,3H-pyrimidine-2,4-dione, 14; (–)-N1-[(1S,2R,4R)-2-(tert-butyl-diphenyl-silyloxymethyl)-4-hydroxy-cyclobutyl]methyl-5-methyl-1H,3H-pyrimidine-2,4-dione, 15; (+)-N1-[(1S,2R,3R)-2-(tert-butyl-diphenyl-silyloxymethyl)-3-hydroxy-cyclobutyl]methyl-5-methyl-1H,3H-pyrimidine-2,4-dione, 16; (+)-N1-[(1S,2R,4S)-2-(tert-butyl-diphenyl-silyloxymethyl)-4-hydroxy-cyclobutyl]methyl-5-methyl-1H,3H-pyrimidine-2,4-dione, 17.** A 1 M solution of  $\text{BH}_3 \cdot \text{THF}$  (2.3 mL, 2.3 mmol) in dry THF (4.5 mL) was added dropwise at 0 °C under argon and with stirring to a solution of **13**<sup>6</sup> (0.800 g, 1.74 mmol), obtained from a sample of **12**<sup>8</sup> of >96.8% ee, in dry THF (3.5 mL). The reaction mixture was stirred for 3 h at room temperature then 3 M NaOH (770  $\mu\text{L}$ , 2.3 mmol) and then 30–35%  $\text{H}_2\text{O}_2$  (250  $\mu\text{L}$ , ~2.3 mmol) were added at 0 °C. The reaction mixture was stirred for 1 h at room temperature. Evaporation, extraction of the resulting aqueous phase with  $\text{Et}_2\text{O}$  (4  $\times$  15 mL), washing of the combined organic phases with brine (20 mL), drying ( $\text{MgSO}_4$ ), evaporation then column chromatography on silica gel (cyclohexane/ $\text{EtOAc}$ : 3:1  $\rightarrow$  3:2) successively led to **17** (23 mg, 0.048 mmol, 4%), **16** (32 mg, 0.067 mmol, 6%), **14** (218 mg, 0.877 mmol), **14** + **15** (99 mg, 0.207 mmol) then **15** (184 mg, 0.384 mmol), yields of **14** and **15** ~30 and 27%, respectively. Data for **14**: white solid, mp 101.5–102.7 °C;  $[\alpha]_{\text{D}}^{20} +116$  (c 2.100,  $\text{CHCl}_3$ );  $^1\text{H}$  NMR ( $\text{CDCl}_3$ )  $\delta$  9.57 (br s, 1H), 7.68–7.63 (m, 4H), 7.45–7.37 (m, 6H), 6.91 (d, 1H,  $J=1.2$  Hz), 4.32 (ddd, 1H,  $J=7.4$ , 7.4, 7.4 Hz), 4.02 (dd, 1H,  $J=13.8$ , 11.3 Hz), 3.84 (dd, 1H,  $J=11.3$ , 4.9 Hz), 3.78 (dd, 1H,  $J=11.3$ , 6.9 Hz), 3.75 (dd, 1H,  $J=13.8$ , 4.9 Hz), 3.65–3.61 (m, 1H), 2.68–2.58 (m, 1H), 2.57–2.50 (m, 1H), 2.13 (ddd, 1H,  $J=11.3$ , 7.4, 2.9 Hz), 1.92–1.82 (m, 4H), 1.07 (s, 9H);  $^{13}\text{C}$  NMR ( $\text{CDCl}_3$ )  $\delta$  164.4, 151.3, 140.2, 135.5 (4C), 133.2 (2C), 129.9 (2C), 127.8 (4C), 110.7, 66.7, 61.8, 49.0, 48.7, 32.7, 28.9, 27.0 (3C), 19.2, 12.3; IR ( $\nu$   $\text{cm}^{-1}$ ) 3412 (br), 3195 (br),

3048, 2930–2856, 1677, 1469–1426, 1363, 1255, 1109, 1059, 822, 739–703. Anal. Calcd for  $\text{C}_{27}\text{H}_{34}\text{N}_2\text{O}_4\text{Si} \cdot 0.4\text{H}_2\text{O}$ : C, 66.75; H, 7.22; N, 5.77. Found: C, 66.56; H, 7.06; N, 5.64. Data for **15**: white solid, mp 62.1–64.3 °C;  $[\alpha]_{\text{D}}^{20} -54$  (c 1.895,  $\text{CHCl}_3$ );  $^1\text{H}$  NMR ( $\text{CDCl}_3$ )  $\delta$  10.1 (br s, 1H), 7.67–7.64 (m, 4H), 7.46–7.37 (m, 6H), 6.97 (m, 1H), 4.37 (ddd, 1H,  $J=7.9$ , 7.9, 7.9 Hz), 4.15 (dd, 1H,  $J=14.3$ , 9.8 Hz), 3.80 (dd, 1H,  $J=14.3$ , 4.4 Hz), 3.78 (dd, 1H,  $J=10.8$ , 7.4 Hz), 3.71 (dd, 1H,  $J=10.8$ , 4.4 Hz), 3.66–3.62 (m, 1H), 2.67–2.59 (m, 1H), 2.47–2.37 (m, 1H), 2.05–1.91 (m, 2H), 1.81 (d, 3H,  $J=1.2$  Hz), 1.08 (s, 9H);  $^{13}\text{C}$  NMR ( $\text{CDCl}_3$ )  $\delta$  163.8, 150.9, 140.1, 134.6 (4C), 132.1 (2C), 128.8 (2C), 126.8 (4C), 109.8, 69.1, 63.3, 48.3, 45.9, 30.8, 30.1, 25.9 (3C), 18.2, 11.2; IR ( $\nu$   $\text{cm}^{-1}$ ) 3404 (br), 3208 (br), 3049, 2932–2857, 1682, 1361, 1259–1224, 1111, 1075, 823, 740–702; HRMS calcd for  $\text{C}_{27}\text{H}_{34}\text{N}_2\text{O}_4\text{SiNa}$   $[\text{M}+\text{Na}]^+$ : 501.2186. Found: 501.2194. Data for **16**: colorless oil;  $[\alpha]_{\text{D}}^{20} +362$  (c 2.105,  $\text{CHCl}_3$ );  $^1\text{H}$  NMR ( $\text{CDCl}_3$ )  $\delta$  9.09 (br s, 1H, N–H); 7.71–7.66 (m, 4H), 7.49–7.39 (m, 6H), 6.68 (d, 1H,  $J=1.2$  Hz), 4.36–4.29 (m, 1H), 4.12 (dd, 1H,  $J=11.3$ , 5.9 Hz), 4.05 (dd, 1H,  $J=11.3$ , 5.4 Hz), 3.82 (dd, 1H,  $J=13.8$ , 5.9 Hz), 3.70 (dd, 1H,  $J=13.8$ , 9.3 Hz), 2.94 (d, 1H,  $J=7.4$  Hz), 2.77–2.69 (m, 1H), 2.52–2.44 (m, 1H), 2.43–2.33 (m, 1H), 2.05–1.98 (m, 1H), 1.81 (d, 3H,  $J=1.2$  Hz), 1.11 (s, 9H);  $^{13}\text{C}$  NMR ( $\text{CDCl}_3$ )  $\delta$  164.2, 150.8, 140.3, 135.6 (4C), 132.4 (2C), 130.1 (2C), 127.8 (4C), 110.3, 65.5, 61.1, 49.7, 44.5, 36.9, 28.3, 27.0, (3C), 19.1, 12.3; IR ( $\nu$   $\text{cm}^{-1}$ ) 3428, 3068–3048, 2929–2856, 1681, 1363, 1252–1223, 1109, 1074, 741–704; HRMS calcd for  $\text{C}_{27}\text{H}_{34}\text{N}_2\text{O}_4\text{NaSi}$   $[\text{M}+\text{Na}]^+$ : 501.2186. Found: 501.2186. Data for **17**: colorless oil;  $[\alpha]_{\text{D}}^{20} +179$  (c 1.390,  $\text{CHCl}_3$ );  $^1\text{H}$  NMR ( $\text{CDCl}_3$ )  $\delta$  9.08 (br s, 1H), 7.66 (dd, 4H,  $J=7.8$ , 1.5 Hz), 7.48–7.38 (m, 6H), 7.13 (d, 1H,  $J=1.2$  Hz), 4.25–4.20 (m, 1H), 4.19 (dd, 1H,  $J=14.3$ , 11.3 Hz), 4.08 (m, 1H), 3.89 (dd, 1H,  $J=14.3$ , 3.0 Hz), 3.85 (dd,  $J=11.3$ , 6.9 Hz), 3.75 (dd, 1H,  $J=11.3$ , 3.9 Hz), 2.87–2.78 (m, 1H), 2.55–2.46 (m, 1H), 2.44–2.37 (m, 1H), 1.91 (d, 3H,  $J=1.2$  Hz), 1.72 (ddd, 1H,  $J=12.8$ , 5.4, 4.2 Hz), 1.11 (s, 9H);  $^{13}\text{C}$  NMR ( $\text{CDCl}_3$ )  $\delta$  164.2, 151.5, 141.2, 135.5 (4C), 132.8 (2C), 130.0 (2C), 127.8 (4C), 111.0, 66.7, 64.2, 44.5, 42.4, 34.9, 31.6, 26.9 (3C), 19.2, 12.3; IR ( $\nu$   $\text{cm}^{-1}$ ) 3427, 3060, 2957–2857, 1673, 1368, 1243–1219, 1112, 1079, 737–702.

**4.1.2. (+)-N1-[(1S,2R,3S)-2-Hydroxymethyl-3-hydroxy-cyclobutyl]methyl-5-methyl-1H,3H-pyrimidine-2,4-dione, 18.** A solution of 65–70% HF–pyridine (9  $\mu\text{L}$ ) was added to a cooled solution (0 °C) of **14** (40 mg, 0.084 mmol) in  $\text{CH}_2\text{Cl}_2$  (0.6 mL). The reaction mixture was stirred for one night at room temperature then a small amount of  $\text{NaHCO}_3$  was added. After 30 min more of stirring, evaporation then column chromatography on silica gel ( $\text{CH}_2\text{Cl}_2/\text{MeOH}$ : 95:5) provided **18** (11 mg, 0.046 mmol, 55%) as a white solid, mp  $\leq 25$  °C;  $[\alpha]_{\text{D}}^{20} +529$  (c 1.295,  $\text{MeOH}$ );  $^1\text{H}$  NMR ( $\text{CD}_3\text{OD}$ )  $\delta$  7.45 (d, 1H,  $J=0.8$  Hz), 4.16 (ddd, 1H,  $J=7.4$ , 7.4, 7.4 Hz), 3.93 (dd, 1H,  $J=13.6$ , 10.6 Hz), 3.88 (dd, 1H,  $J=13.6$ , 6.0 Hz), 3.72 (dd, 1H,  $J=11.0$ , 6.0 Hz), 3.67 (dd, 1H,  $J=11.0$ , 8.0 Hz), 2.70–2.60 (m, 1H), 2.53–2.45 (m, 1H), 2.11 (ddd, 1H,  $J=11.2$ , 7.4, 2.4 Hz), 1.86 (m, 4H);  $^{13}\text{C}$  NMR ( $\text{CD}_3\text{OD}$ )  $\delta$  168.5, 154.9, 144.7, 112.7, 69.4, 62.4, 51.8, 51.1, 34.7, 31.2, 13.8; IR ( $\nu$   $\text{cm}^{-1}$ ) 3402, 2935, 2500, 1681, 1375, 1257, 1084, 772; HRMS calcd for  $\text{C}_{11}\text{H}_{16}\text{N}_2\text{O}_4\text{Na}$   $[\text{M}+\text{Na}]^+$ : 263.1008. Found: 263.1002.



**4.1.3. (+)-N1-[(1S,2R,4R)-2-Hydroxy-4-hydroxymethyl-cyclobutyl]methyl-5-methyl-1H,3H-pyrimidine-2,4-dione, 19.** Desilylation of **15** (40 mg, 0.084 mmol) (see preparation of **18**) followed by column chromatography on silica gel (CH<sub>2</sub>Cl<sub>2</sub>/MeOH: 95:5) provided **19** (8 mg, 0.033 mmol, 40%) as a white solid, mp 186.3–187.0 °C; [ $\alpha$ ]<sub>D</sub><sup>20</sup> +106 (c 0.960, MeOH); <sup>1</sup>H NMR (DMSO-*d*<sub>6</sub>)  $\delta$  7.53 (d, 1H, *J*=1.0 Hz), 4.92 (d, 1H, *J*=7.4 Hz), 4.61 (dd, 1H, *J*=5.3, 4.7 Hz), 3.99 (ddd, 1H, *J*=7.6, 7.6, 7.6 Hz), 3.78–3.71 (m, 2H), 3.57–3.41 (m, 2H), 2.47–2.39 (m, 1H), 2.20–2.12 (m, 1H), 1.88 (ddd, 1H, *J*=10.3, 7.6, 2.0 Hz), 1.74–1.66 (m, 4H); <sup>13</sup>C NMR (DMSO-*d*<sub>6</sub>)  $\delta$  168.4, 155.0, 141.7, 112.7, 68.2, 61.4, 46.7, 45.9, 32.5, 30.5, 12.2; IR ( $\nu$  cm<sup>-1</sup>) 3488, 3044–2940, 1670, 1464–1422, 1338, 1220, 1080, 756; HRMS calcd for C<sub>11</sub>H<sub>16</sub>N<sub>2</sub>O<sub>4</sub>Na [M+Na]<sup>+</sup>: 263.1008. Found: 263.1006.

**4.1.4. (-)-N1-[(1S,2S,3R,4R)-2,3-Dihydroxy-4-(*tert*-butyl-diphenyl-silyloxymethyl)-cyclobutyl]methyl-5-methyl-1H,3H-pyrimidine-2,4-dione, 20; (+)-N1-[(1S,2R,3S,4R)-2,3-dihydroxy-4-(*tert*-butyl-diphenyl-silyloxymethyl)-cyclobutyl]methyl-5-methyl-1H,3H-pyrimidine-2,4-dione, 21.** 4-Methylmorpholine *N*-oxide (390 mg, 3.320 mmol) and a 4% aqueous solution of OsO<sub>4</sub> (140  $\mu$ L, 5.6 mg, 0.022 mmol) were added to a solution of **13** (500 mg, 1.085 mmol) in a THF/H<sub>2</sub>O (10:1) mixture (5 mL). The reaction mixture was stirred for 2 h at 30 °C. Cooling, treatment with a 20% aqueous solution of NaHSO<sub>3</sub> (3 mL), evaporation, dilution with brine (5 mL), extraction with EtOAc (5  $\times$  15 mL), drying of the organic phases (Na<sub>2</sub>SO<sub>4</sub>), evaporation then column chromatography on silica gel (cyclohexane/EtOAc: 2:1  $\rightarrow$  1:5) successively led to **21** (168 mg, 0.340 mmol, 31%), then to **20** (336 mg, 0.680 mmol, 63%). Data for **20**: white solid, mp 155.8–156.6 °C; [ $\alpha$ ]<sub>D</sub><sup>20</sup> -8 (c 1.707, CHCl<sub>3</sub>); <sup>1</sup>H NMR (CDCl<sub>3</sub>)  $\delta$  9.96 (br s), 7.66–7.63 (m, 4H), 7.46–7.37 (m, 6H), 6.89 (d, 1H, *J*=1.4 Hz), 4.39 (dd, 1H, *J*=6.4, 6.4 Hz), 4.31–4.29 (m, 1H), 4.20 (dd, 1H, *J*=14.3, 10.3 Hz), 4.19–4.18 (m, 1H), 3.81 (dd, 1H, *J*=10.8, 6.4 Hz), 3.73 (dd, 1H, *J*=10.8, 4.2 Hz), 3.71 (dd, 1H, *J*=14.3, 4.7 Hz), 3.28 (d, 1H, *J*=3.9 Hz), 2.87–2.79 (m, 1H), 2.40–2.35 (m, 1H), 1.81 (d, 3H, *J*=1.4 Hz), 1.08 (s, 9H); <sup>13</sup>C NMR (CDCl<sub>3</sub>)  $\delta$  164.6, 151.8, 140.9, 135.6 (4C), 132.9, 132.7, 129.9 (2C), 127.9 (4C), 111.0, 70.2, 70.1, 61.9, 48.9, 44.5, 42.6, 26.9 (3C), 19.1, 12.3; IR ( $\nu$  cm<sup>-1</sup>) 3395, 3069, 2930, 2858, 1682, 1427, 1386, 1361, 1220, 1143, 1111, 1005, 908, 822, 735–702; HRMS calcd for C<sub>27</sub>H<sub>34</sub>N<sub>2</sub>O<sub>5</sub>NaSi [M+Na]<sup>+</sup>: 517.2134. Found: 517.2135. Data for **21**: white solid, mp 66.8 °C; [ $\alpha$ ]<sub>D</sub><sup>20</sup> +415 (c 1.625, CHCl<sub>3</sub>); <sup>1</sup>H NMR (CDCl<sub>3</sub>)  $\delta$  8.92 (br s), 7.69–7.65 (m, 4H), 7.48–7.38 (m, 6H), 7.11 (d, 1H, *J*=1.5 Hz), 4.39 (d, 1H, *J*=4.4 Hz), 4.34–4.29 (m, 1H), 4.26 (m, 1H), 4.07–3.99 (m, 3H), 3.83 (dd, 1H, *J*=14.3, 3.4 Hz), 3.05 (d, 1H, *J*=6.4 Hz), 2.84–2.75 (m, 1H), 2.51–2.44 (m, 1H), 1.91 (d, 3H, *J*=1.5 Hz), 1.09 (s, 9H); <sup>13</sup>C NMR (CDCl<sub>3</sub>)  $\delta$  163.8, 151.3, 140.9, 135.5 (4C), 132.6, 132.5, 130.0 (2C), 127.9 (4C), 111.2, 69.6, 66.4, 61.6, 44.1, 43.5, 36.9, 26.9 (3C), 19.1, 12.3; IR ( $\nu$  cm<sup>-1</sup>) 3403, 3192, 3070–3048, 2930, 2893–2857, 1678, 1427, 1385, 1365, 1247, 1217, 1158, 1111, 1008, 909, 823, 734–703; HRMS calcd for C<sub>27</sub>H<sub>34</sub>N<sub>2</sub>O<sub>5</sub>NaSi [M+Na]<sup>+</sup>: 517.2134. Found: 517.2130. Anal. Calcd for C<sub>27</sub>H<sub>34</sub>N<sub>2</sub>O<sub>5</sub>Si·0.6H<sub>2</sub>O: C, 64.16; H, 7.02; N, 5.54. Found: C, 64.07; H, 6.81; N, 5.46.

**4.1.5. (+)-N1-[(1S,2S,3R,4R)-2,3-Dihydroxy-4-hydroxymethyl]cyclobutyl]methyl-5-methyl-1H,3H-pyrimidine-2,4-dione, 22.** Desilylation of **20** (11 mg, 0.063 mmol) (see preparation of **18**) followed by column chromatography on silica gel (EtOAc  $\rightarrow$  EtOAc/MeOH: 8:2) provided **22** (11 mg, 0.043 mmol, 68%) as a white solid, mp 197.2–198.9 °C; [ $\alpha$ ]<sub>D</sub><sup>20</sup> +266 (c 1.450, DMSO); <sup>1</sup>H NMR (DMSO-*d*<sub>6</sub>)  $\delta$  11.15 (br s, 1H), 7.52 (d, 1H, *J*=1.0 Hz), 4.71 (d, 1H, *J*=4.0 Hz), 4.67 (d, 1H, *J*=5.9 Hz), 4.59–4.56 (m, 1H), 3.90–3.83 (m, 2H), 3.74 (d, 2H, *J*=8.4 Hz), 3.51–3.44 (m, 2H), 2.55–2.48 (m, 1H), 2.17–2.10 (m, 1H), 1.72 (d, 3H, *J*=1.0 Hz); <sup>13</sup>C NMR (DMSO-*d*<sub>6</sub>)  $\delta$  164.3, 151.0, 141.7, 108.1, 69.5, 68.9, 59.2, 46.5, 43.3, 42.2, 12.0; IR ( $\nu$  cm<sup>-1</sup>) 3324, 3186, 2950, 1669, 1478, 1417, 1365, 1217, 1156, 1021, 874; HRMS calcd for C<sub>11</sub>H<sub>16</sub>N<sub>2</sub>O<sub>5</sub>Na [M+Na]<sup>+</sup>: 279.0957. Found: 279.0961.

**4.1.6. (+)-N1-[(1S,2R,3S,4R)-2,3-Dihydroxy-4-hydroxymethyl]cyclobutyl]methyl-5-methyl-1H,3H-pyrimidine-2,4-dione, 23.** Desilylation of **21** (56 mg, 0.113 mmol) (see preparation of **18**) followed by column chromatography on silica gel (CH<sub>2</sub>Cl<sub>2</sub>/MeOH: 95:5  $\rightarrow$  9:1) provided **23** (16 mg, 0.033 mmol, 40%) as a white solid, mp 53.7–54.1 °C; [ $\alpha$ ]<sub>D</sub><sup>20</sup> +824 (c 2.850, MeOH); <sup>1</sup>H NMR (CD<sub>3</sub>OD)  $\delta$  7.53 (d, 1H, *J*=1.0 Hz), 4.31–4.27 (m, 1H), 4.25–4.22 (m, 1H), 4.10–3.95 (m, 2H), 3.91–3.88 (m, 2H), 2.67–2.59 (m, 2H), 1.85 (d, 3H, *J*=1.0 Hz); <sup>13</sup>C NMR (CD<sub>3</sub>OD)  $\delta$  167.1, 153.4, 144.2, 110.9, 71.1, 68.8, 59.6, 45.6, 44.3, 38.5, 12.4; IR ( $\nu$  cm<sup>-1</sup>) 3381, 3226, 2938, 1671, 1423, 1335, 1222, 1149; HRMS calcd for C<sub>11</sub>H<sub>16</sub>N<sub>2</sub>O<sub>5</sub>Na [M+Na]<sup>+</sup>: 279.0957. Found: 279.0957.

**4.1.7. (+)-N9-[(1S,2R,3S)-2-(*tert*-Butyl-diphenyl-silyloxymethyl)-3-hydroxy-cyclobutyl]methyl-9H-purin-6-amine, 25; (-)-N9-[(1S,2R,4R)-2-(*tert*-butyl-diphenyl-silyloxymethyl)-4-hydroxy-cyclobutyl]methyl-9H-purin-6-amine, 26 and *cis*-isomers, 27a and 27b.** Hydroboration of **24** (750.9 mg, 1.6 mmol) (see preparation of **14–17**) followed by column chromatography on silica gel (EtOAc) successively provided a mixture of **27a** and **27b** (65.5 mg, 0.134 mmol), a mixture of **27a**, **27b** and **25** (72.1 mg, 0.148 mmol), **25** (176.8 mg, 0.362 mg), a mixture of **25** and **26** (21.9 mg, 0.045 mmol) then **26** (201.6 mg, 0.413 mmol), yields of **27a** + **27b**, **25**, **26**  $\sim$  14, 24 and 31%, respectively. Data for **25**: white solid, mp 93.5–95.3 °C; [ $\alpha$ ]<sub>D</sub><sup>20</sup> +218 (c 2.025, CH<sub>2</sub>Cl<sub>2</sub>); <sup>1</sup>H NMR (CDCl<sub>3</sub>)  $\delta$  8.34 (s, 1H), 7.75 (s, 1H), 7.68–7.65 (m, 4H), 7.47–7.38 (m, 6H), 5.63 (br s, 2H), 4.45–4.39 (m, 2H), 4.29 (dd, 1H, *J*=13.8, 10.8 Hz), 3.88 (dd, 1H, *J*=11.2, 5.2 Hz), 3.83 (dd, 1H, *J*=11.2, 6.4 Hz), 2.94–2.84 (m, 1H), 2.58–2.51 (m, 1H), 2.13 (ddd, 1H, *J*=11.7, 8.4, 2.9 Hz), 1.90 (ddd, 1H, *J*=11.7, 8.7, 7.4 Hz), 1.08 (s, 9H); <sup>13</sup>C NMR (CDCl<sub>3</sub>)  $\delta$  155.4, 152.8, 150.1, 140.1, 135.6 (2C), 135.5 (2C), 133.4, 133.2, 129.9 (2C), 127.8 (4C), 119.4, 66.8, 61.8, 60.4, 48.8, 45.3, 33.3, 26.9 (3C), 19.2; IR ( $\nu$  cm<sup>-1</sup>) 3330–3185, 2930–2857, 1709–1597, 1472–1415, 1361, 1220, 1106, 1059, 823, 740–698; HRMS calcd for C<sub>27</sub>H<sub>34</sub>N<sub>5</sub>O<sub>2</sub>Si [M+H]<sup>+</sup>: 488.2482. Found: 488.2453. Data for **26**: white solid, mp 75.5–76.7 °C; [ $\alpha$ ]<sub>D</sub><sup>20</sup> -19 (c 1.705, CH<sub>2</sub>Cl<sub>2</sub>); <sup>1</sup>H NMR (CDCl<sub>3</sub>)  $\delta$  8.28 (s, 1H), 7.70–7.67 (m, 4H), 7.65 (s, 1H), 7.48–7.38 (m, 6H), 5.85 (br s, 2H), 4.51 (ddd, 1H, *J*=8.0, 8.0, 8.0 Hz), 4.47 (dd, 1H, *J*=14.3, 4.4 Hz), 4.37 (dd, 1H, *J*=14.3, 9.5 Hz), 3.86 (dd, 1H, *J*=10.8, 6.9 Hz), 3.81 (dd, 1H, *J*=10.8, 4.9 Hz), 2.83–2.75 (m, 1H), 2.55–2.47 (m, 1H), 2.15 (ddd,

1H,  $J=11.3, 8.0, 2.5$  Hz), 1.90 (ddd, 1H,  $J=11.3, 9.8, 8.0$  Hz), 1.11 (s, 9H);  $^{13}\text{C}$  NMR ( $\text{CDCl}_3$ )  $\delta$  155.4, 152.6, 149.7, 140.3, 135.7–135.6 (4C), 133.3–133.2 (2C), 129.9 (2C), 127.8 (4C), 119.3, 69.7, 64.2, 47.5, 44.7, 31.5, 31.2, 27.0 (3C) 19.2; IR ( $\nu$   $\text{cm}^{-1}$ ) 3329, 2932–2858, 1709–1599, 1473–1417, 1361, 1221, 1105, 1074, 823, 741–701; HRMS calcd for  $\text{C}_{27}\text{H}_{34}\text{N}_5\text{O}_2\text{Si}$   $[\text{M}+\text{H}]^+$ : 488.2482. Found: 488.2470.

**4.1.8. (+)-N9-[(1S,2R,3S)-2-Hydroxymethyl-3-hydroxy-cyclobutyl]methyl-9H-purin-6-amine, 28.** Desilylation of **25** (36.8 mg, 0.076 mmol) (see preparation of **18**) followed by column chromatography on silica gel (EtOAc/MeOH: 5:1) provided **28** (13.3 mg, 0.053 mmol; 71%) as a white solid, mp 97.5–98.7 °C;  $[\alpha]_{\text{D}}^{20} +461$  ( $c$  0.750, MeOH);  $^1\text{H}$  NMR ( $\text{DMSO}-d_6$ )  $\delta$  8.14 (s, 1H), 8.12 (s, 1H), 7.17 (br s, 2H), 5.04 (d, 1H,  $J=5.9$  Hz), 4.59 (br s, 1H), 4.33 (dd, 1H,  $J=13.8, 5.4$  Hz), 4.19 (dd, 1H,  $J=13.8, 11.3$  Hz), 4.12–4.05 (m, 1H), 3.57–3.52 (m, 2H), 2.74–2.64 (m, 1H), 2.38–2.31 (m, 1H), 1.91 (ddd, 1H,  $J=10.8, 7.4, 2.5$  Hz), 1.63 (ddd, 1H,  $J=10.8, 9.2, 8.2$  Hz);  $^{13}\text{C}$  NMR ( $\text{DMSO}-d_6$ )  $\delta$  155.4, 152.5, 150.1, 141.1, 119.5, 65.8, 52.2, 49.2, 44.4, 32.9, 29.1; IR ( $\nu$   $\text{cm}^{-1}$ ) 3274, 2938, 1643, 1483–1420, 1365, 1217, 1081, 1007; HRMS calcd for  $\text{C}_{11}\text{H}_{16}\text{N}_5\text{O}_2$   $[\text{M}+\text{H}]^+$ : 250.1304. Found: 250.1304.

**4.1.9. (–)-N9-[(1S,2R,4R)-2-Hydroxymethyl-3-hydroxy-cyclobutyl]methyl-9H-purin-6-amine, 29.** Desilylation of **26** (51.8 mg, 0.106 mmol) (see preparation of **18**) followed by column chromatography on silica gel (EtOAc/MeOH: 9:1) provided **29** (17.9 mg, 0.072 mmol, 68%) as a white solid, mp 233.8–235.7 °C;  $[\alpha]_{\text{D}}^{20} -122$  ( $c$  0.900, DMSO);  $^1\text{H}$  NMR ( $\text{DMSO}-d_6$ )  $\delta$  8.36 (s, 1H), 8.09 (s, 1H), 7.26 (br s, 2H), 5.11 (br s, 1H), 4.87 (br s, 1H), 4.37 (dd, 1H,  $J=14.0, 7.8$  Hz), 4.19 (dd, 1H, 14.0, 7.4 Hz), 4.04 (ddd, 1H,  $J=7.4, 7.4, 7.4$  Hz), 3.55 (dd, 1H,  $J=10.8, 7.9$  Hz), 3.45 (dd, 1H,  $J=10.8, 5.9$  Hz), 2.64–2.57 (m, 1H), 2.17–2.09 (m, 1H), 1.86 (ddd, 1H,  $J=9.8, 7.4, 1.4$  Hz), 1.63 (m, 1H);  $^{13}\text{C}$  NMR ( $\text{DMSO}-d_6$ )  $\delta$  155.9, 152.2, 149.5, 140.9, 118.7, 68.3, 61.3, 46.7, 42.5, 32.4, 30.5; IR ( $\nu$   $\text{cm}^{-1}$ ) 3114, 2942, 1703, 1615, 1481–1422, 1371–1300, 1215, 1075, 1038; HRMS calcd for  $\text{C}_{11}\text{H}_{16}\text{N}_5\text{O}_2$   $[\text{M}+\text{H}]^+$ : 250.1304. Found: 250.1303.

**4.1.10. (+)-N9-[(1S,2S,3R,4R)-2,3-Dihydroxy-4-(tert-butyl-diphenyl-silyloxymethyl)cyclobutyl]methyl-9H-purin-6-amine, 30; (+)-N9-[(1S,2R,3S,4R)-2,3-dihydroxy-4-(tert-butyl-diphenyl-silyloxymethyl)cyclobutyl]methyl-9H-purin-6-amine, 31.** Dihydroxylation of **24** (512 mg, 1.090 mmol) (see preparation of **20+21**) followed by column chromatography on silica gel (EtOAc/MeOH, 99:1→90:10) successively led to **31** (263 mg, 0.522 mmol, 48%) then to **30** (231 mg, 0.459 mg, 42%). Data for **30**: white solid, mp 203.2–204.7 °C;  $[\alpha]_{\text{D}}^{20} +62$  ( $c$  1.520, DMSO);  $^1\text{H}$  NMR ( $\text{DMSO}-d_6$ )  $\delta$  8.14 (s, 1H), 8.08 (s, 1H), 7.62 (dd, 4H,  $J=7.4, 1.5$  Hz), 7.48–7.40 (m, 6H), 7.20 (br s, 2H), 4.88 (d, 1H,  $J=5.4$  Hz), 4.81 (d, 1H,  $J=6.4$  Hz), 4.37 (dd,  $J=13.8, 6.7$  Hz), 4.31 (dd, 1H,  $J=13.8, 9.4$  Hz), 4.07–3.98 (m, 2H), 3.84 (dd, 1H,  $J=10.8, 6.9$  Hz), 3.79 (dd, 1H,  $J=10.8, 5.1$  Hz), 2.87–2.80 (m, 1H), 2.40–2.33 (m, 1H), 1.00 (s, 9H);  $^{13}\text{C}$  NMR ( $\text{DMSO}-d_6$ )  $\delta$  156.0, 152.4, 149.7, 140.6, 135.2 (4C), 133.0 (2C), 129.9 (2C), 128.0 (4C), 118.9, 69.9, 68.7, 62.1, 43.5, 42.9, 42.6, 26.8, (3C) 18.9; IR ( $\nu$   $\text{cm}^{-1}$ ) 3319, 2853, 1650–

1600, 1361, 1258, 1150, 1088, 1042, 880, 739–701. Anal. Calcd for  $\text{C}_{27}\text{H}_{33}\text{N}_5\text{O}_3\text{Si} \cdot 0.6\text{H}_2\text{O}$ : C, 63.03; H, 6.70; N, 13.61. Found: C, 63.01; H, 6.63; N, 13.56. Data for **31**: white solid, mp 74.1–75.3 °C;  $[\alpha]_{\text{D}}^{20} +200$  ( $c$  1.160,  $\text{CHCl}_3$ );  $^1\text{H}$  NMR ( $\text{CDCl}_3$ )  $\delta$  8.27 (s, 1H), 7.74 (s, 1H), 7.70–7.66 (m, 4H), 7.45–7.35 (m, 6H), 6.40 (br s, 2H), 4.60 (dd, 1H,  $J=14.5, 11.5$  Hz), 4.31 (dd, 1H,  $J=14.5, 3.2$  Hz), 4.32–4.27 (m, 2H), 4.23–4.20 (m, 1H), 4.10 (dd, 1H,  $J=10.8, 5.1$  Hz), 2.91–2.83 (m, 1H), 2.49–2.42 (m, 1H), 1.08 (s, 9H);  $^{13}\text{C}$  NMR ( $\text{CDCl}_3$ )  $\delta$  155.8, 152.3, 149.2, 141.0, 135.5 (4C), 132.2 (2C), 129.8 (2C), 127.8 (4C), 119.5, 69.7, 66.0, 61.9, 44.4, 40.0, 38.5, 26.9 (3C), 19.1; IR ( $\nu$   $\text{cm}^{-1}$ ) 3453, 2956–2864, 1650–1621, 1338–1328, 1256, 1169, 1095, 827, 744–707; HRMS calcd for  $\text{C}_{27}\text{H}_{33}\text{N}_5\text{O}_3\text{NaSi}$   $[\text{M}+\text{Na}]^+$ : 526.2250. Found: 526.2250.

**4.1.11. (+)-N9-[(1S,2R,3S,4R)-2,3-Dihydroxy-4-hydroxy-methylcyclobutyl]methyl-9H-purin-6-amine, 32.** Desilylation of **31** (59.3 mg, 0.117 mmol) (see preparation of **18**) followed by column chromatography on silica gel (EtOAc/MeOH: 6:1) provided **32** (20.7 mg, 0.078 mmol, 66%) as a white solid, mp 188.6–191.3 °C;  $[\alpha]_{\text{D}}^{20} +438$  ( $c$  1.415, DMSO);  $^1\text{H}$  NMR ( $\text{CD}_3\text{OD}$ )  $\delta$  8.19 (s, 1H), 8.16 (s, 1H), 4.61 (dd, 1H,  $J=14.3, 10.8$  Hz), 4.45 (dd, 1H,  $J=14.3, 4.7$  Hz), 4.34–4.31 (m, 1H), 4.24–4.20 (m, 1H), 4.02–3.89 (m, 2H), 2.82–2.75 (m, 1H), 2.71–2.65 (m, 1H);  $^{13}\text{C}$  NMR ( $\text{CD}_3\text{OD}$ )  $\delta$  159.0, 155.2, 152.2, 145.1, 121.7, 72.4, 70.5, 61.2, 45.7, 42.7, 41.2; IR ( $\nu$   $\text{cm}^{-1}$ ) 3152, 2936, 1737, 1642–1601, 1478, 1365, 1230–1217, 1155, 1019; HRMS calcd for  $\text{C}_{11}\text{H}_{15}\text{N}_5\text{O}_3\text{Na}$   $[\text{M}+\text{Na}]^+$ : 288.1073. Found: 288.1071.

## Acknowledgements

We thank the local section of Sarthe of the Ligue Nationale contre le cancer for a fellowship to Y. M. and French Government and Région des Pays de la Loire for financial support (CER chimie fine).

## References and notes

- Shimada, N.; Hasegawa, S.; Harada, T.; Tomisawa, T.; Fujii, A.; Takita, T. *J. Antibiot.* **1986**, *39*, 1623–1625. Nakamura, H.; Hasegawa, S.; Shimada, N.; Fujii, A.; Takita, T.; Iitaka, Y. *J. Antibiot.* **1986**, *39*, 1626–1629. Hoshino, H.; Shimizu, N.; Shimada, N.; Takita, T.; Takeuchi, T. *J. Antibiot.* **1987**, *40*, 1077–1078.
- Hayashi, S.; Norbeck, D. W.; Rosenbrook, W.; Fine, R. L.; Matsukura, M.; Plattner, J. J.; Broder, S. B.; Mitsuya, H. *Antimicrob. Agents Chemother.* **1990**, *34*, 287–294.
- Coates, J. A. V.; Inggall, H. J.; Pearson, B. A.; Penn, C. R.; Storer, R.; Williamson, C.; Cameron, J. M. *Antiviral Res.* **1991**, *15*, 161–168.
- Hugues, W.; McDowell, J. A.; Shenep, J.; Flynn, P.; Kline, M. W.; Yogev, R.; Symonds, W.; Lou, H.; Hetherington, S. *Antimicrob. Agents Chemother.* **1999**, *43*, 609–615.
- Gourdel, M.-E.; Huet, F. *J. Org. Chem.* **1997**, *62*, 2166–2172. Gourdel-Martin, M.-E.; Huet, F. *Nucleosides Nucleotides* **1999**, *18*, 645–648.

6. Hubert, C.; Alexandre, C.; Aubertin, A.-M.; Huet, F. *Tetrahedron* **2002**, *58*, 3775–3778.
7. Marsac, Y.; Nourry, A.; Legoupy, S.; Pipelier, M.; Dubreuil, D.; Huet, F. *Tetrahedron Lett.* **2004**, *45*, 6461–6463.
8. Pichon, C.; Hubert, C.; Alexandre, C.; Huet, F. *Tetrahedron: Asymmetry* **2000**, *11*, 2429–2434.
9. Béres, J.; Sági, G.; Tömöskozi, L.; Gruber, L.; Baitz-Gács, E.; Ötvös, L.; De Clercq, E. *J. Med. Chem.* **1990**, *33*, 1353–1360.
10. We observed, in the course of this work, that using 25% NH<sub>4</sub>OH (25 mL for 5.16 mmol of benzoyl derivative in MeOH solution (65 mL)) led to an increase of the yield with respect to reaction with NaOH. Compound **13** was thus, obtained in 93% (in 48 h at room temperature) instead of 85% (in 72 h at room temperature).
11. Wengel, J.; Svendsen, M. L.; Jørgensen, P. N.; Nielson, C. *Nucleosides Nucleotides* **1995**, *14*, 1465–1479.

# Thermal cyclization of *N*-[2-(2-propenyl)-1-naphthyl] ketenimines: intramolecular Diels–Alder reaction versus [1,5] hydrogen migration. Synthesis of dibenz[*b,h*]acridines and benzo[*h*]quinolines

Mateo Alajarín,\* Ángel Vidal\* and María-Mar Ortín

*Departamento de Química Orgánica, Facultad de Química, Universidad de Murcia, Campus de Espinardo, E-30100 Murcia, Spain*

Received 18 April 2005; revised 30 May 2005; accepted 31 May 2005

Available online 22 June 2005

Dedicated to Professor Joaquín Plumet on the occasion of his 60th birthday

**Abstract**—The thermal treatment of *N*-(2-propenyl)-1-naphthylamines provided the expected aza-Claisen rearranged products, 2-(2-propenyl)-1-naphthylamines and benz[*g*]indoles, these last derived from an intramolecular hydroamination reaction on those primary products. The 2-(2-propenyl)-1-naphthylamines were converted into their triphenylphosphazene derivatives, which by aza-Wittig reaction with disubstituted ketenes yielded *N*-[2-(2-propenyl)-1-naphthyl] ketenimines. The heating of these ketenimines in boiling toluene induced their cyclization either via an intramolecular Diels–Alder reaction, to afford dibenz[*b,h*]acridines, or via [1,5] hydrogen migration from the sp<sup>3</sup> carbon atom of the propenyl substituent to the central carbon atom of the ketenimine fragment, followed by a 6π electrocyclic ring closure, to give benzo[*h*]quinolines.

© 2005 Elsevier Ltd. All rights reserved.

## 1. Introduction

The Diels–Alder reaction is undoubtedly one of the most valuable reactions for the synthetic organic chemists due to its widespread utility and enormous synthetic potential.<sup>1</sup> This pericyclic process represents a powerful and effective methodology for the formation of carbon–carbon bonds, which allows high regio and stereoselective constructions of six-membered carbocyclic systems with up to four contiguous new stereogenic centers.<sup>2</sup> This reaction is of particular interest in the total synthesis of naturally occurring products,<sup>3</sup> or structurally related compounds.

The Diels–Alder strategy has likewise found application in the preparation of six-membered heterocyclic compounds by positioning heteroatoms at the diene or at the dienophile (hetero Diels–Alder reaction), and, in its intramolecular version, a heterocycle is also forged by locating a heteroatom in the tether connecting diene and dienophile.<sup>4</sup> On the other hand, the characterization of several natural

occurring potential Diels–Alderases established the Diels–Alder reaction as a viable biosynthetic transformation.<sup>5</sup>

In the context of the synthesis of heterocyclic compounds via Diels–Alder reactions, ketenimines [R<sup>1</sup>–N=C=CR<sup>2</sup>R<sup>3</sup>] are valuable precursors for the construction of six-membered heterocycles by means of inter or intramolecular variants of these reactions.<sup>6</sup> These heterocumulenes have the ability to act as 2-azadienes (R<sup>1</sup>=vinyl or aryl group) or as all-carbon dienes (R<sup>2</sup> and/or R<sup>3</sup>=vinyl or aryl group), an even can serve as the dienophile component, with either the N=C or the C=C bond of the ketenimine being involved in the cycloaddition process. As a matter of fact, as part of our research work directed towards the study of the participation of ketenimines in pericyclic processes, we have successfully applied the Diels–Alder strategy to the synthesis of benzo[*d,e*][1,6]naphthyridines<sup>7</sup> and pyrido[2,3,4-*d,e*]quinazolines<sup>7</sup> (ketenimines as 2-azadienes), benzimidazo[1,2-*b*]isoquinolines<sup>8</sup> and benz[*b*]acridines<sup>9</sup> (ketenimines as all-carbon dienes) and pyrido[1,2-*a*]benzimidazoles<sup>10</sup> (ketenimines as dienophiles by means of its C=C bond).

Our method for preparing benz[*b*]acridines<sup>9</sup> was based on a thermally induced intramolecular Diels–Alder reaction on

**Keywords:** Aza-Claisen; Hydroamination; Ketenimines; Diels–Alder; Hydrogen migration.

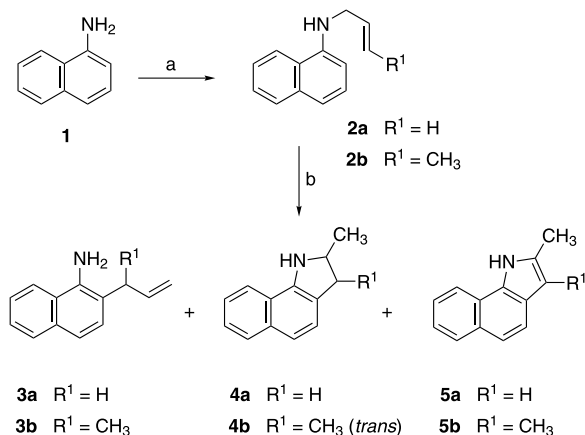
\* Corresponding authors. Tel.: +34 968 367497; fax: +34 968 364149 (M.A.); e-mail: alajarin@um.es

*N*-[2-(2-propenyl)phenyl]-*C,C*-diphenyl ketenimines, in which the ketenimine function acts as an all-carbon diene and the C=C bond of the 2-propenyl side-chain plays the role of the dienophile. With the aim of extending the versatility of this particular methodology we decided to try its application for the synthesis of dibenz[*b,h*]acridines,<sup>11</sup> by combination of a *C*-aryl ketenimine fragment (diene) and a 2-propenyl group (dienophile) at the adjacent C1 and C2 carbon atoms of a naphthalene ring. We present herein the results obtained in the thermally induced intramolecular cyclization of *N*-[2-(2-propenyl)-1-naphthyl] ketenimines, forming the expected Diels–Alder adducts, 7,7a,8,14-tetrahydrodibenz[*b,h*]acridines, unexpectedly accompanied by benzo[*h*]quinolines, whose formation should involve an initial [1,5] hydrogen migration from the sp<sup>3</sup> carbon atom of the propenyl substituent to the central carbon atom of the ketenimine function.

## 2. Results and discussion

### 2.1. Preparation of 2-(2-propenyl)-1-naphthylamines

The *N*-(2-propenyl)-1-naphthylamines **2a,b** were both prepared following the reaction conditions reported by Sloviter<sup>12</sup> for the preparation of **2a**, but with a new and simpler protocol that we have developed for the isolation and purification of these two compounds. The reaction of an excess of 1-naphthylamine **1** with 3-chloropropene and 1-chloro-2-butene, in refluxing ethanol for 5 h, yielded only the monoalkylation products **2a** (67% yield) and **2b** (84% yield), respectively. The thermal treatment of neat *N*-(2-propenyl)-1-naphthylamines **2** in a sealed tube at 260–270 °C for 3 h induced their aza-Claisen rearrangement providing 2-(2-propenyl)-1-naphthylamines **3** in approximately 50% yield, whereas a considerable amount (20–30%) of the starting material remained unaltered (Scheme 1). The transformations **2**→**3** were carried out under the reaction conditions described by Marcinkiewicz<sup>12b</sup> and Inada<sup>12c</sup> in their respective preparations of **3a** and **3a,b**, but we used a different method in the purification step. We purified the crude materials resulting from these thermal treatments by column chromatography, instead of by distillation or conversion of compounds **3** into their *N*-tosylamines as reported. With the objective of obtaining



**Scheme 1.** Reagents and conditions: (a)  $\text{CH}_2=\text{CHCH}_2\text{Cl}$  or  $\text{CH}_3-\text{CH}=\text{CH}-\text{CH}_2\text{Cl}$ , ethanol, reflux, 5 h; (b) 260–270 °C, sealed tube, 3–6 h.

a total conversion in the transformations **2**→**3** we increased the reaction time. Thus, when the *N*-(2-propenyl) derivative **2a** ( $R^1 = \text{H}$ ) was heated at 260–270 °C for 4 h it was totally consumed, and column chromatography of the reaction mixture allowed the isolation of 2-(2-propenyl)-1-naphthylamine **3a** ( $R^1 = \text{H}$ ; 38% yield), and, surprisingly, of 2-methyl-2,3-dihydro-1*H*-benz[*g*]indole **4a** ( $R^1 = \text{H}$ ; 35% yield) and 2-methyl-1*H*-benz[*g*]indole **5a** ( $R^1 = \text{H}$ ; 3% yield) (Scheme 1). A similar thermal treatment of **2b** ( $R^1 = \text{CH}_3$ ) for 6 h yielded only *trans*-2,3-dimethyl-2,3-dihydro-1*H*-benz[*g*]indole **4b** ( $R^1 = \text{CH}_3$ ; 22% yield) and 2,3-dimethyl-1*H*-benz[*g*]indole **5b** ( $R^1 = \text{CH}_3$ ; 21% yield) (Scheme 1).<sup>13</sup>

The analytical and spectral data of benz[*g*]indoles **4** and **5** are in accordance with the proposed structures. The *trans* relative positioning of the two methyl groups of **4b** was unequivocally determined by a NOESY experiment. Moreover, the collected data for benzindoles **5** are totally coincident with those previously reported for these compounds.<sup>14</sup>

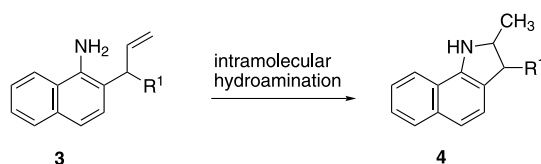
The formation of the 2,3-dihydro-1*H*-benz[*g*]indoles **4** could be explained as occurring by an intramolecular hydroamination reaction of the carbon–carbon double bond of the 2-propenyl substituent in amines **3** (Scheme 2). Further spontaneous dehydrogenation of **4** under the reaction conditions should give the aromatic derivatives **5**.

The intramolecular hydroamination of aminoalkenes is a well-known reaction, which is usually accomplished by mediation of alkali metals, transition-metals, and actinide and lanthanide complexes.<sup>15</sup> On the other hand, it has been reported that *N*-allylanilines undergo aromatic 3-aza-Cope rearrangement in the presence of HY-Zeolite, HEMT or HZeolite beta, in solution at 80 °C, to afford mixtures of *ortho*-allylanilines and indolines,<sup>16</sup> and in the presence of  $\text{Zn}^{+2}$  montmorillonite, under microwave irradiation in the absence of solvent, to yield indolines.<sup>17</sup> By contrast, the intramolecular hydroamination occurring in compounds **3** takes place under thermal conditions and in the absence of any catalyst.<sup>18</sup>

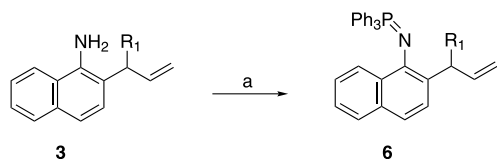
### 2.2. Thermal cyclization of *N*-[2-(2-propenyl)-1-naphthyl] ketenimines

Triphenylphosphazenes **6** were prepared by reaction of amines **3**, in acetonitrile solution, with triphenylphosphane, carbon tetrachloride and triethylamine (Scheme 3).

Treatment of a toluene solution of triphenylphosphazene **6a** ( $R^1 = \text{H}$ ) with diphenylketene at room temperature afforded *N*-[2-(2-propenyl)-1-naphthyl]-*C,C*-diphenylketenimine **7a**. The formation of ketenimine **7a** was established by IR spectroscopy: the IR spectrum of the reaction mixture



**Scheme 2.** Intramolecular hydroamination in the aminoalkenes **3**.

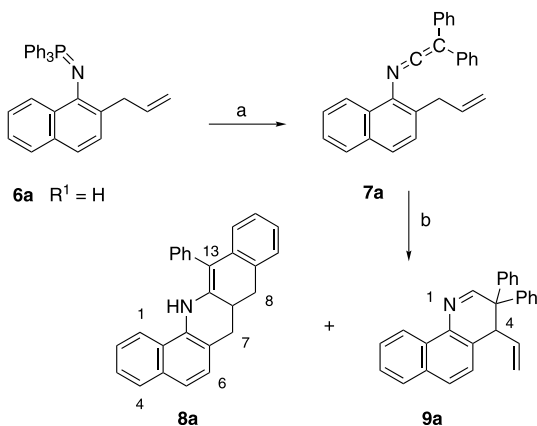


**Scheme 3.** Reagents and conditions: (a)  $\text{PPh}_3$ ,  $\text{CCl}_4$ ,  $\text{Et}_3\text{N}$ , acetonitrile, rt, 16 h.

showed a strong absorption at  $2004\text{ cm}^{-1}$ , characteristic of the  $\text{N}=\text{C}=\text{C}$  grouping. Next, the toluene solution containing ketenimine **7a** was heated under reflux up to the total disappearance of the cumulenic band in its IR spectrum, approximately 1 h. The crude material obtained from this thermal treatment was chromatographed, giving as result the isolation of the expected Diels–Alder cycloadduct 13-phenyl-7,7a,8,14-tetrahydrodibenz[*b,h*]acridine (**8a**), in 40% yield, along with a 37% of an unexpected reaction product which was identified as 3,3-diphenyl-4-vinyl-3,4-dihydrobenzo[*h*]quinoline (**9a**) (Scheme 4).

The analytical and spectral data of the dibenz[*b,h*]acridine **8a** are essentially similar to those of the benz[*b*]acridines previously prepared by us.<sup>9</sup> The IR spectrum of compound **8a** exhibits a strong absorption at  $3428\text{ cm}^{-1}$  due to the vibration of the amino group. In its  $^1\text{H}$  NMR spectrum the protons of the two methylene groups appear overlapped in a complex signal at  $\delta = 2.92\text{--}3.23\text{ ppm}$ . The proton  $\text{H-C7a}$  is observed as a multiplet, at  $\delta = 3.44\text{--}3.54\text{ ppm}$ . The  $^{13}\text{C}$  NMR spectrum of **8a** shows the signals corresponding to the  $\text{sp}^3$  hybridized carbon atoms at  $\delta = 33.4$ , 34.9 (C7a) and 36.0 ppm.

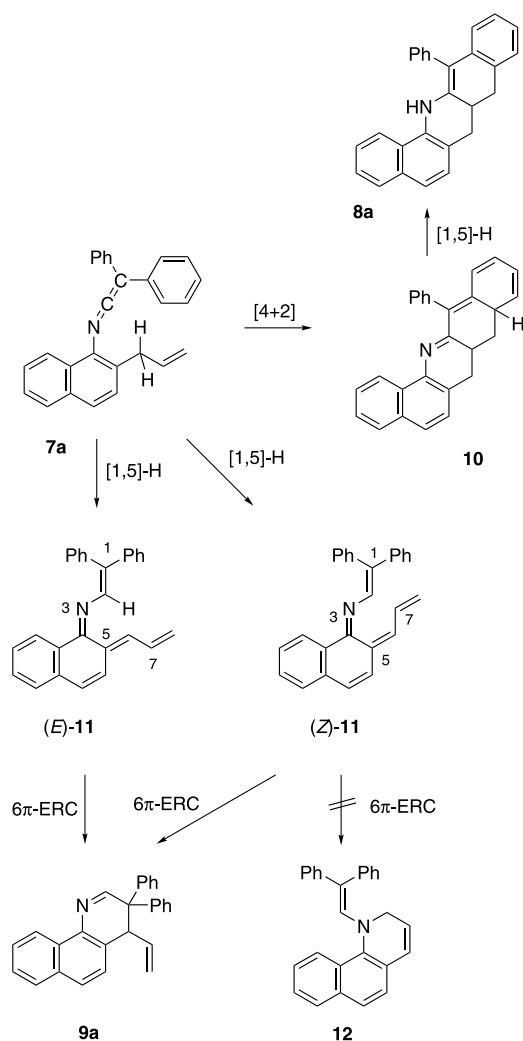
In the  $^1\text{H}$  NMR spectrum of the benzo[*h*]quinoline **9a** the vinyl substituent is clearly observed, its protons appearing at the following chemical shifts: 4.66 ( $\text{CH}=\text{CH}_\text{A}\text{H}_\text{B}$ ), 4.78 ( $\text{CH}=\text{CH}_\text{A}\text{H}_\text{B}$ ) and 5.54 ( $\text{CH}=\text{CH}_2$ ), all showing the expected multiplicities and coupling constants. In this spectrum, the proton  $\text{H-C2}$  appears at 8.71 ppm as a doublet, due to a small coupling constant ( $^4J = 1.2\text{ Hz}$ , W-type) with  $\text{H-C4}$ , as revealed by a COSY experiment. This last proton appears at  $\delta = 4.22\text{ ppm}$  as a broad doublet, as result of its coupling with the vinylic methine proton ( $^3J = 8.4\text{ Hz}$ ), with the two methylene protons ( $^4J = 1.0$ , 0.6 Hz, allylic-type) and with  $\text{H-C2}$ . The  $^{13}\text{C}$  NMR



**Scheme 4.** Reagents and conditions: (a)  $\text{Ph}_2\text{C}=\text{C}=\text{O}$ , toluene, rt, 10 min; (b) Toluene, reflux, 1 h.

spectrum of compound **9a** shows two signals in the aliphatic region: one at  $\delta = 49.9\text{ ppm}$  due to the methine carbon C4, and the other one at  $\delta = 52.3\text{ ppm}$  associated to the quaternary carbon atom C3. The methylene carbon of the vinyl group resonates at  $\delta = 116.9\text{ ppm}$ , and the signal of the iminic carbon C2 appears at  $\delta = 164.6\text{ ppm}$ .

The transformation of the *C,C*-diphenyl ketenimine **7a** into the tetrahydrodibenz[*b,h*]acridine **8a** can be explained by an intramolecular Diels–Alder reaction, the ketenimine fragment acting as all-carbon diene with the participation of its cumulated  $\text{C}=\text{C}$  bond, followed by hydrogen shift. On the other hand, we believe that the conversion of ketenimine **7a** into benzo[*h*]quinoline **9a** takes place by initial [1,5] migration of a hydrogen atom from the benzylic methylene to the central carbon atom of the ketenimine function. This sigmatropic rearrangement may lead to the stereoisomeric intermediates (*E*)-**11** and (*Z*)-**11**, in which the carbon–carbon double bond exocyclic to the naphthalene core is of *E* and *Z* configuration, respectively (Scheme 5). In these intermediates the atoms of the original ketenimine grouping and the 2-propenyl substituent now form part of a conjugated 3-aza-1,3,5,7-octatetraene system. The cyclization of intermediates (*E*)-**11** and (*Z*)-**11** via a  $6\pi$  electrocyclic ring closure ( $6\pi$ -ERC) involving the

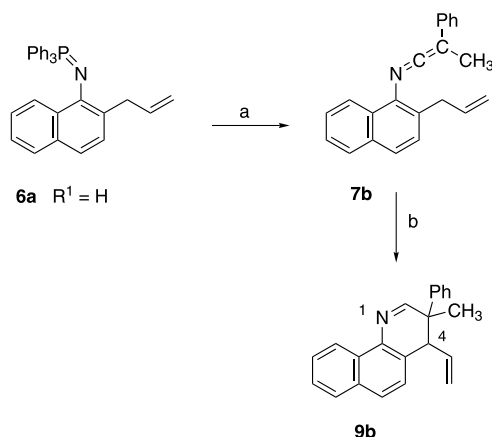


**Scheme 5.** Proposed mechanism for the conversion **7a** → **8a** + **9a**.

3-azatriene fragment<sup>19</sup> of the 3-aza-1,3,5,7-octatetraene system should provide the 3,4-dihydrobenzo[*h*]quinoline **9a**. Intermediate (*Z*)-**11** has also the appropriate geometry to undergo cyclization by means of an alternative  $6\pi$ -ERC mode, that involving the 1-azatriene fragment of the 3-aza-1,3,5,7-octatetraene system, affording the benzo[*h*]quinoline **12**. This is not the case, as this compound was not detected in the <sup>1</sup>H NMR spectrum of the crude material obtained from the thermal treatment of ketenimine **7a**, before the purification step.

Examples of sigmatropic [1,5]-H shifts to the electrophilic central carbon atom of ketenimines have been occasionally reported. Goerdeler<sup>20</sup> has described that *C*-imidoyl ketenimines underwent, at room temperature, [1,5] hydrogen migration followed by  $6\pi$ -ERC to yield dihydropyrimidines, whereas Foucaud<sup>21</sup> has demonstrated that, in refluxing dichloromethane, *N*-imidoyl ketenimines converted into pyrrolotriazines by [1,5]-H shift followed by intramolecular [4+2] cycloaddition. More recently, Wentrup<sup>22</sup> has reported that *N*-phenyl ketenimines bearing methyl groups at the *ortho* position to the nitrogen atom, under very mild flash vacuum thermolysis conditions (350 °C), suffer a facile [1,5] hydrogen migration and subsequent electrocyclization to dihydroquinolines.

The generation of *N*-[2-(2-propenyl)-1-naphthyl] ketenimines bearing one or two alkyl substituent at the terminal carbon atom of the ketenimine moiety instead of phenyl groups should, respectively, decrease or prevent the probability of occurring the [4+2] cyclization mode. Thus the evolution of such ketenimines via the sequence [1,5]-H/ $6\pi$ -ERC should be favoured. A major limitation that we found in the preparation of ketenimines by the aza-Wittig reaction of phosphazenes with ketenes is that only ketenes that are stable enough to be isolated under usual working conditions could be employed successfully.<sup>23</sup> Thus, we carried out the reaction of triphenylphosphazene **6a** ( $R^1 = H$ ), in toluene solution at room temperature, with the isolable methylphenylketene to generate the *C*-methyl-*C*-phenyl ketenimine **7b** (Scheme 6). When this ketenimine was heated in refluxing toluene it experienced cyclization to 3-methyl-3-phenyl-4-vinyl-3,4-dihydrobenzo[*h*]quinoline (**9b**), which was obtained as a 1:1 mixture of *cis* and *trans* diastereoisomers in good yield (73%).

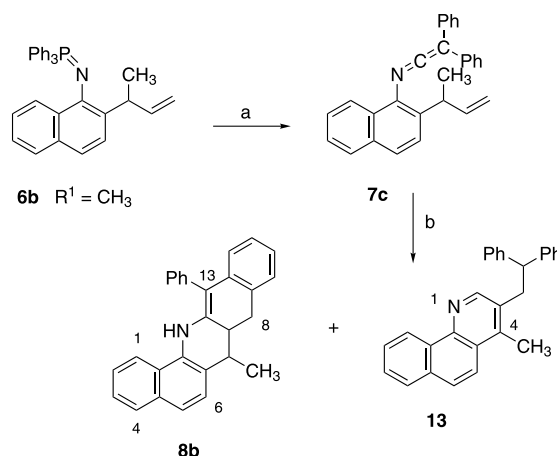


**Scheme 6.** Reagents and conditions: (a)  $\text{Ph}(\text{CH}_3)\text{C}=\text{C}=\text{O}$ , toluene, rt, 10 min; (b) Toluene, reflux, 1 h.

This result suggests that in *N*-[2-(2-propenyl)-1-naphthyl] ketenimines **7** the presence of one alkyl substituent at their terminal carbon atom is enough to bring about their cyclization periselectively via the consecutive [1,5] hydrogen migration/ $6\pi$  electrocyclic ring closure path.

Expecting a similar chemical behavior to that observed for the *C,C*-diphenyl ketenimine **7a** we prepared the methyl substituted analogue **7c** (Scheme 7), although it emerged not to be the case. The difference between these two ketenimines is the presence in **7c** of a methyl group at the  $\text{sp}^3$  carbon atom of the side chain. Two different fractions were collected when the crude material that resulted from the heating of ketenimine **7c** in toluene at reflux temperature for 1 h was chromatographed. The first one consisted on a 1:1 mixture of the two possible diastereoisomers of 7-methyl-13-phenyl-7,7a,8,14-tetrahydrodibenz[*b,h*]acridine (**8b**), along with a small amount of an unidentified impurity we were not able to separate chromatographically. Compound **8b** was separated from the impurity by crystallization from diethyl ether. This is the reason why pure **8b** was obtained in low yield (14%). The crystalline product still consisted on both diastereoisomers of **8b** in a 1:1 ratio. From the second chromatographic fraction 3-(2,2-diphenylethyl)-4-methylbenzo[*h*]quinoline (**13**) was isolated in 17% yield.

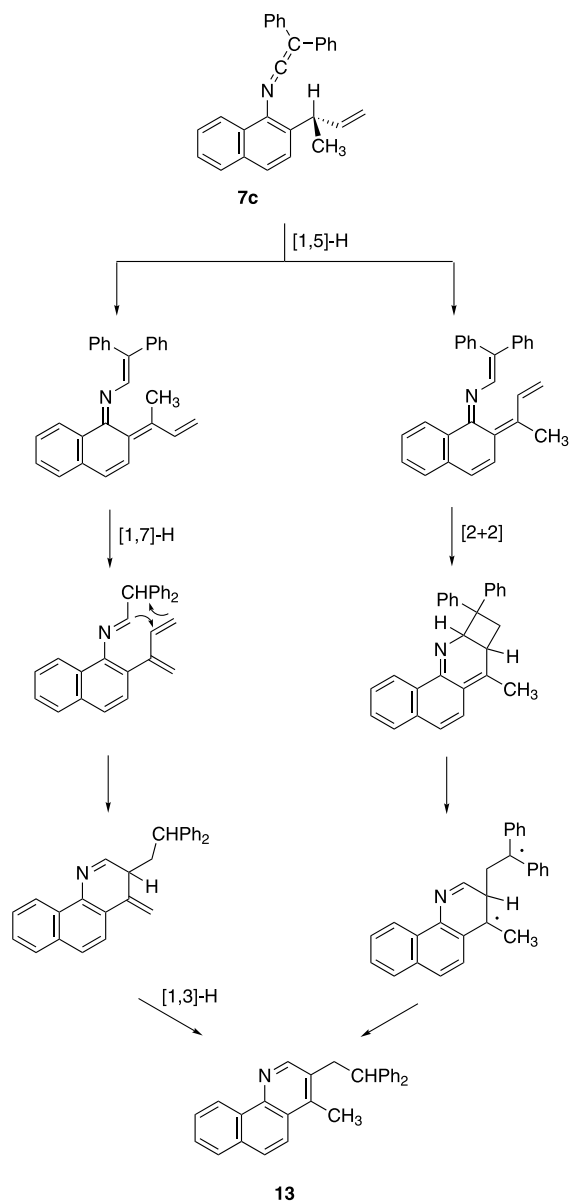
The structures of compounds **8b** and **13** were confirmed by their analytical and spectroscopic data. The main features of the <sup>1</sup>H NMR spectrum of benzo[*h*]quinoline **13** are the following: a singlet at  $\delta = 2.46$  ppm, associated with the methyl group  $\text{CH}_3\text{-C}4$ , a doublet and a triplet at  $\delta = 3.61$  ppm and  $\delta = 4.27$  ppm, respectively, assigned to the methylene and methine protons of the diphenylethyl substituent at C3, and a singlet at  $\delta = 8.49$  ppm attributed to the proton  $\text{H-C}2$ . The positions of the diphenylethyl and methyl substituents at the benzoquinoline ring were determined by performing NOESY and NOE difference experiments. These experiments associated the signals of the diphenylethyl group with those of  $\text{H-C}2$  and  $\text{CH}_3\text{-C}4$ .  $\text{H-C}2$  and  $\text{CH}_3\text{-C}4$ , in turn, did not show any effect on each other. Also NOE effect was observed between  $\text{H-C}5$  and the methyl group.



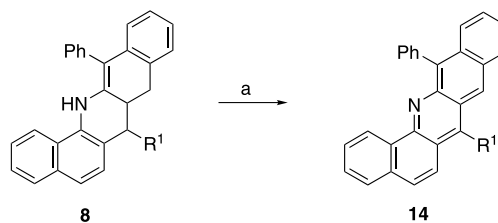
**Scheme 7.** Reagents and conditions: (a)  $\text{Ph}_2\text{C}=\text{C}=\text{O}$ , toluene, rt, 10 min; (b) Toluene, reflux, 1 h.

The formation of the dibenzacridine **8b** is easily understood as occurring by an intramolecular Diels–Alder reaction in ketenimine **7c**, whereas the formation of benzoquinoline **13** should occur by a new, more complex, mechanistic pathway. Probably, the conversion **7c** → **13** is initiated by an [1,5] hydrogen migration from the  $sp^3$  carbon of the propenyl substituent to the central carbon of the ketenimine function, as it could be ascertained by the presence of an hydrogen atom at carbon 2 of compound **13**. After this first hydrogen shift the resulting intermediate could undergo evolution to the benzoquinoline **13**, for example, either by means of a sequence of shifts or by a mechanistic pathway involving the formation of biradical species, as it is shown in Scheme 8.

The aza-Wittig reaction of triphenylphosphazene **6b** with methylphenylketene, and the subsequent thermal treatment of the resulting *C*-methyl-*C*-phenyl ketenimine only gave, in our hands, very complex reaction mixtures.



**Scheme 8.** Two mechanistic proposals for explaining the conversion of **7c** into **13**.



**Scheme 9.** Reagents and conditions: (a) Pd/C, *ortho*-xylene, reflux, 3 h.

### 2.3. Preparation of aromatic dibenz[*b,h*]acridines

Finally, the 7,7a,8,14-tetrahydrodibenz[*b,h*]acridines **8** could be easily oxidized in refluxing *ortho*-xylene in the presence of Pd/C to give the fully aromatic dibenz[*b,h*]acridines **14** (Scheme 9). Compounds **14** were thus obtained in almost quantitative yields (82–97%).

## 3. Conclusion

In summary, in this work we have reported that under thermal conditions, and in the absence of any catalyst, 2-(2-propenyl)-1-naphthylamines undergo a formal intramolecular hydroamination reaction to yield 2,3-dihydrobenz[*g*]indoles. We have also described how *N*-[2-(2-propenyl)-1-naphthyl] ketenimines undergo cyclization either by a Diels–Alder cycloaddition or by an [1,5] hydrogen migration followed by a  $6\pi$  electrocyclic ring closure, providing new routes to dibenz[*b,h*]acridines and benzo[*h*]quinolines. The mode selectivity, Diels–Alder cycloaddition versus [1,5] hydrogen migration, found in the cyclization of the *N*-[2-(2-propenyl)-1-naphthyl] ketenimines prepared depends basically on the nature of the substituents at the terminal carbon atom of the ketenimine function.

## 4. Experimental

### 4.1. General method

All mps were determined on a Kofler hot-plate mp apparatus and are uncorrected. IR spectra were obtained as films or Nujol emulsions on a Nicolet Impact 400 spectrophotometer. NMR spectra were recorded on a Bruker Avance 300 (300, 75 MHz for  $^1\text{H}$  and  $^{13}\text{C}$ , respectively) or a Bruker Avance 400 (400 and 100 MHz for  $^1\text{H}$  and  $^{13}\text{C}$ , respectively), in  $\text{CDCl}_3$  as solvent, and the chemical shifts are expressed in ppm relative to  $\text{Me}_4\text{Si}$  at  $\delta=0.00$  for  $^1\text{H}$  and to  $\text{CDCl}_3$  at  $\delta=77.1$  for  $^{13}\text{C}$ . Mass spectra were recorded on a Hewlett-Packard 5993C spectrometer or on a VG-Autospec spectrometer. Microanalyses were performed on a Carlo Erba EA-1108 instrument.

### 4.2. Materials

Diphenylketene<sup>24</sup> and methylphenylketene<sup>25</sup> were prepared according to literature procedures.



### 4.3. General procedure for the preparation of *N*-(2-propenyl)-1-naphthylamines **2**

1-Naphthylamine **1** (12.88 g, 90 mmol) was dissolved in ethanol (100 ml) and 3-chloropropene (2.29 g, 30 mmol) or 1-chloro-2-butene (2.71 g, 30 mmol) was added. The reaction mixture was heated at reflux temperature for 5 h. After cooling at room temperature, the solvent was removed under reduced pressure, and aqueous NaOH 5% (200 ml) was added to the solid residue. The resulting suspension was stirred at room temperature for 5 min, and then extracted with dichloromethane (2×75 ml). The combined organic layer was washed with water (100 ml) and dried over anhydrous MgSO<sub>4</sub>. The dichloromethane was removed under reduced pressure and the resulting material was purified by column chromatography [silica gel; hexanes/diethyl ether 9:1 (v/v)].

**4.3.1. *N*-(2-Propenyl)-1-naphthylamine<sup>12a</sup> (2a).** Yield 67%. <sup>1</sup>H NMR (CDCl<sub>3</sub>) δ = 3.92 (d, 2H, *J* = 5.2 Hz), 4.43 (br s, 1H), 5.18–5.24 (m, 1H), 5.29–5.40 (m, 1H), 5.96–6.16 (m, 1H), 6.65 (d, 1H, *J* = 7.4 Hz), 7.20–7.44 (m, 4H), 7.75–7.81 (m, 2H).

**4.3.2. (*E*)-*N*-(2-Butenyl)-1-naphthylamine<sup>12e</sup> (2b).** Yield 84%. <sup>1</sup>H NMR (CDCl<sub>3</sub>) δ = 1.78–1.83 (m, 3H), 3.88–3.90 (m, 2H), 4.38 (br s, 1H), 5.73–5.91 (m, 2H), 6.67 (dd, 1H, *J* = 7.5, 0.9 Hz), 7.28–7.31 (m, 1H), 7.37–7.52 (m, 3H), 7.81–7.86 (m, 2H).

### 4.4. Thermal treatment of *N*-(2-propenyl)-1-naphthylamine **2a**

*N*-(2-Propenyl)-1-naphthylamine **2a** (3.66 g, 20 mmol) was heated in a sealed tube at 260–270 °C for 4 h. After cooling at room temperature, the crude material was dissolved in dichloromethane (20 ml) and transferred to a round bottom flask. The solvent was removed under reduced pressure and the resulting oil was chromatographed on a silica gel column using hexanes/diethyl ether (4:1, v/v) as eluent. The fractions containing the major component were combined and the solvent removed under reduced pressure to give an oily residue which was subjected to a second column chromatography using dichloromethane/hexanes (9:1; v/v) as eluent.

**4.4.1. 2-(2-Propenyl)-1-naphthylamine<sup>12b</sup> (3a).** Yield 38%. <sup>1</sup>H NMR (CDCl<sub>3</sub>) δ = 3.47 (dt, 2H, *J* = 6.2, 1.7 Hz), 4.16 (br s, 2H), 5.09 (dq, 1H, *J* = 8.2, 1.7 Hz), 5.14–5.56 (m, 1H), 5.90–6.10 (m, 1H), 7.20 (d, 1H, *J* = 8.4 Hz), 7.29 (d, 1H, *J* = 8.4 Hz), 7.36–7.48 (m, 2H), 7.73–7.83 (m, 2H).

**4.4.2. 2-Methyl-2,3-dihydro-1*H*-benz[*g*]indole (4a).** Yield 35%; mp 76–77 °C; colorless prisms (*n*-hexane). <sup>1</sup>H NMR (CDCl<sub>3</sub>) δ = 1.34 (d, 3H, *J* = 6.3 Hz), 2.81 (dd, 1H, *J* = 15.3, 7.5 Hz), 3.32 (dd, 1H, *J* = 15.3, 9.0 Hz), 3.89 (br s, 1H), 4.10–4.18 (m, 1H), 7.26 (s, 2H), 7.31–7.38 (m, 2H), 7.55–7.59 (m, 1H), 7.74–7.79 (m, 1H). <sup>13</sup>C NMR (CDCl<sub>3</sub>) δ = 22.7, 38.6, 55.7, 118.7, 120.7 (s), 121.4, 122.5 (s), 123.6, 124.7, 125.0, 128.5, 133.5 (s), 146.3 (s). MS *m/z* (I%): 183 (M<sup>+</sup>, 63), 168 (100). IR (nujol)  $\nu$  cm<sup>-1</sup>: 3355, 1575, 1523, 1423, 1332, 1284, 1160, 1126, 1103, 1080, 880, 867, 803,

767, 749, 674. Anal. Calcd for C<sub>13</sub>H<sub>13</sub>N: C, 85.20; H, 7.15; N, 7.65. Found: C, 85.03; H, 7.18; N, 7.77.

**4.4.3. 2-Methyl-1*H*-benz[*g*]indole<sup>14a</sup> (5a).** Yield 3%. <sup>1</sup>H NMR (CDCl<sub>3</sub>) δ = 2.45 (d, 3H, *J* = 0.9 Hz), 6.32–6.34 (m, 1H), 7.36 (ddd, 1H, *J* = 8.1, 6.9, 1.3 Hz), 7.41–7.48 (m, 2H), 7.61 (dd, 1H, *J* = 8.6, 0.3 Hz), 7.80–7.83 (m, 1H), 7.86–7.89 (m, 1H), 8.45 (br s, 1H).

### 4.5. Thermal treatment of (*E*)-*N*-(2-butenyl)-1-naphthylamine **2b**

(*E*)-*N*-(2-Butenyl)-1-naphthylamine **2b** (3.94 g, 20 mmol) was heated in a sealed tube at 260–270 °C for 3 h. After cooling at room temperature, the crude material was dissolved in dichloromethane (20 ml) and transferred to a round bottom flask. The solvent was removed under reduced pressure and the resulting oil was chromatographed on a silica gel column using dichloromethane/hexanes (4:1, v/v) as eluent.

In this reaction a 25% of the starting material was recovered.

**4.5.1. 2-(1-Methyl-2-propenyl)-1-naphthylamine<sup>12c</sup> (3b)** Yield 54%. <sup>1</sup>H NMR (CDCl<sub>3</sub>) δ = 1.48 (d, 3H, *J* = 7.0 Hz), 3.64–3.72 (m, 1H), 4.24 (br s, 2H), 5.11 (dt, 1H, *J* = 6.2, 1.6 Hz), 5.14–5.15 (m, 1H), 5.99–6.07 (m, 1H), 7.28 (d, 1H, *J* = 8.5 Hz), 7.32 (d, 1H, *J* = 8.5 Hz), 7.38–7.46 (m, 2H), 7.75–7.81 (m, 2H).

When (*E*)-*N*-(2-butenyl)-1-naphthylamine **2b** was heated at 260–270 °C for 6 h the reaction products were *trans*-2,3-dimethyl-2,3-dihydro-1*H*-benz[*g*]indole **4b** and 2,3-dimethyl-1*H*-benz[*g*]indole **5b**.

**4.5.2. *trans*-2,3-Dimethyl-2,3-dihydro-1*H*-benz[*g*]indole (4b).** Yield 22%; dark oil. <sup>1</sup>H NMR (CDCl<sub>3</sub>) δ = 1.37 (d, 3H, *J* = 6.8 Hz), 1.41 (d, 3H, *J* = 6.2 Hz), 3.04 (dq, 1H, *J* = 8.7, 6.8 Hz), 3.64 (dq, 1H, *J* = 8.7, 6.2 Hz), 3.74 (br s, 1H), 7.23–7.31 (m, 2H), 7.35–7.45 (m, 2H), 7.60–7.63 (m, 1H), 7.75–7.81 (m, 1H). <sup>13</sup>C NMR (CDCl<sub>3</sub>) δ = 18.3, 21.1, 45.2, 64.5, 118.9, 120.7 (s), 121.5, 122.2, 124.7, 125.1, 127.9 (s), 128.5, 133.6 (s), 145.6 (s). MS *m/z* (I%): 197 (M<sup>+</sup>, 27), 194 (100). IR (nujol)  $\nu$  cm<sup>-1</sup>: 3368, 1574, 1519, 1453, 1441, 1420, 1375, 1335, 1267, 1257, 1082, 976, 937, 805, 777, 747, 678. Anal. Calcd for C<sub>14</sub>H<sub>15</sub>N: C, 85.24; H, 7.66; N, 7.10. Found: C, 85.05; H, 7.78; N, 7.16.

**4.5.3. 2,3-Dimethyl-1*H*-benz[*g*]indole<sup>14d</sup> (5b).** Yield 21%. <sup>1</sup>H NMR (CDCl<sub>3</sub>) δ = 2.28 (d, 3H, *J* = 0.5 Hz), 2.40 (s, 3H), 7.35 (ddd, 1H, *J* = 8.2, 6.9, 1.2 Hz), 7.45 (ddd, 1H, *J* = 8.2, 6.9, 1.2 Hz), 7.47 (d, 1H, *J* = 8.2 Hz), 7.59 (d, 1H, *J* = 8.6 Hz), 7.87 (t, 2H, *J* = 8.9 Hz), 8.32 (br s, 1H).

### 4.6. General procedure for the preparation of 2-(2-propenyl)-1-(triphenylphosphoranylidenamino)naphthalenes **6**

The corresponding 2-(2-propenyl)-1-naphthylamine **3** (10 mmol) and triphenylphosphane (5.24 g, 20 mmol) were dissolved in a mixture of anhydrous acetonitrile (25 ml) and triethylamine (15 ml). Then carbon tetrachloride was added (10 ml), and the reaction mixture was kept at

room temperature without stirring for 16 h. The precipitated solid was filtered and washed with anhydrous acetonitrile (2 × 2 ml). From the filtrate the solvent was removed under reduced pressure, and the crude material was purified by column chromatography using silica gel deactivated with triethylamine as solid phase and hexanes/diethyl ether (3:2, v/v) as eluent. After removing the solvent from the combined fractions containing **6** the resulting white solid was treated with diethyl ether (5 ml), filtered and dried.

**4.6.1. 2-(2-Propenyl)-1-(triphenylphosphoranylideneamino)naphthalene (6a).** Yield 49%; mp 131–132 °C; colorless prisms (diethyl ether/*n*-pentane). <sup>1</sup>H NMR (CDCl<sub>3</sub>) δ = 3.32 (ddd, 2H, *J* = 6.5, 3.1, 1.5 Hz), 4.78–4.86 (m, 2H), 5.59–5.69 (m, 1H), 6.97 (ddd, 1H, *J* = 8.1, 6.8, 1.0 Hz), 7.17–7.22 (m, 2H), 7.25 (dd, 1H, *J* = 8.3, 2.5 Hz), 7.35–7.40 (m, 6H), 7.45–7.50 (m, 3H), 7.58–7.65 (m, 7H), 7.99 (d, 1H, *J* = 8.3 Hz). <sup>13</sup>C NMR (CDCl<sub>3</sub>) δ = 37.1 (d, *J* = 1.3 Hz), 114.7, 118.9 (d, *J* = 3.6 Hz), 123.6, 124.2, 126.0, 127.5, 128.3 (d, *J* = 3.3 Hz), 128.5 (d, *J* = 12.2 Hz), 129.0 (d, *J* = 8.7 Hz) (s), 131.4 (d, *J* = 2.6 Hz), 132.2 (d, *J* = 5.7 Hz) (s), 132.4 (d, *J* = 101.3 Hz) (s), 132.6 (d, *J* = 9.6 Hz), 133.8 (d, *J* = 2.1 Hz) (s), 138.4 (d, *J* = 1.2 Hz), 143.9 (d, *J* = 1.6 Hz) (s). <sup>31</sup>P NMR (CDCl<sub>3</sub>, 121 MHz, H<sub>3</sub>PO<sub>4</sub>) δ = -2.4. MS *m/z* (I%): 443 (M<sup>+</sup>, 5), 262 (100). IR (nujol)  $\nu$  cm<sup>-1</sup>: 1637, 1557, 1407, 1153, 1131, 1116, 996, 843, 808, 755, 747, 725, 713, 696. Anal. Calcd for C<sub>31</sub>H<sub>26</sub>NP: C, 83.95; H, 5.91; N, 3.16. Found: C, 83.79; H, 5.78; N, 3.10.

**4.6.2. 2-(1-Methyl-2-propenyl)-1-(triphenylphosphoranylideneamino)naphthalene (6b).** Yield 42%; mp 138–139 °C; colorless prisms (diethyl ether/*n*-pentane). <sup>1</sup>H NMR (CDCl<sub>3</sub>) δ = 0.98 (d, 3H, *J* = 7.0 Hz), 4.05–4.12 (m, 1H), 4.77 (dt, 1H, *J* = 17.3, 1.9 Hz), 4.83 (dt, 1H, *J* = 10.5, 1.9 Hz), 5.57 (ddd, 1H, *J* = 17.3, 10.5, 4.9 Hz), 6.97 (ddd, 1H, *J* = 8.2, 6.8, 1.1 Hz), 7.14 (dd, 1H, *J* = 8.5, 1.5 Hz), 7.20 (ddd, 1H, *J* = 8.0, 6.8, 1.1 Hz), 7.28 (dd, 1H, *J* = 8.5, 2.5 Hz), 7.36–7.41 (m, 6H), 7.47–7.51 (m, 3H), 7.57–7.65 (m, 7H), 8.00 (d, 1H, *J* = 8.5 Hz). <sup>13</sup>C NMR (CDCl<sub>3</sub>) δ = 19.3, 37.0, 111.8, 119.2 (d, *J* = 3.8 Hz), 123.7, 124.3, 126.0 (d, *J* = 3.1 Hz), 126.3 (d, *J* = 1.3 Hz), 127.5, 128.5 (d, *J* = 11.9 Hz), 131.4 (d, *J* = 2.8 Hz), 132.2 (d, *J* = 5.5 Hz) (s), 132.3 (d, *J* = 101.2 Hz) (s), 132.6 (d, *J* = 9.5 Hz), 133.6 (d, *J* = 2.2 Hz) (s), 134.2 (d, *J* = 8.8 Hz) (s), 143.2 (d, *J* = 2.8 Hz) (s), 143.8 (d, *J* = 1.1 Hz). <sup>31</sup>P NMR (CDCl<sub>3</sub>, 121 MHz, H<sub>3</sub>PO<sub>4</sub>) δ = -2.0. MS *m/z* (I%): 457 (M<sup>+</sup>, 17), 262 (100). IR (nujol)  $\nu$  cm<sup>-1</sup>: 1630, 1559, 1505, 1436, 1303, 1158, 1131, 1114, 1098, 1029, 997, 897, 749, 727, 713, 697. Anal. Calcd for C<sub>32</sub>H<sub>28</sub>NP: C, 84.00; H, 6.17; N, 3.06. Found: C, 84.19; H, 6.06; N, 3.10.

#### 4.7. Reaction of 2-(2-propenyl)-1-(triphenylphosphoranylideneamino)naphthalene **6a** with ketenes

To a solution of 2-(2-propenyl)-1-(triphenylphosphoranylideneamino)naphthalene **6a** (0.55 g, 1.25 mmol) in anhydrous toluene (20 ml) a solution of diphenylketene (0.34 g, 1.75 mmol) or methylphenylketene (0.23 g, 1.75 mmol) in the same solvent (5 ml) was added. The reaction mixture was stirred at room temperature for 10 min, and then heated at reflux temperature for 1 h. After cooling at room temperature, the solvent was removed under reduced

pressure and the crude material was chromatographed on a silica gel column using hexanes/diethyl ether (9:1, v/v) as eluent.

**4.7.1. 13-Phenyl-7,7a,8,14-tetrahydrodibenz[*b,h*]acridine (8a).** Yield 40%; mp 212–213 °C; yellow prisms (diethyl ether). <sup>1</sup>H NMR (CDCl<sub>3</sub>) δ = 2.92–3.13 (m, 4H), 3.44–3.54 (m, 1H), 6.52 (dd, 1H, *J* = 7.6, 1.2 Hz), 6.79 (s, 1H), 6.91 (td, 1H, *J* = 7.2, 1.4 Hz), 6.95–6.99 (m, 1H), 7.07 (d, 2H, *J* = 8.3 Hz), 7.13 (d, 1H, *J* = 8.3 Hz), 7.21 (d, 1H, *J* = 8.3 Hz), 7.26–7.34 (m, 2H), 7.40–7.42 (m, 2H), 7.46 (tt, 1H, *J* = 7.4, 1.4 Hz), 7.56–7.60 (m, 2H), 7.68–7.71 (m, 1H). <sup>13</sup>C NMR (CDCl<sub>3</sub>) δ = 33.4, 34.9, 36.0, 110.1 (s), 116.4 (s), 118.3, 118.8, 121.5 (s), 122.9, 123.7, 125.2, 125.4, 126.7, 126.8, 126.9, 127.7, 128.8, 129.8, 131.2, 131.6 (s), 133.5 (s), 133.7 (s), 137.0 (s), 138.1 (s), 138.2 (s). MS *m/z* (I%): 359 (M<sup>+</sup>, 76), 354 (100). IR (nujol)  $\nu$  cm<sup>-1</sup>: 3428, 1622, 1594, 1563, 1334, 1314, 1293, 1277, 1182, 1156, 1098, 1011, 857, 803, 759, 737. Anal. Calcd for C<sub>27</sub>H<sub>21</sub>N: C, 90.21; H, 5.89; N, 3.90. Found: C, 90.35; H, 5.78; N, 3.83.

**4.7.2. 3,3-Diphenyl-4-vinyl-3,4-dihydrobenzo[*h*]quinoline (9a).** Yield 37%; mp 151–152 °C; colorless prisms (diethyl ether/*n*-pentane). <sup>1</sup>H NMR (CDCl<sub>3</sub>) δ = 4.22 (d, 1H, *J* = 8.4 Hz), 4.66 (ddd, 1H, *J* = 16.9, 1.5, 1.0 Hz), 4.78 (ddd, 1H, *J* = 10.1, 1.5, 0.6 Hz), 5.54 (ddd, 1H, *J* = 16.9, 10.1, 8.4 Hz), 7.08–7.16 (m, 3H), 7.19–7.33 (m, 7H), 7.36 (d, 1H, *J* = 8.3 Hz), 7.40–7.53 (m, 2H), 7.77 (d, 2H, *J* = 8.3 Hz), 8.56–8.60 (m, 1H), 8.71 (d, 1H, *J* = 1.2 Hz). <sup>13</sup>C NMR (CDCl<sub>3</sub>) δ = 49.9, 52.3 (s), 116.9, 123.6, 124.9 (s), 125.9, 126.0, 126.5, 126.9, 127.0, 127.7, 128.2, 128.3, 128.4, 128.6, 128.8, 130.3 (s), 133.5 (s), 136.1, 136.3 (s), 142.9 (s), 143.8 (s), 164.6. MS *m/z* (I%): 359 (M<sup>+</sup>, 93), 165 (100). IR (nujol)  $\nu$  cm<sup>-1</sup>: 1617, 1596, 1497, 1185, 1149, 1128, 1037, 997, 971, 951, 925, 885, 823, 768, 752, 701. Anal. Calcd for C<sub>27</sub>H<sub>21</sub>N: C, 90.21; H, 5.89; N, 3.90. Found: C, 90.32; H, 5.80; N, 3.79.

**4.7.3. 3-Methyl-3-phenyl-4-vinyl-3,4-dihydrobenzo[*h*]quinoline (9b).** Yield 73%. Mixture of two diastereoisomers (1:1). <sup>1</sup>H NMR (CDCl<sub>3</sub>) δ = 1.49 (s, 3H), 1.59 (s, 3H), 3.57 (d, 1H, *J* = 8.9 Hz), 3.77 (d, 1H, *J* = 9.4 Hz), 4.88–5.12 (m, 4H), 5.36–5.45 (m, 1H), 5.81–5.90 (m, 1H), 7.16–7.32 (m, 12H), 7.44–7.82 (m, 8H), 8.07 (s, 1H), 8.21 (s, 1H), 8.70 (d, 1H, *J* = 8.4 Hz), 8.76 (d, 1H, *J* = 8.4 Hz). <sup>13</sup>C NMR (CDCl<sub>3</sub>) δ = 19.5, 23.2, 43.7 (s), 43.8 (s), 52.5, 52.6, 118.2, 118.7, 123.6, 123.7, 124.3 (s), 124.6 (s), 125.7, 125.8, 125.9, 126.0, 126.4, 126.5, 126.7, 126.8, 127.1, 127.5, 127.6, 127.7, 127.9, 128.4, 128.5, 130.1 (s), 130.2 (s), 133.2 (s), 133.5 (s), 133.6 (s), 135.0, 136.3, 136.7 (s), 140.0 (s), 144.0 (s), 167.8, 168.4. MS *m/z* (I%): 297 (M<sup>+</sup>, 66), 280 (100). IR (neat)  $\nu$  cm<sup>-1</sup>: 1620, 1600, 1582, 1562, 1494, 1444, 1376, 1264, 1212, 1144, 1074, 1028, 1000, 922, 818, 758. Anal. Calcd for C<sub>22</sub>H<sub>19</sub>N: C, 88.85; H, 6.44; N, 4.71. Found: C, 88.55; H, 6.78; N, 4.66.

#### 4.8. Reaction of 2-(1-methyl-2-propenyl)-1-(triphenylphosphoranylideneamino)naphthalene **6b** with diphenylketene

To a solution of 2-(1-methyl-2-propenyl)-1-(triphenylphosphoranylideneamino)naphthalene **6b** (0.69 g, 1.5 mmol) in anhydrous toluene (20 ml) a solution of diphenylketene

(0.44 g, 2.25 mmol) in the same solvent (5 ml) was added. The reaction mixture was stirred at room temperature for 10 min, and then heated at reflux temperature for 1 h. After cooling at room temperature, the solvent was removed under reduced pressure and the crude material was chromatographed on a silica gel column, using hexanes/diethyl ether (20:1, v/v) as eluent, upto the total elution of **8b**, and then hexanes/diethyl ether (9:1, v/v).

We could not separate chromatographically compound **8b** from an unidentified impurity. Thus, after removing the solvent from the fractions containing compound **8b** the residue was treated with diethyl ether (4 ml), from which pure **8b** crystallized.

**4.8.1. 7-Methyl-13-phenyl-7,7a,8,14-tetrahydrodibenz[b,h]acridine (8b).** Yield 14%. Mixture of two diastereoisomers (1:1).  $^1\text{H}$  NMR ( $\text{CDCl}_3$ )  $\delta$  = 1.26 (d, 3H,  $J$  = 7.0 Hz), 1.57 (d, 3H,  $J$  = 6.1 Hz), 2.76 (dd, 1H,  $J$  = 15.2, 6.6 Hz), 2.97–3.09 (m, 4H), 3.18–3.21 (m, 1H), 3.30 (t, 1H,  $J$  = 15.2 Hz), 3.44–3.52 (m, 1H), 6.51 (dd, 1H,  $J$  = 7.6, 1.4 Hz), 6.56 (dd, 1H,  $J$  = 7.6, 1.2 Hz), 6.77 (s, 1H), 6.88 (s, 1H), 6.90–7.01 (m, 3H), 7.07–7.13 (m, 4H), 7.16–7.49 (M, 15H), 7.60 (t, 4H,  $J$  = 7.1 Hz), 7.70–7.72 (m, 2H).  $^{13}\text{C}$  NMR ( $\text{CDCl}_3$ )  $\delta$  = 15.6, 16.5, 31.5, 34.4, 35.0, 35.3, 37.9, 41.1, 110.2 (s), 111.4 (s), 118.5, 118.6, 118.8, 119.1, 120.6 (s), 121.3 (s), 121.7 (s), 122.7, 122.8, 123.4, 123.6, 123.7, 123.8 (s), 125.2, 125.3, 125.4, 126.5, 126.6, 126.8, 127.0, 127.1, 127.2, 127.7, 128.6, 128.8, 129.9, 131.4, 131.5 (s), 132.0 (s), 132.2 (s), 133.1 (s), 133.3 (s), 133.4 (s), 136.5 (s), 137.0 (s), 137.1 (s), 137.5 (s), 137.9 (s), 138.0 (s). MS  $m/z$  (I%): 373 ( $\text{M}^+$ , 100). IR (nujol)  $\nu$   $\text{cm}^{-1}$ : 3436, 1620, 1594, 1564, 1296, 1275, 1210, 1191, 1109, 1041, 942, 926, 858, 804, 759, 743, 708. Anal. Calcd for  $\text{C}_{28}\text{H}_{23}\text{N}$ : C, 90.04; H, 6.21; N, 3.75. Found: C, 89.85; H, 6.29; N, 3.86.

**4.8.2. 4-Methyl-3-(2,2-diphenylethyl)benzo[h]quinoline (13).** Yield 17%; mp 197–198 °C; colorless prisms (diethyl ether).  $^1\text{H}$  NMR ( $\text{CDCl}_3$ )  $\delta$  = 2.46 (s, 3H), 3.61 (d, 2H,  $J$  = 7.7 Hz), 4.27 (t, 1H,  $J$  = 7.7 Hz), 7.17–7.27 (m, 10H), 7.62–7.72 (m, 2H), 7.79 (d, 1H,  $J$  = 9.1 Hz), 7.85–7.89 (m, 2H), 8.49 (s, 1H), 9.19–9.23 (m, 1H).  $^{13}\text{C}$  NMR ( $\text{CDCl}_3$ )  $\delta$  = 14.3, 37.6, 52.7, 121.6, 124.6, 125.5 (s), 126.6, 127.0, 127.3, 127.6, 127.8, 128.1, 128.6, 131.8 (s), 131.9 (s), 132.9 (s), 141.7 (s), 143.9 (s), 144.6 (s), 150.7. MS  $m/z$  (I%): 373 ( $\text{M}^+$ , 16), 167 (100). IR (nujol)  $\nu$   $\text{cm}^{-1}$ : 1600, 1577, 1518, 1495, 1338, 827, 799, 753, 743, 727, 704. Anal. Calcd for  $\text{C}_{28}\text{H}_{23}\text{N}$ : C, 90.04; H, 6.21; N, 3.75. Found: C, 89.84; H, 6.29; N, 3.85.

#### 4.9. Preparation of 13-phenyldibenz[b,h]acridines 14

To a solution of the corresponding 7,7a,8,14-tetrahydrodibenz[b,h]acridine **8** (150 mg) in *ortho*-xylene (5 ml) Pd/C (75 mg) was added, and the reaction mixture was heated at reflux temperature for 3 h. The hot solution was filtered over a short path of Celite, which was further washed with toluene (3  $\times$  5 ml). The solvent was removed under reduced pressure and the resulting red solid was purified by column chromatography [silica gel; hexanes/diethyl ether (10:1, v/v)].

**4.9.1. 13-Phenyldibenz[b,h]acridine (14a).** Yield 97%; mp 202–203 °C; red prisms (diethyl ether).  $^1\text{H}$  NMR ( $\text{CDCl}_3$ )

$\delta$  = 7.36–7.46 (m, 2H), 7.49 (d, 1H,  $J$  = 9.3 Hz), 7.52–7.72 (m, 9H), 8.01–8.05 (m, 2H), 8.56 (s, 1H), 8.67 (s, 1H), 8.89–8.92 (m, 1H).  $^{13}\text{C}$  NMR ( $\text{CDCl}_3$ )  $\delta$  = 124.7 (s), 125.4, 125.7, 125.8, 125.9, 126.6, 127.1, 127.3, 127.5, 127.6, 127.7, 127.8, 128.6, 129.3, 131.5 (s), 132.2 (s), 132.3 (s), 132.5, 134.0 (s), 134.9, 137.8 (s), 138.3 (s), 142.1 (s), 148.5 (s). FAB(+)  $m/z$  (I%): 356 ( $\text{M}^+$  + 1, 100). IR (nujol)  $\nu$   $\text{cm}^{-1}$ : 1631, 1594, 1329, 1308, 1157, 1140, 1123, 1073, 1009, 962, 922, 874, 845, 803, 755, 700, 692. Anal. Calcd for  $\text{C}_{27}\text{H}_{17}\text{N}$ : C, 91.24; H, 4.82; N, 3.94. Found: C, 91.09; H, 4.89; N, 3.99.

**4.9.2. 7-Methyl-13-phenyldibenz[b,h]acridine (14b).** Yield 82%; mp 213–214 °C; red prisms (diethyl ether).  $^1\text{H}$  NMR ( $\text{CDCl}_3$ )  $\delta$  = 3.20 (s, 3H), 7.41 (ddd, 1H,  $J$  = 7.8, 6.4, 1.3 Hz), 7.46–7.50 (m, 1H), 7.53–7.72 (m, 9H), 7.92 (d, 1H,  $J$  = 9.5 Hz), 7.99–8.02 (m, 1H), 8.10–8.13 (m, 1H), 8.85 (s, 1H), 8.89–8.91 (m, 1H).  $^{13}\text{C}$  NMR ( $\text{CDCl}_3$ )  $\delta$  = 14.1, 122.3, 122.7 (s), 123.4, 125.1 (s), 125.3, 126.0, 126.1, 127.0, 127.1, 127.3, 127.4, 127.5, 127.6, 129.0, 129.1, 131.3 (s), 131.9 (s), 132.6, 132.8 (s), 133.6 (s), 138.4 (s), 138.7 (s), 140.4 (s), 141.5 (s), 147.8 (s). FAB(+)  $m/z$  (I%): 370 ( $\text{M}^+$  + 1, 100). IR (nujol)  $\nu$   $\text{cm}^{-1}$ : 1557, 1543, 1509, 1157, 1074, 1027, 958, 869, 835, 792, 754, 738, 698, 681. Anal. Calcd for  $\text{C}_{28}\text{H}_{19}\text{N}$ : C, 91.02; H, 5.18; N, 3.80. Found: C, 90.81; H, 5.29; N, 3.88.

#### Acknowledgements

This work was supported by the MCYT and FEDER (Project BQU2001-0010) and Fundación Séneca-CARM (Project 00458/PI/04). One of us (M.-M. O.) thanks Fundación Cajamurcia for a fellowship.

#### References and notes

- (a) Carruthers, W. *Cycloaddition Reactions in Organic Synthesis*; Pergamon: Oxford, 1990. (b) Fringuelli, F.; Taticchi, A. *Dienes in the Diels–Alder Reaction*; Wiley-Interscience: New York, 1990. (c) Oppolzer, W. In *Trost, B. M., Fleming, I., Eds.; Comprehensive Organic Synthesis*; Pergamon: Oxford, 1991; Vol. 5, pp 315–399. (d) Brocksom, T. J.; Nakamura, J.; Ferreira, M. L.; Brocksom, U. *J. Braz. Chem. Soc.* **2001**, *12*, 597–622.
- (a) Evans, D. A.; Johnson, J. S. In *Jacobsen, E. N., Pfaltz, A., Yamamoto, H., Eds.; Comprehensive Asymmetric Catalysis*; Springer: Berlín, 1999; Vol. 3, pp 1177–1235. (b) Oppolzer, W. *Angew. Chem., Int. Ed. Engl.* **1984**, *23*, 876–889. (c) Corey, E. J. *Angew. Chem., Int. Ed.* **2002**, *41*, 1650–1667.
- Nicolau, K. C.; Snyder, S. A.; Montagnon, T.; Vassilikoginnakis, G. *Angew. Chem., Int. Ed.* **2002**, *41*, 1668–1698.
- (a) Boger, D. L.; Weinreb, S. M. *Hetero Diels–Alder Methodology in Organic Synthesis*; Academic: San Diego, 1987. (b) Weinreb, S. M. In *Trost, B. M., Fleming, I., Eds.; Comprehensive Organic Synthesis*; Pergamon: Oxford, 1991; Vol. 5, pp 401–449. (c) Boger, D. L. In *Trost, B. M., Fleming, I., Eds.; Comprehensive Organic Synthesis*; Pergamon: Oxford, 1991; Vol. 5, pp 451–512. (d) Boger, D. L. *Tetrahedron* **1983**, *39*, 2869–2939. (e) Sakamoto, M.;

- Kawasaki, T.; Ishii, K.; Tamura, O. *Yakugaku Zasshi* **2003**, *123*, 717–759.
5. (a) Stocking, E. M.; Williams, R. M. *Angew. Chem., Int. Ed.* **2003**, *42*, 3078–3115. (b) Oikawa, H.; Tokiwano, T. *Nat. Prod. Rep.* **2004**, *21*, 321–352.
6. (a) Barker, M. W. In *The Chemistry of Ketenes, Allenes and Related Compounds*; Patai, S., Ed.; Wiley-Interscience: Chichester, 1980; pp 701–720; part 2. (b) Dondoni, A. *Heterocycles* **1980**, *14*, 1547–1566. (c) Alajarín, M.; Vidal, A.; Tovar, F. *Targets Heterocycl. Syst.* **2000**, *4*, 293–326.
7. (a) Molina, P.; Alajarín, M.; Vidal, A. *Tetrahedron Lett.* **1991**, *32*, 5379–5382. (b) Molina, P.; Alajarín, M.; Vidal, A. *J. Org. Chem.* **1992**, *57*, 6703–6711.
8. Alajarín, M.; Vidal, A.; Tovar, F.; Conesa, C. *Tetrahedron Lett.* **1999**, *40*, 6127–6130.
9. Alajarín, M.; Vidal, A.; Ortín, M.-M.; Tovar, F. *Synthesis* **2002**, 2393–2398.
10. Alajarín, M.; Vidal, A.; Tovar, F. *Tetrahedron Lett.* **2000**, *41*, 7029–7032.
11. Methods for the synthesis of dibenz[*b,h*]acridines have been scarcely reported: (a) Buu-Hoi, N. P.; Jacquignon, P. *J. Chem. Soc.* **1951**, 2964–2968. (b) Étienne, A.; Staehelin, A. *Bull. Soc. Chim. Fr.* **1954**, 748–755.
12. (a) Slovirer, H. A. *J. Am. Chem. Soc.* **1949**, *71*, 3360–3362. For other preparations of **2a** and/or **2b** see: (b) Marcinkiewicz, S.; Green, J.; Mamalis, P. *Tetrahedron* **1961**, *14*, 208–222. (c) Inada, S.; Kurata, R.-i. *Bull. Chem. Soc. Jpn.* **1981**, *54*, 1581–1582. (d) Butsugan, Y.; Nagai, K.; Nagaya, F.; Tabuchi, H.; Yamada, K.; Araki, S. *Bull. Chem. Soc. Jpn.* **1988**, *61*, 1707–1714. (e) Shue, Y.-J.; Yang, S.-C.; Lai, H.-C. *Tetrahedron Lett.* **2003**, *44*, 1481–1485.
13. In the thermal treatment of the *N*-(2-propenyl)-1-naphthylamines **2**, the formation of other products besides the 2-(2-propenyl)-1-naphthylamines **3** was noted by Inada (see Ref. 12c), although these products were not isolated, and no mention to their putative structures was made.
14. Compound **5a**: (a) Gassman, P. G.; Schenk, W. N. *J. Org. Chem.* **1977**, *42*, 3240–3243. (b) Korda, A.; Wróbel, Z. *Synlett* **2003**, 1465–1466. Compound **5b**: (c) Babushkina, T. A.; Vasil'ev, A. M.; Shagalov, L. B.; Eraksina, V. N.; Tkachenko, T. A.; Suvorov, N. N. *Zh. Org. Khim.* **1975**, *11*, 864–871. (d) Tokunaga, M.; Ota, M.; Haga, M.-a.; Wakatsuki, Y. *Tetrahedron Lett.* **2001**, *42*, 3865–3868.
15. For a general review see: (a) Müller, T. E.; Beller, M. *Chem. Rev.* **1998**, *98*, 675–703. For a recent example of an hydroamination process based upon a well-defined calcium coordination complex see: (b) Crimmin, M. R.; Casely, I. J.; Hill, M. S. *J. Am. Chem. Soc.* **2005**, *127*, 2042–2043. For examples of transition-metal complex-catalyzed cyclization of aminoalkenes see: (c) Hegedus, L. S. In Trost, B. M., Fleming, I., Eds.; *Comprehensive Organic Synthesis*; Pergamon: Oxford, 1991; Vol. 4, pp 551–569. (d) Tsuji, J. *Palladium Reagents and Catalysts, Innovation in Organic Synthesis*; Wiley: Chichester, 1995. (e) Hegedus, L. S.; Allen, G. F.; Waterman, E. L. *J. Am. Chem. Soc.* **1976**, *98*, 2674–2676. (f) Hegedus, L. S.; Allen, G. F.; Bozell, J. J.; Waterman, E. L. *J. Am. Chem. Soc.* **1978**, *100*, 5800–5807. For examples of actinide and lanthanide complex-catalyzed cyclization of aminoalkenes see: (g) Li, Y.; Marks, T. J. *J. Am. Chem. Soc.* **1998**, *120*, 1757–1771. (h) Tian, S.; Arredondo, V. M.; Stern, C. L.; Marks, T. J. *Organometallics* **1999**, *18*, 2568–2570. (i) Ryu, J.-S.; Marks, T. J.; McDonald, F. E. *Org. Lett.* **2001**, *3*, 3091–3094. (j) Molander, G. A.; Dowdy, E. D. *J. Org. Chem.* **1998**, *63*, 8983–8988. (k) Molander, G. A.; Dowdy, E. D. *J. Org. Chem.* **1999**, *64*, 6515–6517. (l) Kim, Y. K.; Livinghouse, T.; Bercaw, J. E. *Tetrahedron Lett.* **2001**, *42*, 2933–2935. (m) Stubbert, B. D.; Stern, C. L.; Marks, T. J. *Organometallics* **2003**, *22*, 4836–4838. (n) Hong, S.; Marks, T. J. *Acc. Chem. Res.* **2004**, *37*, 673–686.
16. Sreekumar, R.; Padmakumar, R. *Tetrahedron Lett.* **1996**, *37*, 5281–5282.
17. Yadav, J. S.; Reddy, B. V. S.; Rasheed, M. A.; Kumar, H. M. S. *Synlett* **2000**, 487–488.
18. To our knowledge only one example of thermally induced, intramolecular hydroamination of aminoalkenes has been described: (a) Molina, P.; Alajarín, M.; Vidal, A. *J. Chem. Soc., Chem. Commun.* **1990**, 7–8. (b) Molina, P.; Alajarín, M.; Vidal, A. *J. Org. Chem.* **1990**, *55*, 6140–6147.
19. For examples of thermally induced electrocyclization of 3-azatrienes see, for instance: (a) Palacios, F.; Rubiales, G. *Tetrahedron Lett.* **1996**, *37*, 6379–6382. (b) Beccalli, E. M.; Clerici, F.; Gelmi, M. L. *Tetrahedron* **2000**, *56*, 4817–4821.
20. Goerdeler, J.; Lindner, C.; Zander, F. *Chem. Ber.* **1981**, *114*, 536–548.
21. Morel, G.; Marchand, E.; Foucaud, A. *J. Org. Chem.* **1985**, *50*, 771–778.
22. Ramana Rao, V. V.; Fulloon, B. E.; Bernhardt, P. V.; Koch, R.; Wentrup, C. *J. Org. Chem.* **1998**, *63*, 5779–5786.
23. Alajarín, M.; Molina, P.; Vidal, A.; Tovar, F. *Tetrahedron* **1997**, *53*, 13449–13472.
24. Taylor, E. C.; McKillop, A.; Hawks, G. H. *Org. Synth.* **1973**, *52*, 36–38.
25. Pracejus, H.; Wallura, G. *J. Prakt. Chem.* **1962**, *19*, 33–36.

# Convenient synthesis of tryptophols and tryptophol homologues by hydroamination of alkynes

Vivek Khedkar, Annegret Tillack, Manfred Michalik and Matthias Beller\*

*Leibniz-Institut für Organische Katalyse (IfOK) an der Universität Rostock e.V., Albert-Einstein-Str. 29a, D-18055 Rostock, Germany*

Received 15 April 2005; revised 30 May 2005; accepted 31 May 2005

Available online 17 June 2005

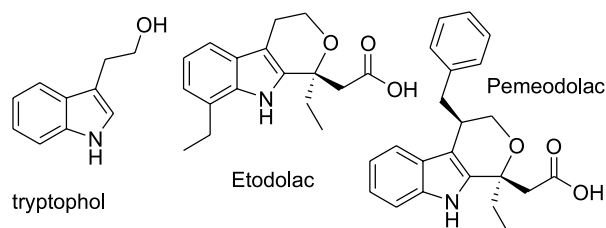
**Abstract**—A novel method is presented for the one-pot synthesis of substituted 3-(2-hydroxyethyl)- and 3-(3-hydroxypropyl)indoles (tryptophols and homotryptophols) from aryl hydrazines and silyl-protected  $\omega$ -(hydroxyalkyl)alkynes. Various tryptophol derivatives were prepared directly in good yield with excellent regioselectivity via a domino reaction sequence consisting of a titanium-catalyzed hydroamination of the alkyne, [3+3]-rearrangement of the resulting aryl hydrazone, and subsequent deprotection of the hydroxy group. © 2005 Elsevier Ltd. All rights reserved.

## 1. Introduction

There is a continuing interest in the development of new methods for the synthesis of indole derivatives due to their importance as building blocks for pharmaceuticals and natural products.<sup>1</sup> For some time, we have been involved in this area focusing on the application of catalytic methodologies such as hydrohydrazinomethylation of olefins,<sup>2</sup> carbonylations,<sup>3</sup> and hydroamination of alkynes<sup>4</sup> for the synthesis and refinement of indoles. Most notably, a new, one-pot method for the synthesis of functionalized tryptamines and tryptamine homologues starting from commercially available aryl hydrazines and chloroalkylalkynes has been developed by us.<sup>5</sup> Based on this work, we became interested in the preparation of tryptophol derivatives. Among the numerous naturally-occurring indoles, tryptophols<sup>6</sup> are characterized by a C-3 hydroxyethyl side chain that may or may not be  $\alpha$ - and or  $\beta$ -substituted.

The production of tryptophol, by tryptophan metabolism, has been implicated as one of the pathophysiological mechanisms that provoke sleeping sickness upon infection by trypanosomes.<sup>7</sup> Therefore, it is not surprising that a number of derivatives are known to possess interesting biological activity, for example, esters of 5-methoxytryptophol show anti-cholinergic activity.<sup>8</sup> Of pharmaceutical importance is also 7-ethyltryptophol as this compound is used for the synthesis of Etodolac,<sup>9</sup> a non-steroidal anti-inflammatory drug (NSAID).<sup>9</sup> In addition, 2-phenyl-2-(3-indolyl)-1-ethanol has

been used to prepare Pemedolac, a compound that has been found to be one of the most potent analgesics known and that displays anti-inflammatory activity similar to that of Etodolac (Scheme 1).<sup>10</sup>



**Scheme 1.** Examples of biologically active tryptophols.

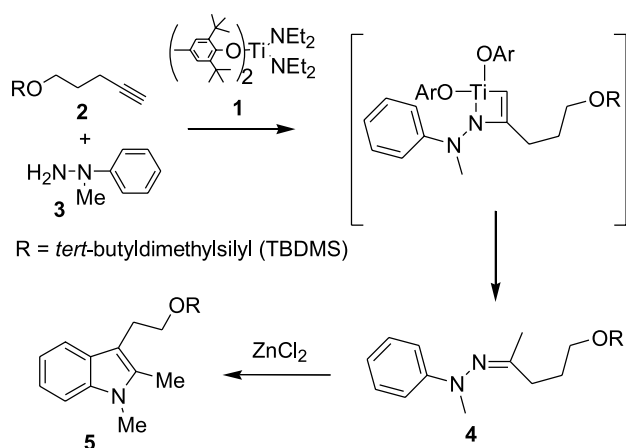
Although different creative approaches have been developed for the synthesis of tryptophols,<sup>11</sup> the Fischer indole reaction remains the most important method to create substituted indoles.<sup>12</sup> In this benchmark reaction, aldehydes or ketones react with aryl hydrazines to give the corresponding hydrazones, which subsequently undergo a [3,3]-sigmatropic rearrangement to yield the respective indole in the presence of a Brønsted or Lewis acid. Despite its versatility, the Fischer indole reaction with aldehydes constitutes a two-step procedure, which sometimes proceeds in low yield. More specifically the synthesis of tryptophol-like compounds via Fischer indole synthesis can be troublesome due to side-reactions of the free or protected hydroxyaldehyde. An elegant solution to this problem has been described very recently by Campos et al., who used substituted enol ethers or enol lactones as a substitute for the hydroxyaldehyde.<sup>13</sup>

**Keywords:** Amination; Indoles; Catalysis.

\* Corresponding author. Tel.: +49 381 1281113; fax: +49 381 12815000; e-mail: [matthias.beller@ifok.uni-rostock.de](mailto:matthias.beller@ifok.uni-rostock.de)

## 2. Results and discussion

Here, we describe for the first time a convenient synthesis of tryptophols from alkynes and aryl hydrazines. As shown in **Scheme 2**, our strategy involved as a key step, the titanium-catalyzed hydroamination of a suitably protected hydroxy-alkylalkyne to give the *N*-aryl-*N*-hydroxy-alkylhydrazone **4**. Then a [3,3]-sigmatropic rearrangement to the corresponding indole **5** should take place and finally deprotection will lead to the free tryptophol.



**Scheme 2.** Synthesis of tryptophols.

Indeed, when we reacted 1-*tert*-butyldimethylsilyloxy-4-pentyne **2** with *N*-methyl-*N*-phenylhydrazine **3** in the presence of 5 mol% bis(2,6-di-*tert*-butyl-4-methylphenoxo)-bis(diethylamido)titanium **1** (complex **1** is formed in situ from commercially available  $\text{Ti}(\text{NEt}_2)_4$  and 2,6-di-*tert*-butyl-4-methylphenol)<sup>14–16</sup> the corresponding hydrazone **4** was the major product. Subsequent treatment of the reaction mixture with an excess of  $\text{ZnCl}_2$  gave the corresponding silyl-protected tryptophol **6a** in 75% isolated yield!

It is noteworthy that the initial hydrohydrazination reaction of the alkyne proceeds selectively to give exclusively the 2,3-disubstituted indole **6a** (Markovnikov isomer).<sup>17</sup> Selective formation of the 2-methyl-indole derivative **6a** instead of the corresponding homotryptophol is explained by the relative stability of the corresponding imidotitanium alkyne  $\pi$ -complexes,<sup>4</sup> which undergo a formal [2+2]-cycloaddition to give the titanaazacyclobutene derivative. Subsequent protonation by excess hydrazine and tautomerization leads to the hydrazone product **4** and the active catalyst is recovered.

The model reaction of 1-*tert*-butyldimethylsilyloxy-4-pentyne with *N*-methyl-*N*-phenylhydrazine proceeds in the presence of  $\text{Ti}(\text{NEt}_2)_4$  and different aryloxo ligands. Subsequent addition of 3 equiv of  $\text{ZnCl}_2$  allowed for the cyclization of the initially generated hydrazone into the corresponding indole.

The reactions using different aryloxo ligands were performed at 100 °C for 24 h in toluene in the presence of 5 mol%  $\text{Ti}(\text{NEt}_2)_4$ . As shown in **Table 1**, all tested ligands gave selectively the Markovnikov addition product. In

**Table 1.** Reaction of 1-*tert*-butyldimethylsilyloxy-4-pentyne with *N*-methyl-*N*-phenylhydrazine<sup>a</sup>

Entry	Ligand	Ti(NEt <sub>2</sub> ) <sub>4</sub> (mol%)	Ligand (mol%)	Yield <sup>b</sup> <b>6a</b> (%)
1		5	10	<5
2		5	10	70
3		5	10	40
4		1	2	58
5		2.5	5	62
6		5	10	75
7		10	20	90

<sup>a</sup> Reaction conditions: for hydroamination: 2.0 mmol 1-*tert*-butyldimethylsilyloxy-4-pentyne, 2.4 mmol *N*-methyl-*N*-phenylhydrazine, 4 ml toluene, 100 °C, 24 h. For Fischer indole cyclization: 6.0 mmol  $\text{ZnCl}_2$ , 100 °C, 24 h.

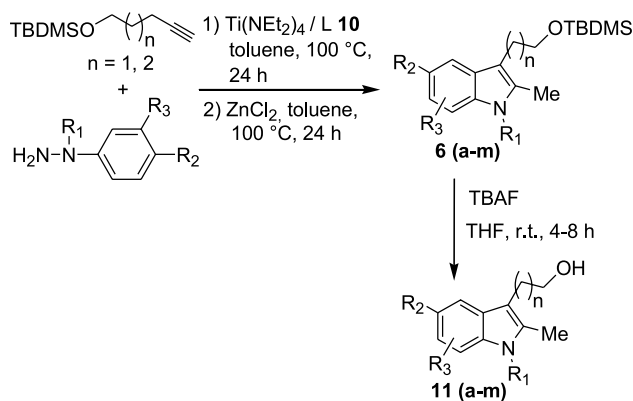
<sup>b</sup> Isolated yield based on 1-*tert*-butyldimethylsilyloxy-4-pentyne.

general, the sterically hindered monodentate ligand **10** gave higher yield compared to the less sterically hindered monodentate ligands **7** and **8** (**Table 1**, entries 1, 2, and 6). By employing ligand **7** the catalytic activity decreased to give only <5% yield.

The reaction using bidentate ligand **9** gave 40% yield of the corresponding indole **6a** (**Table 1**, entry 3). Therefore, further optimization of reaction conditions was carried out by using ligand **10**. Next, we turned our interest to improve the yield of product **6a** by loading different concentration of catalyst.

As shown in **Table 1**, an excellent yield (90%) of indole was achieved applying 10 mol%  $\text{Ti}(\text{NEt}_2)_4$  and 20 mol% of ligand **10** (**Table 1**, entry 7). Nevertheless, also at lower catalyst loading (1 mol%  $\text{Ti}(\text{NEt}_2)_4$  and 2 mol% **10**) a good yield (58%) of the corresponding indole **6a** was obtained (**Table 1**, entry 4).

Next, we were interested to test the in situ catalyst system for the one-pot synthesis of various functionalized tryptophols (**Scheme 3**; **Tables 2 and 3**). For this purpose, we used two silyl-protected 2- and 3-hydroxyalkylalkynes and



Scheme 3. Synthesis of different tryptophols.

various *N,N*-disubstituted aryl hydrazines. All formed indoles were deprotected by using *tetra-n*-butylammonium fluoride (TBAF) at room temperature for 4–8 h in THF.

Regioselective hydroamination/cyclization to the corresponding indole products **6a–m** was possible for a range of aryl hydrazines with different substituents such as Me, Cl, F, MeO, and Bn (40–97% yield). Interestingly, it is not necessary to purify or isolate the silyl-protected tryptophol. Hence, the reaction of *N*-benzyl-4-fluoro-phenylhydrazine and *N*-methyl-4-methylphenylhydrazine with 1-*tert*-butyldimethylsilyloxy-4-pentyne, and 1-*tert*-butyldimethylsilyloxy-5-hexyne gave in a one-pot reaction the tryptophols **11d** and **11j** in good isolated yields (Table 2, entry 4 and Table 3, entry 3).

Table 2. Reaction of 1-*tert*-butyldimethylsilyloxy-4-pentyne with various substituted hydrazines<sup>a</sup>

Entry	Alkyne	Hydrazine	Product <b>6</b>	Yield <sup>b</sup> (%)		
				<b>6</b>	<b>11 (a–g)</b>	
1				<b>6a</b>	90	81
2				<b>6b</b>	75	80
3				<b>6c</b>	84	90
4				<b>6d</b>	Not isolated	76
5				<b>6e</b>	80	85
6 <sup>c</sup>				<b>6f</b>	95	83
7 <sup>d</sup>				<b>6g</b>	84	89

<sup>a</sup> Reaction conditions: for hydroamination: 2–3 mmol 1-*tert*-butyldimethylsilyloxy-4-pentyne, 2.5–4.5 mmol arylhydrazine, 4 ml toluene, 100 °C, 24 h. For Fischer indole cyclization: 6.0 mmol ZnCl<sub>2</sub>, 100 °C, 24 h. For deprotection of alcohol: 2 equiv TBAF, rt, 4–8 h, 10 ml THF.

<sup>b</sup> Isolated yield based on 1-*tert*-butyldimethylsilyloxy-4-pentyne.

<sup>c</sup> Markovnikov:*anti*-Markovnikov selectivity = 97:3; 4-Cl:6-Cl regioselectivity = ~2:1.

<sup>d</sup> Markovnikov:*anti*-Markovnikov selectivity = 84:16; 4-Cl:6-Cl regioselectivity = ~2:1.

**Table 3.** Reaction of different alkynes with various substituted hydrazines<sup>a</sup>

Entry	Alkyne	Hydrazine	Product <b>6</b>	Yield <sup>b</sup> (%)	
				<b>6</b>	<b>11 (h–m)</b>
1				<b>6h</b>	85    90
2				<b>6i</b>	97    84
3				<b>6j</b>	Not isolated    75
4 <sup>c</sup>				<b>6k</b>	71    75
5 <sup>d</sup>				<b>6l</b>	84    88
6				<b>6m</b>	40    84

<sup>a</sup> Reaction conditions: for hydroamination: 2–3 mmol silyl-protected alkyne, 2.5–4.5 mmol arylhydrazine, 4 ml toluene, 100 °C, 24 h. For Fischer indole cyclization: 6.0 mmol ZnCl<sub>2</sub>, 100 °C, 24 h. For deprotection of alcohol: 2 equiv TBAF, room temperature, 4–8 h, 10 ml THF.

<sup>b</sup> Isolated yield based on alkyne.

<sup>c</sup> Markovnikov:*anti*-Markovnikov selectivity = 93:7; 4-Cl:6-Cl regioselectivity = ~2:1.

<sup>d</sup> Markovnikov:*anti*-Markovnikov selectivity = 83:17; 4-Cl:6-Cl regioselectivity = ~2:1.

Apart from terminal alkynes, an internal alkyne also reacted with *N*-methyl-*N*-phenylhydrazine to give the corresponding homotryptophol **6m** in 40% isolated yield (Table 3, entry 6).

In general, the hydrohydrazination step proceeds preferentially to the Markovnikov addition product. However, in case of disubstituted aryl hydrazines (Table 2, entries 6, 7 and Table 3, entries 4, 5) and *N*-benzyl-*N*-(3-chlorophenyl)hydrazine a small amount of the *anti*-Markovnikov addition product was also observed (M:*anti*-M = 84:16 to 97:3). In the second step subsequent cyclization of the hydrazones using an excess ZnCl<sub>2</sub> afforded the corresponding indoles in good yields (71–97%). The mixture of the Markovnikov and the *anti*-Markovnikov products (**11g** and **11l**) can be easily separated by column chromatography. However, it was not possible to separate the mixture of regioisomers (6-Cl:4-Cl) of the Markovnikov and the *anti*-Markovnikov products.

### 3. Conclusion

In conclusion, a new efficient method for the synthesis of functionalized tryptophols and tryptophol homologues has

been developed. Starting from commercially available aryl hydrazines and alkynes, a variety of potentially active indoles are obtained selectively in the presence of a catalytic amount of Ti(NEt<sub>2</sub>)<sub>4</sub> and 2,6-*tert*-butyl-4-methyl-phenol (**10**). The presented approach constitutes the most efficient access for the here shown substituted tryptophols and tryptophol homologues.

## 4. Experimental

### 4.1. General reagents

All reactions were carried out under an argon atmosphere. Starting materials were used as received from Aldrich, Fluka, Acros, and Strem and unless otherwise noted were used without further purification. Alkynes were degassed, flushed with argon and stored over molecular sieves (4 Å). Absolute solvents were purchased from Fluka<sup>®</sup>. The 2- and 3-hydroxyalkylalkynes were protected according to literature.<sup>18</sup>

Silica gel column chromatography was performed with 230–400 mesh ASTM silica gel from Merck,<sup>®</sup> which was used as received.



## 4.2. General spectroscopic methods

$^1\text{H}$  and  $^{13}\text{C}$  NMR data were recorded on a Bruker<sup>®</sup> ARX 400 with QNP probe head ( $^1\text{H}$ , 400.13 MHz), ( $^{13}\text{C}$ , 100.61, 125.75 MHz) at 25 °C. Resonances are reported in  $\delta$  (ppm) relative to  $\text{CDCl}_3$ . Coupling constants  $J$  are reported in Hz.  $^1\text{H}$  and  $^{13}\text{C}$  NMR assignments, where given, were based on 2D experiments or comparison with related structures. The following abbreviations were used to specify multiplicity, shape, and other properties: s, singlet; d, doublet; t, triplet; q, quartet; quint, quintet; sept, septet; m, multiplet; br, broad.

MS data were obtained on AMD 402/3 of AMD Intectra<sup>®</sup>. Electron impact spectra (EI) were recorded at 70 eV, chemical ionization (CI) was with *iso*-butane.

Melting points (mp) of the solid compounds were recorded on a Leica Galen III on the glass slide and are uncorrected.

IR spectra of solid compounds were recorded as KBr pellets (nujol) on a Nicolet<sup>®</sup> Magna 550. Liquid compounds were analyzed capillarially. Absorption bands are given as wavenumbers  $\tilde{\nu}$  in  $\text{cm}^{-1}$ .

## 4.3. General procedure for synthesis of tryptophols (GP)

*Step 1 (hydroamination/cyclization)*. In an Ace-pressure tube under an argon atmosphere the ligand 2,6-*tert*-butyl-4-methylphenol (20 mol%) was dissolved in 4 ml toluene. To this solution hydrazine, alkyne, and  $\text{Ti}(\text{NET}_2)_4$  (10 mol%) were added. The reaction mixture was heated at 100 °C for 24 h, which resulted in the formation of the corresponding hydrazone. The pressure tube was opened under argon and 3 equiv  $\text{ZnCl}_2$  was added. The reaction mixture was again heated at 100 °C for 24 h. After filtration and removal of the solvents in vacuo, the desired indole product was isolated by column chromatography in ethyl acetate/hexane.

*Step 2 (deprotection of alcohol)*. The indole isolated after step 1 was dissolved in 10 ml THF and cooled to 0 °C. Then 2 equiv of TBAF was added slowly. The reaction mixture was stirred at room temperature for 4–8 h. After removal of the solvent in vacuo, the mixture was diluted with water and 5 ml of dichloromethane. The product was extracted with dichloromethane ( $3 \times 25$  ml). The combined organic extracts were dried over anhydrous  $\text{MgSO}_4$  and concentrated in vacuo. The crude product was purified by column chromatography in ethyl acetate/hexane to yield the corresponding tryptophols.

**4.3.1. 3-(2-{*tert*-Butyldimethylsilyloxy}ethyl)-1,2-dimethyl-1H-indole (6a)**. According to GP (step 1), 1-*tert*-butyldimethylsilyloxy-4-pentyne (0.25 ml, 1.1 mmol) and *N*-methyl-*N*-phenylhydrazine (0.16 ml, 1.4 mmol) were employed. Isolated yield: 90%, light brown oil.

$^1\text{H}$  NMR ( $\text{CDCl}_3$ , 400 MHz):  $\delta$  = 7.50 (d,  $J$  = 7.7 Hz, 1H), 7.22 (d,  $J$  = 7.9 Hz, 1H), 7.13 (td,  $J$  = 1.1, 7.5 Hz, 1H), 7.06 (td,  $J$  = 1.0, 7.4 Hz, 1H), 3.75 (t,  $J$  = 7.8 Hz, 2H), 3.62 (s, 3H), 2.96 (t,  $J$  = 7.8 Hz, 2H), 2.35 (s, 3H), 0.89 (s, 9H), 0.03 (s, 6H).  $^{13}\text{C}$  NMR ( $\text{CDCl}_3$ , 100 MHz):  $\delta$  = 136.4, 133.6,

127.8, 120.4, 118.7, 117.8, 108.5, 107.4, 63.8, 29.4, 28.4, 25.9, 22.7, 10.2, –5.2. MS (EI, 70 eV)  $m/z$  (relative intensity): 303 (19) [ $\text{M}^+$ ], 246 (30), 231 (2), 205 (3), 189 (1), 172 (16), 158 (100), 143 (6), 128 (3), 115 (6), 91 (2), 73 (8), 41 (4), 28 (3). HRMS Calcd for  $\text{C}_{18}\text{H}_{29}\text{NOSi}$ : 303.20184. Found: 303.20170.

**4.3.2. *N*-Benzyl-3-(2-{*tert*-butyldimethylsilyloxy}ethyl)-2-methyl-1H-indole (6b)**. According to GP (step 1), 1-*tert*-butyldimethylsilyloxy-4-pentyne (0.25 ml, 1.1 mmol) and *N*-benzyl-*N*-phenylhydrazine (0.19 ml, 1.4 mmol) were employed. Isolated yield: 75%, light brown oil.

$^1\text{H}$  NMR ( $\text{CDCl}_3$ , 400 MHz):  $\delta$  = 7.55–7.53 (m, 1H), 7.24–7.18 (m, 4H), 7.10–7.07 (m, 2H), 6.97–6.95 (dd,  $J$  = 1.6, 8.3 Hz, 2H), 5.29 (s, 2H), 3.78 (t,  $J$  = 7.5 Hz, 2H), 2.98 (t,  $J$  = 7.6 Hz, 2H), 2.30 (s, 3H), 0.88 (s, 9H), 0.01 (s, 6H).  $^{13}\text{C}$  NMR ( $\text{CDCl}_3$ , 100 MHz):  $\delta$  = 138.0, 136.4, 133.5, 128.6, 128.1, 127.1, 125.9, 120.7, 118.9, 117.9, 108.9, 108.3, 63.7, 46.5, 28.4, 25.9, 18.4, 10.3, –5.2. MS (EI, 70 eV)  $m/z$  (relative intensity): 379 (27) [ $\text{M}^+$ ], 322 (24), 248 (10), 234 (88), 216 (5), 195 (11), 183 (13), 142 (7), 128 (1), 115 (3), 91 (100), 73 (10), 41 (4), 29 (3). HRMS Calcd for  $\text{C}_{24}\text{H}_{33}\text{NOSi}$ : 379.23315. Found: 379.23231.

**4.3.3. 3-(2-{*tert*-Butyldimethylsilyloxy}ethyl)-5-chloro-1,2-dimethyl-1H-indole (6c)**. According to GP (step 1), 1-*tert*-butyldimethylsilyloxy-4-pentyne (0.25 ml, 1.1 mmol) and *N*-(4-chlorophenyl)-*N*-methylhydrazine (0.22 ml, 1.65 mmol) were employed. Isolated yield: 84%, brown oil.

$^1\text{H}$  NMR ( $\text{CDCl}_3$ , 400 MHz):  $\delta$  = 7.49 (d,  $J$  = 1.7 Hz, 1H), 7.14 (d,  $J$  = 8.7 Hz, 1H), 7.09 (dd,  $J$  = 1.7, 8.5 Hz, 1H), 3.75 (t,  $J$  = 7.4 Hz, 2H), 3.64 (s, 3H), 2.92 (t,  $J$  = 7.4 Hz, 2H), 2.37 (s, 3H), 0.91 (s, 9H), 0.03 (s, 6H).  $^{13}\text{C}$  NMR ( $\text{CDCl}_3$ , 100 MHz):  $\delta$  = 135.1, 134.8, 128.9, 124.4, 120.4, 117.4, 109.3, 107.6, 63.7, 29.6, 28.2, 25.9, 18.3, 10.3, –5.3. MS (EI, 70 eV)  $m/z$  (relative intensity): 337 (18) [ $\text{M}^+$ ], 322 (4), 280 (52), 265 (2), 245 (1), 206 (29), 192 (100), 171 (10), 154 (12), 140 (7), 128 (2), 115 (4), 105 (3), 91 (1), 88 (9), 73 (9), 57 (4), 41 (4), 28 (3). HRMS Calcd for  $\text{C}_{18}\text{H}_{28}\text{ClNOSi}$ : 337.16287. Found: 337.16330.

**4.3.4. *N*-Benzyl-3-(2-{*tert*-butyldimethylsilyloxy}ethyl)-5-methoxy-2-methyl-1H-indole (6e)**. According to GP (step 1), 1-*tert*-butyldimethylsilyloxy-4-pentyne (0.47 ml, 2.0 mmol) and *N*-(4-methoxyphenyl)-*N*-methylhydrazine (228 mg, 2.4 mmol) were employed. Isolated yield: 80%, brown oil.

$^1\text{H}$  NMR ( $\text{CDCl}_3$ , 400 MHz):  $\delta$  = 7.22–7.17 (m, 3H), 7.12 (d,  $J$  = 8.4 Hz, 1H), 7.08–6.99 (m, 2H), 6.80–6.69 (m, 2H), 5.26 (s, 2H), 3.82 (s, 3H), 3.69 (t,  $J$  = 6.5 Hz, 2H), 2.70 (t,  $J$  = 6.5 Hz, 2H), 2.01 (s, 3H), 0.87 (s, 9H), 0.03 (s, 6H).  $^{13}\text{C}$  NMR ( $\text{CDCl}_3$ , 100 MHz):  $\delta$  = 154.9, 141.5, 137.9, 132.3, 128.6, 128.5, 127.1, 125.8, 110.5, 109.9, 107.9, 100.2, 62.1, 55.8, 46.4, 28.5, 25.9, 18.2, 10.3, –5.3. MS (EI, 70 eV)  $m/z$  (relative intensity): 409 (32) [ $\text{M}^+$ ], 352 (16), 303 (12), 278 (3), 264 (46), 251 (100), 212 (12), 186 (4), 160 (22), 144 (3), 129 (1), 115 (2), 91 (74), 73 (9), 59 (5), 41 (5), 28 (19). HRMS Calcd for  $\text{C}_{25}\text{H}_{35}\text{NO}_2\text{Si}$ : 409.24371. Found: 409.24235.

**4.3.5. *N*-Benzyl-3-(2-*tert*-butyldimethylsilyloxy)ethyl)-4-chloro-5-fluoro-2-methyl-1*H*-indole/*N*-benzyl-3-(2-*tert*-butyldimethylsilyloxy)ethyl)-6-chloro-5-fluoro-2-methyl-1*H*-indole (2:1) (6f).** According to GP (step 1), 1-*tert*-butyldimethylsilyloxy-4-pentyne (0.47 ml, 2.0 mmol) and *N*-(3-chloro-4-fluorophenyl)-*N*-benzylhydrazine (413 mg, 1.65 mmol) were employed. Isolated yield: 95%, brown oil.

<sup>1</sup>H NMR (CDCl<sub>3</sub>, 400 MHz): δ = 7.32–7.17 (m, 3H), 7.00 (dd, *J*<sub>H,H</sub> = 3.9 Hz, *J*<sub>F,H</sub> = 8.7 Hz, 1H), 6.95–6.91 (m, 2H), 6.85 (t, *J*<sub>H,H</sub> = *J*<sub>F,H</sub> = 8.9 Hz, 1H), 5.25 (s, 2H), 3.87 (t, *J* = 7.1 Hz, 2H), 3.22 (t, *J* = 7.1 Hz, 2H), 2.34 (s, 3H), 0.89 (s, 9H), 0.03 (s, 6H)/7.36 (d, *J*<sub>F,H</sub> = 9.0 Hz, 1H), 7.34–7.17 (m, 3H), 7.18 (d, *J*<sub>F,H</sub> = 6.1 Hz, 1H), 6.95–6.91 (m, 2H), 5.23 (s, 2H), 3.78 (t, *J* = 7.0 Hz, 2H), 2.92 (t, *J* = 7.0 Hz, 2H), 2.31 (s, 3H), 0.88 (s, 9H), 0.01 (s, 6H). <sup>13</sup>C NMR (CDCl<sub>3</sub>, 100 MHz): δ = 154.1, 137.2, 137.1, 133.6, 128.6, 127.4, 125.7, 125.0, 109.9, 109.2, 109.1, 107.7, 64.8, 46.7, 28.5, 25.9, 18.3, 10.5, –5.3/153.9, 137.0, 135.9, 133.7, 128.6, 127.4, 127.0, 125.7, 114.3, 109.2, 108.9, 104.2, 64.4, 46.7, 28.2, 25.9, 18.3, 10.4, –5.2. MS (EI, 70 eV) *m/z* (relative intensity): 432 (10) [M<sup>+</sup>], 397 (15), 340 (7), 316 (19), 286 (42), 262 (2), 235 (32), 205 (5), 195 (4), 185 (2), 159 (6), 142 (4), 129 (6), 115 (8), 99 (3), 91 (100), 77 (7), 65 (19), 57 (7), 49 (21), 41 (7), 28 (5). HRMS Calcd for C<sub>24</sub>H<sub>31</sub><sup>35</sup>ClFNOsi: 431.18475. Found: 431.18489.

**4.3.6. *N*-Benzyl-3-(2-*tert*-butyldimethylsilyloxy)ethyl)-4,5-dichloro-2-methyl-1*H*-indole/*N*-benzyl-3-(2-*tert*-butyldimethylsilyloxy)ethyl)-5,6-dichloro-2-methyl-1*H*-indole (2:1) (6g).** According to GP (step 1), 1-*tert*-butyldimethylsilyloxy-4-pentyne (0.47 ml, 2.0 mmol) and *N*-(3,4-dichlorophenyl)-*N*-benzylhydrazine (440 mg, 1.65 mmol) were employed. Isolated yield: 84%, brown oil.

<sup>1</sup>H NMR (CDCl<sub>3</sub>, 400 MHz): δ = 7.29–7.24 (m, 3H), 7.14 (d, *J* = 8.7 Hz, 1H), 7.01 (d, *J* = 8.7 Hz, 1H), 6.93–6.91 (m, 2H), 5.29 (s, 2H), 3.85 (t, *J* = 6.4 Hz, 2H), 3.79 (t, *J* = 6.4 Hz, 2H), 2.31 (s, 3H), 0.90 (s, 9H), 0.03 (s, 6H)/7.63 (s, 1H), 7.29–7.24 (m, 3H), 7.25 (s, 1H), 6.93–6.91 (m, 2H), 5.25 (s, 2H), 3.70 (t, *J* = 6.5 Hz, 2H), 3.94 (t, *J* = 6.5 Hz, 2H), 2.28 (s, 3H), 0.89 (s, 9H), 0.02 (s, 6H). <sup>13</sup>C NMR (CDCl<sub>3</sub>, 100 MHz): δ = 136.8, 136.5, 136.2, 128.1, 127.5, 125.4, 125.7, 123.5, 122.1, 120.6, 110.4, 108.4, 63.5, 46.7, 28.1, 25.9, 18.2, 10.4, –5.3/136.9, 135.8, 135.2, 128.1, 128.0, 127.5, 125.7, 124.3, 121.9, 119.2, 112.5, 108.7, 64.8, 46.7, 28.5, 25.9, 18.3, 10.4, –5.3. MS (EI, 70 eV) *m/z* (relative intensity): 447 (5) [M<sup>+</sup> – H], 390 (15), 356 (1), 316 (5), 302 (14), 291 (5), 265 (49), 251 (3), 215 (2), 181 (1), 145 (1), 115 (1), 91 (100), 75 (4), 65 (6), 57 (4), 41 (3), 28 (2). HRMS Calcd for C<sub>24</sub>H<sub>31</sub><sup>35</sup>Cl<sub>2</sub>NOSi: 447.15521. Found: 447.15576.

**4.3.7. 3-(3-*tert*-Butyldimethylsilyloxy)propyl)-1,2-dimethyl-1*H*-indole (6h).** According to GP (step 1), 1-*tert*-butyldimethylsilyloxy-5-hexyne (0.49 ml, 2.0 mmol) and *N*-methyl-*N*-phenylhydrazine (0.28 ml, 2.4 mmol) were employed. Isolated yield: 85%, light brown oil.

<sup>1</sup>H NMR (CDCl<sub>3</sub>, 400 MHz): δ = 7.51 (d, *J* = 7.9 Hz, 1H), 7.22 (d, *J* = 7.9 Hz, 1H), 7.12 (t, *J* = 1.0, 7.5 Hz, 1H), 7.04 (td, *J* = 0.8, 7.4 Hz, 1H), 3.64 (t, *J* = 6.1 Hz, 2H), 3.62 (s,

3H), 2.77 (t, *J* = 6.1 Hz, 2H), 2.34 (s, 3H), 1.80 (quint, *J* = 6.8 Hz, 2H), 0.92 (s, 9H), 0.05 (s, 6H). <sup>13</sup>C NMR (CDCl<sub>3</sub>, 100 MHz): δ = 136.5, 132.7, 127.7, 120.3, 118.4, 118.0, 110.9, 108.3, 62.4, 34.0, 29.4, 25.9, 20.4, 18.2, 10.1, –5.2. MS (EI, 70 eV) *m/z* (relative intensity): 317 (44) [M<sup>+</sup>], 302 (4), 260 (70), 245 (6), 232 (5), 202 (4), 184 (13), 170 (7), 158 (100), 144 (8), 130 (4), 115 (3), 89 (11), 75 (6), 59 (8), 41 (1), 29 (1). HRMS Calcd for C<sub>19</sub>H<sub>31</sub>NOSi: 317.21750. Found: 317.21704.

**4.3.8. *N*-Benzyl-3-(3-*tert*-butyldimethylsilyloxy)propyl)-2-dimethyl-1*H*-indole (6i).** According to GP (step 1), 1-*tert*-butyldimethylsilyloxy-5-hexyne (0.49 ml, 2.0 mmol) and *N*-benzyl-*N*-phenylhydrazine (0.43 ml, 3.0 mmol) were employed. Isolated yield: 97%, light brown oil.

<sup>1</sup>H NMR (CDCl<sub>3</sub>, 400 MHz): δ = 7.57–7.55 (m, 1H), 7.24–7.17 (m, 4H, H-21), 7.10–7.05 (m, 2H), 6.94 (d, *J* = 6.9 Hz, 2H), 5.28 (s, 2H), 3.63 (t, *J* = 7.4 Hz, 2H), 2.81 (t, *J* = 7.4 Hz, 2H), 2.28 (s, 3H), 1.84 (quint, *J* = 7.3 Hz, 2H), 0.91 (s, 9H), 0.05 (s, 6H). <sup>13</sup>C NMR (CDCl<sub>3</sub>, 100 MHz): δ = 138.2, 136.4, 132.6, 128.9, 128.6, 127.1, 125.9, 120.6, 118.7, 118.1, 111.6, 108.8, 62.4, 46.4, 33.8, 25.9, 20.4, 18.2, 10.1, –5.2. MS (EI, 70 eV) *m/z* (relative intensity): 393 (51) [M<sup>+</sup>], 378 (2), 336 (32), 308 (1), 286 (11), 245 (8), 234 (23), 195 (12), 167 (2), 143 (6), 115 (2), 91 (100), 76 (6), 57 (8), 41 (3). HRMS Calcd for C<sub>25</sub>H<sub>36</sub>NOSi: [M<sup>+</sup> + H]: 394.25662. Found: 394.25622.

**4.3.9. *N*-Benzyl-3-(3-*tert*-butyldimethylsilyloxy)propyl)-3-chloro-2-methyl-1*H*-indole/*N*-benzyl-3-(3-*tert*-butyldimethylsilyloxy)propyl)-3-dichloro-2-methyl-1*H*-indole (2:1) (6k).** According to GP (step 1), 1-*tert*-butyldimethylsilyloxy-5-hexyne (0.49 ml, 2.0 mmol) and *N*-(3-chlorophenyl)-*N*-benzylhydrazine (696 mg, 3.0 mmol) were employed. Isolated yield: 71%, brown oil.

<sup>1</sup>H NMR (CDCl<sub>3</sub>, 400 MHz): δ = 7.34–7.30 (m, 3H), 7.26–7.24 (m, 2H), 7.04 (t, *J* = 8.2 Hz, 1H), 6.59–6.56 (m, 2H), 4.61 (s, 2H), 3.62 (t, *J* = 6.0 Hz, 2H), 2.21 (t, *J* = 6.0 Hz, 2H), 1.93 (s, 3H), 1.64–1.58 (m, 2H), 0.88 (s, 9H), 0.03 (s, 6H)/7.34–7.30 (m, 3H), 7.21–7.19 (m, 3H), 6.59–6.56 (m, 2H), 4.61 (s, 2H), 3.62 (t, *J* = 6.8 Hz, 2H), 2.21 (t, *J* = 6.8 Hz, 2H), 1.93 (s, 3H), 1.64–1.58 (m, 2H), 0.89 (s, 9H), 0.04 (s, 6H). <sup>13</sup>C NMR (CDCl<sub>3</sub>, 100 MHz): δ = 137.7, 135.5, 130.1, 128.7, 127.0, 126.5, 125.7, 123.4, 116.6, 112.1, 110.5, 62.5, 54.0, 31.7, 25.9, 24.9, 18.1, 10.2, –5.3/137.7, 135.5, 130.1, 128.7, 127.0, 126.5, 125.7, 123.4, 116.6, 112.1, 110.5, 62.5, 54.0, 31.7, 25.9, 24.9, 18.1, 10.2, –5.3. MS (EI, 70 eV) *m/z* (relative intensity): 427 (39) [M<sup>+</sup> – H], 412 (2), 370 (45), 342 (6), 320 (1), 295 (3), 279 (14), 268 (17), 234 (10), 204 (2), 177 (2), 143 (2), 115 (2), 101 (2), 91 (100), 73 (6), 65 (5), 58 (4), 41 (3), 29 (1). HRMS Calcd for C<sub>25</sub>H<sub>34</sub><sup>35</sup>ClNOSi: 427.20981. Found: 427.20884.

**4.3.10. *N*-Benzyl-3-(3-*tert*-butyldimethylsilyloxy)propyl)-4,5-dichloro-2-methyl-1*H*-indole/*N*-benzyl-3-(3-*tert*-butyldimethylsilyloxy)propyl)-5,6-dichloro-2-methyl-1*H*-indole (2:1) (6l).** According to GP (step 1), 1-*tert*-butyldimethylsilyloxy-5-hexyne (0.49 ml, 2.0 mmol) and *N*-(3,4-dichlorophenyl)-*N*-benzylhydrazine (801 mg, 3.0 mmol) were employed. Isolated yield: 84%, brown oil.

$^1\text{H}$  NMR ( $\text{CDCl}_3$ , 400 MHz):  $\delta$  = 7.28–7.20 (m, 3H), 7.10 (d,  $J$  = 8.7 Hz, 1H), 7.00 (d,  $J$  = 8.7 Hz, 1H), 6.90–6.87 (m, 2H), 5.28 (s, 2H), 3.66 (t,  $J$  = 6.4 Hz, 2H), 3.00 (t,  $J$  = 6.4 Hz, 2H), 2.28 (s, 3H), 1.64–1.60 (m, 2H), 0.91 (s, 9H, H), 0.05 (s, 6H)/7.65 (s, 1H), 7.28–7.20 (m, 3H), 7.25 (s, 1H), 6.90–6.87 (m, 2H), 5.26 (s, 2H), 3.60 (t,  $J$  = 6.2 Hz, 2H), 2.75 (t,  $J$  = 6.2 Hz, 2H), 2.27 (s, 3H), 1.58–1.50 (m, 2H), 0.89 (s, 9H), 0.04 (s, 6H).  $^{13}\text{C}$  NMR ( $\text{CDCl}_3$ , 100 MHz):  $\delta$  = 137.1, 135.6, 130.5, 128.8, 128.4, 127.8, 127.5, 127.1, 125.7, 121.9, 110.3, 108.3, 62.5, 46.6, 35.6, 25.9, 22.9, 18.4, 10.4, –5.3/137.0, 130.5, 130.2, 128.7, 128.3, 127.8, 125.5, 123.5, 122.1, 119.1, 114.9, 108.7, 61.9, 46.7, 33.6, 25.9, 21.6, 18.3, 10.4, –5.3. MS (EI, 70 eV)  $m/z$  (relative intensity): 462 (75) [ $\text{M}^+$ ], 448 (8), 406 (100), 387 (18), 313 (28), 268 (25), 235 (6), 211 (7), 171 (8), 115 (8), 92 (20), 77 (15), 65 (4), 57 (11), 41 (9), 28 (5). HRMS Calcd for  $\text{C}_{23}\text{H}_{33}^{35}\text{Cl}_2\text{NOSi}$ : 461.17084. Found: 461.17087.

#### 4.3.11. 2-(1,2-Dimethyl-1H-indole-3-yl)ethanol (11a).<sup>19</sup>

According to GP (step 2), product **6a** (300 mg, 1.0 mmol) and TBAF-trihydrate (630 mg, 2.0 mmol) were employed. Isolated yield: 81%, colorless oil.

$^1\text{H}$  NMR ( $\text{CDCl}_3$ , 400 MHz):  $\delta$  = 7.52 (d,  $J$  = 7.9 Hz, 1H), 7.25 (d,  $J$  = 7.8 Hz, 1H), 7.16 (td,  $J$  = 1.1, 8.1 Hz, 1H), 7.07 (td,  $J$  = 1.0, 7.9 Hz, 1H), 3.81 (t,  $J$  = 6.4 Hz, 2H), 3.65 (s, 3H), 2.98 (t,  $J$  = 6.4 Hz, 2H), 2.37 (s, 3H), 1.52 (br, 1H, OH).  $^{13}\text{C}$  NMR ( $\text{CDCl}_3$ , 100 MHz):  $\delta$  = 136.6, 134.2, 127.7, 120.7, 118.9, 117.8, 108.6, 106.6, 62.9, 29.5, 27.9, 10.2. MS (EI, 70 eV)  $m/z$  (relative intensity): 189 (49) [ $\text{M}^+$ ], 170 (1), 158 (100), 143 (18), 128 (7), 115 (15), 102 (6), 91 (4), 84 (69), 77 (5), 57 (4), 47 (20), 41 (5), 29 (7). FT IR (neat,  $\text{cm}^{-1}$ ): 3366, 3052, 2934, 1614, 1566, 1473, 1432, 1411, 1370, 1331, 1245, 1193, 1149, 1129, 1041, 1021, 909, 886, 738, 647, 609, 560, 433. HRMS Calcd for  $\text{C}_{12}\text{H}_{15}\text{NO}$ : 189.11537. Found: 189.11525.

#### 4.3.12. 2-(N-Benzyl-2-methyl-1H-indole-3-yl)ethanol (11b).<sup>19</sup>

According to GP (step 2), product **6b** (296 mg, 0.78 mmol) and TBAF-trihydrate (492 mg, 1.6 mmol) were employed. Isolated yield: 80%, colorless oil.

$^1\text{H}$  NMR ( $\text{CDCl}_3$ , 400 MHz):  $\delta$  = 7.57 (d,  $J$  = 8.3 Hz, 1H), 7.27–7.19 (m, 4H), 7.14–7.07 (m, 2H), 6.96 (dd,  $J$  = 1.6, 6.5 Hz, 2H), 5.30 (s, 2H), 3.84 (t,  $J$  = 6.5 Hz, 2H), 3.02 (t,  $J$  = 6.5 Hz, 2H), 2.31 (s, 3H), 1.49 (br, 1H, OH).  $^{13}\text{C}$  NMR ( $\text{CDCl}_3$ , 100 MHz):  $\delta$  = 137.8, 136.5, 134.0, 128.7, 127.9, 127.2, 125.9, 121.0, 119.2, 117.9, 109.0, 107.4, 62.9, 46.5, 28.0, 10.3. MS (EI, 70 eV)  $m/z$  (relative intensity): 265 (100) [ $\text{M}^+$ ], 234 (66), 218 (49), 189 (2), 143 (24), 128 (6), 115 (13), 102 (14), 91 (89), 77 (14), 65 (33), 51 (10), 39 (11), 31 (22). FT IR (neat,  $\text{cm}^{-1}$ ): 3311, 3054, 2923, 2863, 1614, 1604, 1567, 1494, 1471, 1452, 1435, 1369, 1339, 1297, 1262, 1219, 1191, 1176, 1125, 1083, 1035, 1014, 922, 903, 873, 817, 749, 724, 694, 652, 554, 454, 432. HRMS Calcd for  $\text{C}_{18}\text{H}_{19}\text{NO}$ : 265.14667. Found: 265.14531.

#### 4.3.13. 2-(5-Chloro-2-methyl-1H-indole-3-yl)ethanol (11c).

According to GP (step 2), product **6c** (539 mg, 1.6 mmol) and TBAF (1 M in THF, 3.14 ml, 3.14 mmol) were employed. Isolated yield: 90%, white solid, mp: 64–67 °C.

$^1\text{H}$  NMR ( $\text{CDCl}_3$ , 400 MHz):  $\delta$  = 7.46 (d,  $J$  = 2.0 Hz, 1H), 7.13 (d,  $J$  = 8.7 Hz, 1H), 7.09 (dd,  $J$  = 2.0, 8.7 Hz, 1H), 3.78 (t,  $J$  = 6.5 Hz, 2H), 3.62 (s, 3H), 2.93 (t,  $J$  = 6.5 Hz, 2H), 2.36 (s, 3H), 1.49 (br, 1H, OH).  $^{13}\text{C}$  NMR ( $\text{CDCl}_3$ , 100 MHz):  $\delta$  = 135.7, 135.0, 128.7, 124.6, 120.8, 117.3, 109.5, 106.6, 62.8, 29.6, 27.8, 10.3. MS (EI, 70 eV)  $m/z$  (relative intensity): 223 (34) [ $\text{M}^+$ ], 192 (100), 177 (9), 157 (16), 142 (6), 128 (4), 115 (10), 101 (3), 87 (1), 75 (3), 63 (1), 56 (1), 42 (2), 31 (5). FT IR (nujol,  $\text{cm}^{-1}$ ): 3288, 2930, 2870, 1611, 1569, 1477, 1433, 1409, 1371, 1331, 1283, 1261, 1245, 1200, 1174, 1134, 1072, 1048, 985, 935, 897, 862, 809, 787, 747, 636, 585, 533, 476, 428. HRMS Calcd for  $\text{C}_{12}\text{H}_{14}^{35}\text{ClNO}$ : 223.07639. Found: 223.07672.

#### 4.3.14. 2-(N-Benzyl-5-fluoro-2-methyl-1H-indole-3-yl)ethanol (11d).

According to GP (step 2), crude product **6d** (964 mg, 3.0 mmol) and TBAF (1 M in THF, 6.0 ml, 6.0 mmol) were employed. Isolated yield: 76%, colorless oil.

$^1\text{H}$  NMR ( $\text{CDCl}_3$ , 400 MHz):  $\delta$  = 7.28–7.24 (m, 3H), 7.19 (dd,  $J_{\text{H,H}} = 2.3$  Hz,  $J_{\text{F,H}} = 9.5$  Hz, 1H), 7.19 (dd,  $J_{\text{F,H}} = 4.0$  Hz,  $J_{\text{H,H}} = 8.5$  Hz, 1H), 6.93 (d,  $J$  = 6.5 Hz, 2H), 6.83 (td,  $J_{\text{H,H}} = 2.3$  Hz,  $J_{\text{H,H}} = J_{\text{F,H}} = 9.1$  Hz, 1H), 5.27 (s, 2H), 3.82 (t,  $J$  = 6.5 Hz, 2H), 2.97 (t,  $J$  = 6.5 Hz, 2H), 2.31 (s, 3H), 1.57 (br, 1H, OH).  $^{13}\text{C}$  NMR ( $\text{CDCl}_3$ , 100 MHz):  $\delta$  = 159.0, 137.5, 135.8, 133.0, 128.8, 127.3, 125.8, 124.9, 109.6, 190.5, 109.1, 107.6, 62.8, 46.7, 28.0, 10.4. MS (EI, 70 eV)  $m/z$  (relative intensity): 283 (5) [ $\text{M}^+$ ], 266 (6), 252 (33), 239 (4), 213 (17), 199 (7), 162 (2), 122 (7), 115 (1), 91 (100), 75 (5), 65 (13), 39 (3), 28 (2). FT IR (neat,  $\text{cm}^{-1}$ ): 3357, 3063, 3030, 2935, 2877, 1706, 1622, 1604, 1583, 1506, 1482, 1453, 1419, 1359, 1300, 1250, 1204, 1139, 1140, 969, 851, 791, 728, 694, 629, 589, 433. HRMS Calcd for  $\text{C}_{18}\text{H}_{18}\text{FNO}$ : 283.13724. Found: 283.13764.

#### 4.3.15. 2-(N-Benzyl-5-methoxy-2-methyl-1H-indole-3-yl)ethanol (11e).

According to GP (step 2), product **6e** (328 mg, 0.8 mmol) and TBAF (1 M in THF, 1.6 ml, 1.6 mmol) were employed. Isolated yield: 85%, light green solid, mp: 78–80 °C.

$^1\text{H}$  NMR ( $\text{CDCl}_3$ , 400 MHz):  $\delta$  = 7.26–7.20 (m, 3H), 7.12 (m, 1H), 7.10–7.02 (m, 2H), 6.75 (dd,  $J$  = 2.1 Hz,  $J$  = 8.6 Hz, 2H), 5.28 (s, 2H), 3.80 (s, 3H), 3.68 (t,  $J$  = 7.5 Hz, 2H), 2.75 (t,  $J$  = 7.5 Hz, 2H), 2.04 (s, 3H), 1.47 (br, 1H, OH).  $^{13}\text{C}$  NMR ( $\text{CDCl}_3$ , 100 MHz):  $\delta$  = 154.0, 141.0, 137.9, 135.6, 134.7, 132.4, 128.7, 125.8, 110.7, 109.9, 101.9, 99.1, 62.0, 55.8, 46.4, 28.1, 10.4. MS (EI, 70 eV)  $m/z$  (relative intensity): 295 (66) [ $\text{M}^+$ ], 264 (31), 251 (75), 236 (6), 218 (2), 174 (7), 160 (57), 147 (4), 130 (5), 116 (4), 91 (100), 77 (3), 65 (10), 39 (2), 29 (1). FT IR (nujol,  $\text{cm}^{-1}$ ): 3368, 3052, 2931, 2852, 1610, 1596, 1460, 1445, 1372, 1321, 1249, 1186, 1128, 1085, 969, 877, 739, 692, 540, 432. HRMS Calcd for  $\text{C}_{19}\text{H}_{21}\text{NO}_2$ : 295.15723. Found: 295.15768.

#### 4.3.16. 2-(N-Benzyl-4-chloro-5-fluoro-2-methyl-1H-indole-3-yl)ethanol/2-(N-benzyl-6-chloro-5-fluoro-2-methyl-1H-indole-3-yl)ethanol (2:1) (11f).

According to GP (step 2), product **6f** (518 mg, 1.2 mmol) and TBAF (1 M in THF, 2.4 ml, 2.4 mmol) were employed. Isolated yield: 83%, white solid, mp: 74–77 °C.

$^1\text{H}$  NMR ( $\text{CDCl}_3$ , 400 MHz):  $\delta$ =7.27–7.18 (m, 3H), 6.99 (dd,  $J_{\text{H,H}}=3.9$  Hz,  $J_{\text{F,H}}=8.9$  Hz, 1H), 6.92–6.88 (m, 3H), 5.26 (m, 2H), 3.88 (t,  $J=6.8$  Hz, 2H), 3.24 (t,  $J=6.8$  Hz, 2H), 2.32 (s, 3H), 1.56 (br, 1H, OH)/7.29 (d,  $J_{\text{F,H}}=9.9$  Hz, 1H), 7.27–7.18 (m, 3H), 7.16 (d,  $J_{\text{F,H}}=6.0$  Hz, 1H), 6.92–6.88 (m, 2H), 5.23 (s, 2H), 3.80 (t,  $J=6.6$  Hz, 2H), 2.94 (t,  $J=6.6$  Hz, 2H), 2.30 (s, 3H), 1.56 (br, 1H, OH).  $^{13}\text{C}$  NMR ( $\text{CDCl}_3$ , 100 MHz):  $\delta$ =152.4, 136.9, 137.1, 133.7, 128.8, 127.5, 125.7, 124.8, 110.1, 109.5, 109.3, 107.8, 64.1, 46.8, 28.2, 10.5/152.2, 137.3, 136.3, 132.8, 128.8, 127.5, 126.7, 125.6, 114.0, 109.5, 107.9, 104.1, 62.7, 46.7, 27.9, 10.4. MS (EI, 70 eV)  $m/z$  (relative intensity): 317 (13) [ $\text{M}^+$ ], 286 (64), 262 (2), 235 (42), 205 (5), 195 (5), 185 (1), 159 (6), 145 (4), 129 (6), 117 (3), 109 (4), 99 (2), 91 (100), 77 (4), 65 (14), 57 (5), 49 (20), 41 (4), 28 (7). FT IR (nujol,  $\text{cm}^{-1}$ ): 3355, 3029, 2929, 2856, 1604, 1568, 1486, 1467, 1445, 1414, 1371, 1356, 1299, 1263, 1242, 1217, 1177, 1147, 1062, 1025, 986, 935, 856, 796, 766, 691, 605, 532, 465, 432. HRMS Calcd for  $\text{C}_{18}\text{H}_{17}^{35}\text{ClFNO}$ : 317.12207. Found: 317.12568.

**4.3.17. 2-(*N*-Benzyl-4,5-dichloro-2-methyl-1*H*-indole-3-yl)ethanol/2-(*N*-Benzyl-5,6-dichloro-2-methyl-1*H*-indole-3-yl)ethanol (2:1) (11g, M).** According to GP (step 2), product **6g** (897 mg, 2.0 mmol) and TBAF (1 M in THF, 4.0 ml, 4.0 mmol) were employed. Isolated yield: 60%, off white solid, mp: 95–97 °C.

$^1\text{H}$  NMR ( $\text{CDCl}_3$ , 400 MHz):  $\delta$ =7.27–7.22 (m, 3H), 7.12 (d,  $J=8.5$  Hz, 1H), 7.02 (d,  $J=8.7$  Hz, 1H), 6.92–6.88 (dd,  $J=1.0$ , 7.0 Hz, 2H), 5.27 (s, 2H), 3.88 (t,  $J=6.7$  Hz, 2H), 3.25 (t,  $J=6.7$  Hz, 2H), 2.33 (s, 3H), 1.55 (br, 1H, OH)/7.64 (s, 1H), 7.27–7.22 (m, 3H), 7.25 (s, 1H), 6.92–6.88 (dd,  $J=1.0$ ,  $J=7.0$  Hz, 2H), 5.23 (s, 2H), 3.81 (t,  $J=6.5$  Hz, 2H), 2.95 (t,  $J=6.5$  Hz, 2H), 2.30 (s, 3H), 1.55 (br, 1H, OH).  $^{13}\text{C}$  NMR ( $\text{CDCl}_3$ , 100 MHz):  $\delta$ =136.8, 136.2, 136.0, 128.2, 127.5, 125.8, 125.7, 123.8, 122.2, 119.0, 110.5, 108.5, 64.1, 46.8, 28.4, 10.5/136.9, 135.4, 135.2, 128.2, 128.0, 127.5, 125.8, 124.7, 123.0, 119.2, 108.2, 107.6, 62.8, 46.8, 27.8, 10.4. MS (EI, 70 eV)  $m/z$  (relative intensity): 333 (16) [ $\text{M}^+$  – H], 302 (23), 289 (13), 254 (2), 215 (2), 198 (2), 175 (3), 142 (4), 111 (1), 99 (2), 91 (100), 85 (26), 77 (2), 65 (10), 57 (2), 43 (11), 29 (4). FT IR (nujol,  $\text{cm}^{-1}$ ): 3356, 3029, 2928, 2856, 1678, 1603, 1537, 1499, 1457, 1426, 1411, 1370, 1345, 1290, 1243, 1222, 1207, 1176, 1147, 1062, 1027, 996, 933, 865, 776, 716, 696, 613, 525, 435, 439. HRMS Calcd for  $\text{C}_{18}\text{H}_{17}^{35}\text{Cl}_2\text{NO}$ : 333.06873. Found: 333.06876.

**4.3.18. 3-(*N*-Benzyl-4,5-dichloro-1*H*-indole-3-yl)propanol/3-(*N*-Benzyl-5,6-dichloro-1*H*-indole-3-yl)propanol (2:1) (11g, anti-M).** According to GP (step 2), product **6g** (1155.0 mg, 2.5 mmol) and TBAF (1 M in THF, 5.0 ml, 5.0 mmol) were employed. Isolated yield: 29%, off white solid, mp: 97–99 °C.

$^1\text{H}$  NMR ( $\text{CDCl}_3$ , 400 MHz):  $\delta$ =7.38–7.25 (m, 3H), 7.13 (d,  $J=8.7$  Hz, 1H), 7.03 (d,  $J=8.7$  Hz, 1H), 6.91–6.89 (dd,  $J=1.0$ , 6.3 Hz, 2H), 6.5 (s, 1H), 5.31 (s, 2H), 3.73–3.68 (m, 2H), 2.79 (t,  $J=6.5$  Hz, 2H), 2.02–1.91 (m, 2H), 1.57 (br, 1H, OH)/7.62 (s, 1H), 7.38–7.25 (m, 3H), 7.24 (s, 1H), 6.91–6.89 (dd,  $J=1.0$ , 6.3 Hz, 2H), 6.3 (s, 1H), 5.27 (s, 2H), 3.73–3.68 (m, 2H), 2.76 (t,  $J=6.5$  Hz, 2H), 2.02–1.91 (m, 2H), 1.57 (br, 1H, OH).  $^{13}\text{C}$  NMR ( $\text{CDCl}_3$ , 100 MHz):  $\delta$ =

136.8, 136.1, 130.8, 128.9, 127.5, 125.8, 125.6, 123.8, 122.3, 119.1, 110.8, 108.8, 61.8, 46.7, 31.0, 22.9/136.9, 135.4, 130.2, 128.5, 128.0, 127.5, 125.6, 124.7, 123.0, 119.2, 108.5, 107.5, 61.8, 46.5, 31.0, 22.9. MS (EI, 70 eV)  $m/z$  (relative intensity): 333 (16) [ $\text{M}^+$  – H], 302 (100), 289 (34), 254 (5), 215 (4), 199 (2), 176 (7), 141 (5), 115 (3), 101 (2), 91 (85), 85 (21), 77 (4), 65 (8), 57 (2), 43 (13), 29 (5). FT IR (nujol,  $\text{cm}^{-1}$ ): 3357, 3028, 2928, 2856, 1602, 1587, 1498, 1479, 1445, 1419, 1392, 1350, 1291, 1266, 1245, 1227, 1186, 1137, 1088, 1047, 996, 942, 875, 756, 716, 699, 623, 582, 475, 432. HRMS Calcd for  $\text{C}_{18}\text{H}_{17}^{35}\text{Cl}_2\text{NO}$ : 333.06873. Found: 333.06876.

**4.3.19. 3-(1,2-Dimethyl-1*H*-indole-3-yl)propanol (11h).** According to GP (step 2), product **6h** (507 mg, 1.6 mmol) and TBAF (1 M in THF, 3.2 ml, 3.2 mmol) were employed. Isolated yield: 90%, colorless oil.

$^1\text{H}$  NMR ( $\text{CDCl}_3$ , 400 MHz):  $\delta$ =7.51 (d,  $J=7.7$  Hz, 1H), 7.23 (d,  $J=8.1$  Hz, 1H), 7.14 (td,  $J=1.3$ , 8.2 Hz, 1H), 7.06 (td,  $J=1.2$ , 8.0 Hz, 1H), 3.67 (t,  $J=6.5$  Hz, 2H), 3.64 (s, 3H, H), 2.81 (t,  $J=6.5$  Hz, 2H), 2.35 (s, 3H), 1.87 (quint,  $J=6.5$  Hz, 2H), 1.32 (br, 1H, OH).  $^{13}\text{C}$  NMR ( $\text{CDCl}_3$ , 100 MHz):  $\delta$ =136.5, 132.8, 127.6, 120.4, 118.6, 117.8, 110.4, 108.5, 62.5, 33.6, 29.4, 20.4, 10.1. MS (EI, 70 eV)  $m/z$  (relative intensity): 203 (13) [ $\text{M}^+$ ], 172 (1), 158 (87), 143 (7), 128 (6), 115 (100), 102 (1), 91 (1), 75 (1), 65 (1), 55 (1), 42 (2), 28 (1). FT IR (neat,  $\text{cm}^{-1}$ ): 3355, 3051, 2935, 2855, 1613, 1566, 1472, 1440, 1410, 1370, 1331, 1247, 1191, 1148, 1128, 1060, 1013, 983, 919, 856, 738, 654, 559, 433. HRMS Calcd for  $\text{C}_{13}\text{H}_{17}\text{NO}$ : 203.13101. Found: 203.13123.

**4.3.20. 3-(*N*-Benzyl-2-methyl-1*H*-indole-3-yl)propanol (11i).<sup>20</sup>** According to GP (step 2), product **6i** (707 mg, 1.8 mmol) and TBAF (1 M in THF, 3.6 ml, 3.6 mmol) were employed. Isolated yield: 84%, colorless oil.

$^1\text{H}$  NMR ( $\text{CDCl}_3$ , 400 MHz):  $\delta$ =7.57–7.54 (m, 1H), 7.25–7.16 (m, 4H), 7.07–7.05 (m, 2H), 6.93 (d,  $J=6.5$  Hz, 2H), 5.27 (s, 2H), 3.64 (t,  $J=6.3$  Hz), 2.83 (t,  $J=6.3$  Hz, 2H), 2.27 (s, 3H), 1.89 (quint,  $J=6.3$  Hz, 2H), 1.49 (br, 1H, OH).  $^{13}\text{C}$  NMR ( $\text{CDCl}_3$ , 100 MHz):  $\delta$ =138.0, 136.4, 132.6, 128.6, 127.8, 127.1, 125.8, 120.7, 118.9, 118.9, 111.1, 108.9, 62.4, 46.4, 33.4, 20.4, 10.1. MS (EI, 70 eV)  $m/z$  (relative intensity): 279 (31) [ $\text{M}^+$ ], 234 (68), 218 (41), 189 (4), 142 (23), 129 (8), 115 (18), 102 (11), 91 (100), 77 (14), 65 (23), 51 (13), 39 (11), 31 (17). FT IR (neat,  $\text{cm}^{-1}$ ): 3361, 3053, 3029, 2933, 2858, 1605, 1584, 1567, 1495, 1468, 1453, 1415, 1367, 1336, 1300, 1260, 1180, 1147, 1062, 1028, 974, 919, 850, 738, 696, 634, 558, 455, 434. HRMS Calcd for  $\text{C}_{19}\text{H}_{20}\text{NO}$ : 279.16231. Found: 279.16249.

**4.3.21. 3-(1,2,3-Trimethyl-1*H*-indole-3-yl)propanol (11j).** According to GP (step 2), crude product **6j** and TBAF (1 M in THF, 6.0 ml, 6.0 mmol) were employed. Isolated yield: 75%, white solid, mp: 49–51 °C.

$^1\text{H}$  NMR ( $\text{CDCl}_3$ , 400 MHz):  $\delta$ =7.28 (s, 1H), 7.11 (d,  $J=8.1$  Hz, 1H), 6.95 (dd,  $J=1.6$ , 8.3 Hz, 1H), 3.65 (t,  $J=6.4$  Hz, 2H), 3.60 (s, 3H), 2.77 (t,  $J=6.4$  Hz, 2H, H), 2.44 (s, 3H), 2.32 (s, 3H), 1.87 (quint,  $J=6.4$  Hz, 2H), 1.45 (br, 1H, OH).  $^{13}\text{C}$  NMR ( $\text{CDCl}_3$ , 100 MHz):  $\delta$ =135.6, 134.9, 132.8,

127.7, 121.9, 117.6, 109.8, 108.1, 62.6, 33.6, 29.4, 21.4, 20.4, 10.1. MS (EI, 70 eV)  $m/z$  (relative intensity): 217 (27) [ $M^+$ ], 198 (1), 186 (2), 172 (100), 157 (5), 142 (2), 128 (2), 115 (4), 91 (2), 77 (1), 57 (2), 39 (1), 28 (1). FT IR (nujol,  $\text{cm}^{-1}$ ): 3295, 3014, 2917, 2850, 1619, 1581, 1565, 1489, 1443, 1410, 1370, 1321, 1299, 1246, 1208, 1181, 1156, 1135, 1072, 1028, 912, 896, 862, 781, 751, 694, 661, 586, 505, 430. HRMS Calcd for  $C_{14}H_{19}NO$ : 217.14667. Found: 217.14671.

**4.3.22. 3-(*N*-Benzyl-4-chloro-1*H*-indole-3-yl)propanol/3-(*N*-Benzyl-6-chloro-1*H*-indole-3-yl) propanol (2:1) (11k).** According to GP (step 2), product **6k** (728 mg, 1.7 mmol) and TBAF (1 M in THF, 3.4 ml, 3.4 mmol) were employed. Isolated yield: 75%, colorless oil.

$^1\text{H}$  NMR ( $\text{CDCl}_3$ , 400 MHz):  $\delta$  = 7.45 (d,  $J$  = 8.3 Hz, 1H), 7.30–7.21 (m, 4H), 6.92 (t,  $J$  = 8.2 Hz, 1H), 6.91–6.89 (m, 2H), 5.27 (s, 2H), 3.70 (t,  $J$  = 6.3 Hz, 2H), 3.05 (t,  $J$  = 6.3 Hz, 2H), 2.29 (s, 3H), 1.91–1.80 (m, 2H), 1.40 (br, 1H, OH)/7.30–7.21 (m, 3H), 7.17 (d,  $J$  = 1.8 Hz, 1H), 6.98–6.94 (m, 2H), 6.91–6.89 (m, 2H), 5.23 (s, 2H), 3.64 (t,  $J$  = 6.2 Hz, 2H), 2.81 (t,  $J$  = 6.2 Hz, 2H), 2.27 (s, 3H), 1.91–1.80 (m, 2H), 1.40 (br, 1H, OH).  $^{13}\text{C}$  NMR ( $\text{CDCl}_3$ , 100 MHz):  $\delta$  = 137.4, 136.8, 135.6, 128.7, 127.3, 126.5, 125.3, 124.3, 120.6, 119.5, 108.9, 107.7, 62.4, 46.6, 33.4, 21.5, 10.2/137.9, 134.3, 133.5, 128.7, 127.3, 126.6, 125.7, 125.3, 118.8, 111.6, 107.9, 62.2, 46.6, 32.2, 21.0, 10.1. MS (EI, 70 eV)  $m/z$  (relative intensity): 313 (70) [ $M^+$ ], 268 (94), 254 (17), 246 (3), 204 (3), 178 (4), 164 (3), 142 (6), 115 (5), 100 (2), 91 (100), 77 (4), 65 (17), 55 (5), 43 (12), 29 (7). FT IR (neat,  $\text{cm}^{-1}$ ): 3354, 3028, 2928, 2855, 1605, 1598, 1567, 1496, 1477, 1445, 1419, 1373, 1356, 1298, 1263, 1243, 1219, 1176, 1137, 1068, 1027, 996, 932, 835, 766, 726, 696, 609, 532, 445, 433. HRMS Calcd for  $C_{19}H_{20}^{35}\text{ClNO}$ : 313.12335. Found: 313.12378.

**4.3.23. 3-(*N*-Benzyl-4,5-dichloro-2-methyl-1*H*-indole-3-yl)propanol/3-(*N*-Benzyl-5,6-dichloro-2-methyl-1*H*-indole-3-yl)propanol (2:1) (11l, M).** According to GP (step 2), product **6l** (1155.0 mg, 2.5 mmol) and TBAF (1 M in THF, 5.0 ml, 5.0 mmol) were employed. Isolated yield: 62%, white solid, mp: 70–73 °C.

$^1\text{H}$  NMR ( $\text{CDCl}_3$ , 400 MHz):  $\delta$  = 7.25–7.21 (m, 3H), 7.10 (d,  $J$  = 8.5 Hz, 1H), 6.99 (d,  $J$  = 8.5 Hz, 1H), 6.89–6.87 (m, 2H), 5.25 (s, 2H), 3.69 (t,  $J$  = 6.4 Hz, 2H), 3.04 (t,  $J$  = 6.4 Hz, 2H), 2.29 (s, 3H), 1.95–1.82 (m, 2H), 1.54 (br, 1H, OH)/7.60 (s, 1H), 7.25–7.21 (m, 3H), 7.24 (s, 1H), 6.89–6.87 (m, 2H), 5.21 (s, 2H), 3.64 (t,  $J$  = 6.3 Hz, 2H), 2.77 (t,  $J$  = 6.3 Hz, 2H), 2.27 (s, 3H), 1.95–1.82 (m, 2H), 1.54 (br, 1H, OH).  $^{13}\text{C}$  NMR ( $\text{CDCl}_3$ , 100 MHz):  $\delta$  = 137.0, 135.9, 135.0, 128.8, 127.4, 127.1, 125.7, 125.6, 124.4, 122.0, 111.1, 108.4, 62.2, 46.6, 35.3, 21.0, 10.2/137.0, 135.5, 130.1, 128.8, 127.6, 127.4, 125.7, 123.6, 122.1, 119.0, 112.1, 110.4, 61.9, 46.6, 33.3, 20.20, 10.1. MS (EI, 70 eV)  $m/z$  (relative intensity): 347 (14) [ $M^+$  – H], 302 (100), 286 (54), 267 (7), 238 (11), 205 (6), 185 (3), 158 (4), 149 (7), 128 (3), 115 (4), 99 (5), 91 (90), 77 (8), 65 (27), 57 (4), 41 (2), 31 (6). FT IR (nujol,  $\text{cm}^{-1}$ ): 3425, 3064, 3030, 2936, 2864, 1604, 1591, 1496, 1473, 1448, 1411, 1355, 1299, 1219, 1162, 1133, 1102, 1060, 1028, 889, 867, 837, 787,

732, 698, 632, 595, 456, 429. HRMS Calcd for  $C_{19}H_{19}^{35}\text{Cl}_2\text{NO}$ : 347.08438. Found: 347.08328.

**4.3.24. 3-(*N*-Benzyl-4,5-dichloro-1*H*-indole-3-yl)butanol/3-(*N*-Benzyl-5,6-dichloro-1*H*-indole-3-yl) butanol (2:1) (11i, anti-M).** According to GP (step 2), product **6i** (1155.0 mg, 2.5 mmol) and TBAF (1 M in THF, 5.0 ml, 5.0 mmol) were employed. Isolated yield: 26%, white solid, mp: 71–74 °C.

$^1\text{H}$  NMR ( $\text{CDCl}_3$ , 400 MHz):  $\delta$  = 7.27–7.21 (m, 3H), 7.09 (d,  $J$  = 8.7 Hz, 1H), 6.96 (d,  $J$  = 8.5 Hz, 1H), 6.87 (dd,  $J$  = 1.8, 7.3 Hz, 2H), 5.25 (s, 2H), 3.62–3.58 (m, 2H), 2.69–2.62 (m, 2H), 1.80–1.72 (m, 2H), 1.70–1.60 (m, 2H), 1.47 (br, 1H, OH)/7.61 (s, 1H), 7.27–7.21 (m, 3H), 7.25 (s, 1H), 6.87 (dd,  $J$  = 1.8, 7.3 Hz, 2H), 5.21 (s, 2H), 3.62–3.58 (m, 2H), 2.69–2.62 (m, 2H), 1.80–1.72 (m, 2H), 1.70–1.60 (m, 2H), 1.47 (br, 1H, OH).  $^{13}\text{C}$  NMR ( $\text{CDCl}_3$ , 100 MHz):  $\delta$  = 136.0, 136.61, 135.8, 128.9, 127.6, 127.5, 125.7, 125.6, 124.3, 122.1, 110.6, 108.7, 62.3, 46.6, 32.1, 26.4, 24.3/136.9, 135.5, 130.2, 128.9, 128.8, 127.6, 125.7, 122.9, 122.1, 120.6, 112.1, 110.4, 62.3, 46.4, 32.1, 26.3, 24.2. MS (EI, 70 eV)  $m/z$  (relative intensity): 347 (45) [ $M^+$ ], 302 (21), 289 (58), 276 (7), 253 (8), 238 (3), 214 (5), 198 (4), 175 (9), 149 (6), 149 (5), 127 (4), 111 (6), 99 (32), 91 (100), 71 (14), 65 (38), 57 (15), 43 (25), 31 (23). FT IR (nujol,  $\text{cm}^{-1}$ ): 3351, 3087, 3064, 3030, 2936, 2867, 1604, 1588, 1563, 1539, 1496, 1452, 1406, 1355, 1330, 1259, 1209, 1155, 1141, 1121, 1101, 1069, 1029, 983, 946, 906, 868, 837, 776, 732, 698, 654, 575, 468, 456. HRMS Calcd for  $C_{19}H_{19}^{35}\text{Cl}_2\text{NO}$ : 347.08438. Found: 347.08555.

**4.3.25. 3-(1-Methyl-2-phenyl-1*H*-indole-3-yl)propanol (11m).** According to GP (step 2), crude product **6m** and TBAF (1 M in THF, 0.6 ml, 0.6 mmol) were employed. Isolated yield: 84%, colorless oil.

$^1\text{H}$  NMR ( $\text{CDCl}_3$ , 400 MHz):  $\delta$  = 7.59 (d,  $J$  = 7.9 Hz, 1H), 7.48–7.41 (m, 4H), 7.31–7.27 (m, 2H), 7.21 (td,  $J$  = 1.2, 7.6 Hz, 1H), 7.09 (td,  $J$  = 1.0, 6.9 Hz, 1H), 3.73 (s, 3H), 3.52 (t,  $J$  = 6.6 Hz, 2H), 2.94 (t,  $J$  = 6.6 Hz, 2H), 1.80 (quint,  $J$  = 6.6 Hz, 2H), 1.52 (br, 1H, OH).  $^{13}\text{C}$  NMR ( $\text{CDCl}_3$ , 100 MHz):  $\delta$  = 136.7, 136.6, 135.5, 129.7, 128.5, 127.0, 125.9, 121.3, 119.6, 114.4, 108.8, 61.6, 32.6, 29.4, 20.7. MS (EI, 70 eV)  $m/z$  (relative intensity): 265 (67) [ $M^+$ ], 247 (1), 232 (4), 220 (100), 204 (25), 179 (10), 165 (4), 152 (2), 144 (14), 115 (10), 102 (4), 91 (2), 77 (4), 57 (5), 42 (10), 28 (3). FT IR (neat,  $\text{cm}^{-1}$ ): 3373, 3053, 2933, 2871, 1601, 1553, 1493, 1440, 1402, 1371, 1328, 1255, 1209, 1177, 1152, 1131, 1091, 1058, 940, 924, 844, 771, 743, 703, 675, 639, 610, 565, 501. HRMS Calcd for  $C_{18}H_{19}NO$ : 265.14667. Found: 265.14601.

### Acknowledgements

This work has been supported by the State of Mecklenburg–Vorpommern. In addition, financial support from the BMBF (Bundesministerium für Bildung und Forschung), the VCI, and Grüenthal AG are gratefully acknowledged. We thank Mrs. C. Mewes, Mrs. H. Baudisch, Mrs. A. Lehmann, and Mrs. S. Buchholz (all IfOK) for their excellent technical and analytical support.

## References and notes

- (a) Hong, K. B.; Lee, C. W.; Yum, E. K. *Tetrahedron Lett.* **2004**, *45*, 693–697. (b) Köhling, P.; Schmidt, A. M.; Eilbracht, P. *Org. Lett.* **2003**, *5*, 3213–3216. (c) Cacchi, S.; Fabrizi, G.; Parisi, L. M. *Org. Lett.* **2003**, *5*, 3843–3846. (d) Siebeneicher, H.; Bytschkov, I.; Doye, S. *Angew. Chem., Int. Ed.* **2003**, *42*, 3042–3044. (e) Onitsuka, K.; Suzuki, S.; Takahashi, S. *Tetrahedron Lett.* **2002**, *43*, 6197–6199. (f) Rutherford, J. F.; Rainka, M. P.; Buchwald, S. L. *J. Am. Chem. Soc.* **2002**, *124*, 15168–15169. (g) Tokunaga, M.; Ota, M.; Haga, M.; Wakatsuki, Y. *Tetrahedron Lett.* **2001**, *42*, 3865–3868. (h) Gribble, G. W. *J. Chem. Soc., Perkin Trans. 1* **2000**, 1045–1075. (i) Verspui, G.; Elbertse, G.; Sheldon, F. A.; Hacking, M. A. P. J.; Sheldon, R. A. *Chem. Commun.* **2000**, 1363–1364. (j) Beller, M.; Breindl, C.; Riermeier, T. H.; Eichberger, M.; Trauthwein, H. *Angew. Chem., Int. Ed.* **1998**, *37*, 3389–3391.
- Mobaligh, A.; Jackstell, R.; Beller, M. *Tetrahedron Lett.* **2004**, *45*, 869–873.
- Kumar, K.; Zapf, A.; Michalik, D.; Tillack, A.; Arlt, M.; Beller, M. *Org. Lett.* **2004**, *6*, 7–10.
- Tillack, A.; Jiao, H.; Garcia Castro, I.; Hartung, C. G.; Beller, M. *Chem. Eur. J.* **2004**, *10*, 2409–2420.
- (a) Khedkar, V.; Tillack, A.; Michalik, M.; Beller, M. *Tetrahedron Lett.* **2004**, *45*, 3123–3126. see also (b) Cao, C.; Shi, Y.; Odom, A. L. *Org. Lett.* **2002**, *4*, 2853–2856.
- (a) Mantle, P. G.; Weedon, C. M. *Phytochemistry* **1994**, *36*, 1209–1218. (b) Martens, D. A.; Frankenberger, W. T. *J. Soil Sci.* **1993**, *155*, 263–271. (c) Shin, M.; Shinguu, T.; Sano, K.; Umezawa, C. *Chem. Pharm. Bull.* **1991**, *39*, 1792–1795. (d) Sugawara, F.; Strobel, G. A. *Phytochemistry* **1987**, *26*, 1349–1352. (e) Ayer, W. A.; Browne, L. M.; Feng, M.-C.; Orszanska, H.; Saeedi-Ghomi, H. *Can. J. Chem.* **1986**, *64*, 904–909. (f) Kawashima, A.; Seto, H.; Kato, M.; Yasuda, A.; Uchida, K.; Otake, N. *J. Antibiot.* **1986**, *39*, 1495–1497; *Chem. Abstr.* **1986**, *106*, 29752q. (g) Lacan, G.; Magnus, V.; Simaga, S.; Iskrich, S.; Hall, P. J. *Plant Physiol.* **1985**, *78*, 447–454. (h) Fenn, P.; Durbin, R. D.; Kuntz, J. E. *Phytochemistry* **1977**, *16*, 899–901. (i) Ehrlich, F. *Ber.* **1909**, *45*, 883–889; *Chem. Abstr.* **1909**, *6*, 24272.
- (a) Vincendeau, P.; Lesthelle, S.; Bertazzo, A.; Okomo-Assoumou, M. C.; Allegri, G.; Costa, C. V. *Adv. Exp. Med. Biol.* **1999**, *467*, 525–531. (b) Cornford, E. M.; Crane, P. D.; Braun, L. D.; Bocash, W. D.; Nyerges, A. M.; Oldendorf, W. H. *J. Neurochem.* **1981**, *36*, 1758–1765.
- Fernando, I. N.; Francis, P. L.; Smith, I. *J. Neural. Transm.* **1983**, *56*, 33–41.
- Humber, L. G.; Ferdinandi, E.; Demerson, C. A.; Ahmed, S.; Shah, U.; Mobilio, D.; Sabatucci, J.; Lange, B. D.; Labbadia, F.; Hughes, P.; Virgilio, J. D.; Neuman, G.; Chau, T. T.; Weichman, B. M. *J. Med. Chem.* **1988**, *31*, 1712–1719.
- (a) Chau, T. T.; Walter, T.; Katz, A.; Weichman, B. M. *Drug Dev. Res.* **1993**, *28*, 488–495. (b) Katz, A. H.; Demerson, C. A.; Shaw, C. C.; Asselin, A. A.; Humber, L. G.; Conway, K. M.; Gavin, G.; Guinasso, C.; Jensen, N. P.; Mobilio, D.; Noureldin, R.; Schmid, J.; Shah, U.; Engen, D. V.; Chau, T. T.; Weichman, B. M. *J. Med. Chem.* **1988**, *31*, 1244–1250.
- (a) Garden, S. J.; Da Silva, R. B.; Pinto, A. C. *Tetrahedron* **2002**, *58*, 8399–8412. (b) Wagaw, S.; Yang, B. H.; Buchwald, S. L. *J. Am. Chem. Soc.* **1999**, *121*, 10251–10263. (c) Wagaw, S.; Yang, B. H.; Buchwald, S. L. *J. Am. Chem. Soc.* **1998**, *120*, 6621–6622. (d) Dong, Y.; Busacca, C. A. *J. Org. Chem.* **1997**, *62*, 984–990. (e) Zhang, D.; Liebeskind, L. S. *J. Org. Chem.* **1996**, *61*, 6464–6465. (f) Amat, M.; Coll, M. D.; Passarella, D.; Bosch, J. *Tetrahedron: Asymmetry* **1996**, *7*, 3091–3094. (g) Johnson, H. E. US Patent 3,197,479, 27 July, 1965; *Chem. Abstr.* **1965**, *63*, P13217f. (h) Kotsuki, H.; Hayaschida, K.; Shimanouchi, T.; Nishizawa, H. *J. Org. Chem.* **1996**, *61*, 984–990. (i) Kotsuki, H.; Teraguchi, M.; Shimomoto, N.; Ochi, M. *Tetrahedron Lett.* **1996**, *37*, 3727–3730. (j) Ghosh, A.; Wang, W.; Freeman, J. P.; Althaus, J. S.; Von Voigtlander, P. F.; Scahill, T. A.; Mizsak, S. A.; Szmuszkovicz, J. *Tetrahedron* **1991**, *47*, 8653–8662. (k) Soll, R. M.; Guinasso, C.; Asselin, A. *J. Org. Chem.* **1988**, *53*, 2844–2847. (l) Ito, Y.; Kobayaschi, K.; Seko, N.; Saegusa, T. *Bull. Chem. Soc. Jpn.* **1984**, *57*, 73–84. (m) Demerson, C. A.; Humber, L. G.; Philip, A. H.; Martel, R. R. *J. Med. Chem.* **1976**, *19*, 391–395. (n) Bergman, J. *Tetrahedron* **1971**, *27*, 1167–1171. (o) Tacconi, G. *Farmaco Ed. Sci.* **1965**, *20*, 891–901.
- (a) Robinson, B. *The Fischer Indole Synthesis*; Wiley: Chichester, 1982. (b) Hughes, D. L. *Org. Prep. Proced. Int.* **1993**, *25*, 607–623.
- Campos, K. R.; Woo, J. C. S.; Lee, S.; Tillyer, R. D. *Org. Lett.* **2004**, *6*, 79–82.
- Tillack, A.; Khedkar, V.; Beller, M. *Tetrahedron Lett.* **2004**, *45*, 8875–8878.
- Duff, A. W.; Kamarudin, R. A.; Lappert, M. F.; Norton, R. J. *J. Chem. Soc., Dalton Trans.* **1986**, 489–498.
- Khedkar, V.; Tillack, A.; Beller, M. *Org. Lett.* **2003**, *5*, 4767–4770.
- For a recent review on Markovnikov and anti-Markovnikov functionalization of olefins and alkynes see: Seayad, J.; Tillack, A.; Jiao, H.; Beller, M. *Angew. Chem., Int. Ed.* **2004**, *43*, 3368–3398.
- Snider, B. B.; Shi, Z. *J. Am. Chem. Soc.* **1994**, *116*, 549–557.
- Grandberg, I. I.; Tokmakov, G. P. *Khim. Geterotsikl. Soedin.* **1974**, *2*, 204.
- Dmitriev, L. B.; Grandberg, I. I. *Khim. Geterotsikl. Soedin.* **1975**, *7*, 946.

# Synthesis of polypropionate subunits from cyclopropanes

Magali Defosseux, Nicolas Blanchard, Christophe Meyer and Janine Cossy\*

Laboratoire de Chimie Organique, associé au CNRS, ESPCI, 10 rue Vauquelin, 75231 Paris Cedex 05, France

Received 29 March 2005; revised 26 May 2005; accepted 31 May 2005

Available online 22 June 2005

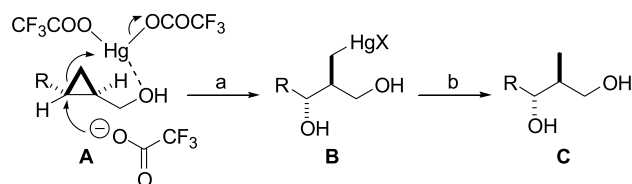
**Abstract**—The oxymercuration–reductive demercuration of several cyclopropanealkanol or their derivatives bearing adjacent stereocenters has been investigated in order to synthesize polypropionate subunits. The crucial importance of the ester protecting group for the remote oxygenated moieties on the mechanism and the stereochemical outcome of these reactions has been rationalized.

© 2005 Elsevier Ltd. All rights reserved.

## 1. Introduction

Polypropionate subunits are present in a great number of biological active natural products such as antibiotics, antitumors, antifungals, antiparasitics or immunomodulators.<sup>1</sup> The importance of these natural products together with their structural and stereochemical complexity has led to the development of several ingenious methodologies to provide access to these structures.<sup>2</sup> A widespread strategy involves the disconnection of polypropionate chains into shorter subunits bearing an alternance of methyl and hydroxyl groups and to combine these fragments by using coupling reactions.<sup>3</sup> In conjunction with our interest concerning the development of methods for polypropionate synthesis,<sup>4</sup> the generation of such subunits from cyclopropanealkanol bearing adjacent stereocenters has been investigated. Indeed, several cyclopropanealkanol of type **A** were reported to undergo highly regio- and stereoselective oxymercuration when treated with mercuric trifluoroacetate.<sup>5–9</sup> This reaction involves an electrophilic ring-opening of the cyclopropanealkanol of type **A** at the most electron-rich carbon–carbon bond with concomitant *anti* nucleophilic attack of the trifluoroacetate counter-anion (or any other added more powerful nucleophile). After hydrolysis in the presence of halide ions and subsequent reductive demercuration of the intermediate organomercuric halides of type **B**, 1,3-diols of type **C** were elaborated (Scheme 1).<sup>5–7</sup>

It is noteworthy that, a complex mixture of products was obtained when oxymercuration were applied to some



**Scheme 1.** Reagents and conditions: (a)  $\text{Hg}(\text{OCOCF}_3)_2$ ,  $\text{CH}_2\text{Cl}_2$  then  $\text{NaCl}$  ( $\text{X}=\text{Cl}$ ) or  $\text{KBr}$  ( $\text{X}=\text{Br}$ ); (b) reductive demercuration.

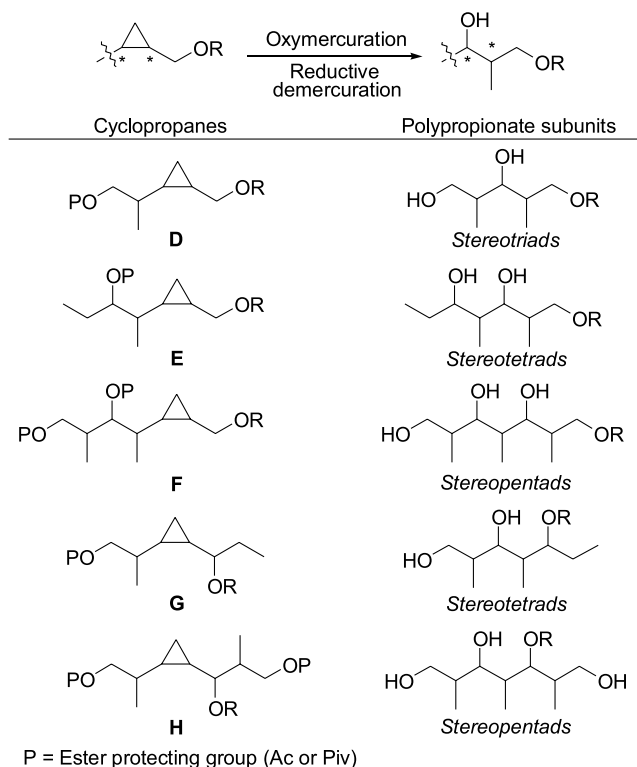
cyclopropanemethanols of type **A** bearing a remote oxygenated moiety ( $\text{R}=\text{CH}_2\text{CH}_2\text{OR}'$  with  $\text{R}'=\text{H}$  or  $\text{Si}t\text{-BuPh}_2$ ). However, the reaction proceeded in modest yield if an ester protecting group ( $\text{R}=\text{CH}_2\text{CH}_2\text{OAc}$ ) was chosen for the remote hydroxyl group, presumably due to an internal participation of the ester moiety, although, this had only been suggested and not further investigated.<sup>5</sup>

Since, the cyclopropane could be regarded as an equivalent of a methyl–hydroxyl array, whose relative configuration is controlled by the initial stereogenic centers of the three-membered ring, the oxymercuration of cyclopropanemethanol derivatives of types **D**, **E** and **F** bearing one to three adjacent stereocenters and remote hydroxyl groups protected as esters ( $\text{P}=\text{Ac}$  or  $\text{Piv}$ ) was envisaged with the aim of obtaining stereotriads, stereotetrads and stereopentads, respectively.<sup>9,10</sup> On the other hand, the oxymercuration–reductive demercuration of the secondary cyclopropanealkanol derivatives of type **G** and **H** bearing adjacent stereocenters on both sides of the three-membered ring could also provide an access to stereotetrads and stereopentads by a similar process (Scheme 2).

The preparation of racemic cyclopropanealkanol of type **D–H** was first considered in order to probe their conversion to polypropionate subunits by an oxymercuration–reductive demercuration sequence.

**Keywords:** Cyclopropanes; Diastereoselectivity; Ring opening; Electrophilic additions; Mercury.

\* Corresponding author. Tel.: +33 1 40 79 44 29; fax: +33 1 40 79 46 60; e-mail: janine.cossy@espci.fr



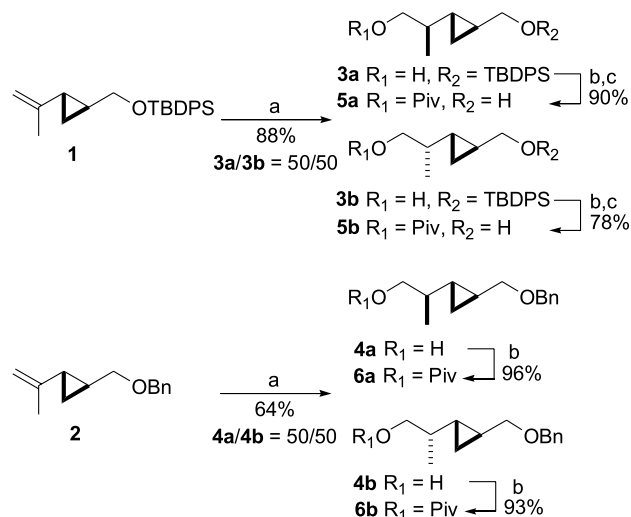
Scheme 2.

## 2. Preparation of cyclopropanemethanols of type D–H

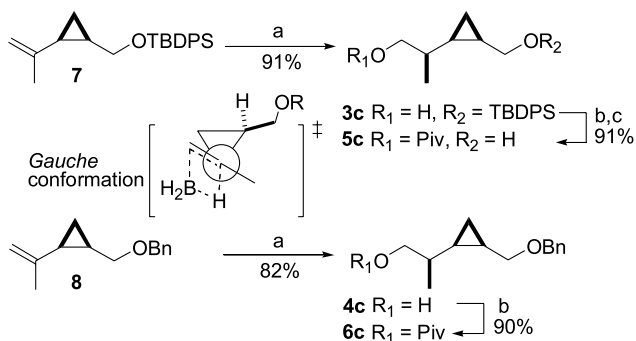
Previous investigations from our laboratory were devoted to the development of efficient synthetic routes to cyclopropanemethanols bearing adjacent stereocenters. In this context, *cis*-1,2-disubstituted alkenylcyclopropanes were reported to undergo highly diastereoselective electrophilic additions, whereas the corresponding *trans* isomers reacted in an almost stereorandom fashion.<sup>11,12</sup> Thus, when isopropenylcyclopropanes **1** and **2** were hydroborated with  $\text{BH}_3 \cdot \text{THF}$  followed by a standard alkaline oxidative work-up ( $\text{NaOH}/\text{H}_2\text{O}_2$ ), a 50/50 diastereomeric mixture of the corresponding primary alcohols **3a,b** (88%) and **4a,b** (64%), respectively, was obtained.<sup>11</sup> The diastereomers were easily separated by flash chromatography and, by standard protecting group manipulations, compounds **3a** and **3b** were converted into cyclopropanemethanols **5a** (90%) and **5b** (78%), respectively, whereas compounds **4a** and **4b** were converted into the corresponding benzyl ethers **6a** (96%) and **6b** (93%) (Scheme 3).

By contrast, the *cis*-isopropenylcyclopropanes **7** and **8**, were hydroborated with high diastereoselectivity ( $\text{dr} > 96/4$ ) to afford, respectively, the primary alcohols **3c** (91%) and **4c** (82%), having the methyl group *syn* to the adjacent cyclopropane.<sup>11</sup> This result was explained by the attack of the organoborane on the less hindered face of the double bond in the more stable and possibly reactive *gauche* conformation.<sup>12,13</sup> Compounds **3c** and **4c** were then converted to the cyclopropanemethanol **5c** (91%) or to the benzyl ether **6c** (90%) (Scheme 4).

In order to have access to a *cis*-disubstituted cyclopropanemethanol derivative with the methyl group on the



**Scheme 3.** Reagents and conditions: (a)  $\text{BH}_3 \cdot \text{THF}$ , THF,  $-30^\circ\text{C}$  to rt, then  $\text{NaOH}$ ,  $\text{H}_2\text{O}_2$ ; (b)  $\text{PivCl}$ ,  $\text{Et}_3\text{N}$  and/or  $\text{DMAP}$ ,  $\text{Et}_2\text{O}$  or  $\text{CH}_2\text{Cl}_2$ ; (c)  $n\text{-Bu}_4\text{NF}$ , THF.



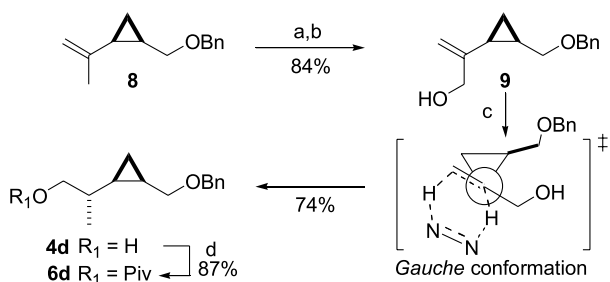
**Scheme 4.** Reagents and conditions: (a)  $\text{BH}_3 \cdot \text{THF}$ , THF,  $-30^\circ\text{C}$  to rt, then  $\text{NaOH}$ ,  $\text{H}_2\text{O}_2$ ; (b)  $\text{PivCl}$ ,  $\text{DMAP}$ ,  $\text{CH}_2\text{Cl}_2$ ; (c)  $n\text{-Bu}_4\text{NF}$ , THF.

adjacent stereocenter *anti* to the cyclopropane, the isopropenylcyclopropane **8** was first subjected to an allylic oxidation with  $\text{SeO}_2$  in the presence of *tert*-butylhydroperoxide (TBHP).<sup>14</sup> Reduction of the crude reaction mixture with sodium borohydride in the presence of cerium(III) chloride afforded the allylic alcohol **9** (84%).<sup>15</sup> By analogy with the hydroboration of **8**, the hydrogenation of the *cis*-disubstituted isopropenylcyclopropane **9** was anticipated to involve an addition to the less hindered face of the carbon–carbon double bond in the *gauche* conformation,<sup>12,13</sup> which would then stereoselectively lead to compound **4d** having the methyl group *anti* to the cyclopropane. Indeed, the reduction of **9** with diimide turned out to proceed with high diastereoselectivity ( $\text{dr} = \mathbf{4c}/\mathbf{4d} = 8/92$ ) and the resulting primary alcohol **4d** (74%) was subsequently converted to the pivalate ester **6d** (87%) (Scheme 5).

Having synthesized all the possible diastereomeric cyclopropanemethanols of type **D** **5a–5d** and their corresponding benzyl ethers **6a–6d**, the preparation of cyclopropanes of type **E** and **F**, bearing two or three stereocenters adjacent to the three-membered ring, was achieved.

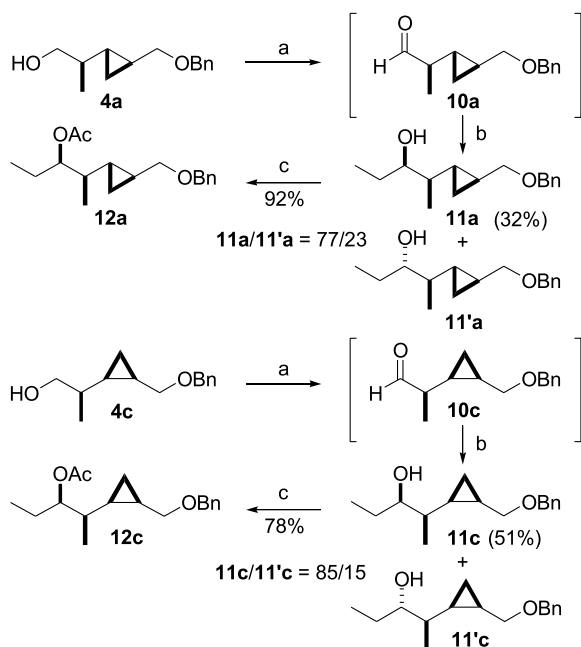
The primary alcohols **4a** and **4c** were oxidized





**Scheme 5.** Reagents and conditions: (a)  $\text{SeO}_2$ , *t*-BuOOH,  $\text{CH}_2\text{Cl}_2$ ; (b)  $\text{NaBH}_4$ ,  $\text{CeCl}_3 \cdot 7\text{H}_2\text{O}$ , MeOH, 0 °C; (c)  $\text{KO}_2\text{C}-\text{N}=\text{N}-\text{CO}_2\text{K}$ , AcOH, EtOH, 45 °C; (d) PivCl,  $\text{Et}_3\text{N}$ , cat. DMAP,  $\text{Et}_2\text{O}$ .

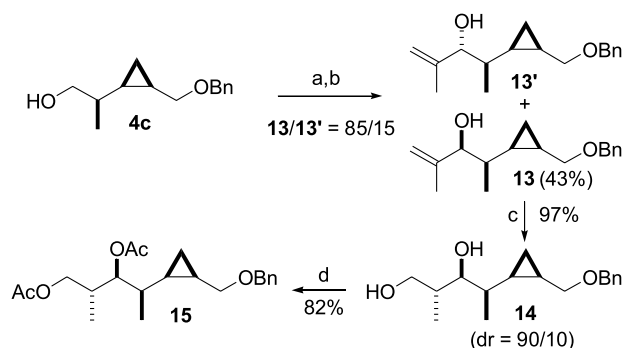
(cat. *n*-PrNRuO<sub>4</sub> (TPAP), NMO,  $\text{CH}_2\text{Cl}_2/\text{MeCN}$ )<sup>16</sup> to the corresponding sensitive aldehydes **10a** and **10c**, which were not purified but directly treated with ethylmagnesium bromide in THF, to afford diastereomeric mixtures of the corresponding secondary alcohols **11a/11'a** (dr = 77/23) and **11c/11'c** (dr = 85/15). The major diastereomers **11a** (32%) and **11c** (51%) could be separated after purification by flash chromatography and their relative configurations were initially attributed on the basis of the Felkin–Anh model for nucleophilic additions to carbonyl compounds.<sup>17</sup> This assignment was later confirmed after the oxymercuration to propylpropionate subunits. The secondary alcohols **11a** and **11c** were transformed into the acetates **12a** (92%) and **12c** (91%), respectively. They constitute two examples of cyclopropanes of type **E** (Scheme 6).



**Scheme 6.** Reagents and conditions: (a) cat. TPAP, NMO,  $\text{CH}_2\text{Cl}_2/\text{MeCN}$ , 0 °C to rt; (b)  $\text{EtMgBr}$ , THF, –30 °C and separation by flash chromatography; (c)  $\text{Ac}_2\text{O}$ , cat. DMAP,  $\text{Et}_2\text{O}$ .

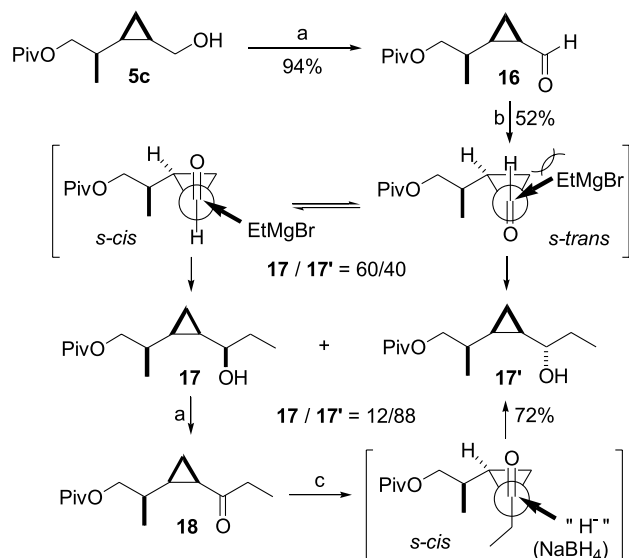
One single cyclopropane of type **F** bearing three adjacent stereocenters was synthesized from compound **4c**, which was oxidized to aldehyde **10c** and addition of isopropenylmagnesium bromide gave a diastereomeric mixture of alcohols **13** and **13'** (dr = 85/15). The major diastereomer **13** (43%) was separated and hydroborated with high

diastereoselectivity by using 9-BBN-H followed by a standard oxidative work-up to afford diol **14** (dr = 90/10, 97%),<sup>18</sup> which was finally, converted to the diacetate **15** (82%), a substrate of type **F** (Scheme 7).

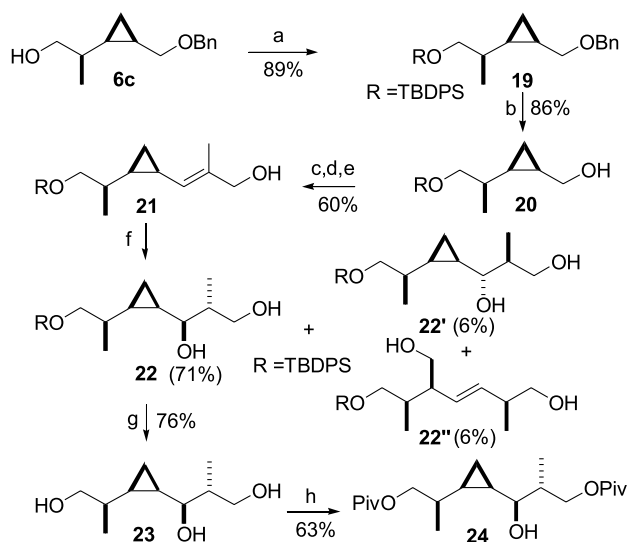


**Scheme 7.** Reagents and conditions: (a) cat. TPAP, NMO,  $\text{CH}_2\text{Cl}_2/\text{MeCN}$ , 0 °C to rt; (b) isopropenylMgBr, THF, –30 °C; (c) 9-BBN-H, THF, –30 °C to rt; (d)  $\text{Ac}_2\text{O}$ , cat. DMAP,  $\text{Et}_2\text{O}$ .

Next, the synthesis of the secondary cyclopropanemethanols of type **G** and **H** was realized. The cyclopropanemethanol **5c** was oxidized with PCC<sup>19</sup> to the corresponding cyclopropanecarboxaldehyde **16** (94%). This aldehyde **16** was treated with ethylmagnesium bromide to afford a diastereomeric mixture of the secondary cyclopropanepropionols **17** and **17'** (60/40 ratio, 52%), which were readily separated by flash chromatography. It is known that the bisected conformers of cyclopropylcarbonyl derivatives are more stable than other conformers and that they are also envisaged to be the reactive conformers in models for nucleophilic additions to this class of compounds.<sup>20</sup> For cyclopropanecarboxaldehydes, the *s-trans* conformation is only slightly preferred, whereas for cyclopropylketones the *s-cis* conformation is markedly more stable.<sup>20</sup> Moreover, nucleophilic addition to the *s-trans* conformer follows the *anti*-Felkin–Anh addition mode with respect to the carbonyl adjacent stereocenter, whereas addition to the *s-cis* conformer implies a Felkin–Anh mode.<sup>17</sup> In agreement



**Scheme 8.** Reagents and conditions: (a) PCC, 4 Å molecular sieves,  $\text{CH}_2\text{Cl}_2$ ; (b)  $\text{EtMgBr}$ , THF, –30 °C; (c)  $\text{NaBH}_4$ , MeOH, 0 °C.



**Scheme 9.** Reagents and conditions: (a) TBSCl, imidazole, DMF; (b) H<sub>2</sub>, cat. Pd/C, EtOH; (c) PCC, 4 Å molecular sieves, CH<sub>2</sub>Cl<sub>2</sub>; (d) Ph<sub>3</sub>P=CHCO<sub>2</sub>Me, toluene, reflux; (e) DIBAL-H, CH<sub>2</sub>Cl<sub>2</sub>, -78 °C; (f) *T*-hexBH<sub>2</sub>, THF, -30 °C to rt then NaOH, H<sub>2</sub>O<sub>2</sub>; (g) *n*-Bu<sub>4</sub>NF, THF; (h) PivCl, Et<sub>3</sub>N, cat. DMAP, CH<sub>2</sub>Cl<sub>2</sub>.

with these results, the addition of ethylmagnesium bromide to cyclopropanecarboxaldehyde **16** occurred with a low degree of diastereoselectivity and provided a 60/40 mixture of the secondary cyclopropanealkanol **17** and **17'** (52%), which were separated by flash chromatography. Alternatively, ketone **18** resulting from the oxidation of **17** was reduced with NaBH<sub>4</sub> in MeOH into the secondary cyclopropylpropanol **17'** with a higher diastereoselectivity of 88/12 (Scheme 8).<sup>17,20</sup>

Finally, one example of secondary cyclopropanealkanol of

type **H** was derived from substrate **4c**. This compound was protected as a *tert*-butyldiphenylsilylether **19** (89%) and subsequent debenzoylation afforded the cyclopropanemethanol **20** (86%). The latter compound was subjected to a three step sequence involving an oxidation with PCC, a Wittig olefination and subsequent reduction of the  $\alpha,\beta$ -unsaturated ester with DIBAL-H, leading to the allylic alcohol **21** (60% overall yield). Based on previous investigations, hydroboration of *cis*-1,2-disubstituted alkenylcyclopropane **21** (bearing a trisubstituted double bond) with thexylborane proceeded with high diastereoselectivity (*dr* = 12/1) giving a mixture of diols **22** and **22'**, which were separated by flash chromatography and isolated in 71 and 6% yields, respectively.<sup>11b</sup> A third minor ring-opened by-product, whose structure was assigned as **22''**, was also isolated in 6% yield.<sup>11b</sup> The major diastereomer **22** was then desilylated to generate the triol **23** (76%) and the primary alcohol moieties were protected as pivalates to afford the secondary cyclopropanealkanol **24** (63%) of type **H** (Scheme 9).

Thirteen racemic cyclopropanealkanol derivatives of type **D–H** were synthesized during the first part of this study and are reported in Table 1. Their oxymercuration–reductive demercuration was then investigated with the aim of obtaining stereotriads, stereotetrads and stereopentads.

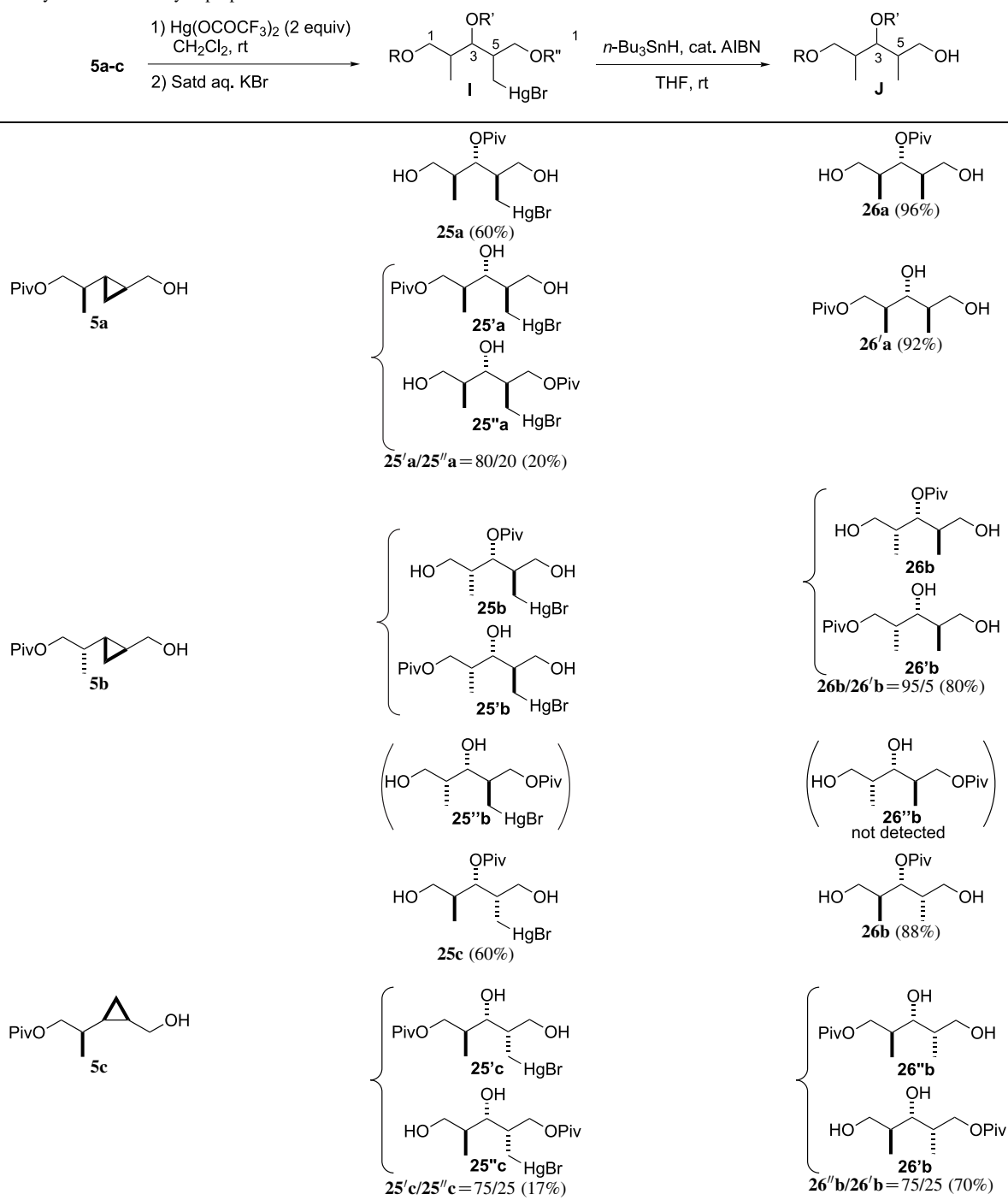
### 3. Oxymercuration of cyclopropanes of type D–F

#### 3.1. Oxymercuration of cyclopropanemethanols 5a–c

When the cyclopropanemethanols **5a–c** were subjected to an oxymercuration with mercuric trifluoroacetate (2 equiv) in CH<sub>2</sub>Cl<sub>2</sub>, a rapid reaction occurred and after treatment

**Table 1.** Structure of cyclopropanealkanol of type **D–H**

Type of structure	Cyclopropanes	
<b>D</b>	 <b>5a</b> R = H <b>6a</b> R = Bn	 <b>5c</b> R = H <b>6c</b> R = Bn
	 <b>5b</b> R = H <b>6b</b> R = Bn	 <b>6d</b> R = Bn
<b>E</b>	 <b>12a</b>	 <b>12c</b>
<b>F</b>	 <b>15</b>	
<b>G</b>	 <b>17</b>	 <b>17'</b>
<b>H</b>	 <b>24</b>	

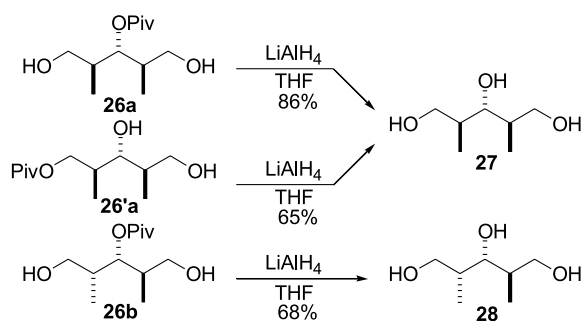
**Table 2.** Oxymercuration of cyclopropanemethanols **5a–c**

with an aqueous solution of KBr, the organomercuric bromides of type **I** were formed. These compounds have been characterized in the case of substrates **5a** and **5c**, otherwise they were directly subjected to a reductive demercuration by using  $n\text{-Bu}_3\text{SnH}$  and a catalytic amount of AIBN in THF,<sup>21</sup> to generate the stereotriads of type **J**. The results are shown in Table 2.

The oxymercuration of **5a** led to two major organomercuric bromides **25a** and **25'a** and a third minor one **25''a**, which was barely detected by analysis of the  $^1\text{H}$  NMR spectrum of the

crude reaction mixture. After careful purification by flash chromatography, **25a** was isolated in 60% yield together with an inseparable mixture of **25'a** and **25''a** (ratio 80/20, 20% yield). The reductive demercuration of **25a** afforded the symmetrical stereotriad **26'a**, whereas both compounds **25'a** and **25''a** (80/20 mixture) were converted in a similar fashion into the same stereotriad **26'a** (92%) (racemic series).<sup>22</sup>

The fact that compounds **26a** and **26'a** were reduced by  $\text{LiAlH}_4$  to the same known *anti,anti*-triol **27**,<sup>23</sup> indicated that they only differ by the positioning of the pivaloyl ester group and that the

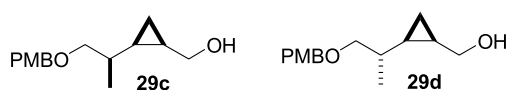


Scheme 10. Configurational assignment of compounds **26a**, **26a'** and **26b**.

organomercuric bromides **25a**, **25'a** and **25''a** all share the same relative *anti,anti* relative configuration (Scheme 10).

In the case of cyclopropanemethanol **5b**, the oxymercuration led to a regioisomeric mixture of organomercuric bromides, which was directly subjected to reductive demercuration. A regioisomeric mixture of two stereotriads **26b** and **26'b** (95/5 ratio) was obtained in 80% overall yield and in this case the third regioisomeric product **26''b** was not detected. The relative configuration of **26b** was assigned unambiguously after reduction with LiAlH<sub>4</sub> to the known *syn,anti*-triol **28**<sup>23</sup> (Scheme 10), whereas the relative configuration of **26'b** was later confirmed by a chemical correlation.<sup>22</sup> Finally, in the case of cyclopropanemethanol **5c**, the oxymercuration led to three organomercuric bromides **25c**, **25'c** and **25''c**. The major one was isolated in 60% yield, whereas an inseparable mixture of **25'c** and **25''c** (75/25 ratio) was isolated in 17% yield. The reductive demercuration of **25c** afforded the previously characterized stereotriad **26b** (88%), whereas the mixture of **25'c** and **25''c** (75/25 ratio) was converted to the stereotriads **26''b** and **26'b** (75/25 ratio), respectively, (70% combined yield).

From the results of this study, it appeared that the cyclopropanes **5a–c** of type **D**, with remote oxygenated functional groups protected as pivalates can undergo highly diastereoselective oxymercuration, which proceed with inversion of configuration at the stereocenter bearing the newly introduced oxygenated moiety (at C3). In sharp contrast, cyclopropanemethanols **29c** and **29d** having a remote oxygenated moiety protected as a 4-methoxy-benzyl ether, failed to be oxymercured under the same conditions despite extended reaction times (Fig. 1).

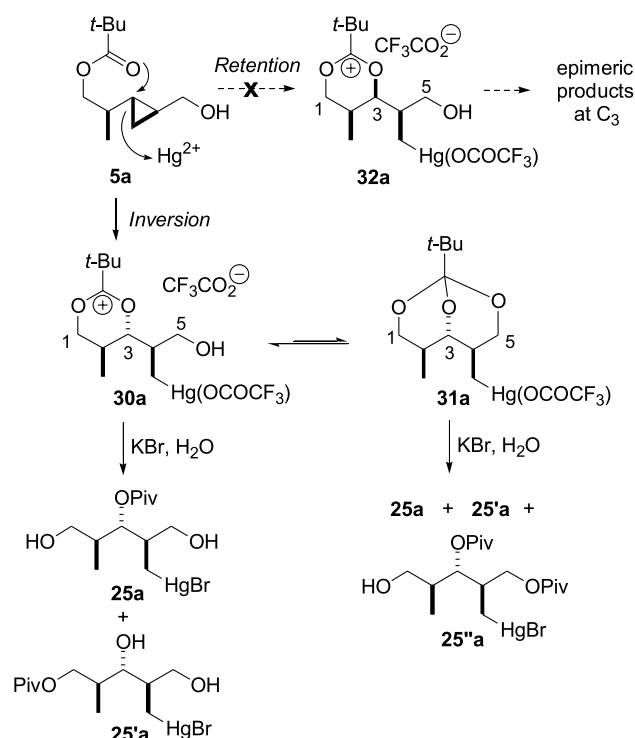


PMB = 4-methoxybenzyl

Figure 1. Structure of cyclopropanemethanols **29c** and **29d**.

All these observations clearly demonstrate the fundamental role exerted by the remote ester functionality during the mercuration of cyclopropanemethanols **5a–c**. As illustrated in the case of the cyclopropanemethanol **5a**, a reasonable scenario would involve an anchimerically assisted oxymercuration by the carbonyl group of the ester moiety,<sup>10</sup> proceeding with inversion of configuration and leading to

a dioxycarbenium ion intermediate of the type **30a**. Hydrolysis of this intermediate is expected to generate the corresponding regioisomeric organomercuric bromides **25a** and **25'a**. In order to explain the formation of the minor organomercuric bromide **25''a**, the intermediacy of a bicyclic orthoester **31a** could also be envisaged,<sup>24</sup> and its subsequent hydrolysis would generate a mixture of the three regioisomeric organomercuric bromides **25a**, **25'a** and **25''a**. Apparently, products that would have resulted from an oxymercuration proceeding with retention of configuration (hydrolysis products of intermediate **32a**) were not observed (Scheme 11).



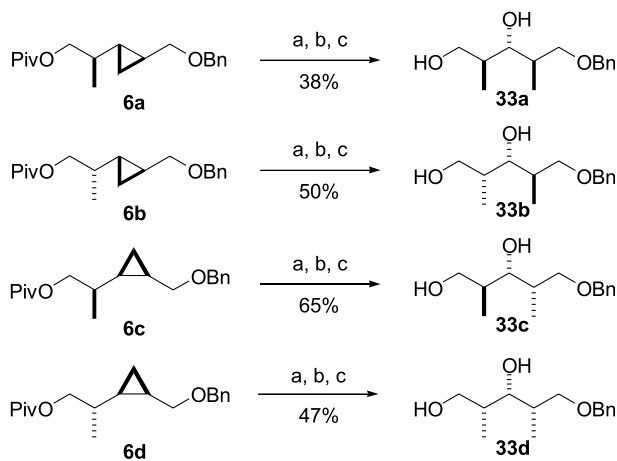
Scheme 11. Oxymercuration of cyclopropanemethanol **5a**.

Although, the possibility of synthesizing stereotriads from cyclopropanemethanols of type **D** was demonstrated, regioisomeric products were obtained from compounds **5a–c**. In order to generate stereotriads having the two primary alcohol functions differentiated, the oxymercuration–reductive demercuration of cyclopropanemethanol derivatives **6a–d** having one hydroxyl group protected as a benzyl ether and the remote hydroxyl group protected as an ester (pivalate) was investigated. Indeed, previous literature results as well as the absence of reactivity of the cyclopropanemethanols **29c** and **29d** (Fig. 1) suggested that benzyl ethers, as protecting groups, should be compatible with the oxymercuration conditions.<sup>6,8a</sup>

### 3.2. Oxymercuration of the cyclopropane derivatives **6a–d** protected as benzyl ethers

Thus, the benzyl-protected cyclopropanemethanols **6a–d** were subjected to a three-step sequence involving oxymercuration with mercuric trifluoroacetate and subsequent work-up with a saturated aqueous solution of KBr, reductive

demercuration with *n*-Bu<sub>3</sub>SnH and deprotection of the regioisomeric mixtures of pivalates with LiAlH<sub>4</sub> in THF. Although, LiAlH<sub>4</sub> itself could have initiated the reductive demercuration,<sup>21</sup> cleaner reactions were observed by using this two-step reduction procedure. Under these conditions, the known four diastereomeric stereotriads **33a–d** were, respectively, obtained from **6a–d** in 38–68% overall yields and with high diastereoselectivity (*dr* ≥ 95/5). Their relative configurations were confirmed unambiguously by comparison with literature data,<sup>25</sup> confirming that these anchimerically assisted oxymercuration proceed, as anticipated, with inversion of configuration (Scheme 12).



**Scheme 12.** Reagents and conditions: (a) Hg(OCOFCF<sub>3</sub>)<sub>2</sub>, CH<sub>2</sub>Cl<sub>2</sub> then satd aq. KBr; (b) *n*-Bu<sub>3</sub>SnH, cat. AIBN, THF; (c) LiAlH<sub>4</sub>, THF, 0 °C to rt.

The synthesis of stereotetrad and stereopentad from the structurally related cyclopropanemethanols of type **E** and **F** having primary alcohols protected as benzyl ethers and the remote oxygenated moieties protected as acetates was also investigated. The corresponding substrates **12a**, **12c** and **15** were subjected to the same three-step sequence (oxymercuration, reductive demercuration, reduction) and the results are listed in Table 3.

In the case of **12a**, the regioisomeric mixture of acetates **34a** and **34'a** (65%) was not fully characterized but reduced to produce the diol **35a** as a single diastereomer (80%). The relative configuration of this diol was determined after conversion to the acetonide **36a** by <sup>13</sup>C NMR.<sup>26</sup> In the case of **12c**, the regioisomeric acetates resulting from the oxymercuration–reductive demercuration sequence, **34c** and **34'c** (75/25 ratio, 43% combined yield) could be separated by flash chromatography. Both compounds were reduced to the same diol **35c**, whose relative configuration was determined after conversion to the acetonide **36c** (91%).<sup>26</sup> Similarly, cyclopropane **15** afforded the triol **37** (25%) after oxymercuration–reductive demercuration and subsequent reduction with LiAlH<sub>4</sub>. The triol **37**<sup>27</sup> was converted to **38** (64%) by esterification of the primary alcohol as a pivalate and formation of an acetonide, which served to confirm the configurational assignment.<sup>26</sup> In all these anchimerically assisted oxymercuration leading to stereotriads and stereopentads, an inversion of configuration was always observed at the newly introduced oxygenated moiety. Therefore, a pathway similar to the one described in Scheme 11 is likely to operate and the presence of the

**Table 3.** Synthesis of stereotetrad and stereopentad

Substrates	Products

Reagents and conditions: (a) Hg(OCOFCF<sub>3</sub>)<sub>2</sub>, CH<sub>2</sub>Cl<sub>2</sub> then satd aq. KBr; (b) *n*-Bu<sub>3</sub>SnH, cat. AIBN, THF/toluene, rt then 60 °C; (c) LiAlH<sub>4</sub>, THF; (d) 2,2-dimethoxypropane, cat. CSA, acetone; (e) PivCl, cat. DMAP, Et<sub>3</sub>N, CH<sub>2</sub>Cl<sub>2</sub>.

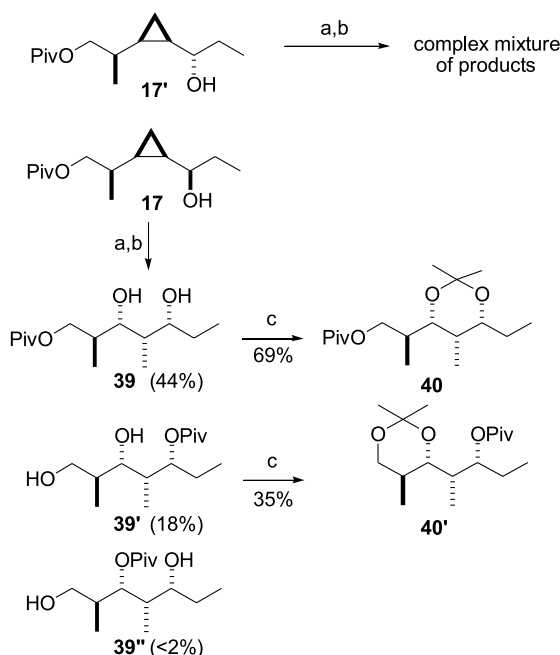
benzyl group enables the differentiation of the two primary alcohol functionalities.

The formation of stereotetrad and stereopentad from the cyclopropanemethanols **G** and **H** was next studied.

#### 4. Oxymercuration of the secondary cyclopropane-alkanols of type G–H

The oxymercuration–reductive demercuration of the two epimeric cyclopropanemethanols **17** and **17'** was first investigated in order to study the influence of the relative configuration of the secondary alcohol on the outcome of the reaction. When **17'** was subjected to the oxymercuration–reductive demercuration sequence, a complex mixture of products was formed. In sharp contrast, **17** underwent a faster and cleaner oxymercuration and after reductive demercuration two major regioisomeric diols **39** and **39'** were formed (73/27 ratio) and, respectively, isolated in 44% and 18% yields. A third minor component (<2%) whose structure was tentatively assigned to **39''** was also isolated.

The structure of **39** and **39'** was determined by NMR and the presence of a 1,3-diol moiety was supported by the fact that both compounds could be converted to the acetonides **40** and **40'**. Furthermore, examination of the  $^{13}\text{C}$  NMR spectrum of **40** enabled the assignment of its relative configuration<sup>26</sup> and confirmed that the oxymercuration had occurred with inversion of configuration at the stereocenter bearing the newly introduced oxygenated moiety (Scheme 13).

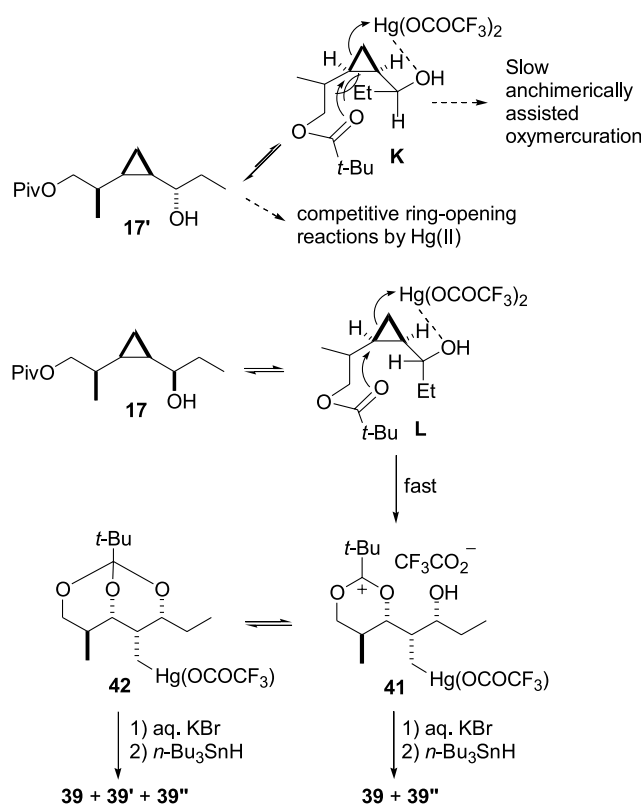


**Scheme 13.** Reagents and conditions: (a)  $\text{Hg}(\text{OCOCF}_3)_2$ ,  $\text{CH}_2\text{Cl}_2$  then satd aq.  $\text{KBr}$ ; (b)  $n\text{-Bu}_3\text{SnH}$ , cat. AIBN, THF/toluene, rt then  $60^\circ\text{C}$ ; (c) 2,2-dimethoxypropane, cat. CSA, acetone.

Although, the precise reason for the difference of reactivity between the diastereomeric cyclopropanealkanol **17** and **17'** has not been fully elucidated, it might be due to the fact that the reactive conformer **K** in the oxymercuration of **17'** is destabilized by a severe 1,3-interaction (cyclopropylic strain, similar to  $\text{A}^{1,3}$  strain),<sup>28,29</sup> thereby slowing down the intramolecularly assisted oxymercuration. This would alter the usual regioselectivity of electrophilic ring-opening of cyclopropanealkanol with mercury salts<sup>5–7</sup> and lead to competing side reactions causing the formation of a complex mixture of products.

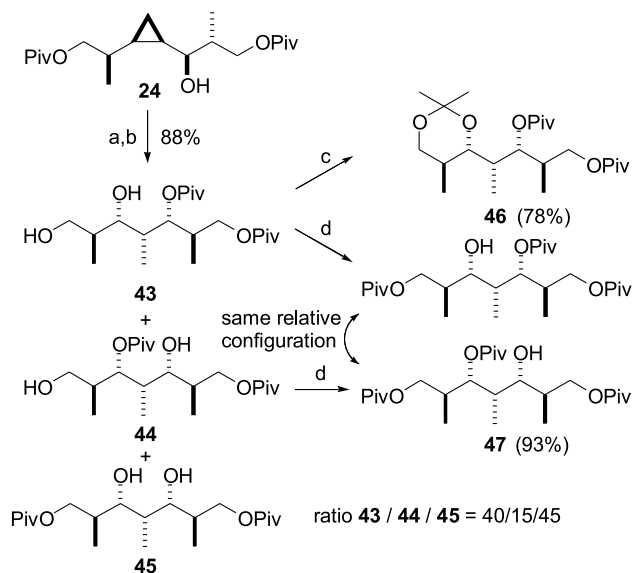
By contrast, such a 1,3-interaction is absent in conformer **L** arising from **17** and an anchimerically assisted oxymercuration by the carbonyl group of the ester would lead to a dioxycarbenium ion intermediate of the type **41**. As previously mentioned, this species could be in equilibrium with a bicyclic orthoester<sup>24</sup> **42**. Upon hydrolysis of the reaction mixture and subsequent reductive demercuration, a regioisomeric mixture of diols **39**, **39'** and **39''** is expected to be produced (Scheme 14).

Therefore, it appeared that the formation of polypropionate subunits from secondary cyclopropanealkanol was only possible for substrates having a hydroxyl group *syn* to the adjacent cyclopropane. Since, the secondary



**Scheme 14.** Oxymercuration of secondary cyclopropanealkanol **17** and **17'**.

cyclopropanealkanol **24** of type **H** met this stereochemical requirement, this compound was subjected to the oxymercuration–reductive demercuration under the standard conditions. In this case, a regioisomeric mixture of three diols **43**, **44** and **45** (45/15/40 ratio) was obtained in an excellent combined yield (88%). Due to its symmetrical character, the structure of **45** was readily assigned. Among **43** and **44**, only the latter could be converted to the acetonide **46**, thereby establishing the presence of a 1,3-diol moiety in this



**Scheme 15.** Reagents and conditions: (a)  $\text{Hg}(\text{OCOCF}_3)_2$ ,  $\text{CH}_2\text{Cl}_2$ , rt then satd aq.  $\text{KBr}$ ; (b)  $n\text{-Bu}_3\text{SnH}$ , cat. AIBN, THF/toluene, rt then  $60^\circ\text{C}$ ; (c) 2,2-dimethoxypropane, cat. CSA, acetone; (d)  $\text{PivCl}$ , cat. DMAP,  $\text{Et}_3\text{N}$ ,  $\text{Et}_2\text{O}$ .

compound. Moreover, monoesterification of a mixture of **43** and **44** by treatment with PivCl led to a single compound **47** (93%) due to the formation of a diastereomer of similar relative configuration (racemic series). These results demonstrated once again that **43**, **44** and **45** only differ by the positioning of one pivalate group and that the oxymercuration has involved, like in all cases investigated, an inversion of configuration. Moreover, the further remote second pivalate moiety in cyclopropylcarbinol **24** has not interfered in the oxymercuration reaction (Scheme 15).

## 5. Conclusion

We have reported a full account of our studies concerning the synthesis of polypropionate-type subunits from cyclopropanes bearing adjacent stereocenters using an oxymercuration–reductive demercuration sequence. The presence of a suitably located ester protecting group for the hydroxyl group at the  $\beta$ -position was found to be crucial due to a favorable anchimeric assistance in the oxymercuration process. Although, the use of mercury salts restricts the interest of these reactions to academic research activities, the results presented in this account should encourage the search for alternative mediators to effect these transformations, as the cyclopropane could be regarded as a useful synthetic equivalent of a methyl-hydroxyl array. Moreover, the stereoelectronic properties of the three-membered ring can be used to control the configurations of adjacent stereocenters as illustrated by stereoselective electrophilic additions to alkenylcyclopropanes or nucleophilic additions to cyclopropylcarbonyl derivatives.

## 6. Experimental

### 6.1. General procedures

Infrared (IR) spectra were recorded on a Perkin–Elmer 298, wavenumbers are indicated in  $\text{cm}^{-1}$ .  $^1\text{H}$  NMR spectra were recorded on a Bruker AC 300 at 300 MHz in  $\text{CDCl}_3$  (unless otherwise specified) and data are reported as follows: chemical shift in ppm from tetramethylsilane as an internal standard, multiplicity (s=singlet, d=doublet, t=triplet, q=quartet, m=multiplet or overlap of non-equivalent resonances), integration.  $^{13}\text{C}$  NMR spectra were recorded on a Bruker AC 300 at 75 MHz in  $\text{CDCl}_3$  and data are reported as follows: chemical shift in ppm from tetramethylsilane with the solvent as an internal indicator ( $\text{CDCl}_3$   $\delta$  77.0 ppm), multiplicity with respect to proton (deduced from DEPT experiments, s=quaternary C, d=CH, t= $\text{CH}_2$ , q= $\text{CH}_3$ ). Mass spectra with electronic impact (MS-EI) were recorded from a Hewlett-Packard tandem 5890A GC (12 m capillary column)–5971 MS (70 eV). Mass spectra with chemical ionization (MS- $\text{CI}^+$ ) or FAB and high resolution mass spectra (HRMS) were performed by the Centre de Spectrochimie Organique de l'École Normale Supérieure Ulm (Paris). Elemental analyses were performed by the Centre Régional de Microanalyses (Université Pierre et Marie Curie, Paris VI). THF and diethyl ether were distilled from sodium/benzophenone.  $\text{CH}_2\text{Cl}_2$ ,  $\text{CH}_3\text{CN}$ , toluene,  $\text{Et}_3\text{N}$ , DMF were distilled from  $\text{CaH}_2$ . Other reagents were obtained from commercial suppliers and

used as received. TLC was performed on Merck 60F<sub>254</sub> silica gel plates visualized either with a UV lamp (254 nm), or by using solutions of *p*-anisaldehyde/ $\text{H}_2\text{SO}_4$ / $\text{AcOH}$  in EtOH or  $\text{KMnO}_4/\text{K}_2\text{CO}_3$  in water followed by heating. Flash chromatography was performed with SDS 60 silica gel (230–400 mesh).

### 6.2. Preparation of cyclopropanes of type D

**6.2.1. (2R\*)-2-[(1S\*,2S\*)-2-(Hydroxymethyl)cyclopropyl]propyl 2,2-dimethylpropanoate 5a.** To a solution of **3a**<sup>10,11</sup> (500 mg, 1.36 mmol) in  $\text{Et}_2\text{O}$  (10 mL) at rt, were successively added  $\text{Et}_3\text{N}$  (265  $\mu\text{L}$ , 1.90 mmol, 1.4 equiv), DMAP (33 mg, 0.27 mol, 0.2 equiv) and PivCl (236  $\mu\text{L}$ , 1.90 mmol, 1.4 equiv). After 12 h, the reaction was quenched by addition of a saturated aqueous  $\text{NaHCO}_3$  solution and the resulting mixture was extracted with  $\text{Et}_2\text{O}$ . The combined extracts were washed with a 1 M aqueous HCl solution, brine, dried over  $\text{MgSO}_4$ , filtered and concentrated under reduced pressure. The residual oil was dissolved in THF (5 mL) and to the resulting solution at 0 °C, was added *n*- $\text{Bu}_4\text{NF}$  (2.0 mL, 1 M in THF, 2.0 mmol). After 3 h at rt, the reaction mixture was hydrolyzed with a saturated aqueous  $\text{NH}_4\text{Cl}$  solution and extracted with  $\text{Et}_2\text{O}$ . The combined extracts were dried over  $\text{MgSO}_4$ , filtered and concentrated under reduced pressure. The residue was purified by flash chromatography (cyclohexane– $\text{EtOAc}$ : 90/10–75/25) to afford 261 mg (90%) of **5a** as a colorless oil; IR 3450, 1725, 1285, 1165, 1035  $\text{cm}^{-1}$ ;  $^1\text{H}$  NMR  $\delta$  4.09 (dd,  $J=10.7, 5.9$  Hz, 1H), 3.91 (dd,  $J=10.7, 6.7$  Hz, 1H), 3.49 (dd,  $J=11.2, 6.9$  Hz, 1H), 3.42 (dd,  $J=11.2, 7.1$  Hz, 1H), 2.31 (br s, 1H, OH), 1.20 (m, 1H), 1.20 (s, 9H), 1.02 (d,  $J=6.8$  Hz, 3H), 0.91 (m, 1H), 0.53–0.41 (m, 3H);  $^{13}\text{C}$  NMR  $\delta$  178.7 (s), 68.8 (t), 66.6 (t), 38.7 (s), 37.6 (d), 27.0 (q, 3C), 21.0 (d), 20.4 (d), 16.4 (q), 8.3 (t); MS-EI  $m/z$  (relative intensity) 197 ( $\text{M}-\text{OH}^+$ , 2), 183 ( $\text{M}-\text{CH}_2\text{OH}^+$ , 2), 112 ( $\text{M}-t\text{-BuCO}_2\text{H}^+$ , 13), 97 (14), 95 (15), 85 (19), 81 (16), 79 (18), 69 (18), 68 (18), 57 (100), 55 (17).

**6.2.2. (2S\*)-2-[(1S\*,2S\*)-2-(Hydroxymethyl)cyclopropyl]propyl 2,2-dimethylpropanoate 5b.** This compound was synthesized from **3b**<sup>10,11</sup> (500 mg, 1.36 mmol), following the procedure described for the preparation of **5a** from **3a**. Purification by flash chromatography (cyclohexane– $\text{EtOAc}$ : 90/10–75/25) afforded 227 mg (78%) of **5b** as a colorless oil; IR 3400, 1720, 1290, 1165, 1030  $\text{cm}^{-1}$ ;  $^1\text{H}$  NMR  $\delta$  4.10 (dd,  $J=10.7, 5.9$  Hz, 1H), 3.90 (dd,  $J=10.7, 6.7$  Hz, 1H), 3.48 (dd,  $J=11.2, 6.9$  Hz, 1H), 3.42 (dd,  $J=11.2, 7.1$  Hz, 1H), 2.30 (br s, 1H, OH), 1.28–1.14 (m, 2H), 1.21 (s, 9H), 1.02 (d,  $J=6.8$  Hz, 3H), 0.53–0.41 (m, 3H);  $^{13}\text{C}$  NMR  $\delta$  178.6 (s), 69.0 (t), 66.8 (t), 38.8 (s), 37.0 (d), 27.2 (q, 3C), 20.8 (d), 19.5 (d), 16.6 (q), 9.3 (t); MS-EI  $m/z$  (relative intensity) 197 ( $\text{M}-\text{OH}^+$ , 7), 183 ( $\text{M}-\text{CH}_2\text{OH}^+$ , 4), 112 ( $\text{M}-t\text{-BuCO}_2\text{H}^+$ , 14), 97 (19), 95 (19), 85 (20), 81 (15), 79 (20), 69 (16), 68 (18), 57 (100), 55 (18).

**6.2.3. (2R\*)-2-[(1S\*,2R\*)-2-(Hydroxymethyl)cyclopropyl]propyl 2,2-dimethylpropanoate 5c.** This compound was prepared from **3c**<sup>10,11</sup> (1.28 g, 3.47 mmol) following the procedure described for the preparation of **5a** from **3a**. Purification by flash chromatography (pentane– $\text{Et}_2\text{O}$ : 60/40–50/50) afforded 676 mg (91%) of **5c** as a

colorless oil; IR 3420, 1725, 1290, 1160, 1035  $\text{cm}^{-1}$ ;  $^1\text{H}$  NMR  $\delta$  4.28 (dd,  $J=10.8$ , 4.0 Hz, 1H), 3.78 (dd,  $J=10.8$ , 8.3 Hz, 1H), 3.76 (m, 1H), 3.46 (m, 1H), 2.81 (br s, 1H, OH), 1.36 (m, 1H), 1.18 (m, 1H), 1.16 (s, 9H), 1.04 (d,  $J=6.7$  Hz, 3H), 0.72–0.58 (m, 2H),  $-0.06$  (m, 1H);  $^{13}\text{C}$  NMR  $\delta$  179.1 (s), 69.7 (t), 62.7 (t), 38.8 (s), 32.6 (d), 27.1 (q, 3C), 19.7 (d), 18.8 (d), 17.9 (q), 7.6 (t); MS-EI  $m/z$  (relative intensity) 197 ( $\text{M}-\text{OH}^+$ , 3), 183 ( $\text{M}-\text{CH}_2\text{OH}^+$ , 3), 112 ( $\text{M}-t\text{-BuCO}_2\text{H}^+$ , 14), 97 (17), 95 (17), 85 (21), 81 (16), 79 (20), 69 (18), 68 (16), 57 (100), 55 (16).

**6.2.4. (2R\*)-2-((1R\*,2S\*)-2-[(Benzyloxy)methyl]cyclopropyl)propan-1-ol 4a and (2S\*)-2-((1R\*,2S\*)-2-[(benzyloxy)methyl]cyclopropyl)propan-1-ol 4b.**<sup>10,11</sup> To a solution of **2** (340 mg, 1.68 mmol) in THF (5 mL) at  $-30^\circ\text{C}$ , was added  $\text{BH}_3\cdot\text{THF}$  (1.7 mL, 1 M in THF, 1.7 mmol, 1.0 equiv) and the reaction mixture was allowed to warm to rt for 1 h. After 1 h, a 6 M aqueous solution of NaOH (5 mL) and a 30% aqueous  $\text{H}_2\text{O}_2$  solution (5 mL) were successively added dropwise at  $0^\circ\text{C}$ . After 3 h at rt, the resulting mixture was extracted with  $\text{Et}_2\text{O}$  and the combined extracts were washed with brine, dried over  $\text{MgSO}_4$ , filtered and concentrated under reduced pressure. The residue was purified by flash chromatography (cyclohexane–EtOAc: 80/20) to afford 144 mg (39%) of **4a** and 92 mg (25%) of **4b** as colorless oils.

**Compound (4a).**  $R_f$  0.42 (cyclohexane–EtOAc: 50/50); IR 3430, 1095, 1070, 1030  $\text{cm}^{-1}$ ;  $^1\text{H}$  NMR  $\delta$  7.38–7.23 (m, 5H), 4.55 (d,  $J=12.2$  Hz, 1H), 4.47 (d,  $J=12.2$  Hz, 1H), 3.73 (dd,  $J=9.5$ , 5.3 Hz, 1H), 3.62–3.46 (m, 2H), 3.25 (br s, 1H, OH), 2.86 (dd apparent t,  $J=9.5$  Hz, 1H), 1.14–0.94 (m, 3H), 0.90 (d,  $J=6.4$  Hz, 3H), 0.40–0.28 (m, 2H);  $^{13}\text{C}$  NMR  $\delta$  138.1 (s), 128.3 (d, 2C), 127.5 (d), 127.4 (d, 2C), 74.3 (t), 72.7 (t), 69.1 (t), 40.0 (d), 21.7 (d), 18.1 (d), 16.4 (q), 7.1 (t); MS-EI  $m/z$  (relative intensity) 161 ( $\text{M}-\text{CH}_3\text{CHCH}_2\text{OH}^+$ , 4), 108 (11), 107 (13), 92 (15), 91 (100), 82 (10).

**Compound (4b).**  $R_f$  0.22 (cyclohexane–EtOAc: 50/50); IR 3400, 3080, 1090, 1070, 1030  $\text{cm}^{-1}$ ;  $^1\text{H}$  NMR  $\delta$  7.40–7.24 (m, 5H), 4.55 (d,  $J=12.1$  Hz, 1H), 4.50 (d,  $J=12.1$  Hz, 1H), 3.54 (d,  $J=5.9$  Hz, 2H), 3.40 (dd,  $J=10.0$ , 6.6 Hz, 1H), 3.24 (dd,  $J=10.0$ , 7.4 Hz, 1H), 2.16 (br s, 1H, OH), 1.24 (m, 1H), 0.93 (m, 1H), 0.92 (d,  $J=6.8$  Hz, 3H), 0.55–0.49 (m, 2H), 0.42 (m, 1H);  $^{13}\text{C}$  NMR  $\delta$  138.4 (s), 128.3 (d, 2C), 127.5 (d, 2C), 127.4 (d), 74.2 (t), 72.4 (t), 68.3 (t), 38.6 (d), 20.3 (d), 15.4 (q), 15.3 (d), 9.0 (t); MS-EI  $m/z$  (relative intensity) 161 ( $\text{M}-\text{CH}_3\text{CHCH}_2\text{OH}^+$ , 3), 108 (12), 92 (15), 91 (100), 82 (10).

**6.2.5. (2R\*)-2-((1S\*,2S\*)-2-[(Benzyloxy)methyl]cyclopropyl)propyl 2,2-dimethylpropanoate 6a.** To a solution of **4a** (460 mg, 2.09 mmol) and DMAP (383 mg, 3.13 mmol, 1.5 equiv) in  $\text{CH}_2\text{Cl}_2$  (10 mL) at rt, was added PivCl (310  $\mu\text{L}$ , 2.50 mmol, 1.2 equiv). After 2 h, the reaction was quenched with MeOH (1 mL). After 20 min, a saturated aqueous  $\text{NaHCO}_3$  solution was added and the resulting mixture was extracted with  $\text{Et}_2\text{O}$ . The combined extracts were dried over  $\text{MgSO}_4$ , filtered and concentrated under reduced pressure. The residue was purified by flash chromatography (cyclohexane–EtOAc: 95/5) to afford 614 mg (96%) of **6a** as a colorless oil; IR 3060, 1725, 1480, 1290, 1160, 1095  $\text{cm}^{-1}$ ;  $^1\text{H}$  NMR  $\delta$  7.36–7.23 (m,

5H), 4.50 (s, 2H), 4.07 (dd,  $J=10.8$ , 5.5 Hz, 1H), 3.95 (dd,  $J=10.8$ , 6.8 Hz, 1H), 3.45 (dd,  $J=10.1$ , 6.1 Hz, 1H), 3.16 (dd,  $J=10.1$ , 7.5 Hz, 1H), 1.19 (m, 1H), 1.19 (s, 9H), 0.98 (d,  $J=6.6$  Hz, 3H), 0.98 (m, 1H), 0.54–0.36 (m, 3H);  $^{13}\text{C}$  NMR  $\delta$  178.4 (s), 138.5 (s), 128.3 (d, 2C), 127.5 (d, 2C), 127.4 (d), 73.7 (t), 72.4 (t), 69.1 (t), 38.7 (s), 37.2 (d), 27.2 (q, 3C), 20.5 (d), 17.5 (d), 16.5 (q), 8.9 (t); MS-EI  $m/z$  (relative intensity) 213 ( $\text{M}-\text{CH}_2\text{Ph}^+$ , 1), 96 (22), 95 (17), 92 (12), 91 (100), 81 (16), 57 (37). Anal. Calcd for  $\text{C}_{19}\text{H}_{28}\text{O}_3$ : C, 74.96; H, 9.27. Found: C, 74.81; H, 9.37.

**6.2.6. (2S\*)-2-((1S\*,2S\*)-2-[(Benzyloxy)methyl]cyclopropyl)propyl 2,2-dimethylpropanoate 6b.** This compound was synthesized from **4b** (100 mg, 0.44 mmol) following the procedure described for the preparation of **6a** from **4a**. Purification by flash chromatography (cyclohexane–EtOAc: 95/5) afforded 129 mg (93%) of **6b** as a colorless oil; IR 3060, 1730, 1285, 1165, 1100  $\text{cm}^{-1}$ ;  $^1\text{H}$  NMR  $\delta$  7.35–7.25 (m, 5H), 4.56 (d,  $J=12.0$  Hz, 1H), 4.49 (d,  $J=12.0$  Hz, 1H), 4.07 (dd,  $J=10.8$ , 5.5 Hz, 1H), 3.90 (dd,  $J=10.8$ , 6.8 Hz, 1H), 3.38 (dd,  $J=10.3$ , 6.6 Hz, 1H), 3.27 (dd,  $J=10.3$ , 7.0 Hz, 1H), 1.21 (m, 1H), 1.20 (s, 9H), 1.04 (d,  $J=6.6$  Hz, 3H), 0.93 (m, 1H), 0.52–0.39 (m, 3H);  $^{13}\text{C}$  NMR  $\delta$  178.5 (s), 138.6 (s), 128.3 (d, 2C), 127.5 (d, 2C), 127.4 (d), 74.0 (t), 72.4 (t), 69.0 (t), 38.8 (s), 37.3 (d), 27.2 (q, 3C), 20.8 (d), 16.8 (q), 16.7 (d), 9.8 (t); MS-EI  $m/z$  (relative intensity) 304 ( $\text{M}^+$ , 1), 247 ( $\text{M}-t\text{-Bu}^+$ , 1), 197 (15), 96 (11), 95 (21), 92 (13), 91 (100), 57 (37). Anal. Calcd for  $\text{C}_{19}\text{H}_{28}\text{O}_3$ : C, 74.96; H, 9.27. Found: C, 74.82; H, 9.42.

**6.2.7. (2R\*)-2-((1R\*,2R\*)-2-[(Benzyloxy)methyl]cyclopropyl)propan-1-ol 4c.** To a solution of **8** (5.68 g, 28.1 mmol) in THF (300 mL) at  $-30^\circ\text{C}$ , was added  $\text{BH}_3\cdot\text{THF}$  complex (32 mL, 1 M in THF, 32 mmol, 1.1 equiv) and the reaction mixture was allowed to warm to rt for 1 h. After 2 h, a 3 M aqueous NaOH solution (70 mL) and a 30% aqueous  $\text{H}_2\text{O}_2$  solution (70 mL) were successively added dropwise at  $0^\circ\text{C}$ . After 3 h at rt, the aqueous phase was extracted with  $\text{Et}_2\text{O}$ , the combined extracts were washed with brine, dried over  $\text{MgSO}_4$ , filtered and concentrated under reduced pressure. The residue was purified by flash chromatography (petroleum ether–EtOAc gradient: 90/10–70/30) to afford 5.04 g (82%) of **4c** as a colorless oil; IR 3420, 3060, 1090, 1070  $\text{cm}^{-1}$ ;  $^1\text{H}$  NMR  $\delta$  7.40–7.24 (m, 5H), 4.51 (s, 2H), 3.80 (br s, 1H, OH), 3.80 (dd,  $J=10.4$ , 5.1 Hz, 1H), 3.57 (dd,  $J=10.4$ , 4.5 Hz, 1H), 3.43 (dd apparent t,  $J=10.0$  Hz, 1H), 3.11 (dd apparent t,  $J=10.0$  Hz, 1H), 1.34–1.18 (m, 2H), 0.96 (d,  $J=6.8$  Hz, 3H), 0.73–0.59 (m, 2H),  $-0.11$  (m, 1H);  $^{13}\text{C}$  NMR  $\delta$  137.4 (s), 128.3 (d, 2C), 127.8 (d, 2C), 127.7 (d), 72.9 (t), 70.4 (t), 68.8 (t), 35.1 (d), 21.1 (d), 17.7 (q), 16.2 (d), 6.3 (t); MS-EI  $m/z$  (relative intensity) 143 ( $\text{M}-\text{Ph}^+$ , 2), 108 (9), 107 (11), 92 (15), 91 (100), 82 (9), 81 (10), 67 (10), 55 (9). Anal. Calcd for  $\text{C}_{14}\text{H}_{20}\text{O}_2$ : C, 76.33; H, 9.15. Found: C, 76.14; H, 9.37.

**6.2.8. (2R\*)-2-((1S\*,2R\*)-2-[(Benzyloxy)methyl]cyclopropyl)propyl 2,2-dimethylpropanoate 6c.** This compound was synthesized from **4c** (140 mg, 0.636 mmol) following the procedure described for the preparation of **6a** from **4a**. Purification by flash chromatography (cyclohexane–EtOAc: 95/5) afforded 172 mg (90%) of **6c** as a colorless oil; IR 3060, 1725, 1285, 1165  $\text{cm}^{-1}$ ;  $^1\text{H}$  NMR  $\delta$



7.26–7.15 (m, 5H), 4.47 (d,  $J=11.8$  Hz, 1H), 4.42 (d,  $J=11.8$  Hz, 1H), 4.17 (dd,  $J=10.6, 4.1$  Hz, 1H), 3.82 (dd,  $J=10.6, 8.1$  Hz, 1H), 3.45 (dd,  $J=10.1, 6.9$  Hz, 1H), 3.39 (dd,  $J=10.1, 7.9$  Hz, 1H), 1.31 (m, 1H), 1.17 (s, 9H), 1.13 (m, 1H), 0.97 (d,  $J=6.7$  Hz, 3H), 0.77–0.64 (m, 2H), –0.04 (m, 1H);  $^{13}\text{C}$  NMR  $\delta$  178.4 (s), 138.4 (s), 128.3 (d, 2C), 127.8 (d, 2C), 127.5 (d), 72.8 (t), 70.5 (t), 69.1 (t), 38.8 (s), 32.8 (d), 27.2 (q, 3C), 19.7 (d), 17.6 (q), 16.1 (d), 8.3 (t); MS-EI  $m/z$  (relative intensity) 219 ( $\text{M}-t\text{-BuCO}^+$ , 1), 213 ( $\text{M}-\text{CH}_2\text{Ph}^+$ , 1), 96 (25), 95 (16), 92 (12), 91 (100), 81 (19), 57 (40). Anal. Calcd for  $\text{C}_{19}\text{H}_{28}\text{O}_3$ : C, 74.96; H, 9.27. Found: C, 74.81; H, 9.39.

**6.2.9. 2-((1*S*\*,2*R*\*)-2-((Benzyloxy)methyl)cyclopropyl)prop-2-en-1-ol 9.** To a solution of  $\text{SeO}_2$  (28 mg, 0.25 mmol, 0.5 equiv) in  $\text{CH}_2\text{Cl}_2$  (10 mL) at 0 °C, was added  $t\text{-BuOOH}$  (370  $\mu\text{L}$ , ca. 5.5 M in decane, 2.04 mmol, 4.0 equiv). After 30 min, a solution of **8** (103 mg, 0.509 mmol) in  $\text{CH}_2\text{Cl}_2$  (5 mL) was added dropwise and the reaction mixture was allowed to warm to rt. After 7 h, the reaction mixture was hydrolyzed with a 1 M aqueous NaOH solution and extracted with  $\text{CH}_2\text{Cl}_2$ . The combined extracts were washed with brine, dried over  $\text{MgSO}_4$ , filtered and concentrated under reduced pressure. The residue was dissolved in MeOH (5 mL) and to the resulting solution at 0 °C, were successively added  $\text{CeCl}_3 \cdot 7\text{H}_2\text{O}$  (190 mg, 0.509 mmol, 1.0 equiv) and  $\text{NaBH}_4$  (38 mg, 1.0 mmol, 2.0 equiv). After 20 min, the reaction mixture was poured into a saturated aqueous  $\text{NH}_4\text{Cl}$  solution and extracted with  $\text{Et}_2\text{O}$ . The combined extracts were washed with brine, dried over  $\text{MgSO}_4$ , filtered and concentrated under reduced pressure. The residue was purified by flash chromatography (petroleum ether– $\text{EtOAc}$ : 80/20–70/30) to afford 93 mg (84%) of **9** as a colorless oil; IR 3400, 3060, 1645, 1060, 1030, 905, 740, 700  $\text{cm}^{-1}$ ;  $^1\text{H}$  NMR  $\delta$  7.30–7.16 (m, 5H), 4.93 (br s, 1H), 4.56 (br s, 1H), 4.41 (d,  $J=11.9$  Hz, 1H), 4.34 (d,  $J=11.9$  Hz, 1H), 4.10 (br s, 2H), 3.60 (dd,  $J=10.0, 4.5$  Hz, 1H), 3.50 (br s, 1H, OH), 2.89 (dd, apparent t,  $J=10.0$  Hz, 1H), 1.54 (m, 1H), 1.40 (m, 1H), 0.71 (m, 1H), 0.45 (m, 1H);  $^{13}\text{C}$  NMR  $\delta$  145.6 (s), 137.3 (s), 128.3 (d, 2C), 127.9 (d, 2C), 127.7 (d), 110.7 (t), 72.9 (t), 68.6 (t), 67.5 (t), 18.9 (d), 17.4 (d), 5.1 (t); MS ( $\text{Cl}^+$ ,  $\text{CH}_4$ )  $m/z$  (relative intensity) 219 ( $\text{M}+\text{H}^+$ , 50), 201 (15), 183 (45), 171 (16), 129 (17), 111 (40), 93 (82), 91 (100); HRMS ( $\text{Cl}^+$ ,  $\text{CH}_4$ ) Calcd for  $\text{C}_{14}\text{H}_{19}\text{O}_2$  ( $\text{M}+\text{H}^+$ ): 219.1385. Found: 219.1381.

**6.2.10. (2*S*\*)-2-((1*R*\*,2*R*\*)-2-((Benzyloxy)methyl)cyclopropyl)propan-1-ol 4d.** A solution of AcOH (7.5 g, 0.12 mol) in EtOH (20 mL) was added over 8 h, via a syringe pump, to a solution of **9** (86 mg, 0.39 mmol) and potassium azodicarboxylate ( $2 \times 24$  g added at 4 h interval, 0.24 mol) in EtOH (60 mL) at 45 °C. After a further 1 h at 40 °C, the reaction mixture was cooled to rt and filtered through Celite. The filtrate was evaporated under reduced pressure and the solid residue was triturated in  $\text{Et}_2\text{O}$  (300 mL). The resulting mixture was stirred overnight at rt, filtered through Celite and the insoluble material was thoroughly washed with  $\text{Et}_2\text{O}$ . The filtrate was evaporated under reduced pressure and the crude material was analyzed by  $^1\text{H}$  NMR and GC–MS, which indicated the formation of a diastereomeric mixture of **4c** and **4d** (8/92 ratio). Purification by flash chromatography (cyclohexane– $\text{EtOAc}$ : 75/25) afforded 64 mg (74%) of **4d** as a colorless

oil; IR 3380, 3060, 1090, 1070, 1020, 750, 740, 700  $\text{cm}^{-1}$ ;  $^1\text{H}$  NMR  $\delta$  7.37–7.27 (m, 5H), 4.57 (d,  $J=11.9$  Hz, 1H), 4.51 (d,  $J=11.9$  Hz, 1H), 3.64 (dd,  $J=10.7, 5.7$  Hz, 1H), 3.53 (dd,  $J=10.3, 6.6$  Hz, 1H), 3.52 (dd,  $J=10.7, 6.2$  Hz, 1H), 3.44 (dd,  $J=10.3, 8.0$  Hz, 1H), 1.77 (br s, 1H, OH), 1.27–1.14 (m, 2H), 1.08 (d,  $J=6.3$  Hz, 3H), 0.81–0.62 (m, 2H), 0.13 (m, 1H);  $^{13}\text{C}$  NMR  $\delta$  138.4 (s), 128.3 (d, 2C), 127.7 (d, 2C), 127.5 (d), 72.8 (t), 70.3 (t), 68.9 (t), 35.9 (d), 19.7 (d), 17.3 (q), 14.0 (d), 8.5 (t); MS ( $\text{Cl}^+$ ,  $\text{CH}_4$ )  $m/z$  (relative intensity) 221 ( $\text{M}+\text{H}^+$ , 17), 123 (37), 113 (51), 95 (100), 91 (100). Anal. Calcd for  $\text{C}_{14}\text{H}_{20}\text{O}_2$ : C, 76.33; H, 9.15. Found: C, 76.03; H, 9.46.

**6.2.11. (2*S*\*)-2-((1*S*\*,2*R*\*)-2-((Benzyloxy)methyl)cyclopropyl)propyl 2,2-dimethylpropanoate 6d.** This compound was synthesized from **4d** (50 mg, 0.23 mmol) following the procedure described for the preparation of **6c** from **4c**. Purification by flash chromatography (petroleum ether– $\text{EtOAc}$ : 95/5) gave 59 mg (87%) of **6d** as a colorless oil; IR 3070, 1730, 1290, 1165, 1090  $\text{cm}^{-1}$ ;  $^1\text{H}$  NMR  $\delta$  7.35–7.25 (m, 5H), 4.56 (d,  $J=12.0$  Hz, 1H), 4.49 (d,  $J=12.0$  Hz, 1H), 4.09 (dd,  $J=10.7, 5.5$  Hz, 1H), 3.91 (dd,  $J=10.7, 7.0$  Hz, 1H), 3.54 (dd,  $J=10.3, 6.3$  Hz, 1H), 3.40 (dd,  $J=10.3, 8.1$  Hz, 1H), 1.42–1.14 (m, 2H), 1.20 (s, 9H), 1.09 (d,  $J=6.6$  Hz, 3H), 0.78–0.64 (m, 2H), 0.10 (m, 1H);  $^{13}\text{C}$  NMR  $\delta$  178.5 (s), 138.4 (s), 128.3 (d, 2C), 127.6 (d, 2C), 127.5 (d), 72.8 (t), 70.2 (t), 69.6 (t), 38.7 (s), 33.1 (d), 27.2 (q, 3C), 19.8 (d), 17.6 (q), 14.6 (d), 8.7 (t); MS-EI  $m/z$  (relative intensity) 304 ( $\text{M}^+$ , 1), 247 ( $\text{M}-t\text{-Bu}^+$ , 1), 197 (20), 95 (23), 92 (13), 91 (100), 57 (38). Anal. Calcd for  $\text{C}_{19}\text{H}_{28}\text{O}_3$ : C, 74.96; H, 9.27. Found: C, 74.79; H, 9.39.

### 6.3. Preparation of cyclopropanemethanols of type E

**6.3.1. (2*R*\*,3*S*\*)-2-((1*S*\*,2*S*\*)-2-((Benzyloxy)methyl)cyclopropyl)pentan-3-ol 11a and (2*R*\*,3*R*\*)-2-((1*S*\*,2*S*\*)-2-((benzyloxy)methyl)cyclopropyl)pentan-3-ol 11'a.** To a solution of **4a** (1.00 g, 4.55 mmol) in  $\text{CH}_2\text{Cl}_2$ –MeCN (9/1, 10 mL) at 0 °C, were successively added NMO (799 mg, 6.82 mmol, 1.5 equiv), 4 Å powdered molecular sieves (2.3 g) and TPAP (102 mg, 0.290 mmol, 0.06 equiv). After 3 h at rt the reaction mixture was concentrated under reduced pressure and the residue was filtered through silica gel ( $\text{CH}_2\text{Cl}_2$ – $\text{EtOAc}$ : 50/50). The filtrate was evaporated under reduced pressure and the crude aldehyde **10a** was dissolved in  $\text{Et}_2\text{O}$  (1 mL). The resulting solution was added to a solution of  $\text{EtMgBr}$  (3.0 mL, 3 M in  $\text{Et}_2\text{O}$ , 9.0 mmol, 2.0 equiv) in  $\text{Et}_2\text{O}$  (10 mL) at –50 °C. After 1 h at –50 °C, the reaction mixture was warmed to rt, poured into a saturated aqueous  $\text{NH}_4\text{Cl}$  solution and extracted with  $\text{Et}_2\text{O}$ . The combined extracts were dried over  $\text{MgSO}_4$ , filtered and concentrated under reduced pressure. The crude material was analyzed by  $^1\text{H}$  NMR and GC–MS, which indicated a 77/23 ratio of the two diastereomers **11a** and **11'a**. After purification by flash chromatography (petroleum ether– $\text{EtOAc}$  gradient: 95/5–80/20), 92 mg (8%) of **11'a** (minor diastereomer) and 358 mg (32%) of **11a** (major diastereomer) were obtained as colorless oils.

**Compound (11'a).** IR 3430, 1065, 1025, 965, 735, 700  $\text{cm}^{-1}$ ;  $^1\text{H}$  NMR  $\delta$  7.42–7.27 (m, 5H), 4.60 (d,  $J=12.5$  Hz, 1H), 4.53 (d,  $J=12.5$  Hz, 1H), 3.78 (dd,  $J=9.4, 5.1$  Hz, 1H),

3.53 (br s, 1H, OH), 3.46 (td,  $J=8.1$ , 2.9 Hz, 1H), 2.83 (dd, apparent t,  $J=9.4$  Hz, 1H), 1.71 (m, 1H), 1.42 (m, 1H), 1.17 (m, 1H), 1.01 (t,  $J=7.4$  Hz, 3H), 0.96 (d,  $J=6.6$  Hz, 3H), 0.80 (m, 1H), 0.49–0.28 (m, 3H);  $^{13}\text{C}$  NMR  $\delta$  138.2 (s), 128.3 (d, 2C), 127.5 (d, 3C), 78.5 (d), 74.2 (t), 72.7 (t), 43.4 (d), 26.7 (t), 22.1 (d), 19.4 (d), 16.7 (q), 9.8 (q), 7.2 (t); MS-EI  $m/z$  (relative intensity) 189 ( $\text{M}-\text{EtCHOH}^+$ , 0.5), 108 (19), 92 (12), 91 (100), 82 (25), 67 (18).

**Compound (11a).** IR 3420, 3060, 1090, 1060, 1025, 970, 950, 735, 700  $\text{cm}^{-1}$ ;  $^1\text{H}$  NMR  $\delta$  7.34–7.22 (m, 5H), 4.53 (d,  $J=12.1$  Hz, 1H), 4.46 (d,  $J=12.1$  Hz, 1H), 3.55 (dd,  $J=9.9$ , 5.9 Hz, 1H), 3.45 (m, 1H), 3.03 (dd,  $J=9.9$ , 8.5 Hz, 1H), 2.63 (br s, 1H, OH), 1.59–1.37 (m, 2H), 1.06–0.81 (m, 2H), 0.94 (t,  $J=7.4$  Hz, 3H), 0.93 (d,  $J=5.5$  Hz, 3H), 0.56 (m, 1H), 0.44–0.31 (m, 2H);  $^{13}\text{C}$  NMR  $\delta$  138.2 (s), 128.2 (d, 2C), 127.4 (d), 127.3 (d, 2C), 76.7 (d), 74.2 (t), 72.5 (t), 42.4 (d), 26.3 (t), 20.7 (d), 17.8 (d), 14.2 (q), 10.6 (q), 8.9 (t); MS ( $\text{CI}^+$ ,  $\text{CH}_4$ )  $m/z$  (relative intensity) 249 ( $\text{M}+\text{H}^+$ , 40), 141 (57), 123 (100), 107 (22), 91 (100), 83 (33); HRMS ( $\text{CI}^+$ ,  $\text{CH}_4$ ) Calcd for  $\text{C}_{16}\text{H}_{25}\text{O}_2$  ( $\text{M}+\text{H}^+$ ): 249.1855. Found: 249.1854.

**6.3.2. (1R\*,2R\*)-2-[(1S\*,2S\*)-2-[(Benzyloxy)methyl]cyclopropyl]-1-ethylpropyl acetate 12a.** To a solution of **11a** (224 mg, 0.902 mmol) and DMAP (57 mg, 0.47 mmol, 0.5 equiv) in  $\text{Et}_2\text{O}$  (5 mL) at rt, was added  $\text{Ac}_2\text{O}$  (200  $\mu\text{L}$ , 2.13 mmol, 2.4 equiv). After 12 h at rt, the reaction was quenched by addition of MeOH (2 mL) at 0 °C and the reaction mixture was hydrolyzed with a saturated aqueous  $\text{NaHCO}_3$  solution. The aqueous layer was extracted with  $\text{Et}_2\text{O}$  and the combined extracts were dried over  $\text{MgSO}_4$ , filtered and concentrated under reduced pressure. The residue was purified by flash chromatography (petroleum ether– $\text{EtOAc}$ : 90/10) to afford 240 mg (92%) of **12a** as a colorless oil; IR 3060, 1730, 1240, 1095, 1070, 1020, 955, 735, 700  $\text{cm}^{-1}$ ;  $^1\text{H}$  NMR  $\delta$  7.40–7.21 (m, 5H), 4.86 (ddd apparent dt,  $J=8.5$ , 4.8 Hz, 1H), 4.50 (s, 2H), 3.46 (dd,  $J=10.0$ , 6.0 Hz, 1H), 3.16 (dd,  $J=10.0$ , 7.4 Hz, 1H), 2.02 (s, 3H), 1.81–1.54 (m, 2H), 1.13–0.92 (m, 2H), 0.93 (d,  $J=6.6$  Hz, 3H), 0.86 (t,  $J=7.4$  Hz, 3H), 0.52–0.39 (m, 2H), 0.35 (m, 1H);  $^{13}\text{C}$  NMR  $\delta$  170.6 (s), 138.5 (s), 128.1 (d, 2C), 127.3 (d, 2C), 127.2 (d), 78.9 (d), 73.7 (t), 72.3 (t), 40.5 (d), 24.3 (t), 20.8 (q), 20.3 (d), 18.2 (d), 14.7 (q), 9.9 (q), 8.9 (t); MS ( $\text{CI}^+$ ,  $\text{CH}_4$ )  $m/z$  (relative intensity) 291 ( $\text{M}+\text{H}^+$ , 27), 183 (100), 123 (82), 91 (41); HRMS ( $\text{CI}^+$ ,  $\text{CH}_4$ ) Calcd for  $\text{C}_{18}\text{H}_{27}\text{O}_3$  ( $\text{M}+\text{H}^+$ ): 291.1960. Found: 291.1959.

**6.3.3. (2R\*,3R\*)-2-[(1S\*,2R\*)-2-[(Benzyloxy)methyl]cyclopropyl]pentan-3-ol 11c.** Following the procedure described for the preparation of **11a** from **6a**, compound **6c** (489 mg, 2.2 mmol) was converted to a 85/15 diastereomeric mixture of alcohols **11c** and **11'c**. Purification by flash chromatography (petroleum ether– $\text{EtOAc}$  gradient: 90/10–80/20) afforded 279 mg (51%) of **11c** as a colorless oil; IR 3420, 1090, 1070, 1025, 975, 950, 750, 735, 700  $\text{cm}^{-1}$ ;  $^1\text{H}$  NMR  $\delta$  7.38–7.27 (m, 5H), 4.56 (d,  $J=12.1$  Hz, 1H), 4.50 (d,  $J=12.1$  Hz, 1H), 3.72 (dd,  $J=10.0$ , 5.3 Hz, 1H), 3.50 (m, 1H), 3.22 (dd, apparent t,  $J=10.0$  Hz, 1H), 3.07 (br d,  $J=6.6$  Hz, 1H, OH), 1.56–1.38 (m, 2H), 1.37–1.18 (m, 2H), 1.00 (t,  $J=7.4$  Hz, 3H), 0.99 (d,  $J=7.0$  Hz, 3H), 0.86 (m, 1H), 0.73 (m, 1H), –0.11 (m, 1H);  $^{13}\text{C}$  NMR  $\delta$  137.8 (s), 128.4 (d, 2C), 127.9 (d, 2C), 127.7 (d),

76.9 (d), 72.9 (t), 70.5 (t), 38.1 (d), 26.0 (t), 18.6 (d), 16.6 (d), 16.4 (q), 11.1 (q), 7.2 (t); MS-EI  $m/z$  (relative intensity) 219 ( $\text{M}-\text{C}_2\text{H}_5^+$ , 0.3), 108 (19), 92 (13), 91 (100), 82 (26), 81 (11), 67 (19).

**6.3.4. (1R\*,2R\*)-2-[(1S\*,2R\*)-[(Benzyloxy)methyl]cyclopropyl]-1-ethylpropyl acetate 12c.** This compound was synthesized from **11c** (116 mg, 0.468 mmol) following the procedure described for the preparation of **12a** from **11a**. Purification by flash chromatography (petroleum ether– $\text{EtOAc}$ : 90/10) afforded 121 mg (89%) of **12c** as a colorless oil; IR 3050, 1735, 1240, 1090, 1075, 1025, 1015, 955, 740, 700  $\text{cm}^{-1}$ ;  $^1\text{H}$  NMR  $\delta$  7.40–7.27 (m, 5H), 4.91 (ddd, apparent td,  $J=6.9$ , 3.8 Hz, 1H), 4.57 (d,  $J=12.0$  Hz, 1H), 4.52 (d,  $J=12.0$  Hz, 1H), 3.65 (dd,  $J=10.1$ , 6.6 Hz, 1H), 3.33 (dd,  $J=10.1$ , 8.1 Hz, 1H), 2.05 (s, 3H), 1.62–1.52 (m, 2H), 1.28–1.16 (m, 2H), 1.01 (d,  $J=6.6$  Hz, 3H), 0.83 (t,  $J=7.5$  Hz, 3H), 0.85–0.74 (m, 2H), 0.05 (m, 1H);  $^{13}\text{C}$  NMR  $\delta$  170.9 (s), 138.5 (s), 128.3 (d, 2C), 127.7 (d, 2C), 127.5 (d), 78.9 (d), 72.7 (t), 70.7 (t), 35.8 (d), 24.8 (t), 21.1 (q), 20.1 (d), 16.5 (d), 15.1 (q), 10.3 (q), 8.9 (t); MS-EI  $m/z$  (relative intensity) 261 ( $\text{M}-\text{C}_2\text{H}_5^+$ , 0.1), 230 ( $\text{M}-\text{CH}_3\text{CO}_2\text{H}^+$ , 0.5), 124 (11), 95 (13), 92 (11), 91 (100), 81 (12).

**6.3.5. (3S\*,4R\*)-4-[(1S\*,2R\*)-2-[(Benzyloxy)methyl]cyclopropyl]-2-methylpent-1-en-3-ol 13.** To a solution of **4c** (970 mg, 4.41 mmol) in  $\text{CH}_2\text{Cl}_2/\text{MeCN}$  (9/1, 10 mL) at 0 °C, were successively added NMO (825 mg, 7.04 mmol, 1.5 equiv), 4 Å powdered molecular sieves (2.3 g) and TPAP (93 mg, 0.26 mmol, 0.06 equiv). After 3 h at rt the reaction mixture was concentrated under reduced pressure and the residue was filtered through silica gel ( $\text{CH}_2\text{Cl}_2$ – $\text{EtOAc}$ : 50/50). The filtrate was evaporated under reduced pressure and the crude aldehyde **10c** was dissolved in THF (2 mL). The resulting solution was added to a solution of isopropenylmagnesium bromide (18 mL, 0.5 M in THF, 9.0 mmol, 2.0 equiv) in THF (10 mL) at –30 °C. After 1 h at –30 °C, the reaction mixture was poured into a saturated aqueous  $\text{NH}_4\text{Cl}$  solution and extracted with  $\text{Et}_2\text{O}$ . The combined extracts were dried over  $\text{MgSO}_4$ , filtered and concentrated under reduced pressure. The crude material was analyzed by  $^1\text{H}$  NMR which indicated a 85/15 ratio of the two diastereomers **13** and **13'**. Purification by flash chromatography (petroleum ether– $\text{EtOAc}$ : 90/10–80/20) afforded 490 mg (43%) of **13** as a pale yellow oil; IR 3420, 3060, 1645, 1115, 1085, 1070, 1025, 900, 750, 735, 700  $\text{cm}^{-1}$ ;  $^1\text{H}$  NMR  $\delta$  7.36–7.27 (m, 5H), 4.95 (br s, 1H), 4.90 (q,  $J=1.5$  Hz, 1H), 4.57 (d,  $J=11.9$  Hz, 1H), 4.51 (d,  $J=11.9$  Hz, 1H), 4.21 (m, 1H), 3.71 (dd,  $J=9.9$ , 5.5 Hz, 1H), 3.32 (dd, apparent t,  $J=9.9$  Hz, 1H), 2.79 (d,  $J=6.3$  Hz, 1H, OH), 1.69 (br s, 3H), 1.42–1.20 (m, 2H), 0.95 (m, 1H), 0.95 (d,  $J=7.0$  Hz, 3H), 0.78 (m, 1H), –0.04 (m, 1H);  $^{13}\text{C}$  NMR  $\delta$  146.4 (s), 138.0 (s), 128.4 (d, 2C), 127.8 (d, 2C), 127.7 (d), 110.2 (t), 77.9 (d), 72.9 (t), 70.6 (t), 36.8 (d), 19.9 (q), 19.8 (d), 16.6 (d), 14.8 (q), 8.1 (t); MS ( $\text{CI}^+$ ,  $\text{CH}_4$ )  $m/z$  (relative intensity) 261 ( $\text{M}+\text{H}^+$ , 60), 243 (30), 161 (61), 153 (70), 135 (65), 107 (42), 91 (100), 71 (42); HRMS ( $\text{CI}^+$ ,  $\text{CH}_4$ ) Calcd for  $\text{C}_{17}\text{H}_{25}\text{O}_2$  ( $\text{M}+\text{H}^+$ ): 261.1855. Found: 261.1853.

**6.3.6. (2R\*,3S\*,4R\*)-4-[(1S\*,2R\*)-2-[(Benzyloxy)methyl]cyclopropyl]-2-methylpentane-1,3-diol 14.** To a solution of 9-BBN-H (5 mL, 0.5 M in THF, 2.5 mmol,

2.7 equiv) at  $-30\text{ }^{\circ}\text{C}$ , was added a solution of **13** (242 mg, 0.929 mmol) in THF (2 mL). The reaction mixture was warmed to rt and after 2 h, a 3 M aqueous NaOH solution (2.2 mL) and a 30% aqueous  $\text{H}_2\text{O}_2$  solution (2.2 mL) were successively added at  $0\text{ }^{\circ}\text{C}$ . After 2 h at rt, the resulting mixture was diluted with water and extracted with EtOAc. The combined extracts were dried over  $\text{MgSO}_4$ , filtered and concentrated under reduced pressure. The residue was purified by flash chromatography (petroleum ether–EtOAc gradient: 70/30–40/60) to afford 251 mg (97%) of **14** as a colorless oil and a 9/1 mixture of diastereomers; IR 3370, 3060, 1370, 1110, 1085, 1070, 1025, 1010, 980, 750, 740,  $700\text{ cm}^{-1}$ ; Only the major diastereomer could be accurately described;  $^1\text{H NMR}$   $\delta$  7.36–7.27 (m, 5H), 4.53 (d,  $J=11.8\text{ Hz}$ , 1H), 4.48 (d,  $J=11.8\text{ Hz}$ , 1H), 3.72–3.48 (m, 5H), 3.29 (dd, apparent t,  $J=9.4\text{ Hz}$ , 1H), 1.87–1.15 (m, 4H), 1.00 (d,  $J=7.0\text{ Hz}$ , 3H), 1.06–0.95 (m, 1H), 0.80 (m, 1H), 0.70 (d,  $J=6.8\text{ Hz}$ , 3H),  $-0.02$  (m, 1H);  $^{13}\text{C NMR}$   $\delta$  138.0 (s), 128.4 (d, 2C), 127.8 (d, 2C), 127.7 (d), 79.8 (d), 72.9 (t), 70.6 (t), 68.7 (t), 37.3 (d), 35.6 (d), 20.0 (d), 16.3 (d), 13.6 (q), 13.0 (q), 8.4 (t); MS-EI  $m/z$  (relative intensity) 219 ( $\text{M}-\text{HOCH}_2\text{CH}(\text{CH}_3)^+$ , 2), 108 (23), 107 (11), 92 (12), 91 (100), 82 (26), 81 (11), 67 (19).

**6.3.7. (2R\*,3S\*,4R\*)-3-Acetoxy-4-[(1S\*,2R\*)-2-[(benzyloxy)methyl]cyclopropyl]-2-methylpentyl acetate 15.** To a solution of **14** (240 mg, 0.863 mmol) in  $\text{Et}_2\text{O}$  (10 mL) at  $0\text{ }^{\circ}\text{C}$ , were successively added DMAP (101 mg, 0.827 mmol, 1.0 equiv) and  $\text{Ac}_2\text{O}$  (400  $\mu\text{L}$ , 4.26 mmol, 5.0 equiv). After 2 h at rt, the reaction was quenched by dropwise addition of MeOH (4 mL) at  $0\text{ }^{\circ}\text{C}$  and the resulting mixture was hydrolyzed with a saturated aqueous  $\text{NaHCO}_3$  solution. The aqueous layer was extracted with EtOAc and the combined extracts were dried over  $\text{MgSO}_4$ , filtered and concentrated under reduced pressure. The residue was purified by flash chromatography (petroleum ether–EtOAc: 80/20) to afford 255 mg (82%) of **15** as a colorless oil; IR 1740, 1235, 1070, 1020, 735,  $700\text{ cm}^{-1}$ ;  $^1\text{H NMR}$   $\delta$  7.43–7.25 (m, 5H), 5.09 (dd,  $J=9.6, 2.6\text{ Hz}$ , 1H), 4.61 (d,  $J=12.0\text{ Hz}$ , 1H), 4.55 (d,  $J=12.0\text{ Hz}$ , 1H), 3.97 (dd,  $J=11.0, 4.0\text{ Hz}$ , 1H), 3.91 (dd,  $J=11.0, 6.3\text{ Hz}$ , 1H), 3.64 (dd,  $J=10.3, 7.4\text{ Hz}$ , 1H), 3.50 (dd,  $J=10.3, 7.0\text{ Hz}$ , 1H), 2.09 (s, 3H), 2.05 (m, 1H), 2.00 (s, 3H), 1.39 (m, 1H), 1.24 (m, 1H), 1.03 (d,  $J=6.6\text{ Hz}$ , 3H), 0.89 (d,  $J=7.0\text{ Hz}$ , 3H), 0.84–0.68 (m, 2H), 0.10 (m, 1H);  $^{13}\text{C NMR}$   $\delta$  170.8 (s), 170.2 (s), 138.4 (s), 128.1 (d, 2C), 127.4 (d, 2C), 127.2 (d), 77.0 (d), 72.3 (t), 70.2 (t), 66.0 (t), 34.4 (d), 34.1 (d), 20.7 (q), 20.6 (q), 20.3 (d), 16.1 (d), 13.9 (q), 13.3 (q), 9.0 (t); MS ( $\text{CI}^+$ ,  $\text{CH}_4$ )  $m/z$  (relative intensity) 363 ( $\text{M}+\text{H}^+$ , 10), 255 (100), 195 (50), 153 (28), 135 (70), 107 (14), 91 (24); HRMS ( $\text{CI}^+$ ,  $\text{CH}_4$ ) Calcd for  $\text{C}_{21}\text{H}_{31}\text{O}_6$  ( $\text{M}+\text{H}^+$ ): 363.2171. Found: 363.2167.

## 6.4. Preparation of cyclopropanealknols of type G and H

**6.4.1. (2R\*)-2-[(1R\*,2R\*)-2-[(1R\*)-1-Hydroxypropyl]-cyclopropyl]propyl 2,2-dimethylpropanoate 17 and (2R\*)-2-[(1R\*,2R\*)-2-[(1S\*)-1-hydroxypropyl]cyclopropyl]propyl 2,2-dimethylpropanoate 17'.** To a solution of **5c** (670 mg, 3.12 mmol) in  $\text{CH}_2\text{Cl}_2$  (30 mL) at rt, were successively added powdered 4 Å molecular sieves (2.7 g) and PCC (1.35 g, 6.25 mmol, 2 equiv). After 1 h, the reaction mixture was diluted with  $\text{Et}_2\text{O}$  (200 mL) and

filtered through silica gel ( $\text{Et}_2\text{O}$ ). The filtrate was evaporated under reduced pressure to give 630 mg (94%) of the crude aldehyde **16** as a pale yellow oil, which was dissolved in THF (10 mL). To the resulting solution at  $0\text{ }^{\circ}\text{C}$ , was added  $\text{EtMgBr}$  (1.5 mL, 3 M in  $\text{Et}_2\text{O}$ , 4.5 mmol, 1.5 equiv), and after 30 min, the reaction mixture was poured into a saturated aqueous  $\text{NH}_4\text{Cl}$  solution and extracted with  $\text{Et}_2\text{O}$ . The combined extracts were dried over  $\text{MgSO}_4$ , filtered and concentrated under reduced pressure. The crude material was analyzed by  $^1\text{H NMR}$  which indicated a 60/40 ratio of the two diastereomers **17** and **17'**. Purification by flash chromatography (pentane– $\text{Et}_2\text{O}$  gradient: 80/20–50/50) afforded 130 mg (18%) of **17'** and 240 mg (34%) of **17** as colorless oils.

**Compound (17').**  $R_f$  0.32 (pentane– $\text{Et}_2\text{O}$ : 70/30); IR 3480, 3060, 1730, 1290, 1165, 1035, 990, 970,  $775\text{ cm}^{-1}$ ;  $^1\text{H NMR}$   $\delta$  4.45 (dd,  $J=11.0, 4.0\text{ Hz}$ , 1H), 3.90 (dd,  $J=11.0, 8.3\text{ Hz}$ , 1H), 3.22 (br s, 1H, OH), 3.12 (m, 1H), 1.71–1.60 (m, 2H), 1.45 (m, 1H), 1.28–1.19 (m, 1H), 1.21 (s, 9H), 1.08 (d,  $J=6.6\text{ Hz}$ , 3H), 1.00 (t,  $J=7.4\text{ Hz}$ , 3H), 0.73 (m, 1H), 0.58 (m, 1H),  $-0.06$  (m, 1H);  $^{13}\text{C NMR}$   $\delta$  179.1 (s), 73.6 (d), 70.0 (t), 38.8 (s), 32.6 (d), 30.7 (t), 27.1 (q, 3C), 23.4 (d), 19.2 (d), 18.1 (q), 10.2 (q), 7.9 (t); MS-EI  $m/z$  (relative intensity) 225 ( $\text{M}-\text{OH}^+$ , 1), 213 ( $\text{M}-\text{C}_2\text{H}_5^+$ , 5), 140 ( $\text{M}-t\text{-BuCO}_2\text{H}^+$ , 8), 111 (43), 103 (11), 93 (28), 85 (30), 82 (14), 81 (18), 69 (29), 67 (15), 57 (100), 55 (18).

**Compound (17).**  $R_f$  0.18 (pentane– $\text{Et}_2\text{O}$ : 70/30); IR 3450, 3070, 1730, 1290, 1165, 1035, 990, 965, 855,  $775\text{ cm}^{-1}$ ;  $^1\text{H NMR}$   $\delta$  4.18 (dd,  $J=10.7, 3.7\text{ Hz}$ , 1H), 3.79 (dd,  $J=10.7, 8.5\text{ Hz}$ , 1H), 3.35 (ddd apparent td,  $J=7.8, 3.7\text{ Hz}$ , 1H), 2.00 (br s, 1H, OH), 1.73 (m, 1H), 1.67–1.46 (m, 2H), 1.21 (s, 9H), 1.01–0.93 (m, 1H), 1.07 (d,  $J=6.6\text{ Hz}$ , 3H), 1.03 (t,  $J=7.4\text{ Hz}$ , 3H), 0.76–0.67 (m, 2H), 0.21 (m, 1H);  $^{13}\text{C NMR}$   $\delta$  178.6 (s), 72.3 (d), 69.0 (t), 38.8 (s), 32.8 (d), 31.3 (t), 27.2 (q, 3C), 23.4 (d), 20.4 (d), 18.0 (q), 10.0 (q), 7.1 (t); MS-EI  $m/z$  (relative intensity) 225 ( $\text{M}-\text{OH}^+$ , 1), 213 ( $\text{M}-\text{C}_2\text{H}_5^+$ , 5), 140 ( $\text{M}-t\text{-BuCO}_2\text{H}^+$ , 7), (111 (41), 103 (12), 93 (28), 85 (29), 81 (18), 69 (29), 67 (15), 57 (100), 55 (18).

## 6.4.2. Epimerization of 17 to 17' by an oxidation-stereoselective reduction sequence.

To a solution of **17** (50 mg, 0.21 mmol) in  $\text{CH}_2\text{Cl}_2$  (5 mL) at rt, were added powdered 4 Å molecular sieves (200 mg) and PCC (90 mg, 0.42 mmol, 2 equiv). After 2 h, the reaction mixture was diluted with  $\text{Et}_2\text{O}$  (50 mL) and filtered through silica gel ( $\text{Et}_2\text{O}$ ). The filtrate was evaporated and the crude cyclopropylketone **18** was dissolved in MeOH (4 mL). To the resulting solution at  $0\text{ }^{\circ}\text{C}$ , was added portionwise  $\text{NaBH}_4$  (40 mg, 1.0 mmol, 5 equiv). After 1 h at rt, the reaction mixture was hydrolyzed with a saturated aqueous  $\text{NH}_4\text{Cl}$  solution and extracted with  $\text{Et}_2\text{O}$ . The combined extracts were dried over  $\text{MgSO}_4$ , filtered and concentrated under reduced pressure. The crude material was analyzed by  $^1\text{H NMR}$  and GC–MS which indicated a 12/88 ratio of the two diastereomers **17** and **17'**. Purification by flash chromatography (petroleum ether–EtOAc: 90/10, 80/20) afforded 36 mg (72%) of **17'** as a colorless oil.

**6.4.3. ((2R\*)-2-[(1S\*,2R\*)-2-[(Benzyloxy)methyl]cyclopropyl]propoxy-*tert*-butyldiphenylsilane 19.** To a solution of **4c** (1.87 g, 8.50 mmol) and imidazole (1.41 g,

20.7 mmol, 2.4 equiv) in DMF (8 mL) was added TBDPSCl (2.70 mL, 10.4 mmol, 1.2 equiv). After 1 h at rt, the reaction mixture was hydrolyzed with a saturated aqueous  $\text{NH}_4\text{Cl}$  solution and extracted with a petroleum ether– $\text{CH}_2\text{Cl}_2$  (90/10) mixture. The combined extracts were washed with brine, dried over  $\text{MgSO}_4$ , filtered and concentrated under reduced pressure. The residue was purified by flash chromatography (petroleum ether–EtOAc: 95/5) to afford 3.47 g (89%) of **19** as a colorless oil; IR 3060, 1590, 1110, 1080, 820, 740, 710, 700, 690, 610  $\text{cm}^{-1}$ ;  $^1\text{H}$  NMR  $\delta$  7.75–7.69 (m, 4H), 7.48–7.35 (m, 6H), 7.34–7.25 (m, 5H), 4.43 (d,  $J=12.1$  Hz, 1H), 4.38 (d,  $J=12.1$  Hz, 1H), 3.79 (dd,  $J=9.7, 4.2$  Hz, 1H), 3.57 (dd,  $J=9.7, 7.2$  Hz, 1H), 3.43 (dd,  $J=10.3, 7.0$  Hz, 1H), 3.31 (dd,  $J=10.3, 7.5$  Hz, 1H), 1.28 (m, 1H), 1.17 (d,  $J=6.3$  Hz, 3H), 1.11 (m, 1H), 1.10 (s, 9H), 0.82–0.69 (m, 2H), 0.05 (m, 1H);  $^{13}\text{C}$  NMR  $\delta$  138.6 (s), 135.6 (d, 4C), 134.2 (s), 134.0 (s), 129.5 (d, 2C), 128.3 (d, 2C), 127.6 (d, 2C), 127.5 (d, 4C), 127.3 (d), 72.6 (t), 70.7 (t), 68.8 (t), 36.1 (d), 26.9 (q, 3C), 19.7 (d), 19.3 (s), 17.8 (q), 16.1 (d), 8.6 (t); MS-EI  $m/z$  (relative intensity) 401 ( $\text{M}-t\text{-Bu}^+$ , 2), 319 (20), 290 (14), 289 (52), 259 (31), 233 (40), 211 (28), 205 (29), 199 (32), 183 (35), 167 (23), 139 (23), 135 (20), 95 (27), 91 (100); HRMS ( $\text{CI}^+$ ,  $\text{CH}_4$ ) Calcd for  $\text{C}_{30}\text{H}_{39}\text{O}_2\text{Si}$  ( $\text{M}+\text{H}^+$ ): 459.2719. Found: 459.2721.

**6.4.4.  $\{(1R^*,2S^*)\text{-2-}[(1R^*)\text{-2-}(tert\text{-Butyldiphenylsilyl)oxy-1-methylethyl]cyclopropyl\}$ methanol **20**.** To a solution of **19** (1.80 g, 3.91 mmol) in EtOH (60 mL) was added Pd/C (250 mg, 5% Pd, 0.117 mmol, 0.03 equiv) and the resulting mixture was stirred under an atmosphere of  $\text{H}_2$ . After 24 h, the reaction mixture was diluted with  $\text{CH}_2\text{Cl}_2$  and filtered through Celite. The filtrate was concentrated under reduced pressure and the residue was purified by flash chromatography (petroleum ether–EtOAc: 85/15) to afford 2.21 g (86%) of **20** as a white solid; mp = 74 °C; IR 3580, 3410, 3060, 3020, 1590, 1110, 1040, 825, 740, 705, 690  $\text{cm}^{-1}$ ;  $^1\text{H}$  NMR  $\delta$  7.74–7.70 (m, 4H), 7.49–7.38 (m, 6H), 3.83 (m, 1H), 3.60 (dd,  $J=10.0, 5.1$  Hz, 1H), 3.43 (dd,  $J=10.0, 8.3$  Hz, 1H), 3.31–3.21 (m, 2H), 1.46 (m, 1H), 1.30 (m, 1H), 1.09 (s, 9H), 0.93 (d,  $J=7.0$  Hz, 3H), 0.72–0.59 (m, 2H), –0.06 (m, 1H);  $^{13}\text{C}$  NMR  $\delta$  135.7 (d, 2C), 135.6 (d, 2C), 133.1 (s), 133.0 (s), 129.7 (d, 2C), 127.7 (d, 4C), 70.7 (t), 63.1 (t), 34.5 (d), 26.8 (q, 3C), 20.8 (d), 19.4 (d), 19.1 (s), 17.8 (q), 7.0 (t); MS-EI  $m/z$  (relative intensity) 311 ( $\text{M}-t\text{-Bu}^+$ , 1), 229 (21), 200 (20), 199 (100), 181 (10), 139 (8), 95 (28); HRMS ( $\text{CI}^+$ ,  $\text{CH}_4$ ) Calcd for  $\text{C}_{23}\text{H}_{33}\text{O}_2\text{Si}$  ( $\text{M}+\text{H}^+$ ): 369.2250. Found: 369.2248.

**6.4.5.  $3\text{-}[(1R^*,2S^*)\text{-2-}[(1R^*)\text{-2-}(tert\text{-Butyldiphenylsilyl)oxy-1-methylethyl]cyclopropyl]\text{-2-methylprop-2-en-1-ol}$  **21**.** To a solution of **20** (2.03 g, 5.51 mmol) in  $\text{CH}_2\text{Cl}_2$  (100 mL) at rt, were successively added powdered 4 Å molecular sieves (4.8 g) and PCC (2.55 g, 11.8 mmol, 2.1 equiv). After 4 h, the reaction mixture was diluted with  $\text{Et}_2\text{O}$  and filtered through silica gel ( $\text{Et}_2\text{O}$ ). The filtrate was evaporated under reduced pressure, and the crude aldehyde was dissolved in toluene (50 mL). To the resulting solution was added (carboethoxyethylidene)triphenylphosphorane (3.12 g, 8.59 mmol, 1.5 equiv) and the reaction mixture was heated at reflux. After 12 h, an additional quantity of (carboethoxyethylidene)triphenylphosphorane (2.14 g, 5.90 mmol, 1.1 equiv) was added and the reaction mixture was heated at reflux. After 2 h, the

reaction mixture was cooled to rt, evaporated under reduced pressure and the residue was triturated in pentane. The insoluble triphenylphosphine oxide was removed by filtration through Celite (pentane) and the filtrate was evaporated under reduced pressure. The crude resulting  $\alpha,\beta$ -unsaturated ester (2.38 g, 5.28 mmol) was dissolved in  $\text{CH}_2\text{Cl}_2$  (70 mL), and to the resulting solution at –70 °C, was added DIBAL-H (15.0 mL, 1 M in hexanes, 15.0 mmol, 2.8 equiv). After 3 h, the reaction mixture was poured into a saturated aqueous solution of Rochelle salt (200 mL). After 3 h stirring, the resulting mixture was extracted with  $\text{Et}_2\text{O}$  and the combined extracts were dried over  $\text{MgSO}_4$ , filtered and concentrated under reduced pressure. The residue was purified by flash chromatography (petroleum ether–EtOAc: 83/17) to afford 1.35 g (60% from **20**, 3 steps) of **21** as a colorless oil;  $R_f$  0.30 (petroleum ether–EtOAc: 80/20); IR 3340, 3060, 1110, 1075, 820, 765, 740, 710, 700, 690  $\text{cm}^{-1}$ ;  $^1\text{H}$  NMR  $\delta$  7.69–7.64 (m, 4H), 7.48–7.33 (m, 6H), 4.99 (dq,  $J=9.4, 1.5$  Hz, 1H), 3.83 (d,  $J=5.9$  Hz, 2H), 3.62 (dd,  $J=9.6, 4.1$  Hz, 1H), 3.42 (dd,  $J=9.6, 7.7$  Hz, 1H), 1.64 (d,  $J=1.5$  Hz, 3H), 1.48 (m, 1H), 1.29 (m, 1H), 1.18 (d,  $J=6.3$  Hz, 3H), 1.04 (s, 9H), 0.98–0.87 (m, 2H), 0.81 (m, 1H), 0.17 (m, 1H);  $^{13}\text{C}$  NMR  $\delta$  135.6 (d, 2C), 135.5 (d, 2C), 135.4 (s), 134.2 (s), 134.0 (s), 129.5 (d, 2C), 127.5 (d, 4C), 126.2 (d), 69.0 (t), 68.2 (t), 36.6 (d), 26.8 (q, 3C), 21.9 (d), 19.3 (s), 17.6 (q), 14.9 (d), 13.9 (q), 12.6 (t); MS-EI  $m/z$  (relative intensity) 351 ( $\text{M}-t\text{-Bu}^+$ , 1), 229 (10), 200 (19), 199 (100), 197 (14), 181 (12), 135 (40), 107 (12), 93 (17); HRMS ( $\text{CI}^+$ ,  $\text{NH}_3$ ) Calcd for  $\text{C}_{26}\text{H}_{40}\text{NO}_2\text{Si}$  ( $\text{M}+\text{NH}_4^+$ ): 426.2828. Found: 426.2814.

**6.4.6. Hydroboration of **21**.** To a solution of *T*-hexylborane [prepared from  $\text{BH}_3\cdot\text{THF}$  (2.2 mL, 1 M in THF, 2.2 mmol, 2.6 equiv) and 2,3-dimethylbut-2-ene (2.2 mL, 1 M in THF, 2.2 mmol, 2.6 equiv), 2 h stirring at 0 °C] at –40 °C, was added a solution of **21** (350 mg, 0.856 mmol) in THF (3 mL). The reaction mixture was gradually warmed to rt over 3 h. After 18 h, the reaction mixture was cooled to 0 °C and a 3 M aqueous NaOH solution (2 mL) and a 30% aqueous  $\text{H}_2\text{O}_2$  solution (2 mL) were successively added. After 3 h at rt, the resulting mixture was extracted with  $\text{Et}_2\text{O}$  and the combined extracts were washed with brine, dried over  $\text{MgSO}_4$ , filtered and concentrated under reduced pressure. The residue was purified by flash chromatography (petroleum ether–EtOAc gradient: 75/25–40/60) to afford 21 mg (6%) of **22'**, 258 mg (71%) of **22** and 20 mg (6%) of **22''** as colorless oils.

**6.4.7.  $(1R^*,2S^*)\text{-1-}[(1R^*,2R^*)\text{-2-}[(1R^*)\text{-2-}(tert\text{-Butyldiphenylsilyl)oxy-1-methylethyl]cyclopropyl]\text{-2-methylpropan-1,3-diol}$  **22'**.**  $R_f$  0.54 (petroleum ether–EtOAc: 50/50); IR 3380, 3060, 1115, 1035, 820, 805, 740, 705  $\text{cm}^{-1}$ ;  $^1\text{H}$  NMR  $\delta$  7.73–7.68 (m, 4H), 7.49–7.37 (m, 6H), 5.18 (br s, 1H, OH), 3.95 (br s, 1H, OH), 3.68–3.61 (m, 2H), 3.66 (dd,  $J=9.9, 4.0$  Hz, 1H), 3.33 (dd, apparent t,  $J=9.9$  Hz, 1H), 3.09 (dd,  $J=9.9, 7.9$  Hz, 1H), 1.97 (m, 1H), 1.58 (m, 1H), 1.22 (m, 1H), 1.08 (s, 9H), 0.95 (d,  $J=7.0$  Hz, 3H), 0.83 (d,  $J=7.0$  Hz, 3H), 0.79 (m, 1H), 0.58 (m, 1H), 0.04 (m, 1H);  $^{13}\text{C}$  NMR  $\delta$  135.7 (d, 2C), 135.6 (d, 2C), 132.5 (s), 132.4 (s), 129.9 (d, 2C), 127.8 (d, 2C), 127.7 (d, 2C), 79.1 (d), 71.3 (t), 68.9 (t), 41.4 (d), 34.2 (d), 26.8 (q, 3C), 23.8 (d), 20.3 (d), 19.0 (s), 17.8 (q), 14.0 (q), 8.4 (t); MS ( $\text{CI}^+$ ,  $\text{CH}_4$ )  $m/z$  (relative intensity) 427 ( $\text{M}+\text{H}^+$ , 94), 409 (39), 391 (30),

331 (100), 269 (25), 133 (30); HRMS ( $\text{CI}^+$ ,  $\text{CH}_4$ ) Calcd for  $\text{C}_{26}\text{H}_{39}\text{O}_3\text{Si}$  ( $\text{M} + \text{H}^+$ ): 427.2668. Found: 427.2667.

**6.4.8. (1S\*,2R\*)-1-[(1R\*,2R\*)-2-[(1R\*)-2-(tert-Butyldiphenylsilyloxy-1-methylethyl)cyclopropyl]-2-methylpropan-1,3-diol 22.**  $R_f$  0.37 (petroleum ether–EtOAc: 50/50); IR 3350, 3070, 1590, 1110, 1075, 1030, 970, 825, 770, 740, 705,  $690\text{ cm}^{-1}$ ;  $^1\text{H NMR}$   $\delta$  7.72–7.67 (m, 4H), 7.50–7.37 (m, 6H), 3.78 (dd,  $J=10.8$ , 3.1 Hz, 1H), 3.63 (dd,  $J=9.9$ , 5.5 Hz, 1H), 3.51 (dd,  $J=9.9$ , 6.4 Hz, 1H), 3.50 (dd,  $J=11.9$ , 6.4 Hz, 1H), 3.38 (dd, apparent t,  $J=6.4$  Hz, 1H), 3.20 (br s, 1H, OH), 2.84 (br s, 1H, OH), 1.68 (m, 1H), 1.54 (m, 1H), 1.10–1.00 (m, 1H), 1.12 (d,  $J=6.6$  Hz, 3H), 1.09 (s, 9H), 0.86 (d,  $J=7.0$  Hz, 3H), 0.83–0.67 (m, 2H), 0.22 (m, 1H);  $^{13}\text{C NMR}$   $\delta$  135.6 (d, 2C), 135.5 (d, 2C), 133.6 (s), 133.5 (s), 129.6 (d, 2C), 127.6 (d, 4C), 75.9 (d), 69.0 (t), 66.7 (t), 40.8 (d), 35.3 (d), 26.8 (q, 3C), 22.7 (d), 21.5 (d), 19.2 (s), 18.2 (q), 14.3 (q), 6.2 (t); MS ( $\text{CI}^+$ ,  $\text{CH}_4$ )  $m/z$  (relative intensity) 427 ( $\text{M} + \text{H}^+$ , 62), 409 (100), 391 (17), 331 (48), 160 (14), 139 (14); HRMS ( $\text{CI}^+$ ,  $\text{CH}_4$ ) Calcd for  $\text{C}_{26}\text{H}_{39}\text{O}_3\text{Si}$  ( $\text{M} + \text{H}^+$ ): 427.2668. Found: 427.2667.

**6.4.9. (E)-(2S\*,5R\*)-2-[(1R\*)-2-(tert-Butyldiphenylsilyloxy-1-methylethyl)-5-methylhex-3-en-1,6-diol 22'.**  $R_f$  0.24 (petroleum ether–EtOAc: 50/50); IR 3350, 3060, 1110, 1085, 1030, 820, 740,  $705\text{ cm}^{-1}$ ;  $^1\text{H NMR}$   $\delta$  7.70–7.65 (m, 4H), 7.48–7.37 (m, 6H), 5.42 (dd,  $J=15.4$ , 6.8 Hz, 1H), 5.33 (dd,  $J=15.4$ , 7.9 Hz, 1H), 3.71 (dd,  $J=10.7$ , 5.2 Hz, 1H), 3.61 (dd,  $J=10.3$ , 5.9 Hz, 1H), 3.53–3.46 (m, 2H), 3.44 (dd,  $J=10.3$ , 5.5 Hz, 1H), 3.35 (dd,  $J=10.7$ , 7.2 Hz, 1H), 2.36–2.23 (m, 2H), 1.79 (m, 1H), 1.71–1.49 (2H, OH), 1.07 (s, 9H), 0.98 (d,  $J=6.6$  Hz, 3H), 0.93 (d,  $J=6.6$  Hz, 3H);  $^{13}\text{C NMR}$   $\delta$  136.2 (d), 135.6 (d, 2C), 135.5 (d, 2C), 133.5 (s, 2C), 130.4 (d), 129.7 (d, 2C), 127.7 (d, 4C), 67.2 (t), 66.9 (t), 64.0 (t), 48.6 (d), 39.5 (d), 37.1 (d), 26.9 (q, 3C), 19.2 (s), 16.4 (q), 15.1 (q); MS ( $\text{CI}^+$ ,  $\text{CH}_4$ )  $m/z$  (relative intensity) 427 ( $\text{M} + \text{H}^+$ , 100), 409 (40), 369 (12), 349 (28), 331 (23); HRMS ( $\text{CI}^+$ ,  $\text{CH}_4$ ) Calcd for  $\text{C}_{26}\text{H}_{39}\text{O}_3\text{Si}$  ( $\text{M} + \text{H}^+$ ): 427.2669. Found 427.2670.

**6.4.10. (1R\*,2S\*)-1-[(1R\*,2R\*)-2-[(1R\*)-2-Hydroxy-1-methylethyl)cyclopropyl]-2-methylpropan-1,3-diol 23.** To a solution of **22** (560 mg, 1.31 mmol) in THF (10 mL) at  $0^\circ\text{C}$ , was added dropwise a solution of  $n\text{-Bu}_4\text{NF}$  (4.0 mL, 1 M in THF, 4.0 mmol, 3.1 equiv). After 3 h at rt, the reaction mixture was concentrated under reduced pressure and the residue was purified by flash chromatography (Petroleum ether–EtOAc: 50/50 then EtOAc–MeOH: 90/10) to afford 188 mg (76%) of **23** as a colorless oil; IR 3300, 1450,  $1025$ ,  $965\text{ cm}^{-1}$ ;  $^1\text{H NMR}$   $\delta$  3.83 (dd,  $J=10.9$ , 3.5 Hz, 1H), 3.70–3.20 (3H, OH), 3.63 (dd,  $J=10.9$ , 6.8 Hz, 1H), 3.62 (dd, apparent t,  $J=6.2$  Hz, 1H), 3.55 (dd,  $J=10.7$ , 6.6 Hz, 1H), 3.48 (dd,  $J=10.7$ , 6.1 Hz, 1H), 1.85 (m, 1H), 1.52 (m, 1H), 1.04 (m, 1H), 1.02 (d,  $J=6.3$  Hz, 3H), 0.99 (d,  $J=7.0$  Hz, 3H), 0.72–0.59 (m, 2H), 0.22 (m, 1H);  $^{13}\text{C NMR}$   $\delta$  75.0 (d), 68.2 (t), 66.7 (t), 40.8 (d), 35.1 (d), 21.9 (d), 21.8 (d), 18.1 (q), 14.1 (q), 5.8 (t).

**6.4.11. (2S\*,3R\*)-3-[(1R\*,2R\*)-2-[(1R\*)-2-(2,2-Dimethylpropanoyloxy)-1-methylethyl)cyclopropyl]-3-hydroxy-2-methylpropyl 2,2-dimethylpropanoate 24.** To a solution of **23** (60 mg, 0.32 mmol) and DMAP (87 mg, 0.71 mmol, 2.2 equiv) in  $\text{CH}_2\text{Cl}_2$  (5 mL) at  $0^\circ\text{C}$ , was added PivCl

(84  $\mu\text{L}$ , 0.68 mmol, 2.1 equiv). After 2.5 h at  $0^\circ\text{C}$ , the reaction mixture was hydrolyzed with a saturated aqueous  $\text{NaHCO}_3$  solution and extracted with  $\text{CH}_2\text{Cl}_2$ . The combined extracts were dried over  $\text{MgSO}_4$ , filtered and concentrated under reduced pressure. The residue was purified by flash chromatography (petroleum ether–EtOAc gradient: 90/10–80/20) to afford 72 mg (63%) of **24** as a colorless oil; IR 3500, 1730, 1285, 1160, 1030, 985,  $770\text{ cm}^{-1}$ ;  $^1\text{H NMR}$   $\delta$  4.26 (dd,  $J=10.9$ , 5.2 Hz, 1H), 4.26–4.16 (m, 1H), 4.19 (dd,  $J=10.9$ , 6.4 Hz, 1H), 3.76 (dd,  $J=10.7$ , 8.5 Hz, 1H), 3.52 (dd, apparent t,  $J=5.5$  Hz, 1H), 2.22 (br s, 1H, OH), 2.00 (m, 1H), 1.61 (m, 1H), 1.21 (s, 9H), 1.20 (s, 9H), 1.10 (d,  $J=7.0$  Hz, 3H), 1.07 (d,  $J=7.0$  Hz, 3H), 1.12–0.90 (m, 1H), 0.77–0.64 (m, 2H), 0.33 (m, 1H);  $^{13}\text{C NMR}$   $\delta$  178.7 (s, 2C), 71.4 (d), 69.0 (t), 66.0 (t), 40.1 (d), 38.8 (s, 2C), 32.3 (d), 27.2 (q, 6C), 21.3 (d), 20.3 (d), 18.1 (q), 14.5 (q), 6.3 (t); MS ( $\text{CI}^+$ ,  $\text{CH}_4$ )  $m/z$  (relative intensity) 357 ( $\text{M} + \text{H}^+$ , 5), 340 (33), 339 ( $\text{M} + \text{H}^+ - \text{H}_2\text{O}$ , 100), 255 (11), 237 (14), 153 (10), 135 (16); HRMS ( $\text{CI}^+$ ,  $\text{CH}_4$ ) Calcd for  $\text{C}_{20}\text{H}_{37}\text{O}_5$  ( $\text{M} + \text{H}^+$ ): 357.2641. Found: 357.2646.

## 6.5. Oxymercuration–reductive demercuration of cyclopropanemethanols of type D

### 6.5.1. Oxymercuration of 5a: representative procedure.

To a degassed solution of **5a** (400 mg, 1.87 mmol) in  $\text{CH}_2\text{Cl}_2$  (15 mL) [argon bubbling, 15 min] at rt, was added  $\text{Hg}(\text{OCOFCF}_3)_2$  (1.59 g, 3.74 mmol, 2 equiv). After 1 h with exclusion of light [reaction flask wrapped with an aluminum foil], the reaction mixture was hydrolyzed with a saturated aqueous KBr solution and extracted with  $\text{CH}_2\text{Cl}_2$ . The combined extracts were dried over  $\text{MgSO}_4$ , filtered and concentrated under reduced pressure. The crude material was purified by flash chromatography (cyclohexane–EtOAc gradient: 40/60–60/40) to afford 191 mg (20%) of a mixture of **25'a** and **25''a** (80/20 ratio) and 562 mg (60%) of **25a**, as colorless foams.

**6.5.1.1. Organomercuric 25a.** IR 3440, 1710, 1280, 1170,  $1025\text{ cm}^{-1}$ ;  $^1\text{H NMR}$   $\delta$  4.71 (dd,  $J=6.9$ , 5.7 Hz, 1H), 3.61 (dd,  $J=11.2$ , 4.6 Hz, 2H), 3.45 (dd,  $J=11.2$ , 5.5 Hz, 1H), 3.38 (dd,  $J=11.2$ , 6.2 Hz, 1H), 2.40 (m, 1H), 1.98 (m, 1H), 1.83 (dd,  $J=11.9$ , 4.4 Hz, 1H), 1.73 (dd,  $J=11.9$ , 7.8 Hz, 1H), 1.17 (s, 9H), 0.95 (d,  $J=6.9$  Hz, 3H);  $^{13}\text{C NMR}$   $\delta$  179.6 (s), 77.8 (d), 63.2 (t), 62.4 (t), 41.3 (d), 39.1 (s), 36.5 (d), 32.5 (t), 27.2 (q, 3C), 14.6 (q).

**6.5.1.2. Organomercuric 25'a.** IR 3440, 1710, 1290, 1165,  $1030\text{ cm}^{-1}$ ;  $^1\text{H NMR}$   $\delta$  4.29 (dd,  $J=11.1$ , 5.3 Hz, 1H), 4.15 (dd,  $J=11.1$ , 4.0 Hz, 1H), 3.96 (dd,  $J=11.0$ , 4.4 Hz, 1H), 3.67 (dd,  $J=11.0$ , 3.4 Hz, 1H), 3.31 (dd,  $J=8.4$ , 3.7 Hz, 1H), 2.38 (m, 1H), 2.01 (m, 1H), 2.01 (dd,  $J=11.9$ , 4.5 Hz, 1H), 1.88 (dd,  $J=11.9$ , 5.7 Hz, 1H), 1.22 (s, 9H), 1.00 (d,  $J=6.8$  Hz, 3H);  $^{13}\text{C NMR}$   $\delta$  179.6 (s), 77.3 (d), 66.5 (t), 63.6 (t), 40.1 (d), 38.9 (s), 36.8 (d), 33.7 (t), 27.2 (q, 3C), 14.3 (q).

**6.5.1.3. Organomercuric 25''a.** These spectroscopic data have been tentatively deduced from the spectra of a mixture of **25'a** and **25''a** (80/20 ratio);  $^1\text{H NMR}$   $\delta$  4.28 (m, 1H), 3.96 (m, 1H), 3.86 (dd,  $J=10.6$ , 3.7 Hz, 1H), 3.62 (m, 1H), 3.50 (m, 1H), 2.65 (m, 1H), 2.15–1.85 (m, 3H), 1.23 (s, 9H), 0.91 (d,  $J=6.9$  Hz, 3H);  $^{13}\text{C NMR}$   $\delta$  178.9 (s), 79.1 (d),

68.4 (t), 65.8 (t), 39.5 (d), 38.8 (s), 37.3 (d), 34.3 (t), 27.0 (q, 3C), 13.4 (q).

**6.5.2. Reductive demercuration of 25a: representative procedure.** To a degassed solution of **25a** (560 mg, 1.10 mmol) in THF (12 mL) [argon bubbling, 15 min] at rt, were added a catalytic amount of AIBN (2 mg) and *n*-Bu<sub>3</sub>SnH (590 μL, 2.19 mmol). Mercury began to precipitate almost instantaneously, and after 1 h at rt the reaction mixture was hydrolyzed with a 20% aqueous KF solution (3 mL). After 30 min, the reaction mixture was diluted with EtOAc, filtered through Celite, and the filtrate was extracted with EtOAc. The combined extracts were dried over MgSO<sub>4</sub>, filtered and concentrated under reduced pressure. The crude material was purified by flash chromatography (cyclohexane–EtOAc: 60/40–40/60) to afford 244 mg (96%) of **26a** as a colorless oil.

**6.5.2.1. (1S\*,2R\*)-3-Hydroxy-1-((1S\*)-2-hydroxy-1-methylethyl)-2-methylpropyl 2,2-dimethylpropanoate 26a.** IR 3380, 1710, 1285, 1170, 1030 cm<sup>-1</sup>; <sup>1</sup>H NMR δ 4.80 (t, *J*=6.4 Hz, 1H), 3.62 (dd, *J*=11.2, 3.8 Hz, 2H), 3.44 (dd, *J*=11.2, 5.8 Hz, 2H), 3.03 (br s, 2H, OH), 2.00 (m, 2H), 1.23 (s, 9H), 1.02 (d, *J*=6.9 Hz, 6H); <sup>13</sup>C NMR δ 179.4 (s), 77.4 (d), 63.2 (t, 2C), 39.0 (s), 36.5 (d, 2C), 27.1 (q, 3C), 14.4 (q, 2C); MS-EI *m/z* (relative intensity) 173 (M–CH<sub>3</sub>CHCH<sub>2</sub>OH<sup>+</sup>, 4), 147 (5), 133 (M–*t*-BuCO<sup>+</sup>, 9), 103 (61), 95 (16), 89 (20), 85 (37), 82 (12), 71 (14), 69 (18), 57 (100), 55 (11).

**6.5.2.2. (2S\*,3R\*,4R\*)-3,5-Dihydroxy-2,4-dimethylpentyl 2,2-dimethylpropanoate 26'a.** Reductive demercuration of a mixture of **25'a** and **25''a** (80/20 ratio, 150 mg, 0.294 mmol) with *n*-Bu<sub>3</sub>SnH (150 μL, 0.557 mmol) in the presence of a catalytic amount of AIBN in THF (4 mL) at rt, and purification by flash chromatography (cyclohexane–EtOAc: 60/40–40/60) afforded 66 mg (98%) of **26'a** as a colorless oil; IR 3400, 1710, 1285, 1165, 1030 cm<sup>-1</sup>; <sup>1</sup>H NMR δ 4.22 (dd, *J*=11.0, 4.8 Hz, 1H), 4.13 (dd, *J*=11.0, 6.2 Hz, 1H), 3.84 (dd, *J*=10.8, 3.4 Hz, 1H), 3.61 (dd, *J*=10.8, 6.3 Hz, 1H), 3.50 (br m, 1H, OH), 3.41 (dd apparent t, *J*=6.1 Hz, 1H), 3.10 (br m, 1H, OH), 2.07 (m, 1H), 1.88 (m, 1H), 1.21 (s, 9H), 1.02 (d, *J*=7.0 Hz, 3H), 1.00 (d, *J*=7.0 Hz, 3H); <sup>13</sup>C NMR δ 179.0 (s), 79.4 (d), 66.8 (t), 66.0 (t), 38.9 (s), 36.5 (d), 36.0 (d), 27.2 (q, 3C), 14.7 (q), 14.5 (q); MS-EI *m/z* (relative intensity) 173 (M–CH<sub>3</sub>CHCH<sub>2</sub>OH<sup>+</sup>, 16), 103 (100), 89 (42), 85 (57), 82 (10), 71 (22), 57 (84).

**6.5.3. Oxymercuration–reductive demercuration of 5b.** Compound **5b** (530 mg, 2.47 mmol) was subjected to the oxymercuration–reductive demercuration representative procedures. Purification by flash chromatography (cyclohexane–EtOAc: 70/30–50/50) afforded 451 mg (80%) of a regioisomeric mixture of **26b** and **26'b** (95/5 ratio).

**6.5.3.1. (2R\*)-3-Hydroxy-1-((1R\*)-2-hydroxy-1-methyl-ethyl)-2-methylpropyl 2,2-dimethylpropanoate 26b.** IR 3400, 1710, 1285, 1180, 1030 cm<sup>-1</sup>; <sup>1</sup>H NMR δ 4.99 (dd, *J*=9.9, 2.2 Hz, 1H), 3.54 (dd, *J*=11.2, 3.5 Hz, 1H), 3.45 (dd, *J*=11.2, 5.5 Hz, 1H), 3.44 (dd, *J*=11.1, 4.8 Hz, 1H), 3.22 (dd, *J*=11.1, 9.4 Hz, 1H), 3.09 (br s, 1H, OH), 2.65 (br s, 1H, OH), 2.10–1.89 (m, 2H), 1.24 (s, 9H),

1.00 (d, *J*=7.0 Hz, 3H), 0.85 (d, *J*=7.0 Hz, 3H); <sup>13</sup>C NMR δ 179.9 (s), 73.4 (d), 64.4 (t), 64.0 (t), 39.2 (s), 36.7 (d), 36.5 (d), 27.2 (q, 3C), 13.6 (q), 9.5 (q).

**6.5.3.2. (2R\*,3S\*,4R\*)-3,5-Dihydroxy-2,4-dimethylpentyl 2,2-dimethylpropanoate 26'b.** IR 3400, 1730, 1710, 1290, 1170, 1030 cm<sup>-1</sup>; <sup>1</sup>H NMR δ 4.25 (dd, *J*=11.0, 8.5 Hz, 1H), 3.91 (dd, *J*=11.0, 5.5 Hz, 1H), 3.78–3.60 (m, 2H), 3.47 (d, *J*=9.2, 2.2 Hz, 1H), 2.03–1.73 (m, 2H), 1.22 (s, 9H), 0.91 (d, *J*=7.0 Hz, 3H), 0.79 (d, *J*=7.0 Hz, 3H); <sup>13</sup>C NMR δ 179.3 (s), 76.4 (d), 68.6 (t), 66.7 (t), 38.8 (s), 36.9 (d), 35.2 (d), 27.2 (q, 3C), 13.4 (q), 8.9 (q).

**6.5.4. Oxymercuration–reductive demercuration of cyclopropylcarbinol 5c.** According to the representative procedure, oxymercuration of **5c** (400 mg, 1.87 mmol) and subsequent purification by flash chromatography (cyclohexane–EtOAc: 80/20) afforded 165 mg (17%) of an inseparable mixture of **25'c** and **25''c** (75/25 ratio) and 574 mg (60%) of **25c**.

**6.5.4.1. Organomercuric 25c.** <sup>1</sup>H NMR δ 4.96 (dd, *J*=8.8, 3.7 Hz, 1H), 3.63 (dd, *J*=9.9, 5.1 Hz, 1H), 3.57–3.40 (m, 3H+OH), 2.73 (br s, 1H, OH), 2.46 (m, 1H), 2.00 (m, 1H), 1.97 (dd, *J*=11.9, 4.0 Hz, 1H), 1.76 (dd, *J*=11.9, 9.0 Hz, 1H), 1.25 (s, 9H), 1.03 (d, *J*=7.0 Hz, 3H); <sup>13</sup>C NMR δ 179.5 (s), 75.4 (d), 65.1 (t), 63.6 (t), 41.3 (d), 39.2 (s), 36.8 (d), 28.7 (t), 27.4 (q, 3C), 14.1 (q).

**6.5.4.2. Organomercuric 25'c.** <sup>1</sup>H NMR δ 4.34 (dd, *J*=11.0, 4.8 Hz, 1H), 4.07 (dd, *J*=11.0, 4.0 Hz, 1H), 3.87–3.62 (m, 3H), 2.39 (m, 1H), 2.01–1.89 (m, 1H), 1.79–1.58 (m, 2H), 1.22 (s, 9H), 0.95 (d, *J*=7.0 Hz, 3H); <sup>13</sup>C NMR δ 179.6 (s), 73.2 (d), 67.4 (t), 66.9 (t), 40.2 (d), 38.9 (s), 36.4 (d), 27.2 (q, 3C), 25.5 (t), 13.8 (q).

**6.5.4.3. Organomercuric 25''c.** <sup>1</sup>H NMR δ 4.16 (dd, *J*=11.0, 7.3 Hz, 1H), 3.97 (dd, *J*=11.0, 6.1 Hz, 1H), 3.87–3.62 (m, 3H), 2.66 (m, 1H), 2.01–1.89 (m, 1H), 1.79–1.58 (m, 2H), 1.22 (s, 9H), 0.83 (d, *J*=7.0 Hz, 3H); <sup>13</sup>C NMR δ 179.1 (s), 75.0 (d), 68.4 (t), 67.4 (t), 39.4 (d), 38.8 (s), 36.7 (d), 27.2 (q, 3C), 26.1 (t), 13.2 (q).

According to the representative procedure, reductive demercuration of **25c** (570 mg, 1.12 mmol) and purification by flash chromatography (cyclohexane–EtOAc: 60/40–40/60) gave 227 mg (88%) of **26b** as a colorless oil. Similarly, reductive demercuration of **25'c** and **25''c** (75/25 mixture, 165 mg, 0.324 mmol) afforded, after purification by flash chromatography (cyclohexane–EtOAc: 60/40–40/60), 52 mg (70%) of a mixture of **26''b** and **26'b** (75/25 ratio).

**6.5.4.4. (2S\*,3R\*,4S\*)-3,5-Dihydroxy-2,4-dimethylpentyl 2,2-dimethylpropanoate 26''b.** IR 3400, 1730, 1710, 1290, 1170, 1030 cm<sup>-1</sup>; <sup>1</sup>H NMR δ 4.35 (dd, *J*=11.0, 5.2 Hz, 1H), 4.09 (dd, *J*=11.0, 3.7 Hz, 1H), 3.78–3.60 (m, 2H+OH), 3.56 (dd, *J*=9.7, 2.0 Hz, 1H), 3.39 (br s, 1H, OH), 2.03–1.73 (m, 2H), 1.22 (s, 9H), 0.95 (d, *J*=7.0 Hz, 3H), 0.91 (d, *J*=7.0 Hz, 3H); <sup>13</sup>C NMR δ 179.4 (s), 74.5 (d), 67.5 (t), 67.0 (t), 38.9 (s), 36.7 (d), 35.7 (d), 27.2 (q, 3C), 13.7 (q), 8.5 (q).

**6.5.5. Chemical correlation for the attribution of the relative configuration of compounds 26a, 26'a and 26b.**

**6.5.5.1. (2S\*,3S\*,4R\*)-2,4-Dimethylpentane-1,3,5-triol 27.**<sup>23</sup> To a solution of **26a** (147 mg, 0.63 mmol) in THF (5 mL) at 0 °C, was added LiAlH<sub>4</sub> (72 mg, 1.9 mmol, 3.0 equiv). After 40 min at rt, the reaction was quenched by successive addition of H<sub>2</sub>O (0.1 mL), a 15% aqueous NaOH solution (0.1 mL) and H<sub>2</sub>O (0.3 mL). After 3 h stirring at rt, the reaction mixture was filtered through Celite and the insoluble salts were thoroughly washed with boiling THF. The filtrate was concentrated under reduced pressure and the crude material was purified by flash chromatography (CH<sub>2</sub>Cl<sub>2</sub>–MeOH: 90/10) to afford 81 mg (86%) of **27** as a waxy white solid. Similarly, compound **26'a** (54 mg, 0.23 mmol) was reduced with LiAlH<sub>4</sub> (26 mg, 0.68 mmol, 3 equiv) to give 22 mg (65%) of **27**. Based on literature results,<sup>23</sup> the <sup>13</sup>C NMR data readily enabled the stereochemical assignment; <sup>13</sup>C NMR (D<sub>2</sub>O) δ 79.4 (d), 66.4 (t, 2C), 39.8 (d, 2C), 16.6 (q, 2C).

**6.5.5.2. (2S\*,4S\*)-2,4-Dimethylpentane-1,3,5-triol 28.**<sup>23</sup> Reduction of **26b** (68 mg, 0.29 mmol) with LiAlH<sub>4</sub> (22 mg, 0.58 mmol, 2.0 equiv) in THF (5 mL) at 0 °C and purification by flash chromatography (CH<sub>2</sub>Cl<sub>2</sub>–MeOH: 90/10) afforded 27 mg (68%) of **28** as waxy white solid; <sup>13</sup>C NMR (D<sub>2</sub>O) δ 75.6 (d), 67.6 (t), 67.2 (t), 40.4 (d), 39.1 (d), 15.7 (q), 11.3 (q).

## 6.5.6. Synthesis of stereotriads 33a–d from the benzyl ethers 6a–d.

**6.5.6.1. (1S\*,2S\*)-1-[(1S\*)-2-(Benzyloxy)-1-methyl-ethyl]-2-methylpropane-1,3-diol 33a**<sup>25</sup> (representative procedure) Compound **6a** (200 mg, 0.657 mmol) was oxymercured with Hg(OCOFCF<sub>3</sub>)<sub>2</sub> (560 mg, 1.31 mmol, 2.0 equiv) in CH<sub>2</sub>Cl<sub>2</sub> (7 mL) at rt for 1 h. The crude mixture of organomercuric bromides was subjected to reductive demercuration with *n*-Bu<sub>3</sub>SnH (210 μL, 0.781 mmol) and a catalytic amount of AIBN (2 mg) in THF (10 mL) for 30 min at rt. The resulting crude material was dissolved in THF (5 mL) and LiAlH<sub>4</sub> (30 mg, 0.78 mmol) was added at 0 °C. After 2 h at rt, the reaction was quenched by successive addition of H<sub>2</sub>O (0.1 mL), a 15% aqueous NaOH solution (0.1 mL) and H<sub>2</sub>O (0.3 mL) and after 2 h at rt, the resulting mixture was filtered through Celite. The insoluble salts were thoroughly washed with boiling THF and the filtrate was evaporated under reduced pressure. The crude material was purified by flash chromatography (cyclohexane–EtOAc: 50/50) to afford 59 mg (38%) of **33a** as a colorless oil; *R*<sub>f</sub> 0.25 (cyclohexane–EtOAc: 50/50); IR 3370, 1455, 1095, 1070, 1030, 990, 745, 705 cm<sup>-1</sup>; <sup>1</sup>H NMR (C<sub>6</sub>D<sub>6</sub>) δ 7.31–7.05 (m, 5H), 4.20 (s, 2H), 4.07 (d, *J* = 4.6 Hz, 1H), 3.78 (m, 1H), 3.63–3.57 (m, 2H), 3.38 (dd, *J* = 9.1, 4.8 Hz, 1H), 3.36 (m, 1H), 3.30 (dd, *J* = 9.1, 5.7 Hz, 1H), 1.84 (m, 1H), 1.72 (m, 1H), 0.88 (d, *J* = 7.0 Hz, 6H); <sup>13</sup>C NMR (C<sub>6</sub>D<sub>6</sub>) δ 139.1 (s), 129.3 (d), 128.5 (d, 2C), 128.4 (d, 2C) (overlap with solvent), 82.0 (d), 74.4 (t), 74.1 (t), 67.4 (t), 38.1 (d), 36.8 (d), 15.6 (q), 15.3 (q).

**6.5.6.2. (1S\*,2R\*)-1-[(1S\*)-2-(Benzyloxy)-1-methyl-ethyl]-2-methylpropane-1,3-diol 33b.**<sup>25</sup> This compound was synthesized from **6b** (50 mg, 0.16 mmol) according to the representative procedure. Purification by flash chromatography (cyclohexane–EtOAc: 50/50) afforded 19 mg (50%) of **33b** as a colorless oil; *R*<sub>f</sub> 0.17 (cyclohexane–EtOAc: 50/50);

IR 3330, 1430, 1110, 1070, 745, 705 cm<sup>-1</sup>; <sup>1</sup>H NMR (C<sub>6</sub>D<sub>6</sub>) δ 7.23–7.05 (m, 5H), 4.17 (s, 2H), 3.83 (br s, 1H, OH), 3.73–3.63 (m, 3H), 3.28 (dd, *J* = 9.0, 4.5 Hz, 1H), 3.21 (dd apparent t, *J* = 9.0, 8.5 Hz, 1H), 2.30 (br s, 1H, OH), 1.84 (m, 1H), 1.51 (m, 1H), 1.00 (d, *J* = 7.0 Hz, 3H), 0.52 (d, *J* = 6.9 Hz, 3H); <sup>13</sup>C NMR (C<sub>6</sub>D<sub>6</sub>) δ 138.9 (s), 129.3 (d), 128.7 (d, 2C) (overlap with solvent), 128.4 (d, 2C), 79.4 (d), 76.9 (t), 74.1 (t), 68.4 (t), 37.6 (d), 37.0 (d), 13.8 (q), 9.7 (q).

**6.5.6.3. (1S\*,2S\*)-1-[(1R\*)-2-(Benzyloxy)-1-methyl-ethyl]-2-methylpropane-1,3-diol 33c.**<sup>25</sup> This compound was synthesized from **6c** (80 mg, 0.26 mmol) according to the representative procedure. Purification by flash chromatography (cyclohexane–EtOAc: 60/40) afforded 40 mg (65%) of **33c** as a colorless oil; IR 3330, 1430, 1110, 1070, 745, 705 cm<sup>-1</sup>; <sup>1</sup>H NMR (C<sub>6</sub>D<sub>6</sub>) δ 7.25–7.06 (m, 5H), 4.26 (s, 2H), 3.83 (br s, 1H, OH), 3.70–3.58 (m, 3H + OH), 3.38 (dd, *J* = 8.9, 5.8 Hz, 1H), 3.29 (dd, *J* = 8.9, 4.8 Hz, 1H), 1.84–1.69 (m, 2H), 0.96 (d, *J* = 7.0 Hz, 3H), 0.58 (d, *J* = 6.9 Hz, 3H); <sup>13</sup>C NMR (C<sub>6</sub>D<sub>6</sub>) δ 139.4 (s), 129.2 (d), 128.4–128.0 (d, 2C + 2C, overlap with solvent), 79.2 (d), 75.8 (t), 74.1 (t), 69.2 (t), 38.3 (d), 36.4 (d), 14.1 (q), 10.3 (q).

**6.5.6.4. (1S\*,2R\*)-1-[(1R\*)-2-(Benzyloxy)-1-methyl-ethyl]-2-methylpropane-1,3-diol 33d.**<sup>25</sup> This compound was synthesized from **6d** (18 mg, 0.059 mmol) according to the representative procedure. Purification by flash chromatography (pentane–Et<sub>2</sub>O gradient: 60/40–40/60) afforded 7 mg (47%) of **33d** as a colorless oil; *R*<sub>f</sub> 0.13 (cyclohexane–EtOAc: 50/50); IR 3380, 1470, 1090, 1030, 980, 745, 705 cm<sup>-1</sup>; <sup>1</sup>H NMR (C<sub>6</sub>D<sub>6</sub>) δ 7.25–7.06 (m, 5H), 4.22 (s, 2H), 3.70 (dd apparent t, *J* = 5.1 Hz, 1H), 3.38 (d, *J* = 5.1 Hz, 2H), 3.23 (dd, *J* = 9.1, 5.4 Hz, 1H), 3.18 (dd, *J* = 9.1, 4.8 Hz, 1H), 2.35 (br s, 1H, OH), 1.84 (m, 1H), 1.65 (m, 1H), 1.30 (br s, 1H, OH), 1.07 (d, *J* = 7.0 Hz, 3H), 0.99 (d, *J* = 7.0 Hz, 3H); <sup>13</sup>C NMR (C<sub>6</sub>D<sub>6</sub>) δ 139.6 (s), 129.2 (d), 128.9 (d, 2C), 128.3 (d, 2C) (overlap with solvent), 76.5 (d), 75.1 (t), 73.9 (t), 67.7 (t), 38.7 (d), 37.4 (d), 13.4 (q), 12.2 (q).

## 6.6. Oxymercuration of cyclopropanes of type E

**6.6.1. (2R\*,3R\*,4S\*,5R\*)-1-Benzyloxy-2,4-dimethylheptane-3,5-diol 35a.** Compound **12a** (114 mg, 0.393 mmol) was oxymercured with Hg(OCOFCF<sub>3</sub>)<sub>2</sub> (352 mg, 0.825 mmol, 2.1 equiv) in CH<sub>2</sub>Cl<sub>2</sub> (4 mL) for 1 h at rt. The crude mixture of organomercuric bromides was dissolved in a mixture of THF and toluene (1/1, 6 mL) and to the resulting degassed solution [argon bubbling, 20 min] was added AIBN (2.3 mg) and *n*-Bu<sub>3</sub>SnH (0.26 mL, 0.97 mmol, 2.5 equiv). After 1 h at rt and 1 h at 55 °C, CCl<sub>4</sub> (1 mL) was added in order to destroy the excess tin hydride. The reaction mixture was diluted with a mixture of petroleum ether–CH<sub>2</sub>Cl<sub>2</sub> (75/25, 20 mL) and the resulting solution was washed with a 5% aqueous solution of KF (4 × 10 mL). The organic extracts were dried over MgSO<sub>4</sub>, filtered and concentrated under reduced pressure. The crude material was suspended in CH<sub>2</sub>Cl<sub>2</sub> and the insoluble material was removed by filtration. The filtrate was evaporated and the residual oil was purified by flash chromatography (petroleum ether–EtOAc gradient: 95/5–80/20) to afford 79 mg (65%) of a regioisomeric mixture of **34a** and **34'a** (70 mg, 0.023 mmol), which was dissolved in THF (3 mL). To the resulting solution at 0 °C, was added

LiAlH<sub>4</sub> (28 mg, 0.74 mmol, 3.3 equiv) and after 3 h at rt, the reaction was quenched by successive addition of H<sub>2</sub>O (30 μL), a 15% aqueous NaOH solution (30 μL) and H<sub>2</sub>O (120 μL). After 3 h, the resulting mixture was diluted with Et<sub>2</sub>O and filtered through Celite. The insoluble salts were thoroughly washed with boiling THF and the filtrate was evaporated under reduced pressure. The crude material was purified by flash chromatography (petroleum ether–Et<sub>2</sub>O gradient: 60/40–50/50) to afford 48 mg (80%) of **35a** as a colorless oil; IR 3350, 1085, 965, 735, 700 cm<sup>-1</sup>; <sup>1</sup>H NMR δ 7.39–7.26 (m, 5H), 4.53 (s, 2H), 4.42 (br s, 1H, OH), 3.87 (m, 1H), 3.81 (br s, 1H, OH), 3.66 (dd, *J*=9.1, 4.0 Hz, 1H), 3.58 (dd, *J*=8.3, 3.5 Hz, 1H), 3.49 (dd, *J*=9.1, 8.3 Hz, 1H), 2.17 (m, 1H), 1.72 (m, 1H), 1.57 (m, 1H), 1.39 (m, 1H), 1.02 (d, *J*=7.0 Hz, 3H), 0.93 (t, *J*=7.4 Hz, 3H), 0.83 (d, *J*=7.0 Hz, 3H); <sup>13</sup>C NMR δ 137.4 (s), 128.5 (d, 2C), 127.9 (d), 127.7 (d, 2C), 82.4 (d), 76.1 (t), 73.6 (t), 72.7 (d), 37.1 (d), 35.7 (d), 27.2 (t), 13.7 (q), 10.9 (q), 10.6 (q); MS (CI<sup>+</sup>, CH<sub>4</sub>) *m/z* (relative intensity) 267 (M+H<sup>+</sup>, 100), 249 (15), 231 (13), 157 (12), 141 (28); HRMS (CI<sup>+</sup>, CH<sub>4</sub>) Calcd for C<sub>16</sub>H<sub>27</sub>O<sub>3</sub> (M+H<sup>+</sup>): 267.1960. Found: 267.1955.

**6.6.2. (1R\*,2S\*,3R\*,4S\*)-5-Benzyloxy-1-ethyl-3-hydroxy-2,4-dimethylpentyl acetate 34c and (1R\*,2S\*,3R\*)-1-[(1S\*)-2-benzyloxy-1-methylethyl]-3-hydroxy-2,4-dimethylpentyl acetate 34'c.** Compound **12c** (107 mg, 0.368 mmol) was subjected to the oxymercuration–reductive demercuration procedure. <sup>1</sup>H NMR analysis of the crude material indicated the formation of regioisomeric mixture of **34c** and **34'c** (75/25 ratio). Purification by flash chromatography (CH<sub>2</sub>Cl<sub>2</sub>–Et<sub>2</sub>O: 97/3–96/4) afforded 33 mg (29%) of **34c** and 16 mg (14%) of **34'c** as colorless oils.

*Major regioisomer (34c).* IR 3510, 1710, 1250, 1100, 1020, 1015, 955, 885, 740, 700 cm<sup>-1</sup>; <sup>1</sup>H NMR δ 7.38–7.25 (m, 5H), 5.21 (ddd, *J*=9.2, 4.8, 1.7 Hz, 1H), 4.53 (d, *J*=12.1 Hz, 1H), 4.49 (d, *J*=12.1 Hz, 1H), 3.56 (dd, *J*=9.0, 6.8 Hz, 1H), 3.46 (dd, *J*=9.0, 5.7 Hz, 1H), 3.41–3.27 (m, 2H, 1H+OH), 2.09 (s, 3H), 1.96 (m, 1H), 1.79–1.65 (m, 2H), 1.49 (m, 1H), 0.91 (t, *J*=7.4 Hz, 3H), 0.89 (d, *J*=7.0 Hz, 3H), 0.81 (d, *J*=7.0 Hz, 3H); <sup>13</sup>C NMR δ 172.4 (s), 138.6 (s), 128.3 (d, 2C), 127.5 (d, 3C), 75.7 (d), 74.5 (t), 73.2 (t), 71.5 (d), 39.6 (d), 34.7 (d), 25.4 (t), 21.0 (q), 10.5 (q), 9.2 (q), 8.2 (q); MS-EI *m/z* (relative intensity) 248 (M–AcOH<sup>+</sup>, 1), 202 (4), 160 (9), 159 (9), 108 (15), 107 (31), 99 (13), 92 (11), 91 (100), 70 (10), 69 (12).

*Minor regioisomer (34'c).* IR 3520, 1715, 1250, 1095, 1020, 965, 955, 740, 700 cm<sup>-1</sup>; <sup>1</sup>H NMR δ 7.38–7.25 (m, 5H), 5.08 (dd, *J*=10.3, 2.6 Hz, 1H), 4.50 (d, *J*=11.8 Hz, 1H), 4.44 (d, *J*=11.8 Hz, 1H), 3.34 (m, 1H), 3.27 (d, *J*=7.0 Hz, 2H), 2.79 (br d, *J*=3.3 Hz, 1H, OH), 2.19 (m, 1H), 2.03 (s, 3H), 1.73–1.53 (m, 2H), 1.32 (m, 1H), 0.93 (t, *J*=7.5 Hz, 3H), 0.91 (d, *J*=7.0 Hz, 3H), 0.85 (d, *J*=7.0 Hz, 3H); <sup>13</sup>C NMR δ 172.4 (s), 138.2 (s), 128.4 (d, 2C), 127.8 (d, 2C), 127.6 (d), 75.5 (d), 73.3 (t), 72.8 (t), 71.0 (d), 38.6 (d), 34.2 (d), 26.9 (t), 20.8 (q), 11.1 (q), 10.0 (q), 8.4 (q); MS-EI *m/z* (relative intensity) 248 (M–AcOH<sup>+</sup>, 1), 202 (3), 160 (9), 159 (9), 108 (14), 107 (30), 99 (12), 92 (11), 91 (100), 69 (12).

**6.6.3. (2S\*,3R\*,4S\*,5R\*)-1-Benzyloxy-2,4-dimethylheptane-3,5-diol 35c.** To a solution of **34c** (30 mg, 0.097 mmol) in THF (2 mL) at 0 °C, was added LiAlH<sub>4</sub>

(8 mg, 0.2 mmol, 2.1 equiv). After 1 h at rt, and usual work-up, purification of the crude material by flash chromatography (petroleum ether–Et<sub>2</sub>O gradient: 70/30–50/50) afforded 19 mg (73%) of **35c** as a colorless oil. Similarly, reduction of **34'c** (13 mg, 0.042 mmol) with LiAlH<sub>4</sub> and purification by flash chromatography (petroleum ether–Et<sub>2</sub>O gradient: 70/30–50/50) afforded 5 mg (45%) of **35c**; IR 3400, 1095, 1070, 970, 735, 700 cm<sup>-1</sup>; <sup>1</sup>H NMR δ 7.39–7.27 (m, 5H), 4.54 (d, *J*=12.1 Hz, 1H), 4.49 (d, *J*=12.1 Hz, 1H), 3.83 (dd, *J*=9.2, 2.6 Hz, 1H), 3.71 (m, 1H), 3.60 (dd, *J*=9.0, 4.0 Hz, 1H), 3.55 (dd, *J*=9.0, 4.8 Hz, 1H), 3.33 (br s, 1H, OH), 2.82 (br s, 1H, OH), 1.93–1.77 (m, 2H), 1.61–1.38 (m, 2H), 1.01 (d, *J*=7.0 Hz, 3H), 0.99 (t, *J*=7.4 Hz, 3H), 0.79 (d, *J*=7.4 Hz, 3H); <sup>13</sup>C NMR δ 138.0 (s), 128.4 (d, 2C), 127.7 (d), 127.6 (d, 2C), 76.6 (d), 75.7 (t), 75.6 (d), 73.5 (t), 39.4 (d), 35.3 (d), 25.8 (t), 11.8 (q), 11.1 (q), 9.9 (q); MS (CI<sup>+</sup>, CH<sub>4</sub>) *m/z* (relative intensity) 267 (M+H<sup>+</sup>, 56), 249 (22), 231 (22), 157 (31), 141 (100), 125 (25), 123 (31), 119 (27); HRMS (CI<sup>+</sup>, CH<sub>4</sub>) Calcd for C<sub>16</sub>H<sub>27</sub>O<sub>3</sub> (M+H<sup>+</sup>): 267.1960. Found: 267.1965.

**6.6.4. (4R\*,5S\*,6R\*)-4-[(1R\*)-2-(Benzyloxy)-1-methylethyl]-6-ethyl-2,2,5-trimethyl-1,3-dioxane 36a.** To a solution of **35a** (20 mg, 0.075 mmol) in a mixture of acetone (1 mL) and 2,2-dimethoxypropane (1 mL) was added a catalytic amount of CSA (3 mg). After 6 h at rt, the reaction mixture was hydrolyzed with a saturated aqueous NaHCO<sub>3</sub> solution and extracted with Et<sub>2</sub>O. The combined extracts were dried over MgSO<sub>4</sub>, filtered and concentrated under reduced pressure to afford 22 mg (96%) of **36a** as a colorless oil; IR 1220, 1180, 1150, 1095, 1020, 990, 880, 735, 700 cm<sup>-1</sup>; <sup>1</sup>H NMR δ 7.36–7.26 (m, 5H), 4.54 (d, *J*=12.0 Hz, 1H), 4.49 (d, *J*=12.0 Hz, 1H), 3.66 (m, 1H), 3.61 (dd, *J*=9.2, 4.8 Hz, 1H), 3.37 (dd, *J*=9.2, 7.0 Hz, 1H), 3.26 (dd, *J*=7.0, 5.3 Hz, 1H), 1.96 (m, 1H), 1.84 (m, 1H), 1.70–1.33 (m, 2H), 1.32 (s, 3H), 1.31 (s, 3H), 1.04 (d, *J*=7.0 Hz, 3H), 0.92 (t, *J*=7.4 Hz, 3H), 0.85 (d, *J*=7.0 Hz, 3H); <sup>13</sup>C NMR δ 138.8 (s), 128.3 (d, 2C), 127.5 (d, 2C), 127.4 (d), 100.2 (s), 76.6 (d), 73.1 (t), 72.4 (t), 71.0 (d), 37.8 (d), 36.5 (d), 25.4 (q), 23.6 (t and q, 2C), 14.3 (q), 12.4 (q), 10.5 (q); MS (CI<sup>+</sup>, CH<sub>4</sub>) *m/z* (relative intensity) 307 (M+H<sup>+</sup>, 62), 291 (22), 249 (100), 231 (35), 157 (21), 141 (46); HRMS (CI<sup>+</sup>, CH<sub>4</sub>) Calcd for C<sub>19</sub>H<sub>31</sub>O<sub>3</sub> (M+H<sup>+</sup>): 307.2273. Found: 307.2272.

**6.6.5. (4R\*,5S\*,6R\*)-4-[(1S\*)-2-Benzyloxy-1-methylethyl]-6-ethyl-2,2,5-trimethyl-1,3-dioxane 36c.** Acetonide formation from **35c** (19 mg, 0.071 mmol) provided 20 mg (91%) of **36c** as a colorless oil; IR 1225, 1180, 1150, 1095, 1020, 980, 880, 730, 700 cm<sup>-1</sup>; <sup>1</sup>H NMR δ 7.36–7.26 (m, 5H), 4.52 (s, 2H), 3.65 (dt, *J*=8.5, 4.8 Hz, 1H), 3.50–3.43 (m, 2H), 3.36 (dd, *J*=9.0, 6.1 Hz, 1H), 1.93–1.77 (m, 2H), 1.51–1.22 (m, 2H), 1.31 (s, 6H), 0.95 (d, *J*=7.0 Hz, 3H), 0.93 (t, *J*=7.4 Hz, 3H), 0.83 (d, *J*=6.6 Hz, 3H); <sup>13</sup>C NMR δ 138.7 (s), 128.3 (d, 2C), 127.6 (d, 2C), 127.4 (d), 100.2 (s), 74.1 (d), 73.1 (t, 2C), 71.2 (d), 36.4 (d), 36.3 (d), 25.0 (q), 23.7 (q), 23.6 (t), 11.8 (q), 11.2 (q), 10.6 (q); MS EI *m/z* (relative intensity) 291 (M–Me<sup>+</sup>, 6), 248 (M–Me<sub>2</sub>C=O<sup>+</sup>, 6), 190 (9), 179 (12), 107 (18), 92 (10), 91 (100), 69 (19), 59 (24).

**6.6.6. (2R\*,3R\*,4S\*,5R\*,6S\*)-7-Benzyloxy-2,4,6-trimethylheptane-1,3,5-triol 37.**<sup>27</sup> Compound **15** (125 mg, 0.345 mmol) was subjected to oxymercuration–reductive



demercuration sequence. The intermediate regioisomeric mixture of acetates (ratio not determined) was reduced with  $\text{LiAlH}_4$  (45 mg, 1.2 mmol, 8 equiv) in THF (2 mL) for 2 h at rt and purification by flash chromatography (petroleum ether–EtOAc: 20/80) gave 25 mg (25% from **15**) of **37** as a colorless oil; IR 3360, 1080, 1025, 970, 735, 700  $\text{cm}^{-1}$ ;  $^1\text{H}$  NMR  $\delta$  7.39–7.25 (m, 5H), 4.51 (s, 2H), 3.94 (dd,  $J=9.7$ , 2.0 Hz, 1H), 3.74 (dd,  $J=7.5$  and 3.5 Hz, 1H), 3.66 (d,  $J=5.9$  Hz, 2H), 3.57 (dd,  $J=8.8$ , 4.0 Hz, 1H), 3.53 (dd,  $J=8.8$ , 4.4 Hz, 1H), 3.60–3.49 (m, 2H, 2OH), 3.29 (br s, 1H, OH), 1.99–1.84 (m, 2H), 1.74 (m, 1H), 1.04 (d,  $J=7.0$  Hz, 3H), 0.89 (d,  $J=7.0$  Hz, 3H), 0.71 (d,  $J=7.0$  Hz, 3H);  $^{13}\text{C}$  NMR  $\delta$  137.9 (s), 128.4 (d, 2C), 127.8 (d), 127.7 (d, 2C), 77.2 (d), 76.8 (d), 75.4 (t), 73.5 (t), 69.5 (t), 37.1 (d), 37.0 (d), 35.6 (d), 13.2 (q), 11.0 (q), 10.2 (q).

**6.6.7. (2R\*,3R\*,4R\*,5R\*,6S\*)-7-Benzoyloxy-3,5-dihydroxy-2,4,6-trimethyl 2,2-dimethylpropanoate 38.** To a solution of the triol **37** (10 mg, 0.034 mmol) in  $\text{CH}_2\text{Cl}_2$  (1 mL) were successively added at 0 °C,  $\text{Et}_3\text{N}$  (60  $\mu\text{L}$ , 0.43 mmol, 13 equiv) and  $\text{PivCl}$  (50  $\mu\text{L}$ , 0.40 mmol, 12 equiv). After 12 h at 0 °C, additional quantities of  $\text{Et}_3\text{N}$  (30 mL, 0.21 mmol, 6 equiv) and  $\text{PivCl}$  (20  $\mu\text{L}$ , 0.16 mmol, 4.8 equiv) were added. After a further 12 h at 0 °C, the reaction mixture was evaporated under reduced pressure and the residual oil was dissolved in a mixture of acetone (1 mL) and 2,2-dimethoxypropane (1 mL). A catalytic amount of CSA (2 mg) was added and after 1 h at rt, the reaction mixture was hydrolyzed with a saturated aqueous  $\text{NaHCO}_3$  solution and extracted with ether. The combined extracts were dried over  $\text{MgSO}_4$ , filtered and concentrated under reduced pressure. The residue was purified by flash chromatography (petroleum ether–EtOAc: 95/5) to afford 9 mg (64%) of **38** as a colorless oil; IR 1730, 1480, 1280, 1225, 1160, 730, 700  $\text{cm}^{-1}$ ;  $^1\text{H}$  NMR  $\delta$  7.35–7.26 (m, 5H), 4.53 (d,  $J=12.1$  Hz, 1H), 4.48 (d,  $J=12.1$  Hz, 1H), 4.19 (dd,  $J=10.7$ , 3.3 Hz, 1H), 4.02 (dd,  $J=10.7$ , 5.9 Hz, 1H), 3.55 (dd,  $J=10.9$ , 4.2 Hz, 1H), 3.48–3.41 (m, 2H), 3.35 (dd,  $J=8.8$ , 5.9 Hz, 1H), 1.97–1.83 (m, 3H), 1.27 (s, 3H), 1.25 (s, 3H), 1.21 (s, 9H), 0.95 (d,  $J=7.0$  Hz, 3H), 0.90 (d,  $J=7.0$  Hz, 3H), 0.87 (d,  $J=6.6$  Hz, 3H);  $^{13}\text{C}$  NMR  $\delta$  178.6 (s), 138.7 (s), 128.3 (d, 2C), 127.6 (d, 2C), 127.5 (d), 100.5 (s), 74.4 (d), 73.1 (t), 72.9 (t), 70.0 (d), 66.3 (t), 38.9 (s), 366.8 (d), 34.8 (d), 33.0 (d), 27.3 (q, 3C), 25.0 (q), 23.4 (q), 12.9 (q), 11.8 (q), 11.3 (q); MS ( $\text{CI}^+$ ,  $\text{CH}_4$ )  $m/z$  (relative intensity) 421 ( $\text{M}+\text{H}^+$ , 52), 363 (100), 345 (39), 261 (76), 255 (97), 173 (61), 171 (22); HRMS ( $\text{CI}^+$ ,  $\text{CH}_4$ ) Calcd for  $\text{C}_{25}\text{H}_{41}\text{O}_5$  ( $\text{M}+\text{H}^+$ ): 421.2954. Found: 421.2959.

## 6.7. Oxymercuration of cyclopropanes of type G and H

**6.7.1. Oxymercuration of cyclopropane 17.** Compound **17** (125 mg, 0.516 mmol) was subjected to the oxymercuration–reductive demercuration sequence and, after purification by flash chromatography (petroleum ether–EtOAc gradient: 80/20–0/100), 42 mg (32%) of **39**, and 38 mg (29%) of **39'** were obtained as colorless oils.

**6.7.1.1. (2S\*,3S\*,4S\*,5R\*)-3,5-Dihydroxy-2,4-dimethylheptyl 2,2-dimethylpropanoate 39.**  $R_f$  0.42 (petroleum ether–EtOAc: 60/40); IR 3440, 1720, 1290, 1170, 970  $\text{cm}^{-1}$ ;  $^1\text{H}$  NMR  $\delta$  4.43 (dd,  $J=11.2$ , 4.5 Hz, 1H), 4.02 (dd, 11.2, 3.7 Hz, 1H), 3.90 (br s, 1H, OH), 3.72 (m, 1H), 3.47 (dd,  $J=$

9.9, 1.7 Hz, 1H), 3.45 (br s, 1H, OH), 1.91 (m, 1H), 1.67–1.39 (m, 3H), 1.22 (s, 9H), 0.95 (t,  $J=7.4$  Hz, 3H), 0.91 (d,  $J=7.0$  Hz, 3H), 0.90 (d,  $J=7.1$  Hz, 3H);  $^{13}\text{C}$  NMR  $\delta$  179.6 (s), 78.8 (d), 78.0 (d), 66.8 (t), 39.0 (s), 36.8 (d), 36.7 (d), 28.0 (t), 27.2 (q, 3C), 13.7 (q), 10.5 (q), 3.9 (q); MS ( $\text{CI}^+$ ,  $\text{CH}_4$ )  $m/z$  (relative intensity) 261 ( $\text{M}+\text{H}^+$ , 100), 243 (18), 225 (14), 173 (15), 159 (11), 141 (68), 123 (38); HRMS ( $\text{CI}^+$ ,  $\text{CH}_4$ ) Calcd for  $\text{C}_{14}\text{H}_{29}\text{O}_4$  ( $\text{M}+\text{H}^+$ ): 261.2066. Found: 261.2065.

**6.7.1.2. (1R\*,2R\*,3S\*,4S\*)-1-Ethyl-3,5-dihydroxy-2,4-dimethylpentyl 2,2-dimethylpropanoate 39'.**  $R_f$  0.17 (petroleum ether–EtOAc: 60/40); IR 3440, 1730, 1290, 1170  $\text{cm}^{-1}$ ;  $^1\text{H}$  NMR  $\delta$  4.84 (ddd,  $J=7.3$ , 5.5, 4.8 Hz, 1H), 3.71 (dd,  $J=11.0$ , 4.0 Hz, 1H), 3.67 (dd,  $J=11.0$ , 3.7 Hz, 1H), 3.61 (dd,  $J=8.6$ , 2.8 Hz, 1H), 3.30–3.00 (br m, 2H, 2OH), 1.92–1.75 (m, 2H), 1.73–1.61 (m, 2H), 1.22 (s, 9H), 0.91 (d,  $J=7.0$  Hz, 3H), 0.88 (t,  $J=7.7$  Hz, 3H), 0.82 (d,  $J=7.0$  Hz, 3H);  $^{13}\text{C}$  NMR  $\delta$  179.0 (s), 79.2 (d), 78.1 (d), 68.4 (t), 39.1 (s), 38.7 (d), 37.3 (d), 27.2 (q, 3C), 25.7 (t), 13.9 (q), 9.8 (q), 7.3 (q); MS ( $\text{CI}^+$ ,  $\text{CH}_4$ )  $m/z$  (relative intensity) 261 ( $\text{M}+\text{H}^+$ , 100), 243 (23), 159 (31), 141 (35), 124 (14), 123 (26); HRMS ( $\text{CI}^+$ ,  $\text{CH}_4$ ) Calcd for  $\text{C}_{14}\text{H}_{29}\text{O}_4$  ( $\text{M}+\text{H}^+$ ): 261.2066. Found: 261.2065.

**6.7.1.3. (2S\*)-2-((4S\*,5S\*,6R\*)-6-Ethyl-2,2,5-trimethyl-1,3-dioxan-4-yl)propyl 2,2-dimethylpropanoate 40.** Acetonide formation from diol **39** (25 mg, 0.096 mmol) provided, after purification by flash chromatography (petroleum ether–EtOAc: 95/5), 20 mg (69%) of **40** as a colorless oil; IR 1730, 1285, 1200, 1160, 1020, 975, 865  $\text{cm}^{-1}$ ;  $^1\text{H}$  NMR  $\delta$  4.13 (dd,  $J=10.7$ , 3.3 Hz, 1H), 4.07 (dd,  $J=10.7$ , 5.5 Hz, 1H), 3.74 (m, 1H), 3.65 (dd,  $J=10.1$ , 2.0 Hz, 1H), 1.92 (m, 1H), 1.62–1.33 (m, 3H), 1.37 (s, 6H), 1.21 (s, 9H), 0.90 (t,  $J=7.4$  Hz, 3H), 0.89 (d,  $J=7.4$  Hz, 3H), 0.83 (d,  $J=7.0$  Hz, 3H);  $^{13}\text{C}$  NMR  $\delta$  178.6 (s), 98.8 (s), 75.1 (d), 73.8 (d), 66.2 (t), 38.9 (s), 34.3 (d), 31.9 (d), 29.9 (q), 27.3 (q, 3C), 25.7 (t), 19.5 (q), 12.2 (q), 9.8 (q), 4.2 (q); MS-EI  $m/z$  (relative intensity) 285 ( $\text{M}-\text{Me}^+$ , 53), 242 ( $\text{M}-\text{Me}_2\text{C}=\text{O}^+$ , 1), 173 (28), 141 (20), 123 (100), 85 (38), 82 (85), 70 (19), 59 (51), 57 (79), 55 (15); HRMS ( $\text{CI}^+$ ,  $\text{CH}_4$ ) Calcd for  $\text{C}_{17}\text{H}_{33}\text{O}_4$  ( $\text{M}+\text{H}^+$ ): 301.2379. Found: 301.2385.

**6.7.1.4. (1R\*,2S\*)-1-Ethyl-2-((4S\*,5S\*)-2,2,5-trimethyl-1,3-dioxan-4-yl)propyl 2,2-dimethylpropanoate 40'.** Acetonide formation from diol **39'** (10 mg, 0.038 mmol) provided, after purification by flash chromatography (petroleum ether–EtOAc: 94/6), 4 mg (35%) of **40'**; IR 1730, 1285, 1200, 1170  $\text{cm}^{-1}$ ;  $^1\text{H}$  NMR  $\delta$  4.85 (m, 1H), 3.70 (dd,  $J=11.4$ , 5.0 Hz, 1H), 3.61 (dd,  $J=10.3$ , 1.8 Hz, 1H), 3.51 (dd, apparent t,  $J=11.4$  Hz, 1H), 1.92–1.79 (m, 2H), 1.73–1.50 (m, 2H), 1.42 (s, 3H), 1.34 (s, 3H), 1.22 (s, 9H), 0.91 (d,  $J=7.0$  Hz, 3H), 0.86 (t,  $J=7.5$  Hz, 3H), 0.70 (d,  $J=6.6$  Hz, 3H);  $^{13}\text{C}$  NMR  $\delta$  177.9 (s), 97.9 (s), 77.2 (d), 74.7 (d), 66.3 (t), 38.9 (s), 36.4 (d), 30.6 (d), 29.7 (q), 27.3 (q, 3C), 24.1 (t), 18.8 (q), 12.4 (q), 9.5 (q), 8.8 (q); MS-EI  $m/z$  (relative intensity) 285 ( $\text{M}-\text{Me}^+$ , 46), 242 ( $\text{M}-\text{Me}_2\text{C}=\text{O}^+$ , 4), 201 (35), 183 (11), 141 (26), 140 (11), 129 (44), 123 (84), 103 (46), 99 (34), 97 (10), 85 (53), 81 (12), 71 (22), 70 (14), 69 (16), 59 (82), 57 (100), 55 (13); HRMS ( $\text{CI}^+$ ,  $\text{CH}_4$ ) Calcd for  $\text{C}_{17}\text{H}_{33}\text{O}_4$  ( $\text{M}+\text{H}^+$ ): 301.2379. Found: 301.2379.

**6.7.2. Oxymercuration of cyclopropane 24.** Compound **24** (55 mg, 0.15 mmol) was subjected to the oxymercuration–reductive demercuration procedures. After purification by flash chromatography (petroleum ether–EtOAc gradient: 80/20–0/100), 21 mg (36%) of **45**, 7 mg (12%) of **44** and 23 mg (40%) of **43** were obtained as colorless oils (88% combined yield from **24**).

**6.7.2.1. (2R\*,3R\*,5S\*,6S\*)-7-(2,2-Dimethylpropanoyloxy)-3,5-dihydroxy-2,4,6-trimethylheptyl 2,2-dimethylpropanoate 45.**  $R_f$  0.45 (petroleum ether–EtOAc: 70/30); IR 3420, 1725, 1700, 1285, 1175, 1065, 970  $\text{cm}^{-1}$ ;  $^1\text{H}$  NMR  $\delta$  4.33 (dd,  $J=11.1$ , 5.0 Hz, 2H), 4.03 (dd,  $J=11.1$ , 3.7 Hz, 2H), 3.98 (br s, 2H, 2OH), 3.41 (m, 2H), 1.91 (m, 2H), 1.74 (m, 1H), 1.17 (s, 18H), 0.86 (d,  $J=7.0$  Hz, 9H);  $^{13}\text{C}$  NMR  $\delta$  179.3 (s, 2C), 78.3 (d, 2C), 66.8 (t, 2C), 39.0 (s, 2C), 36.8 (d, 2C), 34.1 (d), 27.2 (q, 6C), 13.7 (q, 2C), 3.8 (q); MS ( $\text{CI}^+$ ,  $\text{CH}_4$ )  $m/z$  (relative intensity) 375 ( $\text{M}+\text{H}^+$ , 81), 357 (52), 339 (12), 273 (28), 255 (22), 173 (55), 153 (100), 135 (41), 103 (53); HRMS ( $\text{CI}^+$ ,  $\text{CH}_4$ ) Calcd for  $\text{C}_{20}\text{H}_{39}\text{O}_6$  ( $\text{M}+\text{H}^+$ ): 375.2747. Found: 375.2744.

**6.7.2.2. (2R\*,3R\*,4S\*,5S\*,6S\*)-5-(2,2-Dimethylpropanoyloxy)-3,7-dihydroxy-2,4,6-trimethylheptyl 2,2-dimethylpropanoate 44.**  $R_f$  0.35 (petroleum ether–EtOAc: 70/30); IR 3420, 1725, 1700, 1285, 1175, 970  $\text{cm}^{-1}$ ;  $^1\text{H}$  NMR  $\delta$  4.96 (dd,  $J=8.1$ , 4.0 Hz, 1H), 4.27 (dd,  $J=11.1$ , 5.2 Hz, 1H), 4.11 (dd,  $J=11.1$ , 3.9 Hz, 1H), 3.52 (m, 2H), 3.41 (dd,  $J=8.1$ , 3.7 Hz, 1H), 2.41 (br s, 1H, OH), 2.07–1.86 (m, 3H), 1.63 (br s, 1H, OH), 1.24 (s, 9H), 1.22 (s, 9H), 1.03 (d,  $J=7.0$  Hz, 3H), 0.96 (d,  $J=6.6$  Hz, 6H);  $^{13}\text{C}$  NMR  $\delta$  179.3 (s), 178.9 (s), 77.4 (d), 75.3 (d), 66.4 (t), 63.8 (t), 39.2 (s), 38.9 (s), 37.5 (d), 36.3 (d), 36.2 (d), 27.3 (q, 3C), 27.2 (q, 3C), 14.3 (q), 14.2 (q), 7.5 (q).

**6.7.2.3. (2R\*,3R\*,4R\*,5S\*,6S\*)-3-(2,2-Dimethylpropanoyloxy)-5,7-dihydroxy-2,4,6-trimethylheptyl 2,2-dimethylpropanoate 43.**  $R_f$  0.18 (petroleum ether–EtOAc: 70/30); IR 3420, 1725, 1700, 1290, 1175, 1030, 1070, 970  $\text{cm}^{-1}$ ;  $^1\text{H}$  NMR  $\delta$  4.85 (dd,  $J=7.0$ , 4.0 Hz, 1H), 4.15 (dd,  $J=11.0$ , 4.0 Hz, 1H), 3.91 (dd,  $J=11.0$ , 7.0 Hz, 1H), 3.68 (m, 2H), 3.60 (dd,  $J=8.8$ , 2.6 Hz, 1H), 3.38–3.15 (m, 2H, OH), 2.20 (m, 1H), 2.03 (m, 1H), 1.88 (m, 1H), 1.22 (s, 9H), 1.20 (s, 9H), 1.02 (d,  $J=6.6$  Hz, 3H), 0.89 (d,  $J=7.0$  Hz, 3H), 0.84 (d,  $J=6.6$  Hz, 3H);  $^{13}\text{C}$  NMR  $\delta$  179.2 (s), 178.4 (s), 80.0 (d), 77.3 (d), 68.4 (t), 65.0 (t), 39.3 (s), 38.9 (s), 37.4 (d), 37.2 (d), 36.0 (d), 27.2 (q, 6C), 14.6 (q), 13.9 (q), 7.2 (q).

**6.7.2.4. (1S\*,2R\*)-[(1R\*)-1-((4S\*,5S\*)-2,2,5-Trimethyl-[1,3]dioxan-4-yl)ethyl]-3-(2,2-dimethylpropanoyloxy)-2-methylpropyl 2,2-dimethylpropanoate 46.** Acetonide formation from diol **43** (7 mg, 0.02 mmol) provided, after purification by flash chromatography (petroleum ether–EtOAc: 90/10), 6 mg (78%) of **46** as a colorless oil; IR 1725, 1280, 1200, 1150  $\text{cm}^{-1}$ ;  $^1\text{H}$  NMR  $\delta$  5.01 (dd,  $J=6.8$ , 4.6 Hz, 1H), 4.33 (dd,  $J=11.0$ , 3.9 Hz, 1H), 3.79–3.67 (m, 2H), 3.70 (dd,  $J=11.8$ , 5.2 Hz, 1H), 3.56 (dd, apparent t,  $J=11.2$  Hz, 1H), 2.17 (m, 1H), 1.99 (td,  $J=6.8$ , 2.2 Hz, 1H), 1.86 (m, 1H), 1.40 (s, 3H), 1.34 (s, 3H), 1.23 (s, 9H), 1.22 (s, 9H), 0.97 (d,  $J=7.0$  Hz, 3H), 0.90 (d,  $J=6.6$  Hz, 3H), 0.75 (d,  $J=6.6$  Hz, 3H);  $^{13}\text{C}$  NMR  $\delta$  178.5 (s), 177.4 (s), 98.1 (s), 77.2 (d), 75.7 (d), 66.2 (t), 65.2

(t), 39.1 (s), 38.8 (s), 35.3 (d), 34.3 (d), 30.7 (d), 29.7 (q), 27.4 (q, 3C), 27.2 (q, 3C), 18.7 (q), 15.2 (q), 12.2 (q), 8.7 (q); MS ( $\text{CI}^+$ ,  $\text{CH}_4$ )  $m/z$  (relative intensity) 415 ( $\text{M}+\text{H}^+$ , 10), 357 (100), 313 (17), 255 (21), 153 (14); HRMS ( $\text{CI}^+$ ,  $\text{CH}_4$ ) Calcd for  $\text{C}_{23}\text{H}_{43}\text{O}_6$  ( $\text{M}+\text{H}^+$ ): 415.3060. Found: 415.3063.

**6.7.2.5. (2R\*,3R\*,4S\*,5S\*,6S\*)-5,7-Bis(2,2-dimethylpropanoyloxy)-3-hydroxy-2,4,6-trimethylheptyl 2,2-dimethylpropanoate 47.** To a mixture of **43** (13 mg, 0.035 mmol) and **44** (6 mg, 0.02 mmol) and DMAP (107 mg, 0.876 mmol, 17 equiv) in  $\text{CH}_2\text{Cl}_2$  (2 mL) at rt, was added PivCl (80  $\mu\text{L}$ , 0.65 mmol, 13 equiv). After 15 h at rt, the reaction mixture was hydrolyzed with a saturated aqueous  $\text{NH}_4\text{Cl}$  solution and extracted with  $\text{CH}_2\text{Cl}_2$ . The combined extracts were dried over  $\text{MgSO}_4$ , filtered and concentrated under reduced pressure. The residue was purified by flash chromatography (petroleum ether–EtOAc: 75/25) to afford 21 mg (93%) of **47** as a colorless oil; IR 3500, 1725, 1280, 1155  $\text{cm}^{-1}$ ;  $^1\text{H}$  NMR  $\delta$  4.97 (dd,  $J=6.1$ , 5.3 Hz, 1H), 4.29 (dd,  $J=11.0$ , 5.2 Hz, 1H), 4.18–4.09 (m, 2H), 3.88 (dd,  $J=11.0$ , 7.7 Hz, 1H), 3.44 (ddd,  $J=8.8$ , 4.8, 3.0 Hz, 1H), 2.64 (d,  $J=4.8$  Hz, 1H, OH), 2.20 (m, 1H), 2.04–1.89 (m, 2H), 1.22 (s, 9H), 1.21 (s, 9H), 1.20 (s, 9H), 1.00 (d,  $J=6.6$  Hz, 3H), 0.95 (d,  $J=7.0$  Hz, 3H), 0.88 (d,  $J=6.6$  Hz, 3H);  $^{13}\text{C}$  NMR  $\delta$  179.0 (s), 178.5 (s), 178.4 (s), 77.2 (d), 74.3 (d), 66.7 (t), 65.0 (t), 39.2 (s), 38.9 (s), 38.8 (s), 36.4 (d, 2C), 35.1 (d), 27.3 (q, 6C), 27.2 (q, 3C), 14.8 (q), 14.1 (q), 7.4 (q); MS ( $\text{CI}^+$ ,  $\text{CH}_4$ )  $m/z$  (relative intensity) 459 ( $\text{M}+\text{H}^+$ , 24), 441 (27), 357 (100), 339 (21), 255 (22), 213 (13), 173 (29), 153 (72), 135 (30), 103 (51); HRMS ( $\text{CI}^+$ ,  $\text{CH}_4$ ) Calcd for  $\text{C}_{25}\text{H}_{47}\text{O}_7$  ( $\text{M}+\text{H}^+$ ): 459.3324. Found: 459.3324.

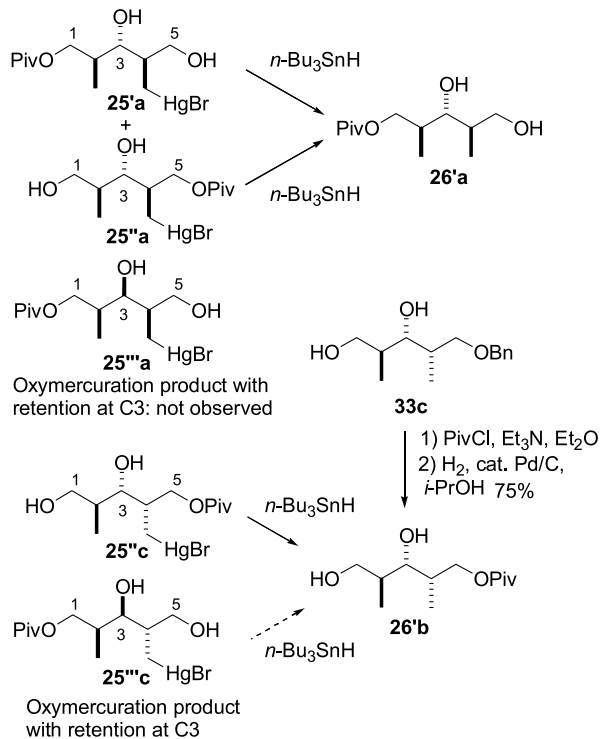
## Acknowledgements

M. D. and N. B. thank the MRES for a grant.

## References and notes

- (a) O'Hagan, D. The polyketide metabolites; Ellis Horwood: New York, 1991. (b) Sankawa, U., Barton, D. H. R., Nakanishi, K., Meth-Cohn, O., Eds.; Comprehensive natural products chemistry; Elsevier: New York, 1999; Vol. 1. (c) Davies-Coleman, M. T.; Garson, M. J. *Nat. Prod. Rep.* **1998**, *15*, 477–493. (d) Henkel, T.; Brunne, R. M.; Müller, H.; Reichel, F. *Angew. Chem., Int. Ed.* **1999**, *38*, 643–647. (e) Rohr, J. *Angew. Chem., Int. Ed.* **2000**, *39*, 2847–2849.
- For some examples, see the following articles and references therein: (a) Vogel, P.; Gerber-Lemaire, S.; Carmona, A. T.; Meilert, K. T.; Schwenter, M.-E. *Pure Appl. Chem.* **2005**, *77*, 131–137. (b) Turks, M.; Huang, X.; Vogel, P. *Chem. Eur. J.* **2005**, *11*, 465–476. (c) Falder, L. D.; Carreira, E. M. *Org. Lett.* **2004**, *6*, 2485–2488. (d) Turks, M.; Fonquerne, F.; Vogel, P. *Org. Lett.* **2004**, *6*, 1053–1056. (e) Calter, M. A.; Song, W.; Zhou, J. J. *Org. Chem.* **2004**, *69*, 1270–1275. (f) Mochirian, P.; Cardinal-David, B.; Guérin, B.; Prévost, M.; Guindon, Y. *Tetrahedron Lett.* **2002**, *43*, 7067–7071. (g) Breit, B.; Zahn, S. K. *J. Org. Chem.* **2001**, *66*, 4870–4877. (h) Arjona, O.;

- Menchaca, R.; Plumet, J. *J. Org. Chem.* **2001**, *66*, 2400–2413.
- (i) Calter, M. A.; Guo, X.; Liao, W. *Org. Lett.* **2001**, *3*, 1499–1501. (j) Marchionni, C.; Vogel, P. *Helv. Chim. Acta* **2001**, *84*, 431–472. (k) Bode, J. W.; Fraefel, N.; Muri, D.; Carreira, E. M. *Angew. Chem., Int. Ed.* **2001**, *40*, 2082–2084.
- (l) Paterson, I.; Norcross, R. *Chem. Rev.* **1995**, *95*, 2041–2214.
- (a) Hoffman, R. W. *Angew. Chem., Int. Ed. Engl.* **1987**, *26*, 489–503. (b) Hoffman, R. W.; Dakmann, G.; Andersen, M. W. *Synthesis* **1994**, 629–638.
  - Cossy, J.; BouzBouz, S.; Pradaux, F.; Willis, C.; Bellosta, V. *Synlett* **2002**, 1595–1606 and references therein.
  - Collum, D. B.; Still, W. C.; Mohamadi, F. *J. Am. Chem. Soc.* **1986**, *108*, 2094–2096.
  - Barrett, A. G. M.; Tam, W. *J. Org. Chem.* **1997**, *62*, 4653–4664.
  - (a) Kocovsky, P.; Grech, J. M.; Mitchell, W. L. *J. Org. Chem.* **1995**, *60*, 1482–1483. (b) Kocovsky, P.; Grech, J. M.; Mitchell, W. L. *Tetrahedron Lett.* **1996**, *37*, 1125–1128. (c) Kocovsky, P.; Dunn, V.; Grech, J. M.; Srogl, J.; Mitchell, W. L. *Tetrahedron Lett.* **1996**, *37*, 5585–5588.
  - For some applications of the ring-opening of cyclopropanes with mercury(II) salts, see: (a) Collum, D. B.; Mohamadi, F.; Hallock, J. S. *J. Am. Chem. Soc.* **1983**, *105*, 6882–6889. (b) Landais, Y.; Parra-Rapado, L. *Tetrahedron Lett.* **1996**, *37*, 1209–1212. (c) Kocovsky, P.; Srogl, J.; Pour, M.; Gogoll, A. *J. Am. Chem. Soc.* **1994**, *116*, 186–197. (d) Kocovsky, P.; Srogl, J. *J. Org. Chem.* **1992**, *57*, 4565–4567. (e) Kocovsky, P.; Dunn, V.; Gogoll, A.; Langer, V. *J. Org. Chem.* **1999**, *64*, 101–119. (f) Mißlitz, U.; Primke, H.; de Meijere, A. *Chem. Ber.* **1989**, *122*, 537–543. (g) Lautens, M.; Tam, W.; Blackwell, J. *J. Am. Chem. Soc.* **1997**, *119*, 623–624. (h) Lautens, M.; Blackwell, J. *Synthesis* **1998**, 537–546. (i) Cossy, J.; Blanchard, N.; Defosseux, M.; Meyer, C. *Angew. Chem., Int. Ed.* **2002**, *41*, 2144–2146. (j) Defosseux, M.; Blanchard, N.; Meyer, C.; Cossy, J. *J. Org. Chem.* **2004**, *69*, 4626–4647.
  - For an account concerning the ring-opening of cyclopropylcarbinols with mercury(II) salts, see: Meyer, C.; Blanchard, N.; Defosseux, M.; Cossy, J. *Acc. Chem. Res.* **2003**, *36*, 766–772.
  - Cossy, J.; Blanchard, N.; Meyer, C. *Org. Lett.* **2001**, *3*, 2567–2569.
  - (a) Cossy, J.; Blanchard, N.; Hamel, C.; Meyer, C. *J. Org. Chem.* **1999**, *64*, 2608–2609. (b) Cossy, J.; Blanchard, N.; Meyer, C. *Synthesis* **1999**, 1063–1075. (c) Cossy, J.; Blanchard, N.; Meyer, C. *Eur. J. Org. Chem.* **2001**, 2841–2850.
  - Cossy, J.; Blanchard, N.; Meyer, C. *Tetrahedron Lett.* **1999**, *40*, 8361–8364.
  - (a) De Maré, G. R. *J. Mol. Struct. (Theochem)* **1987**, *153*, 341–356. (b) Plemenkov, V. V.; Butenko, O. J.; Zverev, V. V.; Ermolaeva, L. V.; Vakar, V. M.; Ignatchenko, A. V.; Bolesov, I. G. *J. Mol. Struct.* **1990**, *218*, 195–200.
  - (a) Arigoni, D.; Vasella, A.; Sharpless, K. B.; Jensen, H. P. *J. Am. Chem. Soc.* **1973**, *95*, 7917–7919. (b) Stephenson, L. M.; Speth, D. R. *J. Org. Chem.* **1979**, *44*, 4683–4689.
  - Lucbe, J.-L.; Rodriguez-Hahn, L.; Crabbé, P. *J. Chem. Soc., Chem. Commun.* **1978**, 601–602.
  - Ley, S. V.; Norman, J.; Griffith, W. P.; Marsden, S. P. *Synthesis* **1994**, 639–666.
  - Mengel, A.; Reiser, O. *Chem. Rev.* **1999**, *99*, 1191–1223.
  - (a) Still, W. C.; Barrish, J. *J. Am. Chem. Soc.* **1983**, *105*, 2487–2489. (b) Evans, D. A.; Fu, G. C.; Hoveyda, A. H. *J. Am. Chem. Soc.* **1988**, *110*, 6917–6918.
  - Corey, E. J.; Suggs, J. W. *Tetrahedron Lett.* **1975**, 2647–2650.
  - (a) Karabatsos, G. J.; Hsi, N. *J. Am. Chem. Soc.* **1965**, *87*, 2864–2870. (b) Pelissier, M.; Serafini, A.; Devanneaux, J.; Labarre, J.-F.; Tocanne, J.-F. *Tetrahedron* **1971**, *27*, 3271–3284. (c) Descotes, G.; Menet, A.; Collonges, F. *Tetrahedron* **1973**, *29*, 2931–2935. (d) Meyers, A. I.; Romine, J. L.; Fleming, S. A. *J. Am. Chem. Soc.* **1988**, *110*, 7245–7247. (e) Wong, H. N. C.; Hon, M.-Y.; Tse, C.-H.; Yip, Y.-C.; Tanko, J.; Hudlicky, T. *Chem. Rev.* **1989**, *89*, 165–198. (f) De Meiere, A. *Angew. Chem., Int. Ed. Engl.* **1979**, *18*, 809–826. (g) Lautens, M.; Delanghe, P. H. M. *J. Org. Chem.* **1995**, *60*, 2474–2487. (h) Ono, S.; Shuto, S.; Matsuda, A. *Tetrahedron Lett.* **1996**, *37*, 221–224. (i) Shuto, S.; Ono, S.; Hase, Y.; Kamiyama, N.; Takada, H.; Yamasihita, K.; Matsuda, A. *J. Org. Chem.* **1996**, *61*, 915–923.
  - (a) Whitesides, G. M.; San Filippo, J., Jr. *J. Am. Chem. Soc.* **1970**, *92*, 6611–6624. (b) Kang, S. H.; Lee, J. H.; Lee, S. B. *Tetrahedron Lett.* **1988**, *39*, 59–62 and references therein. (c) Evans, D. A.; Bender, S. L.; Morris, J. *J. Am. Chem. Soc.* **1988**, *110*, 2506–2526.
  - The structures of the minor organomercuric bromides **25''a** and **25'''c** were initially assigned to that of the epimers **25''a** and **25'''c**, which would have resulted from an oxymercuration occurring with retention of configuration at C3.<sup>10</sup> Although, **25''c** and **25'''c** would have both afforded **26'b** after reductive demercuration, it was clearly established by performing the reductive demercuration of the mixture of **25'a** and **25''a** on large scale that the stereotriad **26'a** was the single product generated. Moreover, the relative configuration of compound **26'b** was confirmed by a chemical correlation from the known stereotriad **33c**.



- Domon, L.; Vogeleisen, F.; Uguen, D. *Tetrahedron Lett.* **1996**, *37*, 2773–2776.
- Bicyclic orthoesters can be obtained by condensation of a 1,3,5-triol with an orthoester, see for example: Stork, G.; Rychnovsky, S. D. *J. Am. Chem. Soc.* **1987**, *109*, 1565–1567.
- (a) Nagaoka, H.; Kishi, Y. *Tetrahedron* **1981**, *23*, 3873–3888.

- (b) Gennari, C.; Colombo, L.; Bertolini, G.; Schimperna, G. *J. Org. Chem.* **1987**, 52, 2754–2760. (c) Yokoyama, Y.; Terada, Y.; Kawashima, H. *Bull. Chem. Soc. Jpn.* **1991**, 64, 2563–2565.
26. Rychnovsky, S. D.; Rogers, B. N.; Richardson, T. I. *Acc. Chem. Res.* **1998**, 31, 9–17.
27. Paterson, I.; Channon, J. A. *Tetrahedron Lett.* **1992**, 33, 797–800.
28. Hoffmann, R. W. *Chem. Rev.* **1989**, 89, 1841–1860.
29. Ohmori, Y.; Yamashita, A.; Tsujita, R.; Yamamoto, T.; Taniuchi, K.; Matsuda, A.; Shuto, S. *J. Med. Chem.* **2003**, 46, 5326–5333.

# Efficient lipase-catalyzed synthesis of new lipid antioxidants based on a catechol structure

A. Torres de Pinedo, P. Peñalver, D. Rondón and J. C. Morales\*

Department of Chemistry, Puleva Biotech, Camino de Purchil, 66, 18004 Granada, Spain

Received 10 March 2005; revised 30 May 2005; accepted 31 May 2005

Available online 17 June 2005

**Abstract**—Lipid antioxidants phenolic saturated fatty acid esters were synthesized in high yields and short reaction times using the corresponding ethyl fatty acid esters, lipase from *Candida Antarctica*, vacuum and no solvent. Phenolic esters with mono- and polyunsaturated fatty acids (EPA and DHA) were also prepared.

© 2005 Elsevier Ltd. All rights reserved.

## 1. Introduction

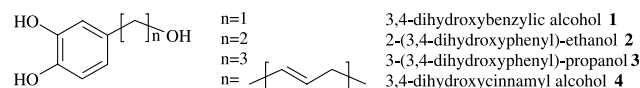
Oxygen is necessary for life of most biological systems. Paradoxically, the exposition to oxygen leads to oxidative stress by the formation of free radicals that react easily with other molecules in the cell, and may alter cellular mechanisms, being a possible cause of some inflammatory or cardiovascular diseases or even cancer and aging.<sup>1–3</sup> Similarly, oxidation affects deterioration of food, specially items with a high lipid fraction in their composition. Antioxidants are used by nature to counteract the effect of oxidation,<sup>4</sup> and new synthetic antioxidants are also been developed against the effects of oxidative stress.

Phenols are a large family of natural compounds that are able to donate the hydrogen atom of the phenolic OH to the free radicals, thus stopping the propagation chain during the oxidation process. Phenolic antioxidants have been studied due to their biological relevance. Hydroxytyrosol, a component of olive oil phenols, has been shown to inhibit human low-density lipoprotein (LDL) oxidation (a critical step in atherosclerosis),<sup>5,6</sup> to inhibit platelet aggregation<sup>7</sup> and to possess anti-inflammatory,<sup>8</sup> anticancer<sup>9</sup> and cell protection properties.<sup>10</sup> Lipid antioxidants have been prepared from natural antioxidants, since they would be able to prevent lipid peroxidation of cell membranes<sup>11,12</sup> and may also prevent oxidation of biologically important polyunsaturated fatty acids. Eicosapentaenoic acid (EPA) and docosahexaenoic acid (DHA) were covalently attached to ascorbic acid to protect them from oxidation.<sup>13</sup> Moreover,

most of the phenolic derivatives possess high solubility in aqueous solutions and it is very desirable for the food industry to be able to make them soluble in fats and oils.<sup>14</sup>

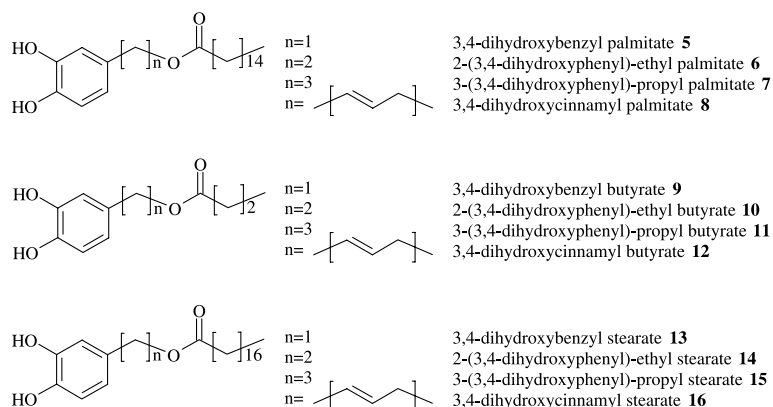
The use of lipases in non-aqueous solvents has been previously described for the preparation of phenolic acid esters. Guyot et al.<sup>15</sup> and Stamatis et al.<sup>16</sup> reported enzymatic esterification of phenolic acids and fatty alcohols with lipase CAL-B from *Candida Antarctica*, but in both cases very long reaction times were needed to obtain reasonable yields. Twu et al.<sup>17</sup> partially solved this problem for the esterification of hydroxyphenylpropionic acid and octanol, where high yields were obtained after 58 h. Buisman et al.<sup>18</sup> first investigated the esterification of phenols with carboxylic fatty acids and reported the synthesis of hydroxytyrosol with octanoic acid in hexane. They obtained acylation at the primary hydroxyl group of hydroxytyrosol with moderate yield after long reaction time. González-Alcudia et al.<sup>19</sup> reported the synthesis of hydroxytyrosol acetate in presence of pancreatic lipase in ethyl acetate after 48 h of reaction with 86% yield.

We present the enzymatic esterification of a series of di-*ortho*-phenolic compounds, including hydroxytyrosol, with several fatty acids using Novozym 435® (Fig. 1). High yields were obtained in short reaction times for all the phenolic esters prepared with saturated fatty acids by using no solvent and applying vacuum during the reaction (Fig. 2). Moderate to good yields were obtained for esters containing



**Figure 1.** Structures of phenol antioxidants under study.

**Keywords:** Lipid antioxidants; Phenols; Fatty acid ester; Hydroxytyrosol.  
\* Corresponding author. Tel.: +34 958 240320; fax: +34 958 240160;  
e-mail: jcmorales@pulevabiotech.es



**Figure 2.** Structures of phenolic saturated fatty acid esters synthesized.

monounsaturated and polyunsaturated fatty acids under the same reaction conditions (Fig. 3).

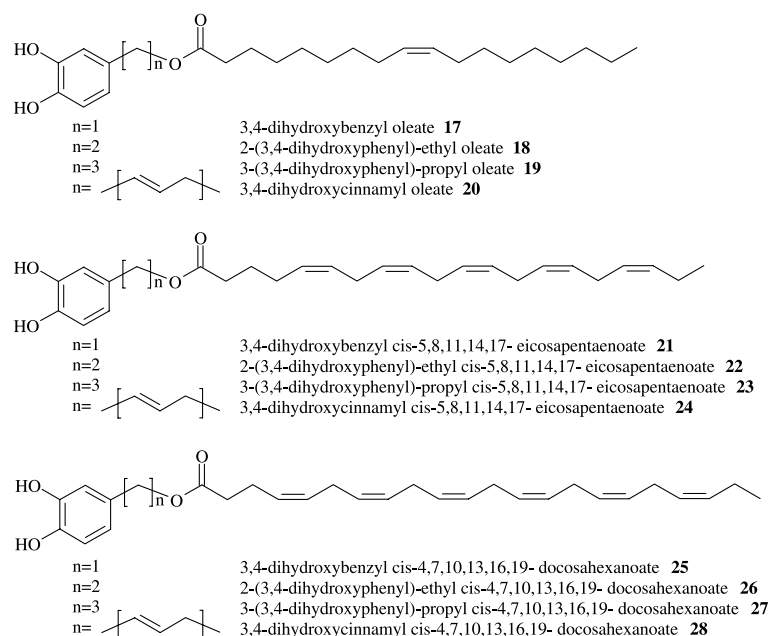
## 2. Results and discussion

We prepared the phenolic alcohols (1–4) by reduction from their corresponding carboxylic acids as reported by Capasso et al.<sup>20</sup> Acylation of these phenols was carried out with palmitic acid and lipase Novozym 435<sup>®</sup> following conditions reported by Buisman et al.<sup>18</sup> except that acetonitrile was used as solvent instead of hexane, due to solubility problems. We obtained the corresponding esters (5–8) in moderate yields (Table 1).

In order to improve the yields of the acylations obtained in acetonitrile, we tried ethyl esters as the acylating agents and also as the solvent. When 3,4-dihydroxybenzyl alcohol **1** was reacted with ethyl palmitate as the solvent using Novozym 435<sup>®</sup> at 37 °C, the reaction went almost to completion after 14 h and the corresponding ester was obtained with 98% yield after column purification. Work-up

of the reaction was quite simple. The reaction mixture was dissolved in acetonitrile, the lipase filtered, and the acetonitrile phase washed with hexane to eliminate excess of ethyl palmitate. Finally, it was concentrated and purified on a short silica column. When these new reaction conditions were extended to the other phenols in the series, high yields were obtained except for compound **8**, similarly to what happened under the previous reaction conditions (see Table 1).

Next, we extended the study to other saturated fatty acids to probe the influence of the length of the fatty acid in the esterification reaction using the conditions with ethyl fatty ester, no solvent and vacuum. We observed lower yields of ester formation for a short chain fatty acid, such as butyrate, than for palmitate, except for phenols **3** and **4**, where similar or better yields were obtained. High yields were obtained when ethyl stearate was used as the acylating agent in the reaction, similar to those for ethyl palmitate, except for compound **1**, possibly due to its low solubility in the reaction media. The effect of the length of the saturated carboxylic acid is not very clear. Actually, contradictory



**Figure 3.** Structures of phenolic unsaturated and polyunsaturated fatty acid esters synthesized.

**Table 1.** Reaction yields for phenolic saturated fatty acid esters

Phenol	Acylating agent	Product	Yield (%)
3,4-Dihydrobenzyl alcohol <b>1</b>	Palmitic acid <sup>a</sup>	<b>5</b>	75
2-(3,4-Dihydroxyphenyl)-ethanol <b>2</b>	Palmitic acid <sup>a</sup>	<b>6</b>	81
3-(3,4-Dihydroxyphenyl)-propanol <b>3</b>	Palmitic acid <sup>a</sup>	<b>7</b>	85
3,4-Dihydroxycinnamyl alcohol <b>4</b>	Palmitic acid <sup>a</sup>	<b>8</b>	69
3,4-Dihydrobenzyl alcohol <b>1</b>	Ethyl palmitate <sup>b</sup>	<b>5</b>	98
2-(3,4-Dihydroxyphenyl)-ethanol <b>2</b>	Ethyl palmitate <sup>b</sup>	<b>6</b>	98
3-(3,4-Dihydroxyphenyl)-propanol <b>3</b>	Ethyl palmitate <sup>b</sup>	<b>7</b>	97
3,4-Dihydroxycinnamyl alcohol <b>4</b>	Ethyl palmitate <sup>b</sup>	<b>8</b>	71
3,4-Dihydrobenzyl alcohol <b>1</b>	Ethyl butyrate <sup>b</sup>	<b>9</b>	75
2-(3,4-Dihydroxyphenyl)-ethanol <b>2</b>	Ethyl butyrate <sup>b</sup>	<b>10</b>	59
3-(3,4-Dihydroxyphenyl)-propanol <b>3</b>	Ethyl butyrate <sup>b</sup>	<b>11</b>	97
3,4-Dihydroxycinnamyl alcohol <b>4</b>	Ethyl butyrate <sup>b</sup>	<b>12</b>	96
3,4-Dihydrobenzyl alcohol <b>1</b>	Ethyl stearate <sup>b</sup>	<b>13</b>	74
2-(3,4-Dihydroxyphenyl)-ethanol <b>2</b>	Ethyl stearate <sup>b</sup>	<b>14</b>	94
3-(3,4-Dihydroxyphenyl)-propanol <b>3</b>	Ethyl stearate <sup>b</sup>	<b>15</b>	97
3,4-Dihydroxycinnamyl alcohol <b>4</b>	Ethyl stearate <sup>b</sup>	<b>16</b>	72

<sup>a</sup> Reaction conditions: phenol-fatty acid ratio, 1:2, Novozym 435<sup>®</sup>, acetonitrile, 37 °C, 16 h.

<sup>b</sup> Reaction conditions: phenol/ethyl fatty acid ester ratio, 1:30, Novozym 435<sup>®</sup>, no solvent, 37 °C, 6–16 h.

results are also found in the literature when *Candida Antarctica* lipase is used to esterify ascorbic acid with saturated fatty acids. Stamatis et al.<sup>16</sup> found a decrease in yields for ester formation with increasing chain length, whereas Yan et al.<sup>21</sup> found just the opposite effect. It is important to note that, in both cases, acetone or *tert*-butanol were used as the solvent and that long reaction times were needed to obtain reasonable yields.

Finally, we studied the phenolic ester formation with the ethyl esters of the biologically relevant oleic, eicosapentaenoic (EPA), and docosahexaenoic (DHA) acids. Lower yields were obtained for oleic than for stearic ethyl ester for all four phenolic compounds in the series, except for compound **4** that maintained the same yields for both (see Table 2). A more dramatic decrease in yields (29–51%) was obtained for EPA and DHA ethyl esters when reacted with phenols **1**, **2**, and **4**. Actually, the side reaction of hydrolysis of the corresponding fatty acid ethyl esters to the carboxylic acid was quite fast in these cases as observed by TLC. Surprisingly, reaction with compound **3** resulted in 67 and 97% of the ester formation with DHA and EPA, respectively. Probably, the fact that the primary alcohol is at three-carbon distance from the phenolic structure in compound **3** helps the ester reaction to compete with the hydrolysis reaction of the polyunsaturated ethyl esters.

### 3. Experimental

Chemicals were purchased from Sigma-Aldrich and used without further purification. The immobilized lipase from *Candida Antarctica* (Novozym 435<sup>®</sup>) was a gift from Novozymes A/S Spain. Thin-layer chromatography (TLC) was performed on precoated silica gel 60 Alugram SIL/UV<sub>254</sub> from Macherey Nagel. FAB Mass spectra were collected on a Hewlett-Packard 5988 spectrometer, using a Fisons VG platform or a Fisons VG Autospec-Q. NMR experiments were performed on a Bruker AM-300 and a Bruker AMX-300, operating at 300 MHz for <sup>1</sup>H and 75 MHz for <sup>13</sup>C, and on a Bruker AMX-400, operating at 400 MHz for <sup>1</sup>H and 100 MHz for <sup>13</sup>C. CDCl<sub>3</sub> was used as solvent. Chemical shifts are expressed in  $\delta$  (parts per million) using the solvent as internal reference.

#### 3.1. Synthetic procedure

A suspension of the alcohol (0.4 mmol), Novozym 435<sup>®</sup> (40 mg) in ethyl fatty acid ester (12 mmol) was stirred vigorously under vacuum (5–10 mmHg) at 37 °C for 4–16 h. Then, acetonitrile (75 mL) was added, lipase filtered, and the crude washed with hexane (3 × 25 mL). The acetonitrile phase was concentrated to dryness under reduced pressure and finally purified in a short silica column using flash chromatography (hexane/diethyl ether 10:1, 2:1

**Table 2.** Reaction yields for phenolic mono- and polyunsaturated fatty acid esters

Phenol	Acylating agent	Product	Yield (%)
3,4-Dihydrobenzyl alcohol <b>1</b>	Ethyl oleate	<b>17</b>	64
2-(3,4-Dihydroxyphenyl)-ethanol <b>2</b>	Ethyl oleate	<b>18</b>	81
3-(3,4-Dihydroxyphenyl)-propanol <b>3</b>	Ethyl oleate	<b>19</b>	87
3,4-Dihydroxycinnamyl alcohol <b>4</b>	Ethyl oleate	<b>20</b>	72
3,4-Dihydrobenzyl alcohol <b>1</b>	Ethyl eicosapentaenoate	<b>21</b>	33
2-(3,4-Dihydroxyphenyl)-ethanol <b>2</b>	Ethyl eicosapentaenoate	<b>22</b>	51
3-(3,4-Dihydroxyphenyl)-propanol <b>3</b>	Ethyl eicosapentaenoate	<b>23</b>	97
3,4-Dihydroxycinnamyl alcohol <b>4</b>	Ethyl eicosapentaenoate	<b>24</b>	32
3,4-Dihydrobenzyl alcohol <b>1</b>	Ethyl docosahexaenoate	<b>25</b>	32
2-(3,4-Dihydroxyphenyl)-ethanol <b>2</b>	Ethyl docosahexaenoate	<b>26</b>	43
3-(3,4-Dihydroxyphenyl)-propanol <b>3</b>	Ethyl docosahexaenoate	<b>27</b>	67
3,4-Dihydroxycinnamyl alcohol <b>4</b>	Ethyl docosahexaenoate	<b>28</b>	29

Reaction conditions: phenol-carboxylic ethyl ester ratio, 1:30, Novozym 435<sup>®</sup>, no solvent, 37 °C, 4–16 h.

or 1:1 depending on the polarity of final compound) to yield the phenolic fatty acid ester. In the case of the reactions with butyrate ethyl ester, no final chromatography was needed. All compounds were >95% pure as observed by  $^1\text{H}$  NMR spectroscopy.

### 3.2. HPLC procedure

Monitoring by HPLC was carried out using 2695 Alliance Waters separation system and a 2996 photodiode array detector. The column was a Symmetry C18, 250×4.0 mm, 5  $\mu\text{m}$  particle size, protected with a C18 precolumn. The mobile phase A was acetonitrile and B was 1% acetic acid in water. Gradient started on 92% A for 4 min, then linear ramp to 100% A in 6 more min, maintaining 100% A for 8 min, and returning to starting conditions in 2 min. Flow rate was 1 mL/min and detection was achieved at 280 nm.

**3.2.1. 3,4-Dihydroxybenzylic palmitate 5.** 98%. White solid;  $^1\text{H}$  NMR (300 MHz,  $\text{CDCl}_3$ ):  $\delta$  6.89 (d,  $J=1.5$  Hz, 1H, ar), 6.84 (d,  $J=8.1$  Hz, 1H, ar), 6.79 (dd,  $J=8.0$ , 1.7 Hz, 1H, ar), 4.99 (s, 2H,  $\text{PhCH}_2\text{OOC}$ –), 2.32 (t,  $J=7.4$  Hz, 2H,  $-\text{OOC}-\text{CH}_2-$ ), 1.61 (q,  $J=6.0$  Hz, 2H,  $\text{OOC}-\text{CH}_2-\text{CH}_2$ ), 1.25 (m, 24H,  $-\text{CH}_2-$ ), 0.87 (t,  $J=6.4$  Hz, 3H,  $-\text{CH}_3$ );  $^{13}\text{C}$  NMR (75 MHz,  $\text{CDCl}_3$ ):  $\delta$  175.7 ( $-\text{COO}$ –), 145.2, 144.9, 130.3, 122.9, 117.2, 116.7 (Ar), 67.5 ( $\text{PhCH}_2\text{OCO}$ –), 35.9 ( $-\text{OOC}-\text{CH}_2-$ ), 33.3, 31.1, 31.0, 30.8, 30.7, 30.6, 30.5, 26.3, 24.1 ( $-\text{CH}_2-$ ), 15.5 ( $-\text{CH}_3$ ); HRMS FAB+ calcd 401.2668 for  $\text{C}_{23}\text{H}_{38}\text{O}_4\text{Na}$  [ $\text{M}+\text{Na}$ ] $^+$ , found 401.2672.

**3.2.2. 2-(3,4-Dihydroxyphenyl) ethyl palmitate 6.** 98%. White solid;  $^1\text{H}$  NMR (300 MHz,  $\text{CDCl}_3$ ):  $\delta$  6.78 (d,  $J=8.1$  Hz, 1H, ar), 6.73 (d,  $J=1.5$  Hz, 1H, ar), 6.63 (dd,  $J=8.0$ , 1.5 Hz, 1H, ar), 4.23 (t,  $J=7.1$  Hz, 2H,  $-\text{CH}_2\text{OOC}$ –), 2.80 (t,  $J=7.1$  Hz, 2H, ar- $\text{CH}_2-$ ), 2.28 (t,  $J=7.5$  Hz, 2H,  $-\text{OOC}-\text{CH}_2-$ ), 1.58 (q,  $J=6.1$  Hz, 2H,  $-\text{OOC}-\text{CH}_2-\text{CH}_2$ ), 1.25 (m, 24H,  $-\text{CH}_2-$ ), 0.87 (t,  $J=6.4$  Hz, 3H,  $-\text{CH}_3$ );  $^{13}\text{C}$  NMR (75 MHz,  $\text{CDCl}_3$ ):  $\delta$  174.5 ( $-\text{COO}$ –), 143.7, 142.4, 130.7, 121.4, 116.0, 115.5 (Ar), 65.1 ( $-\text{CH}_2\text{OCO}$ –), 34.6, 34.5, 32.0, 29.8, 29.7, 29.7, 29.5, 29.4, 29.3, 29.2, 25.0, 24.8, 22.8 ( $-\text{CH}_2-$ ), 14.2 ( $-\text{CH}_3$ ); HRMS FAB+ calcd 415.2824 for  $\text{C}_{24}\text{H}_{40}\text{O}_4\text{Na}$  [ $\text{M}+\text{Na}$ ] $^+$ , found 415.2819.

**3.2.3. 3-(3,4-Dihydroxyphenyl) propyl palmitate 7.** 97%. White solid;  $^1\text{H}$  NMR (300 MHz,  $\text{CDCl}_3$ ):  $\delta$  6.76 (d,  $J=8.0$  Hz, 1H, ar), 6.68 (d,  $J=1.8$  Hz, 1H, ar), 6.58 (dd,  $J=8.0$ , 1.8 Hz, 1H, ar), 4.06 (t,  $J=6.6$  Hz, 2H,  $-\text{CH}_2\text{OOC}$ –), 2.55 (t,  $J=7.4$  Hz, 2H, ar- $\text{CH}_2-$ ), 2.30 (t,  $J=7.5$  Hz, 2H,  $-\text{OOC}-\text{CH}_2-$ ), 1.88 (q,  $J=6.7$  Hz, 2H,  $-\text{CH}_2-$ ), 1.65 (q,  $J=7.2$  Hz, 2H,  $-\text{OOC}-\text{CH}_2-\text{CH}_2$ ), 1.24;  $^{13}\text{C}$  NMR (75 MHz,  $\text{CDCl}_3$ ):  $\delta$  174.5 ( $-\text{COO}$ –), 143.7, 141.8, 134.3, 120.8, 115.6, 115.5 (Ar), 63.8 ( $-\text{CH}_2\text{OCO}$ –), 34.5, 32.0, 31.5, 30.4, 29.8, 29.7, 29.6, 29.5, 29.4, 29.3, 29.2, 25.1, 22.8 ( $-\text{CH}_2-$ ), 14.2 ( $-\text{CH}_3$ ); HRMS FAB+ calcd 429.2981 for  $\text{C}_{25}\text{H}_{42}\text{O}_4\text{Na}$  [ $\text{M}+\text{Na}$ ] $^+$ , found 429.2977.

**3.2.4. 3,4-Dihydroxycinnamyl palmitate 8.** 71%. White solid;  $^1\text{H}$  NMR (300 MHz,  $\text{CDCl}_3$ ):  $\delta$  6.92 (s, 1H, ar), 6.81 (s, 2H, ar), 6.51 (d,  $J=15.8$  Hz, 1H,  $\text{Ph}-\text{CH}=\text{CH}-\text{CH}_2-$ ), 6.09 (dt,  $J=15.8$ , 6.6 Hz, 1H,  $\text{Ph}-\text{CH}=\text{CH}-\text{CH}_2-$ ), 4.69 (d,  $J=6.5$  Hz,  $\text{Ph}-\text{CH}=\text{CH}-\text{CH}_2-$ ), 2.33 (t,  $J=7.4$  Hz, 2H,  $-\text{OOC}-\text{CH}_2-$ ), 1.63 (q,  $J=7.0$  Hz, 2H,  $-\text{OOC}-\text{CH}_2-\text{CH}_2$ ),

1.25 (m, 24H,  $-\text{CH}_2-$ ), 0.87 (t,  $J=6.3$  Hz, 3H,  $-\text{CH}_3$ );  $^{13}\text{C}$  NMR (75 MHz,  $\text{CDCl}_3$ ):  $\delta$  174.2 ( $-\text{COO}$ –), 134.0 ( $\text{Ph}-\text{CH}=\text{CH}$ –), 121.3 ( $\text{Ph}-\text{CH}=\text{CH}$ –), 143.9, 143.8, 129.9, 120.2, 115.5, 113.3 (Ar), 65.2 ( $-\text{CH}_2\text{OCO}$ –), 34.4, 32.0, 30.4, 29.8, 29.7, 29.5, 29.4, 29.3, 29.2, 25.1, 22.8 ( $-\text{CH}_2-$ ), 14.2 ( $-\text{CH}_3$ ); HRMS FAB+ calcd 427.2824 for  $\text{C}_{25}\text{H}_{40}\text{O}_4\text{Na}$  [ $\text{M}+\text{Na}$ ] $^+$ , found 427.2819.

**3.2.5. 3,4-Dihydroxybenzylic butyrate 9.** 75%. Transparent syrup;  $^1\text{H}$  NMR (300 MHz,  $\text{CDCl}_3$ ):  $\delta$  6.88 (d,  $J=1.8$  Hz, 1H, ar), 6.83 (d,  $J=8.0$  Hz, 1H, ar), 6.79 (dd,  $J=8.0$ , 1.7 Hz, 1H, ar), 4.99 (s, 2H,  $\text{PhCH}_2\text{OOC}$ –), 2.31 (t,  $J=7.4$  Hz, 2H,  $-\text{OOC}-\text{CH}_2-$ ), 1.65 (h,  $J=7.4$  Hz, 2H,  $\text{OOC}-\text{CH}_2-\text{CH}_2$ ), 0.92 (t,  $J=7.4$  Hz, 3H,  $-\text{CH}_3$ );  $^{13}\text{C}$  NMR (75 MHz,  $\text{CDCl}_3$ ):  $\delta$  174.5 ( $-\text{COO}$ –), 144.0, 143.7, 128.9, 121.5, 115.9, 115.4 (Ar), 66.3 ( $\text{PhCH}_2\text{OCO}$ –), 36.4 ( $-\text{OOC}-\text{CH}_2-$ ), 18.5 ( $-\text{OOC}-\text{CH}_2-\text{CH}_2$ ), 13.7 ( $-\text{CH}_3$ ); HRMS FAB+ calcd 222.0892 for  $\text{C}_{12}\text{H}_{14}\text{O}_4\text{Na}$  [ $\text{M}+\text{Na}$ ] $^+$ , found 222.0892.

**3.2.6. 2-(3,4-Dihydroxyphenyl) ethyl butyrate 10.** 59%. Transparent syrup;  $^1\text{H}$  NMR (300 MHz,  $\text{CDCl}_3$ ):  $\delta$  6.78 (d,  $J=8.1$  Hz, 1H, ar), 6.73 (d,  $J=1.5$  Hz, 1H, ar), 6.63 (dd,  $J=8.0$ , 1.5 Hz, 1H, ar), 6.19 (1s (w), 1H,  $\text{Ph}-\text{OH}$ ), 6.0 (1s (w), 1H,  $\text{Ph}-\text{OH}$ ), 4.23 (t,  $J=7.1$  Hz, 2H,  $-\text{CH}_2\text{OOC}$ –), 2.79 (t,  $J=7.1$  Hz, 2H,  $\text{Ph}-\text{CH}_2-$ ), 2.27 (t,  $J=7.5$  Hz, 2H,  $-\text{OOC}-\text{CH}_2-$ ), 1.65 (h,  $J=7.4$  Hz, 2H,  $-\text{OOC}-\text{CH}_2-\text{CH}_2$ ), 0.92 (t,  $J=7.4$  Hz, 3H,  $-\text{CH}_3$ );  $^{13}\text{C}$  NMR (75 MHz,  $\text{CDCl}_3$ ):  $\delta$  174.9 ( $-\text{COO}$ –), 143.9, 142.6, 130.5, 121.3, 115.9, 115.5 (Ar), 65.3 ( $-\text{CH}_2\text{OCO}$ –), 36.4 ( $-\text{OOC}-\text{CH}_2-$ ), 34.5 ( $\text{Ph}-\text{CH}_2-$ ), 18.5 ( $-\text{OOC}-\text{CH}_2-\text{CH}_2$ ), 13.7 ( $-\text{CH}_3$ ); HRMS FAB+ calcd 247.0946 for  $\text{C}_{12}\text{H}_{16}\text{O}_4\text{Na}$  [ $\text{M}+\text{Na}$ ] $^+$ , found 247.0947.

**3.2.7. 3-(3,4-Dihydroxyphenyl) propyl butyrate 11.** 97%. Transparent syrup;  $^1\text{H}$  NMR (300 MHz,  $\text{CDCl}_3$ ):  $\delta$  6.77 (d,  $J=8.0$  Hz, 1H, ar), 6.68 (d,  $J=1.5$  Hz, 1H, ar), 6.58 (dd,  $J=8.0$ , 1.6 Hz, 1H, ar), 4.07 (t,  $J=6.6$  Hz, 2H,  $-\text{CH}_2\text{OOC}$ –), 2.55 (t,  $J=7.4$  Hz, 2H, ar- $\text{CH}_2-$ ), 2.30 (t,  $J=7.5$  Hz, 2H,  $-\text{OOC}-\text{CH}_2-$ ), 1.89 (q,  $J=6.7$  Hz, 2H,  $-\text{CH}_2-$ ), 1.65 (h,  $J=7.5$  Hz, 2H,  $-\text{OOC}-\text{CH}_2-\text{CH}_2$ ), 0.95 (t,  $J=7.4$  Hz, 3H,  $-\text{CH}_3$ );  $^{13}\text{C}$  NMR (75 MHz,  $\text{CDCl}_3$ ):  $\delta$  174.6 ( $-\text{COO}$ –), 143.8, 141.9, 134.2, 120.8, 115.6, 115.4 (Ar), 63.9 ( $-\text{CH}_2\text{OCO}$ –), 36.4 ( $-\text{OOC}-\text{CH}_2-$ ), 31.5, 30.3, 18.6 ( $-\text{CH}_2-$ ), 13.7 ( $-\text{CH}_3$ ); HRMS FAB+ calcd 261.1103 for  $\text{C}_{13}\text{H}_{18}\text{O}_4\text{Na}$  [ $\text{M}+\text{Na}$ ] $^+$ , found 261.1107.

**3.2.8. 3,4-Dihydroxycinnamyl butyrate 12.** 96%. Transparent syrup;  $^1\text{H}$  NMR (300 MHz,  $\text{CDCl}_3$ ):  $\delta$  6.92 (s, 1H, ar), 6.80 (s, 2H, ar), 6.51 (d,  $J=15.8$  Hz, 1H,  $\text{Ph}-\text{CH}=\text{CH}-\text{CH}_2-$ ), 6.09 (dt,  $J=15.8$ , 6.6 Hz, 1H,  $\text{Ph}-\text{CH}=\text{CH}-\text{CH}_2-$ ), 4.69 (d,  $J=6.5$  Hz,  $\text{Ph}-\text{CH}=\text{CH}-\text{CH}_2-$ ), 2.32 (t,  $J=7.4$  Hz, 2H,  $-\text{OOC}-\text{CH}_2-$ ), 1.66 (h,  $J=7.4$  Hz, 2H,  $-\text{OOC}-\text{CH}_2-\text{CH}_2$ ), 0.95 (t,  $J=7.4$  Hz, 3H,  $-\text{CH}_3$ );  $^{13}\text{C}$  NMR (75 MHz,  $\text{CDCl}_3$ ):  $\delta$  174.1 ( $-\text{COO}$ –), 134.1 ( $\text{Ph}-\text{CH}=\text{CH}$ –), 121.4 ( $\text{Ph}-\text{CH}=\text{CH}$ –), 144.0, 143.8, 129.8, 120.2, 115.5, 113.3 (Ar), 65.3 ( $-\text{CH}_2\text{OCO}$ –), 36.4 ( $-\text{OOC}-\text{CH}_2-$ ), 18.6 ( $-\text{CH}_2-$ ), 13.7 ( $-\text{CH}_3$ ); HRMS FAB+ calcd 259.1105 for  $\text{C}_{13}\text{H}_{16}\text{O}_4\text{Na}$  [ $\text{M}+\text{Na}$ ] $^+$ , found 259.1109.

**3.2.9. 3,4-Dihydroxybenzylic stearate 13.** 74%. White solid;  $^1\text{H}$  NMR (300 MHz,  $\text{CDCl}_3$ ):  $\delta$  6.88 (d,  $J=1.8$  Hz, 1H, ar), 6.83 (d,  $J=8.1$  Hz, 1H, ar), 6.78 (dd,  $J=8.0$ ,



1.7 Hz, 1H, ar), 4.99 (s, 2H, PhCH<sub>2</sub>OOC–), 2.33 (t, *J* = 7.7 Hz, 2H, –OOC–CH<sub>2</sub>–), 1.61 (q, *J* = 7.2 Hz, 2H, OOC–CH<sub>2</sub>–CH<sub>2</sub>–), 1.25 (m, 28H, –CH<sub>2</sub>–), 0.87 (t, *J* = 6.4 Hz, 3H, –CH<sub>3</sub>); <sup>13</sup>C NMR (75 MHz, CDCl<sub>3</sub>): δ 174.7 (–COO–), 144.1, 143.7, 128.8, 121.5, 115.8, 115.3 (Ar), 66.3 (PhCH<sub>2</sub>OOC–), 34.6 (–OOC–CH<sub>2</sub>–), 31.9, 29.7, 29.7, 29.6, 29.5, 29.4, 29.3, 29.2, 25.0, 22.7 (–CH<sub>2</sub>–), 14.1 (–CH<sub>3</sub>); HRMS FAB+ calcd 429.2981 for C<sub>25</sub>H<sub>42</sub>O<sub>4</sub>Na [M+Na]<sup>+</sup>, found 429.2987.

**3.2.10. 2-(3,4-Dihydroxyphenyl) ethyl stearate 14.** 94%. White solid; <sup>1</sup>H NMR (300 MHz, CDCl<sub>3</sub>): δ 6.79 (d, *J* = 8.1 Hz, 1H, ar), 6.72 (d, *J* = 2.0 Hz, 1H, ar), 6.63 (dd, *J* = 8.0, 2.0 Hz, 1H, ar), 4.23 (t, *J* = 7.1 Hz, 2H, –CH<sub>2</sub>OOC–), 2.80 (t, *J* = 7.1 Hz, 2H, ar-CH<sub>2</sub>–), 2.28 (t, *J* = 7.4 Hz, 2H, –OOC–CH<sub>2</sub>–), 1.58 (m, 2H, –OOC–CH<sub>2</sub>–CH<sub>2</sub>–), 1.24 (m, 28H, –CH<sub>2</sub>–), 0.87 (t, *J* = 6.9 Hz, 3H, –CH<sub>3</sub>); <sup>13</sup>C NMR (75 MHz, CDCl<sub>3</sub>): δ 174.6 (–COO–), 143.8, 142.5, 130.6, 121.4, 116.0, 115.4 (Ar), 65.1 (–CH<sub>2</sub>OOC–), 34.6, 34.5, 31.9, 29.7, 29.7, 29.6, 29.5, 29.4, 29.3, 29.2, 25.0, 24.8, 22.7 (–CH<sub>2</sub>–), 14.2 (–CH<sub>3</sub>); HRMS FAB+ calcd 443.3137 for C<sub>26</sub>H<sub>44</sub>O<sub>4</sub>Na [M+Na]<sup>+</sup>, found 443.3141.

**3.2.11. 3-(3,4-Dihydroxyphenyl) propyl stearate 15.** 97%. White solid; <sup>1</sup>H NMR (300 MHz, CDCl<sub>3</sub>): δ 6.76 (d, *J* = 8.1 Hz, 1H, ar), 6.69 (d, *J* = 1.9 Hz, 1H, ar), 6.59 (dd, *J* = 8.1, 2.0 Hz, 1H, ar), 4.07 (t, *J* = 6.6 Hz, 2H, –CH<sub>2</sub>OOC–), 2.56 (t, *J* = 7.6 Hz, 2H, ar-CH<sub>2</sub>–), 2.30 (t, *J* = 7.4 Hz, 2H, –OOC–CH<sub>2</sub>–), 1.89 (q, *J* = 6.8 Hz, 2H, –CH<sub>2</sub>–), 1.61 (q, *J* = 7.0 Hz, 2H, –OOC–CH<sub>2</sub>–CH<sub>2</sub>–), 1.27 (m, 28H, –CH<sub>2</sub>–), 0.87 (t, *J* = 6.9 Hz, 3H, –CH<sub>3</sub>); <sup>13</sup>C NMR (75 MHz, CDCl<sub>3</sub>): δ 174.4 (–COO–), 143.7, 141.8, 134.3, 120.8, 115.5, 115.4 (Ar), 63.7 (–CH<sub>2</sub>OOC–), 34.5, 31.9, 31.5, 30.3, 29.7, 29.7, 29.5, 29.4, 29.3, 29.2, 29.1, 25.1, 22.7 (–CH<sub>2</sub>–), 14.1 (–CH<sub>3</sub>); HRMS FAB+ calcd 457.3294 for C<sub>27</sub>H<sub>46</sub>O<sub>4</sub>Na [M+Na]<sup>+</sup>, found 457.3301.

**3.2.12. 3,4-Dihydroxycinnamyl stearate 16.** 72%. White solid; <sup>1</sup>H NMR (300 MHz, CDCl<sub>3</sub>): δ 6.93 (s, 1H, ar), 6.81 (s, 2H, ar), 6.51 (d, *J* = 15.8 Hz, 1H, Ph-CH=CH–CH<sub>2</sub>–), 6.09 (dt, *J* = 15.8, 6.6 Hz, 1H, Ph-CH=CH–CH<sub>2</sub>–), 4.69 (d, *J* = 6.5 Hz, Ph-CH=CH–CH<sub>2</sub>–), 2.33 (t, *J* = 7.5 Hz, 2H, –OOC–CH<sub>2</sub>–), 1.63 (q, *J* = 7.1 Hz, 2H, –OOC–CH<sub>2</sub>–CH<sub>2</sub>–), 1.24 (m, 28H, –CH<sub>2</sub>–), 0.87 (t, *J* = 6.4 Hz, 3H, –CH<sub>3</sub>); <sup>13</sup>C NMR (75 MHz, CDCl<sub>3</sub>): δ 174.2 (–COO–), 134.0 (Ph-CH=CH–), 121.3 (Ph-CH=CH–), 143.9, 143.7, 129.9, 120.3, 115.5, 113.3 (Ar), 65.2 (–CH<sub>2</sub>OOC–), 34.5, 32.0, 29.8, 29.7, 29.6, 29.4, 29.3, 29.2, 25.1, 22.8 (–CH<sub>2</sub>–), 14.2 (–CH<sub>3</sub>); HRMS FAB+ calcd 455.3137 for C<sub>27</sub>H<sub>44</sub>O<sub>4</sub>Na [M+Na]<sup>+</sup>, found 455.3136.

**3.2.13. 3,4-Dihydroxybenzyl oleate 17.** 63%. Light yellow syrup; <sup>1</sup>H NMR (300 MHz, CDCl<sub>3</sub>): δ 6.88 (s, 1H, ar), 6.83 (d, AB system, *J* = 8.0 Hz, 1H, ar), 6.79 (d, AB system, *J* = 8.4, 1.7 Hz, 1H, ar), 5.34 (m, 2H, HC=CH), 4.99 (s, 2H, PhCH<sub>2</sub>OOC–), 2.32 (t, *J* = 7.5 Hz, 2H, –OOC–CH<sub>2</sub>–), 1.99 (m, 4H, –CH<sub>2</sub>–HC=CH–CH<sub>2</sub>–), 1.61 (q, *J* = 6.8 Hz, 2H, –OOC–CH<sub>2</sub>–CH<sub>2</sub>–), 1.26 (m, 26H, –CH<sub>2</sub>–), 0.87 (t, *J* = 6.7 Hz, 3H, –CH<sub>3</sub>); <sup>13</sup>C NMR (75 MHz, CDCl<sub>3</sub>): δ 174.4 (–COO–), 130.1, 129.8 (–HC=CH–), 143.9, 143.7, 129.0, 121.6, 115.9, 115.4 (Ar), 66.2 (PhCH<sub>2</sub>OOC–), 34.5, 31.9, 29.8, 29.7, 29.6, 29.4, 29.2, 29.1, 27.3, 27.2, 25.0, 22.7 (–CH<sub>2</sub>–HC=CH–CH<sub>2</sub>–, –CH<sub>2</sub>–), 14.2 (–CH<sub>3</sub>); HRMS

FAB+ calcd 427.2824 for C<sub>25</sub>H<sub>40</sub>O<sub>4</sub>Na [M+Na]<sup>+</sup>, found 427.2822.

**3.2.14. 2-(3,4-Dihydroxyphenyl) ethyl oleate 18.** 93%. Light yellow syrup; <sup>1</sup>H NMR (300 MHz, CDCl<sub>3</sub>): δ 6.78 (d, *J* = 8.1 Hz, 1H, ar), 6.72 (d, *J* = 2.0 Hz, 1H, ar), 6.63 (dd, *J* = 8.0, 2.0 Hz, 1H, ar), 5.34 (m, 2H, HC=CH), 4.23 (t, *J* = 7.1 Hz, 2H, –CH<sub>2</sub>OOC–), 2.80 (t, *J* = 7.1 Hz, 2H, ar-CH<sub>2</sub>–), 2.28 (t, *J* = 7.6 Hz, 2H, –OOC–CH<sub>2</sub>–), 1.99 (m, 4H, –CH<sub>2</sub>–HC=CH–CH<sub>2</sub>–), 1.58 (m, 2H, –OOC–CH<sub>2</sub>–CH<sub>2</sub>–), 1.26 (m, 20H, –CH<sub>2</sub>–), 0.87 (t, *J* = 6.9 Hz, 3H, –CH<sub>3</sub>); <sup>13</sup>C NMR (75 MHz, CDCl<sub>3</sub>): δ 174.8 (–COO–), 130.1, 129.8 (–HC=CH–), 143.8, 142.5, 130.5, 121.3, 115.9, 115.4 (Ar), 65.3 (–CH<sub>2</sub>OOC–), 34.5, 31.9, 31.3, 29.7, 29.6, 29.4, 29.2, 29.1, 27.3, 27.2, 25.0, 22.7 (–CH<sub>2</sub>–HC=CH–CH<sub>2</sub>–, –CH<sub>2</sub>–), 14.2 (–CH<sub>3</sub>); HRMS FAB+ calcd 441.2981 for C<sub>26</sub>H<sub>42</sub>O<sub>4</sub>Na [M+Na]<sup>+</sup>, found 441.2979.

**3.2.15. 3-(3,4-Dihydroxyphenyl) propyl oleate 19.** 87%. Light yellow syrup; <sup>1</sup>H NMR (300 MHz, CDCl<sub>3</sub>): δ 6.76 (d, *J* = 8.1 Hz, 1H, ar), 6.69 (d, *J* = 2.0 Hz, 1H, ar), 6.58 (dd, *J* = 8.0, 2.0 Hz, 1H, ar), 5.33 (m, 2H, HC=CH), 4.07 (t, *J* = 6.6 Hz, 2H, –CH<sub>2</sub>OOC–), 2.55 (t, *J* = 7.3 Hz, 2H, ar-CH<sub>2</sub>–), 2.30 (t, *J* = 7.4 Hz, 2H, –OOC–CH<sub>2</sub>–), 1.99 (m, 4H, –CH<sub>2</sub>–HC=CH–CH<sub>2</sub>–), 1.89 (q, *J* = 6.8 Hz, 2H, –CH<sub>2</sub>–), 1.61 (m, 2H, –OOC–CH<sub>2</sub>–CH<sub>2</sub>–), 1.26 (m, 20H, –CH<sub>2</sub>–), 0.87 (t, *J* = 6.9 Hz, 3H, –CH<sub>3</sub>); <sup>13</sup>C NMR (75 MHz, CDCl<sub>3</sub>): δ 174.6 (–COO–), 130.1, 129.8 (–HC=CH–), 143.7, 141.9, 134.2, 120.7, 115.5, 115.4 (Ar), 63.8 (–CH<sub>2</sub>OOC–), 34.5, 31.9, 31.4, 30.3, 29.8, 29.7, 29.6, 29.4, 29.2, 29.1, 27.3, 27.2, 25.0, 22.7 (–CH<sub>2</sub>–HC=CH–CH<sub>2</sub>–, –CH<sub>2</sub>–), 14.1 (–CH<sub>3</sub>); HRMS FAB+ calcd 455.3137 for C<sub>27</sub>H<sub>44</sub>O<sub>4</sub>Na [M+Na]<sup>+</sup>, found 455.3138.

**3.2.16. 3,4-Dihydroxycinnamyl oleate 20.** 72%. Light yellow syrup; <sup>1</sup>H NMR (300 MHz, CDCl<sub>3</sub>): δ 6.93 (s, 1H, ar), 6.81 (s, 2H, ar), 6.51 (d, *J* = 15.8 Hz, 1H, Ph-CH=CH–CH<sub>2</sub>–), 6.08 (dt, *J* = 15.8, 6.6 Hz, 1H, Ph-CH=CH–CH<sub>2</sub>–), 5.34 (m, 2H, HC=CH), 4.69 (d, *J* = 6.6 Hz, Ph-CH=CH–CH<sub>2</sub>–), 2.33 (t, *J* = 7.5 Hz, 2H, –OOC–CH<sub>2</sub>–), 2.0 (m, 4H, –CH<sub>2</sub>–HC=CH–CH<sub>2</sub>–), 1.63 (q, *J* = 7.1 Hz, 2H, –OOC–CH<sub>2</sub>–CH<sub>2</sub>–), 1.26 (m, 26H, –CH<sub>2</sub>–), 0.87 (t, *J* = 7.0 Hz, 3H, –CH<sub>3</sub>); <sup>13</sup>C NMR (75 MHz, CDCl<sub>3</sub>): δ 174.2 (–COO–), 130.1, 129.8 (–HC=CH–), 134.1 (Ph-CH=CH–), 121.2 (Ph-CH=CH–), 144.0, 143.8, 129.7, 120.1, 115.4, 113.2 (Ar), 65.3 (–CH<sub>2</sub>OOC–), 34.5, 33.9, 31.9, 29.8, 29.7, 29.6, 29.3, 29.2, 29.1, 27.3, 27.2, 25.0, 24.7, 22.7 (–CH<sub>2</sub>–HC=CH–CH<sub>2</sub>–, –CH<sub>2</sub>–), 14.1 (–CH<sub>3</sub>); HRMS FAB+ calcd 430.3239 for C<sub>27</sub>H<sub>42</sub>O<sub>4</sub> [M]<sup>+</sup>, found 430.3240.

**3.2.17. 3,4-Dihydroxybenzyl cis-5,8,11,14,17-eicosapentanoate 21.** 33%. Light yellow syrup; <sup>1</sup>H NMR (300 MHz, CDCl<sub>3</sub>): δ 6.88 (s, 1H, ar), 6.81 (dd, AB system, *J* = 8.1 Hz, 2H ar), 5.35 (m, 10H, HC=CH), 4.99 (s, 2H, PhCH<sub>2</sub>OOC–), 2.80 (m, 8H, –HC=CH–CH<sub>2</sub>–HC=CH–), 2.34 (t, *J* = 7.4 Hz, 2H, –OOC–CH<sub>2</sub>–), 2.06 (m, 4H, –HC=CH–CH<sub>2</sub>–CH<sub>3</sub>, –HC=CH–CH<sub>2</sub>–CH<sub>2</sub>–) 1.69 (m, 2H, –CH<sub>2</sub>–CH<sub>2</sub>–COO–), 0.96 (t, *J* = 7.5 Hz, 3H, –CH<sub>3</sub>); <sup>13</sup>C NMR (75 MHz, CDCl<sub>3</sub>): δ 174.1 (–COO–), 144.0, 143.7, 132.1, 129.1, 128.9, 128.8, 128.6, 128.3, 128.2, 128.1, 127.9, 127.1, 121.6, 115.9, 115.3 (Ar, HC=CH–), 66.2 (PhCH<sub>2</sub>OOC–), 33.9, 33.3, 26.6, 26.5, 25.7, 25.6, 28.8, 24.6, 20.6 (–CH<sub>2</sub>–, –HC=CH–CH<sub>2</sub>–HC=CH–), 14.3

(–CH<sub>3</sub>); HRMS FAB+ calcd 447.5963 for C<sub>27</sub>H<sub>36</sub>O<sub>4</sub>Na [M+Na]<sup>+</sup>, found 447.5961.

**3.2.18. 2-(3,4-Dihydroxyphenyl) ethyl *cis*-5,8,11,14,17-eicosapentanoate 22.** 51%. Light yellow syrup; <sup>1</sup>H NMR (400 MHz, CDCl<sub>3</sub>): δ 6.78 (d, *J*=8.1 Hz, 1H, ar), 6.72 (d, *J*=2.0 Hz, 1H, ar), 6.63 (dd, *J*=8.0, 2.0 Hz, 1H, ar), 5.35 (m, 10H, HC=CH), 4.25 (t, *J*=7.1 Hz, 2H, –CH<sub>2</sub>OOC–), 2.81 (m, 8H, –HC=CH–CH<sub>2</sub>–HC=CH–), 2.80 (t, *J*=7.1 Hz, 2H, ar-CH<sub>2</sub>–), 2.29 (t, *J*=7.6 Hz, 2H, –OOC–CH<sub>2</sub>–), 2.07 (m, 4H, HC=CH–CH<sub>2</sub>–CH<sub>3</sub>, –HC=CH–CH<sub>2</sub>–CH<sub>2</sub>–), 1.67 (t, *J*=7.4 Hz, 2H, –CH<sub>2</sub>–CH<sub>2</sub>–COO–), 0.96 (t, *J*=7.5 Hz, 3H, –CH<sub>3</sub>); <sup>13</sup>C NMR (75 MHz, CDCl<sub>3</sub>): δ 174.1 (–COO–), 144.0, 142.7, 132.1, 129.1, 128.9, 128.7, 128.6, 128.3, 128.2, 128.0, 127.9, 127.1, 121.6, 115.9, 115.3 (Ar, HC=CH–), 66.2 (–CH<sub>2</sub>OCO–), 34.5, 33.9, 33.4, 26.6, 26.5, 25.7, 25.6, 24.6, 20.6 (–CH<sub>2</sub>–, –HC=CH–CH<sub>2</sub>–HC=CH–), 14.3 (–CH<sub>3</sub>); HRMS FAB+ calcd 461.6120 for C<sub>28</sub>H<sub>38</sub>O<sub>4</sub>Na [M+Na]<sup>+</sup>, found 461.6115.

**3.2.19. 3-(3,4-Dihydroxyphenyl) propyl *cis*-5,8,11,14,17-eicosapentanoate 23.** 97%. Light yellow syrup; <sup>1</sup>H NMR (400 MHz, CDCl<sub>3</sub>): δ 6.76 (d, *J*=8.1 Hz, 1H, ar), 6.72 (d, *J*=1.8 Hz, 1H, ar), 6.57 (dd, *J*=8.0, 1.8 Hz, 1H, ar), 5.37 (m, 10H, HC=CH), 4.07 (t, *J*=6.6 Hz, 2H, –CH<sub>2</sub>OOC–), 2.82 (m, 8H, –HC=CH–CH<sub>2</sub>–HC=CH–), 2.55 (t, *J*=7.1 Hz, 2H, ar-CH<sub>2</sub>–), 2.33 (t, *J*=7.5 Hz, 2H, –OOC–CH<sub>2</sub>–), 2.09 (m, 4H, HC=CH–CH<sub>2</sub>–CH<sub>3</sub>, –HC=CH–CH<sub>2</sub>–CH<sub>2</sub>–), 1.89 (q, *J*=6.8 Hz, 2H, –CH<sub>2</sub>–), 1.67 (t, *J*=7.4 Hz, 2H, –CH<sub>2</sub>–CH<sub>2</sub>–COO–), 0.96 (t, *J*=7.5 Hz, 3H, –CH<sub>3</sub>); <sup>13</sup>C NMR (75 MHz, CDCl<sub>3</sub>): δ 174.6 (–COO–), 143.8, 142.0, 134.1, 132.2, 129.0, 128.9, 128.7, 128.4, 128.3, 128.2, 127.9, 127.1, 120.7, 115.6, 115.4 (Ar, HC=CH–), 64.1 (–CH<sub>2</sub>OCO–), 33.9, 31.5, 30.3, 26.7, 25.7, 25.6, 24.9, 20.7 (–CH<sub>2</sub>–, –HC=CH–CH<sub>2</sub>–HC=CH–), 14.3 (–CH<sub>3</sub>); HRMS FAB+ calcd 475.6277 for C<sub>29</sub>H<sub>40</sub>O<sub>4</sub>Na [M+Na]<sup>+</sup>, found 475.6269.

**3.2.20. 3,4-Dihydroxycinnamyl *cis*-5,8,11,14,17-eicosapentanoate 24.** 32%. Light yellow syrup; <sup>1</sup>H NMR (300 MHz, CDCl<sub>3</sub>): δ 6.92 (s, 1H, ar), 6.80 (s, 2H, ar), 6.51 (d, *J*=15.8 Hz, 1H, Ph-CH=CH–CH<sub>2</sub>–), 6.09 (dt, *J*=15.8, 6.6 Hz, 1H, Ph-CH=CH–CH<sub>2</sub>–), 5.36 (m, 10H, HC=CH), 4.69 (d, *J*=6.6 Hz, Ph-CH=CH–CH<sub>2</sub>–), 2.82 (m, 8H, –HC=CH–CH<sub>2</sub>–HC=CH–), 2.36 (t, *J*=7.4 Hz, 2H, –OOC–CH<sub>2</sub>–), 2.06 (m, 4H, –HC=CH–CH<sub>2</sub>–CH<sub>3</sub>, –HC=CH–CH<sub>2</sub>–CH<sub>2</sub>–) 1.72 (q, *J*=7.4 Hz, 2H, –CH<sub>2</sub>–CH<sub>2</sub>–COO–), 0.96 (t, *J*=7.5 Hz, 3H, –CH<sub>3</sub>); <sup>13</sup>C NMR (75 MHz, CDCl<sub>3</sub>): δ 174.0 (–COO–), 144.0, 143.8, 134.1, 132.2, 129.0, 128.9, 128.7, 128.4, 128.3, 128.2, 127.9, 127.1, 121.1, 120.7, 115.6, 115.4 (Ar, HC=CH–), 65.4 (–CH<sub>2</sub>OCO–), 33.8, 26.6, 25.7, 25.6, 24.8, 20.6 (–CH<sub>2</sub>–, –HC=CH–CH<sub>2</sub>–HC=CH–), 14.3 (–CH<sub>3</sub>); HRMS FAB+ calcd 473.6265 for C<sub>29</sub>H<sub>38</sub>O<sub>4</sub>Na [M+Na]<sup>+</sup>, found 473.6254.

**3.2.21. 3,4-Dihydroxybenzyl *cis*-4,7,10,13,16,19-docosahexanoate 25.** 32%. Light yellow syrup; <sup>1</sup>H NMR (300 MHz, CDCl<sub>3</sub>): δ 6.88 (d, *J*=1.6 Hz, 1H, ar), 6.83 (d, *J*=8.0 Hz, 1H, ar), 6.78 (dd, *J*=8.0, 1.7 Hz, 1H, ar), 5.38 (m, 12H, HC=CH), 4.99 (s, 2H, –CH<sub>2</sub>OOC–), 2.83 (m, 10H, –HC=CH–CH<sub>2</sub>–HC=CH–), 2.40 (m, 2H, –OOC–CH<sub>2</sub>–), 2.39 (m, 2H, –HC=CH–CH<sub>2</sub>–CH<sub>2</sub>–COO–) 2.06 (q,

*J*=7.4 Hz, 2H, –HC=CH–CH<sub>2</sub>–CH<sub>3</sub>), 0.96 (t, *J*=7.5 Hz, 3H, –CH<sub>3</sub>); <sup>13</sup>C NMR (75 MHz, CDCl<sub>3</sub>): δ 173.6 (–COO–), 144.0, 143.7, 132.2, 129.7, 129.5, 128.8, 128.7, 128.4, 128.3, 128.2, 128.1, 128.0, 127.8, 127.6, 127.1, 121.6, 115.9, 115.4 (Ar, HC=CH–), 66.4 (PhCH<sub>2</sub>OCO–), 34.5, 33.8, 25.7, 25.7, 25.6, 22.9, 22.6, 20.6 (–CH<sub>2</sub>–, –HC=CH–CH<sub>2</sub>–HC=CH–), 14.3 (–CH<sub>3</sub>); HRMS FAB+ calcd 473.6215 for C<sub>29</sub>H<sub>38</sub>O<sub>4</sub>Na [M+Na]<sup>+</sup>, found 473.6208.

**3.2.22. 2-(3,4-Dihydroxyphenyl) ethyl *cis*-4,7,10,13,16,19-docosahexanoate 26.** 43%. Light yellow syrup; <sup>1</sup>H NMR (400 MHz, CDCl<sub>3</sub>): δ 6.78 (d, *J*=8.1 Hz, 1H, ar), 6.72 (d, *J*=2.0 Hz, 1H, ar), 6.58 (dd, *J*=8.0, 2.0 Hz, 1H, ar), 5.38 (m, 12H, HC=CH), 4.23 (t, *J*=7.1 Hz, 2H, –CH<sub>2</sub>OOC–), 2.81 (m, 10H, –HC=CH–CH<sub>2</sub>–HC=CH–), 2.80 (t, *J*=7.1 Hz, 2H, ar-CH<sub>2</sub>–), 2.35 (m, 2H, –OOC–CH<sub>2</sub>–), 2.35 (m, 2H, –HC=CH–CH<sub>2</sub>–CH<sub>2</sub>–COO–) 2.06 (m, *J*=7.6 Hz, 2H, –HC=CH–CH<sub>2</sub>–CH<sub>3</sub>), 0.96 (t, *J*=7.5 Hz, 3H, –CH<sub>3</sub>); <sup>13</sup>C NMR (75 MHz, CDCl<sub>3</sub>): δ 174.3 (–COO–), 144.0, 143.7, 132.2, 129.7, 129.5, 128.8, 128.7, 128.4, 128.3, 128.2, 128.1, 128.0, 127.8, 127.6, 127.1, 121.6, 115.9, 115.4 (Ar, HC=CH–), 66.4 (–CH<sub>2</sub>OCO–), 34.5, 33.8, 25.7, 25.7, 25.6, 22.9, 22.6, 20.6 (–CH<sub>2</sub>–, –HC=CH–CH<sub>2</sub>–HC=CH–), 14.3 (–CH<sub>3</sub>); HRMS FAB+ calcd 487.6572 for C<sub>30</sub>H<sub>40</sub>O<sub>4</sub>Na [M+Na]<sup>+</sup>, found 487.6562.

**3.2.23. 3-(3,4-Dihydroxyphenyl) propyl *cis*-4,7,10,13,16,19-docosahexanoate 27.** 67%. Light yellow syrup; <sup>1</sup>H NMR (400 MHz, CDCl<sub>3</sub>): δ 6.76 (d, *J*=8.1 Hz, 1H, ar), 6.68 (d, *J*=1.8 Hz, 1H, ar), 6.58 (dd, *J*=8.0, 1.8 Hz, 1H, ar), 5.38 (m, 12H, HC=CH), 4.08 (t, *J*=6.7 Hz, 2H, –CH<sub>2</sub>OOC–), 2.84 (m, 10H, –HC=CH–CH<sub>2</sub>–HC=CH–), 2.56 (t, *J*=7.4 Hz, 2H, ar-CH<sub>2</sub>–), 2.38 (m, 2H, –OOC–CH<sub>2</sub>–), 2.38 (m, 2H, –HC=CH–CH<sub>2</sub>–CH<sub>2</sub>–COO–) 2.08 (q, *J*=7.3 Hz, 2H, –HC=CH–CH<sub>2</sub>–CH<sub>3</sub>), 1.89 (q, *J*=6.9 Hz, 2H, –CH<sub>2</sub>–), 0.96 (t, *J*=7.5 Hz, 3H, –CH<sub>3</sub>); <sup>13</sup>C NMR (75 MHz, CDCl<sub>3</sub>): δ 173.7 (–COO–), 144.0, 143.7, 132.2, 129.7, 129.5, 128.8, 128.7, 128.4, 128.3, 128.2, 128.1, 128.0, 127.8, 127.6, 127.1, 121.6, 115.9, 115.4 (Ar, HC=CH–), 66.4 (–CH<sub>2</sub>OCO–), 34.3, 31.4, 30.3, 25.7, 25.6, 25.6, 22.9, 20.6 (–CH<sub>2</sub>–, –HC=CH–CH<sub>2</sub>–HC=CH–), 14.3 (–CH<sub>3</sub>); HRMS FAB+ calcd 501.6729 for C<sub>31</sub>H<sub>42</sub>O<sub>4</sub>Na [M+Na]<sup>+</sup>, found 501.6716.

**3.2.24. 3,4-Dihydroxycinnamyl *cis*-4,7,10,13,16,19-docosahexanoate 28.** 29%. Light yellow syrup; <sup>1</sup>H NMR (300 MHz, CDCl<sub>3</sub>): δ 6.92 (s, 1H, ar), 6.80 (s, 2H, ar), 6.51 (d, *J*=15.8 Hz, 1H, Ph-CH=CH–CH<sub>2</sub>–), 6.09 (dt, *J*=15.8, 6.6 Hz, 1H, Ph-CH=CH–CH<sub>2</sub>–), 5.36 (m, 12H, HC=CH), 4.69 (d, *J*=6.6 Hz, Ph-CH=CH–CH<sub>2</sub>–), 2.83 (m, 10H, –HC=CH–CH<sub>2</sub>–HC=CH–), 2.41 (m, 2H, –OOC–CH<sub>2</sub>–), 2.39 (m, 2H, –HC=CH–CH<sub>2</sub>–CH<sub>2</sub>–COO–) 2.07 (q, *J*=7.1 Hz, 2H, –HC=CH–CH<sub>2</sub>–CH<sub>3</sub>), 0.96 (t, *J*=7.5 Hz, 3H, –CH<sub>3</sub>); <sup>13</sup>C NMR (75 MHz, CDCl<sub>3</sub>): δ 173.6 (–COO–), 144.0, 143.8, 134.2, 132.1, 129.7, 129.5, 128.6, 128.4, 128.3, 128.2, 128.1, 128.0, 127.8, 127.1, 121.1, 120.2, 115.4, 113.2 (Ar, HC=CH–), 65.5 (–CH<sub>2</sub>OCO–), 34.4, 25.7, 25.6, 22.9, 20.6 (–CH<sub>2</sub>–, –HC=CH–CH<sub>2</sub>–HC=CH–), 14.3 (–CH<sub>3</sub>); HRMS FAB+ calcd 499.6705 for C<sub>31</sub>H<sub>40</sub>O<sub>4</sub>Na [M+Na]<sup>+</sup>, found 499.6710.

## References and notes

1. Regnström, J.; Nilsson, J.; Tornvall, P.; Landou, C.; Hamsten, A. *Lancet* **1992**, *339*, 1183–1186.
2. Ross, R. *Nature* **1993**, 801–809.
3. Berliner, J. A.; Navab, M.; Fogelman, A. M.; Frank, J. S.; Demer, L. L.; Edwards, P. A.; Watson, A. D.; Lusis, A. J. *Circulation* **1995**, 2488–2496.
4. Block, G. A. *Nutr. Rev.* **1992**, *50*, 207–213.
5. Auroma, O. I.; Deiane, M.; Jenner, A.; Halliwell, B.; Kaur, M.; Banni, S.; Corongiu, F. P.; Dessí, M. A.; Aesbach, R. *J. Agric. Food Chem.* **1998**, *46*, 5181–5187.
6. Visioli, F.; Bellomo, G.; Montedoro, G.; Galli, C. *Atherosclerosis* **1995**, *117*, 25–32.
7. Petroni, A.; Blasevich, M.; Salami, M.; Papini, M.; Montedoro, G. F.; Galli, C. *Thromb. Res.* **1995**, *78*, 151–160.
8. De la Puerta, R.; Ruiz-Gutierrez, V.; Hoult, J. R. *Biochem. Pharmacol.* **1999**, *57*, 445–449.
9. Owen, R. W.; Giacosa, A.; Hull, W. E.; Haubner, R.; Spiegelhalder, B.; Bartsch, H. *Eur. J. Cancer* **2000**, *36*, 1235–1247.
10. Manna, C.; Galletti, P.; Cucciolla, V.; Moltedo, O.; Leone, A.; Zappia, V. *J. Nutr.* **1997**, *127*, 286–292.
11. Lodyato, V. I.; Yurkova, I. L.; Sorokin, V. L.; Shadyro, O. I.; Dolgopalets, V. I.; Kisel, M. A. *Bioorg. Med. Chem. Lett.* **2003**, *13*, 1179–1182.
12. Lewis, P. T.; Wähälä, K.; Hoikkala, A.; Mutikainen, I.; Meng, Q.-H.; Adlercreutz, H.; Tikkanen, M. T. *Tetrahedron* **2000**, 7805–7810.
13. Humeau, C.; Girardin, M.; Rovel, B.; Miclo, A. *J. Mol. Catal. B* **1998**, 19–23.
14. Schuler, P. In *Food Antioxidants*; Hudson, B. J. F., Ed.; Elsevier: London, UK, 1990; pp 113–127.
15. Guyot, B.; Bosquette, B.; Pina, M.; Graille, J. *Biotechnol. Lett.* **1997**, *19*, 529–532.
16. Stamatis, H.; Sereti, V.; Kosilis, F. *JAOCS* **1999**, *76*, 1505–1510.
17. Twu, Y.-K.; Shih, I.-L.; Yen, Y.-H.; Ling, Y.-F.; Shieh, C.-J. *J. Agric. Food Chem.* **2005**, *53*, 1012–1016.
18. Buisman, G. J. H.; van Helteren, C. T. W.; Kramer, G. F. H.; Veldsink, J. W.; Derksen, J. T. P.; Cuperus, F. P. *Biotechnol. Lett.* **1998**, *20*, 131–136.
19. González Alcudia, F.; Cert Ventulá, A.; Espartero Sánchez, J. L.; Mateo Briz, R.; Trujillo Pérez-Lanzac, M. PCT Patent WO 2004/005237.
20. Capasso, R.; Evidente, A.; Avolio, S.; Solla, F. *J. Agric. Food Chem.* **1999**, *47*, 1745–1748.
21. Yan, Y.; Bornscheuer, U. T.; Schmid, R. D. *Biotechnol. Lett.* **1999**, *21*, 1051–1054.

# Asymmetric biocatalytic hydrocyanation of pyrrole carboxaldehydes

Thomas Purkarthofer,<sup>a</sup> Karl Gruber,<sup>b</sup> Martin H. Fechter<sup>a</sup> and Herfried Griengl<sup>a,\*</sup>

<sup>a</sup>Research Centre Applied Biocatalysis, Institute of Organic Chemistry, Graz University of Technology, Stremayrgasse 16, A-8010 Graz, Austria

<sup>b</sup>Research Centre Applied Biocatalysis, Institute of Chemistry, Karl-Franzens University Graz, Heinrichstrasse 28, A-8010 Graz, Austria

Received 2 March 2005; revised 25 May 2005; accepted 31 May 2005

Available online 23 June 2005

**Abstract**—The asymmetric hydrocyanation of pyrrole-2- and -3-carboxaldehydes substituted with either methyl, benzyl or phenyl in the 1-position catalyzed by the hydroxynitrile lyases from *Hevea brasiliensis* (*HbHNL*) and *Prunus amygdalus* (*PaHNL*) is reported. The products could be isolated—after *O*-silylation—with moderate to good enantiomeric purity although the carbonyl activity of the substrates was found to be very low, which is supported by quantum-chemical calculations. Structural effects concerning substrate size and regiochemistry are discussed considering docking calculations based on the X-ray crystal structures of the two enzymes. From these calculations one particular amino acid residue (Trp-128) in the active site of *HbHNL* could be identified, which plays a major role for the appropriate binding of structurally demanding carbonyl compounds.

© 2005 Elsevier Ltd. All rights reserved.

## 1. Introduction

The enzyme mediated synthesis of enantiomerically enriched cyanohydrins from aldehydes and ketones has been extensively explored for many years.<sup>1</sup> These compounds are important synthetic intermediates for the production of valuable biologically active substances.<sup>2</sup>

Among hydroxynitrile lyases (HNLs), the biocatalysts that catalyze the addition of hydrogen cyanide to carbonyl compounds resulting in the formation of cyanohydrins, the HNLs from the tropical rubber tree (*Hevea brasiliensis*, *HbHNL*, E.C. 4.1.2.39) and from almonds (*Prunus amygdalus*, *PaHNL*, E.C. 4.1.2.10) belong to the most comprehensively studied enzymes of this class. Both are characterized by their enormously high substrate tolerance that ranges from saturated and unsaturated aliphatic to aromatic and heterocyclic aldehydes and ketones. In addition, the two aforementioned enzymes are enantio-complementary. *HbHNL* preferentially catalyzes the synthesis of *S*-configured cyanohydrins whereas in the presence of *PaHNL* the addition of cyanide to the carbonyl function occurs predominantly in an *R*-selective manner.<sup>3</sup>

Even though a wide range of different substrates have been converted successfully, within the group of heterocyclic aromatic aldehydes only furan-2- and -3-carboxaldehydes and thiophene-2- and -3-carboxaldehydes turned out to be suitable substrates for *HbHNL* and *PaHNL*.<sup>1d,4</sup> However, pyrrole-2-carboxaldehyde could not be converted to the corresponding cyanohydrin using HNLs.<sup>4b,5</sup>

Recently, this fact has been attributed to the N–H function of the pyrrole ring and several *N*-substituted derivatives of pyrrole-2-carboxaldehyde were subjected to the reaction with HCN in the presence of a *PaHNL* preparation in organic solvents.<sup>6</sup>

As part of our efforts to extend the substrate spectrum of HNLs and to understand the influence of substrate structure on HNL-catalyzed hydrocyanations, we undertook a series of experiments investigating the addition of HCN to *N*-substituted pyrrole-2- and -3-carboxaldehydes under the catalytic action of both *HbHNL* and *PaHNL*.

Furthermore, to gain more detailed insight and to learn more about the binding mode of the examined cyanohydrins compared to mandelonitrile docking calculations were performed based on the recently elucidated X-ray crystal structures of *HbHNL* and *PaHNL*.<sup>7</sup>

These results allow for general conclusions concerning the

**Keywords:** Hydroxynitrile lyase; Enzymes; Biocatalysis; Heterocycles; Molecular modeling.

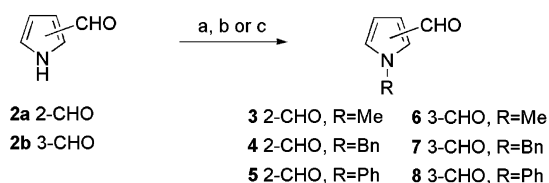
\* Corresponding author. Tel.: +43 316 873 8240; fax: +43 316 873 8740; e-mail: [office.orgc@tugraz.at](mailto:office.orgc@tugraz.at)

structural requirement of both enzymes regarding substrate size and regiochemistry.

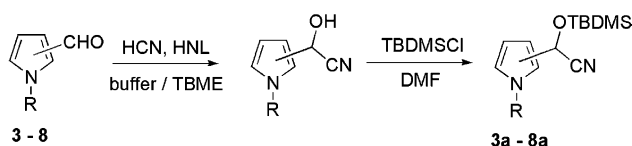
## 2. Results and discussion

Pyrrole-2- and -3-carboxaldehyde substituted at the 1-position with either methyl, benzyl, or phenyl were used as starting materials in this study.

Pyrrole-2-carboxaldehyde (**2a**) and *N*-methylpyrrole-2-carboxaldehyde (**3**) are commercially available. Pyrrole-3-carboxaldehyde (**2b**) was prepared by Vilsmeier-Haack



**Scheme 1.** (a) CH<sub>3</sub>I, KO<sup>t</sup>Bu, 18-crown-6, cyclohexane/DMSO; (b) benzyl bromide, TBABr, 50% aqueous NaOH, CH<sub>2</sub>Cl<sub>2</sub>; (c) phenylboronic acid, triethylamine, Cu(OAc)<sub>2</sub>, CH<sub>2</sub>Cl<sub>2</sub>.



**Scheme 2.** Synthesis of protected cyanohydrins.

formylation of *N*-triisopropylsilyl pyrrole (**1**), which was obtained by silylation of pyrrole with triisopropylsilyl chloride.<sup>8</sup> *N*-Methylpyrrole-3-carboxaldehyde (**6**) was obtained by methylation of **2b** using iodomethane in the presence of potassium *tert*-butoxide and 18-crown-6 in cyclohexane/DMSO.<sup>9</sup> Benzoylation of both **2a** and **2b** was carried out by employing benzyl bromide and tetrabutylammonium bromide in dichloromethane and aqueous sodium hydroxide as the base.<sup>10</sup> Aldehydes **5** and **8** were synthesized from **2a** and **2b**, respectively, using phenylboronic acid in combination with copper (II) acetate and triethylamine (**Scheme 1**).<sup>11</sup>

The enzyme catalyzed cyanohydrin reactions were carried out in a biphasic aqueous organic emulsion system (buffer/*tert*-butyl methyl ether).<sup>4d</sup> Since decomposition or racemization is likely to occur with cyanohydrins from aromatic aldehydes, all crude products were protected as TBDMS ethers without purification (**Scheme 2**). Analyses of the silylated cyanohydrins were performed either by chiral GC or by HPLC. The results obtained in the transformations catalyzed by either *HbHNL* or *PaHNL5* (isozyme #5 of the HNL from almonds)<sup>12</sup> are summarized in **Tables 1** and **2**.

With both biocatalysts *N*-methylated derivatives **3** and **6** turned out to be more reactive than the *N*-benzylated aldehydes **4** and **7** even considering that more HCN was applied in the transformation of **3** compared to **4**. On the other hand *N*-benzylated pyrrole-carboxaldehydes were converted with better stereoselectivities in most cases. With *HbHNL* both within the series of pyrrole-2- and -3-carboxaldehydes the protected cyanohydrins from the

**Table 1.** Synthesis of cyanohydrins from *N*-substituted pyrrole-2- and pyrrole-3-carboxaldehydes in the presence of the hydroxynitrile lyase from *H. brasiliensis*

	<i>t</i> <sup>a</sup> (d)	Yield <sup>b</sup> (%)	ee <sup>b</sup> (%)	HCN (equiv)	<i>t</i> <sup>a</sup> (d)	Yield <sup>b</sup> (%)	ee <sup>b</sup> (%)	HCN (equiv)	
<b>3</b> R=Me	8	17	5	10	<b>6</b> R=Me	11	64	40	10
<b>4</b> R=Bn	19	7	51	5	<b>7</b> R=Bn	10	35	91	10
<b>5</b> R=Ph	15	67	0	5	<b>8</b> R=Ph	21	0	—	10

<sup>a</sup> Corresponding to the enzymatic reaction.

<sup>b</sup> Determined after protection of the cyanohydrin with TBDMSCl.

**Table 2.** Synthesis of cyanohydrins from *N*-substituted pyrrole-2- and pyrrole-3-carboxaldehydes in the presence of the hydroxynitrile lyase from *P. amygdalus* (*PaHNL5*, Isoenzyme #5)

	<i>t</i> <sup>a</sup> (d)	Yield <sup>b</sup> (%)	ee <sup>b</sup> (%)	HCN (equiv)	<i>t</i> <sup>a</sup> (d)	Yield <sup>b</sup> (%)	ee <sup>b</sup> (%)	HCN (equiv)	
<b>3</b> R=Me	8	11	75	10	<b>6</b> R=Me	11	49	82	10
<b>4</b> R=Bn	19	2	29	5	<b>7</b> R=Bn	10	9	91	10
<b>5</b> R=Ph	15	11	0	5	<b>8</b> R=Ph	21	0	—	10

<sup>a</sup> Corresponding to the enzymatic reaction.

<sup>b</sup> Determined after protection of the cyanohydrin with TBDMSCl.

*N*-benzylated derivatives could be isolated with higher enantiomeric excesses, whereas with *PaHNL5* in the series of pyrrole-2-carboxaldehydes **3a** was formed with higher enantiomeric purity than **4a**. Aldehydes carrying a phenyl substituent at the 1-position (**5** and **8**) turned out to be unsuitable substrates for both HNLs, since in the case of **5** only racemic cyanohydrin could be detected and **8** did not furnish a product at all.

Analyzing the substrates (**3–8**) with respect to the position of the carbonyl group, similar trends could be observed with both enzymes. *N*-substituted pyrrole-3-carboxaldehydes **6** and **7** furnished the corresponding cyanohydrins with higher yields and ee compared to the corresponding starting materials **3** and **4** (again considering different amounts of HCN with **4** and **7**).

In general all substrates turned out to exhibit poor reactivities for cyanide addition leading to reaction times of several days. Quantum-chemical calculations of the reaction energy for the isodesmic reaction  $R-CHO + Ph-CH(O^-)-CN \rightarrow R-CH(O^-)-CN + Ph-CHO$  indicate that pyrrole-carboxaldehydes are considerably less reactive towards addition of cyanide compared to benzaldehyde as well as furan- and thiophene-carboxaldehydes (Table 3). These findings are well in line with our experimental results. The lower reactivity of pyrrole- versus furan- and thiophene-carboxaldehydes can be made plausible by a consideration of the mesomeric forms with participation of the heteroatom lone pair taking into account the heteroatom electronegativity and is also evident from infrared data, which show significantly lower wave numbers of the carbonyl stretch mode.<sup>13</sup> Furthermore, the same trend can be seen from the  $pK_a$  values of the corresponding carboxylic acids (pyrrole > thiophene > furan).<sup>14</sup>










As mentioned before, pyrrole-3-carboxaldehydes as compared to the 2-isomers were found to be more suitable substrates for the hydrocyanation reactions catalyzed by the hydroxynitrile lyases from *H. brasiliensis* and *P. amygdalus*. This trend is already evident in the estimated relative reactivities of these aldehydes (Table 3) indicating a higher reactivity of **6** compared to **3**, and it is likely to assume that the position of the carbonyl function on the aromatic ring has a greater impact on the intrinsic

reactivity of the aldehydes than the type of substituent attached to nitrogen. Secondly, the steric hindrance caused by the *N*-substituent is minimized in the case of the 3-isomers, which facilitates the appropriate binding of the aldehyde to the enzymes. In addition, the higher ee values of **4a** and **7a** (with the exception of **4a** in the *PaHNL5* series) can be ascribed to the decreased solubility of **4** and **7** compared to **3** and **6** in the aqueous phase resulting in a decreased rate of the unselective spontaneous HCN addition.

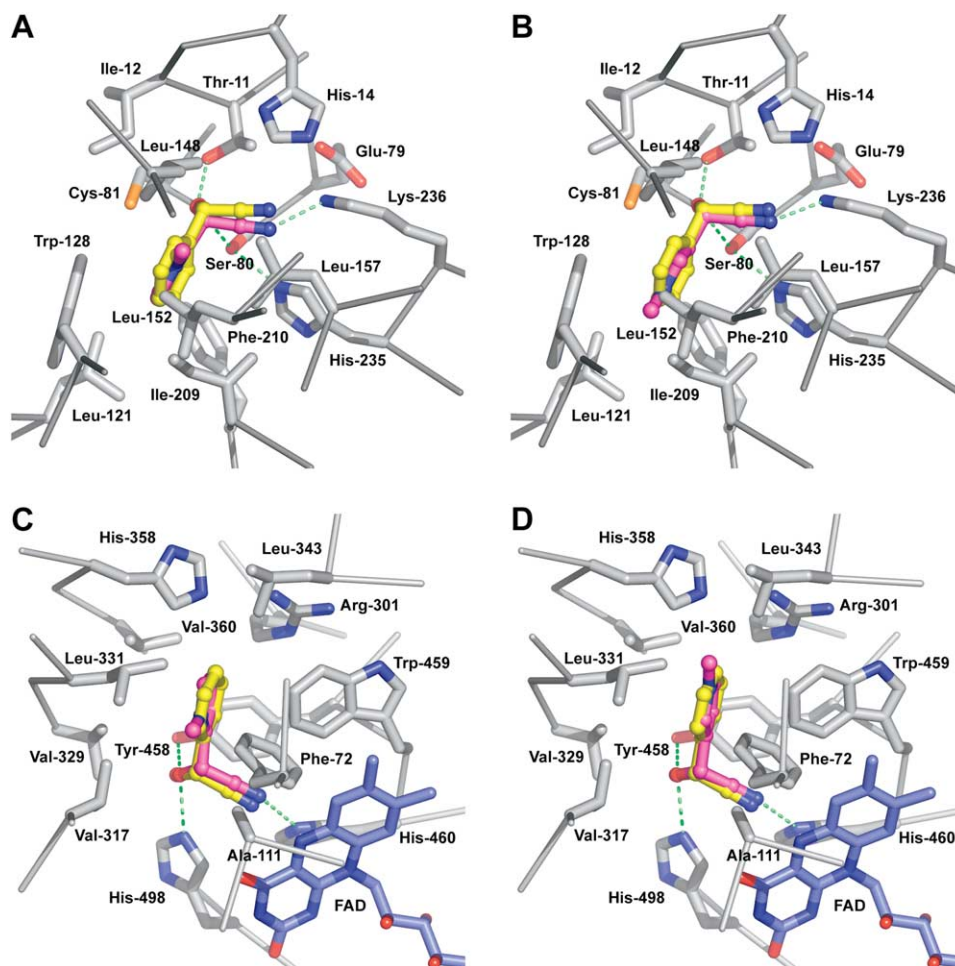
The corresponding cyanohydrins from aldehydes **3–8** were docked in silico to the active sites of *HbHNL* and *PaHNL5*. With the smaller cyanohydrins (**3a** and **6a**) these calculations revealed binding modes, which are virtually identical to the general binding mode of cyanohydrins observed experimentally.<sup>7a</sup> In the modeled complexes, the position of the pyrrole ring closely corresponds to the position of the phenyl ring in the respective complexes with mandelonitrile (Fig. 1).<sup>15</sup> In line with the known stereopreference of the two enzymes, *S*-configured cyanohydrins had more favourable calculated binding energies in the case of *HbHNL*, whereas docking of the *R*-enantiomers resulted—in case of *PaHNL5*—in lower energies. The respective energy differences between *R*- and *S*-enantiomers were comparable to those found in equivalent calculations with mandelonitrile.<sup>15a</sup> Thus, there appear to exist no steric reasons why pyrrole-carboxaldehydes (with no or small *N*-substituents) should not be accepted as substrates by *HbHNL* and *PaHNL5*. Therefore, the main reason for the unsatisfying results with substrates **3** and **6** seems to be—apart from the poor intrinsic carbonyl activity—the higher solubility in the aqueous phase and therefore increased unselective background reaction.

With larger cyanohydrins (*N*-benzyl and *N*-phenyl), no adequate binding modes to the active sites of both enzymes could be predicted in the calculations. For this reason amino acid residue Trp-128 in *HbHNL* was replaced by alanine in silico (W128A). As a consequence of this artificial mutation, binding modes for the cyanohydrins from **4** and **7** were identified, which show all characteristic features observed for cyanohydrin binding, such as the interaction of the cyano group with amino acid residue Lys-236 and hydrogen bonds of the hydroxyl function with Ser-80 and

**Table 3.** Relative reactivities of several aromatic aldehydes estimated from the isodesmic reaction  $R-CHO + Ph-CH(O^-)-CN \rightarrow R-CH(O^-)-CN + Ph-CHO$

Entry	Structure	$\Delta E$ (kcal/mol)	Entry	Structure	$\Delta E$ (kcal/mol)
1		-3.9	6		2.4
2		-1.9	7		2.4
3		-1.5	8		3.2
4		0.0	9		4.1
5		0.2			

Negative values indicate a higher reactivity, positive values indicate a lower reactivity towards addition of cyanide compared to benzaldehyde.

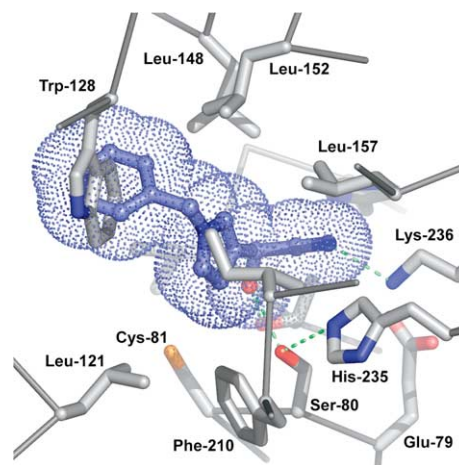


**Figure 1.** Modeled complexes of *HbHNL* and *PaHNL5* with cyanohydrins from *N*-methyl pyrrole-carboxaldehydes in comparison with bound mandelonitrile: (A) complex of *HbHNL* with unprotected *S*-3a, (B) complex of *HbHNL* with unprotected *S*-6a, (C) complex of *PaHNL5* with unprotected *R*-3a and (D) complex of *PaHNL5* with unprotected *R*-6a. The pyrrole derivatives are shown in magenta, mandelonitrile is shown in yellow. Surrounding active site residues (within 5 Å) are shown in grey. Potential hydrogen bonding interactions are indicated by green dashed lines. Figures 1 and 2 were produced using the program PyMol (<http://www.pymol.org>).

Thr-11. When the side chain of W128 (in its experimentally determined conformation)<sup>7a</sup> is reintroduced into the modeled complex of the W128A mutant and the benzylated substrate unprotected *S*-7a, severe steric clashes between the phenyl ring and the indole moiety of Trp-128 become evident (Fig. 2).

Thus, the most intriguing conclusion from these results is the indication of a pronounced flexibility of the bulky indole ring of Trp-128 in the wild type enzyme to allow larger carbonyl compounds—carrying hydrophobic groups—to be accommodated in the active site of *HbHNL*. Thereby, the large substituent (e.g., benzyl) is bound in a predominantly hydrophobic region. Furthermore, this result serves as a likely explanation for the fact that pyrrole-2-carboxaldehydes carrying more polar substituents such as *tert*-butoxycarbonyl, benzyloxycarbonyl or tosyl on the nitrogen atom could not be converted to the desired cyanohydrins in a stereoselective manner in the presence of *HbHNL* (data not given).

In the case of the phenyl substituted cyanohydrins, which lack the conformational flexibility provided by the



**Figure 2.** Modeled complex of *HbHNL* with the benzylated compound unprotected *S*-7a. This complex was modeled based on a modified protein structure in which Trp-128 was replaced by alanine. In this figure, however, Trp-128 is shown in the conformation which was observed in the crystal structure.<sup>7a</sup>

methylene group present in the benzyl derivatives, suitable complexes were not found even for the W128A mutein. Visual inspection of possible, productive binding modes (preserving the mechanistically important polar interactions with Ser-80, Thr-11 and Lys-236) revealed severe clashes of the phenyl ring with surrounding amino acids. Experimental data support this prediction (Tables 1 and 2). However, it remains unclear why racemic **5a** could be isolated after silylation whereas **8** did not react at all.

In the case of *PaHNL5*, it was not possible to identify one single amino acid residue playing a comparable role for the binding of structurally demanding substrates as indicated for Trp-128 in *HbHNL*. Nevertheless, similar conformational flexibility can be assumed to be responsible for the appropriate binding of benzylated aldehydes **4** and **7** since these substrates have been successfully converted to the corresponding enantiomerically enriched cyanohydrins **4a** and **7a** in the presence of *PaHNL5* (Table 2).

The complementary stereopreference of the two enzymes was sustained for the investigated substrates. According to chiral analyses, the dominating enantiomers obtained with *HbHNL* and *PaHNL5* had opposite absolute configurations in all cases.

### 3. Conclusion

Comparing the two enzymes, it can be concluded that upon *N*-alkylation pyrrole-carboxaldehydes can be transferred into the corresponding enantiomerically enriched cyanohydrins (at least **3**, **4**, **6** and **7**) in the presence of hydroxynitrile lyases from *H. brasiliensis* and *P. amygdalus* although with low to moderate yields and mostly moderate enantioselectivities. The enormously slow reaction rates seem to be due to the poor reactivity of the carbonyl group within this class of compounds (Table 3). Modeling calculations indicate the necessity of considerable flexibility of Trp-128 in the *Hevea* enzyme in order to adequately accommodate bulkier substrates. These predictions are consistent with the experimental results.

## 4. Experimental

### 4.1. Materials and methods

All solvents and materials not described in this chapter were commercially available and appropriately purified, if necessary. <sup>1</sup>H and <sup>13</sup>C NMR spectra were recorded on a Varian GEMINI 200 (<sup>1</sup>H 199.92 MHz, <sup>13</sup>C 50.25 MHz). HPLC analyses were performed using a CHIRALCEL OD-H column (from DAICEL) on an Agilent 1100 Series instrument equipped with a G1365B MWD UV detector (254 nm). HPLC solvents were purchased from Merck. GC analyses were carried out on a Hewlett Packard 6890 instrument equipped with a Chirasil-DEX CB column and a FID. Optical rotation was measured on a Perkin Elmer 341 polarimeter. Mass spectra (EI, 70 eV) were recorded on a KRATOS profile HV-4 double focussing magnetic sector instrument. TLC was performed on silica gel 60 F<sub>254</sub> aluminium plates (Merck), mixtures of cyclohexane and

EtOAc were used as eluent and compounds were detected with UV (254 nm) and spraying with Mo-reagent (10% H<sub>2</sub>SO<sub>4</sub>, 10% (NH<sub>4</sub>)<sub>6</sub>Mo<sub>7</sub>O<sub>24</sub>·4H<sub>2</sub>O, and 0.8% Ce(SO<sub>4</sub>)<sub>2</sub>·4H<sub>2</sub>O in water).

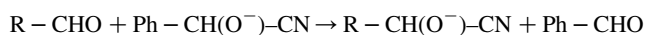
### 4.2. Docking calculations

Models for both enantiomers of the cyanohydrins **3a** to **8a** were built and optimized using the program Sybyl v6.5 (Tripos Inc.). Partial atomic charges for these compounds were calculated using the RESP protocol,<sup>16</sup> parameters for the oxidized FAD cofactor were kindly provided by Wohlfahrt.<sup>17</sup> For the hydroxynitrile lyase from *H. brasiliensis* (*HbHNL*), protein coordinates were taken from the respective atomic resolution X-ray crystal structure (PDB-entry: 1qj4).<sup>18</sup> For the enzyme from *P. amygdalus* (*PaHNL5*), a homology model of isoenzyme #5 was used as in a previous modeling study.<sup>12</sup> This model is based on the crystal structure of isoenzyme #1 (*PaHNL1*, PDB-entry: 1ju2)<sup>7b</sup>, which shares about 75% sequence identity. In both protein models, Asp-, Glu-, Arg- and Lys-residues were treated as charged. Protonation and tautomerization states of His-residues were chosen that resulted in sensible hydrogen bonding networks. Hydrogen atoms were added to the structure, followed by a geometry optimization using AMBER 6.0<sup>19</sup> applying harmonic restraints on the positions of all heavy atoms. Only polar hydrogen atoms of the protein and the ligands were retained for the docking simulations.

The cyanohydrins were docked to these sites with the program AutoDock v3.0<sup>20</sup> restricting the search to a 22.5 Å cube. In all calculations employing a genetic algorithm optimization, the proteins were kept rigid, while the position and orientation of the ligands as torsion angles around single bonds were allowed to vary. Twenty five independent simulations with populations consisting of 50 random structures evolving in about 90–100 generations were performed. The best individual of each generation automatically survived. The probability for performing a local search (consisting up to 300 iterations) of a pseudo Solis & Wets optimization<sup>21</sup> was 10%. The lowest energy structures of each independent run were clustered using an rms-tolerance of 1.5 Å.

### 4.3. Quantum-chemical calculations

Structures of aldehydes and the corresponding cyanide adducts were fully optimized at the B3LYP/6-31+g(d) level of theory using Gaussian03.<sup>22</sup> Solvation energies for an aqueous solution were estimated using the program Jaguar v4.2 (Schrodinger Inc.). Relative reactivities (compared to benzaldehyde) of aldehydes towards the addition of cyanide were estimated as the zero-point and solvation corrected reaction energies of the isodesmic reaction:



### 4.4. Syntheses

**4.4.1. *N*-Triisopropylsilylpyrrole (1).**<sup>8b</sup> To a stirred



solution of freshly distilled diisopropylamine (36.7 mL, 260 mmol) in 40 mL anhydrous THF was added a solution of *n*-butyllithium (2.5 M in hexane, 104 mL, 260 mmol) at  $-80^{\circ}\text{C}$  under an argon atmosphere. The solution was allowed to warm to room temperature. After rapid cooling to  $-80^{\circ}\text{C}$  pyrrole (18.0 mL, 259 mmol) was added and the solution was allowed to warm to room temperature again. After rapid cooling to  $-80^{\circ}\text{C}$  triisopropylsilylchloride (50.0 mL, 236 mmol) was added. After stirring for additional 15 h the solvent volume was reduced to 150 mL and the reaction mixture was partitioned between sat.  $\text{NaHCO}_3$  (200 mL) and dichloromethane (200 mL). The organic layer was dried over  $\text{Na}_2\text{SO}_4$  and removed under reduced pressure. Distillation of the residue afforded 48.9 g of **1** (93%) as a yellow liquid, bp  $87\text{--}89^{\circ}\text{C}/1.2$  mbar.  $^1\text{H}$  NMR (200 MHz,  $\text{CDCl}_3$ ):  $\delta = 1.12$  (d,  $J = 7$  Hz, 18H), 1.48 (sept,  $J = 7$  Hz, 3H), 6.34 (t, 2H), 6.82 (t, 2H) ppm.  $^{13}\text{C}$  NMR (50 MHz,  $\text{CDCl}_3$ ):  $\delta = 11.9, 18.0, 110.2, 124.2$  ppm. HRMS (EI):  $m/z$  calcd for  $\text{C}_{13}\text{H}_{25}\text{NSi}$ : 223.1756, found: 223.1760.

**4.4.2. Pyrrole-3-carboxaldehyde (2b).**<sup>8</sup> A solution of DMF (0.8 mL, 10.33 mmol) in 5 mL of dry dichloromethane was added dropwise to a stirred solution of oxalyl chloride (1.0 mL, 10.52 mmol) in 60 mL of dry dichloromethane at  $0^{\circ}\text{C}$ . The white suspension was stirred for 30 min at  $0^{\circ}\text{C}$  and then a solution of *N*-triisopropylsilylpyrrole (2.0 mL, 8.09 mmol) in 7 mL of dry dichloromethane was added rapidly. Subsequently the reaction mixture was heated to reflux for 30 min. The solvent was removed under reduced pressure almost quantitatively and the residue was stirred in a 5% aqueous sodium hydroxide solution at room temperature for 20 h. The solution was exhaustively extracted with dichloromethane in a continuous fashion. The organic layer was dried over  $\text{Na}_2\text{SO}_4$  and removed under reduced pressure. Purification by column chromatography (cyclohexane/EtOAc 3:1) yielded 0.52 g of **2b** (67%) as an orange oil.  $^1\text{H}$  NMR (200 MHz,  $\text{CDCl}_3$ ):  $\delta = 6.67$  (n.r., 1H), 6.85 (n.r., 1H), 7.48 (n.r., 1H), 9.80 (s, 1H) ppm.  $^{13}\text{C}$  NMR (50 MHz,  $\text{CDCl}_3$ ):  $\delta = 107.6, 121.2, 126.8, 128.2, 186.7$  ppm. HRMS (EI):  $m/z$  calcd for  $\text{C}_5\text{H}_5\text{NO}$ : 95.0371, found: 95.0350.

**4.4.3. *N*-Benzylpyrrole-2-carboxaldehyde (4).**<sup>10</sup> To a stirred solution of pyrrole-2-carboxaldehyde (3.1 g, 32.5 mmol) and tetrabutylammonium bromide (1.05 g, 3.25 mmol) in 30 mL of dichloromethane were added benzylbromide (4.0 mL, 37.2 mmol) at once and aqueous sodium hydroxide (9.0 g, 225 mmol in 18 mL of water) dropwise over a period of 0.5 h at  $0^{\circ}\text{C}$ . Subsequently the reaction mixture was heated to reflux for 1 h. After stirring for additional 15 h water (25 mL) and dichloromethane (50 mL) were added. The organic phase was washed with 2 M HCl (25 mL), sat.  $\text{NaHCO}_3$  (25 mL) and water (25 mL) and removed under reduced pressure. Distillation of the residue afforded 5.3 g of **4** (87%) as a brown oil, bp  $123\text{--}125^{\circ}\text{C}/1.4$  mbar.  $^1\text{H}$  NMR (200 MHz,  $\text{CDCl}_3$ ):  $\delta = 5.58$  (s, 2H), 6.29 (t,  $J = 3$  Hz, 1H), 6.99 (n.r., 2H), 7.17 (n.r., 2H), 7.30 (m, 3H), 9.57 (s, 1H) ppm.  $^{13}\text{C}$  NMR (50 MHz,  $\text{CDCl}_3$ ):  $\delta = 52.2, 110.4, 125.1, 127.5, 128.0, 129.0, 131.7, 131.8, 137.8, 179.8$  ppm. HRMS (EI):  $m/z$  calcd for  $\text{C}_{12}\text{H}_{11}\text{NO}$ : 185.0841, found: 185.0833.

**4.4.4. *N*-Phenylpyrrole-2-carboxaldehyde (5).** Pyrrole-2-carboxaldehyde (2.00 g, 21.03 mmol), phenylboronic acid (5.56 g, 45.60 mmol), copper (II) acetate (5.98 g, 32.92 mmol) and triethylamine (6.0 mL, 43.11 mmol) were stirred in 20 mL of anhydrous dichloromethane at room temperature for 18 h. The reaction mixture was filtered through Celite<sup>®</sup>, dried over  $\text{Na}_2\text{SO}_4$  and the solvent was removed under reduced pressure. Purification by column chromatography (cyclohexane/EtOAc 7:1) yielded 2.93 g of **5** (81%) as an orange oil.  $^1\text{H}$  NMR (200 MHz,  $\text{CDCl}_3$ ):  $\delta = 6.37$  (n.r., 1H), 7.04 (n.r., 1H), 7.14 (dd, 1H), 7.29–7.46 (m, 5H), 9.52 (s, 1H) ppm.  $^{13}\text{C}$  NMR (50 MHz,  $\text{CDCl}_3$ ):  $\delta = 111.2, 122.4, 126.3, 128.5, 129.4, 131.4, 132.8, 139.0, 179.4$  ppm. HRMS (EI):  $m/z$  calcd for  $\text{C}_{11}\text{H}_9\text{NO}$ : 171.0684, found: 171.0685.

**4.4.5. *N*-Methylpyrrole-3-carboxaldehyde (6).**<sup>9</sup> To a stirred solution of pyrrole-3-carboxaldehyde (1.30 g, 13.67 mmol) in 30 mL of cyclohexane/DMSO (2:1) was added potassium *tert*-butoxide (1.93 g, 17.20 mmol) and 18-crown-6 (440 mg, 1.66 mmol). Subsequently iodomethane (2.5 mL, 40.16 mmol) was added dropwise over a period of 10 min. After completion of the reaction (GC) water was added (35 mL) and the mixture was extracted with ethyl acetate ( $4 \times 40$  mL). The combined organic phases were dried over  $\text{Na}_2\text{SO}_4$  and the solvent was removed under reduced pressure. Purification by column chromatography (cyclohexane/EtOAc 2:1) yielded 1.27 g of **6** (85%) as a light brown liquid.  $^1\text{H}$  NMR (200 MHz,  $\text{CDCl}_3$ ):  $\delta = 3.70$  (s, 3H), 6.60 (n.r., 2H), 7.23 (n.r., 1H), 9.70 (s, 1H) ppm.  $^{13}\text{C}$  NMR (50 MHz,  $\text{CDCl}_3$ ):  $\delta = 37.0, 108.7, 124.6, 126.9, 130.1, 185.5$  ppm. HRMS (EI):  $m/z$  calcd for  $\text{C}_6\text{H}_7\text{NO}$ : 109.0528, found: 109.0522.

**4.4.6. *N*-Benzylpyrrole-3-carboxaldehyde (7).**<sup>10</sup> To a stirred solution of pyrrole-3-carboxaldehyde (1.00 g, 10.52 mmol) in 10 mL of dichloromethane was added tetra-*n*-butylammonium bromide (337 mg, 1.05 mmol) and benzyl bromide (1.50 mL, 12.63 mmol). Subsequently aqueous sodium hydroxide (4.2 g, 105 mmol in 10 mL of water) was added dropwise at  $0^{\circ}\text{C}$ . After completion of the addition, the solution was allowed to warm to room temperature. After 5 h 50 mL of a 10% HCl solution were added slowly and the phases were separated. The organic phase was washed with sat.  $\text{NaHCO}_3$ , dried over  $\text{Na}_2\text{SO}_4$  and removed under reduced pressure. Purification by column chromatography (cyclohexane/EtOAc 3:1) yielded 1.73 g of **7** (88%) as a yellow oil.  $^1\text{H}$  NMR (200 MHz,  $\text{CDCl}_3$ ):  $\delta = 5.09$  (s, 2H), 6.68 (m, 2H), 7.17 (m, 2H), 7.30–7.37 (m, 4H), 9.73 (s, 1H) ppm.  $^{13}\text{C}$  NMR (50 MHz,  $\text{CDCl}_3$ ):  $\delta = 54.2, 108.9, 124.0, 127.1, 127.6, 128.6, 129.3, 129.4, 136.4, 185.6$  ppm. HRMS (EI):  $m/z$  calcd for  $\text{C}_{12}\text{H}_{11}\text{NO}$ : 185.0841, found: 185.0842.

**4.4.7. *N*-Phenylpyrrole-3-carboxaldehyde (8).** Pyrrole-3-carboxaldehyde (1.50 g, 15.77 mmol), phenylboronic acid (3.85 g, 31.54 mmol), copper(II)acetate (4.30 g, 23.66 mmol) and triethylamine (4.6 mL, 33.12 mmol) were stirred in 40 mL of anhydrous dichloromethane at room temperature for 72 h. The reaction mixture was filtered through Celite<sup>®</sup>, dried over  $\text{Na}_2\text{SO}_4$  and the solvent was removed under reduced pressure. Purification by column chromatography (cyclohexane/EtOAc 7:1) yielded

1.16 g of **8** (43%) as a yellow oil.  $^1\text{H}$  NMR (200 MHz,  $\text{CDCl}_3$ ):  $\delta$  = 6.81 (dd,  $J$  = 3, 2 Hz, 1H), 7.09 (n.r., 1H), 7.36–7.50 (m, 5H), 7.67 (n.r., 1H), 9.86 (s, 1H) ppm.  $^{13}\text{C}$  NMR (50 MHz,  $\text{CDCl}_3$ ):  $\delta$  = 109.9, 121.4, 122.6, 127.4, 127.6, 128.4, 130.1, 139.8, 185.7 ppm. HRMS (EI):  $m/z$  calcd for  $\text{C}_{11}\text{H}_9\text{NO}$ : 171.0678, found: 171.0684.

**4.4.8. Synthesis and safe-handling of anhydrous HCN—CAUTION.** All reactions involving HCN or cyanides were carried out in a well ventilated hood. For continuous warning, an electrochemical sensor for HCN detection was used. The required amount of HCN was freshly prepared by dropping a saturated NaCN solution into aqueous sulfuric acid (60%) at 80 °C. HCN was transferred through a drying column in a nitrogen stream and collected in a cooling trap at –12 °C. Waste solutions containing cyanides were treated with aqueous sodium hypochlorite (10%). Subsequently the pH was adjusted to 7.0 with aqueous sulfuric acid.

**4.4.9. General procedure for the synthesis of racemic cyanohydrins.** *Procedure A.* To a stirred solution of the corresponding aldehyde in acetonitrile were added TBDMSCl (1.5 equiv), KCN (4 equiv) and a catalytic portion of  $\text{ZnI}_2$ . The reaction was stirred at room temperature and monitored by TLC. After completion of the reaction the mixture was partitioned between dichloromethane and a saturated solution of  $\text{NaHCO}_3$ . The organic layer was dried over  $\text{Na}_2\text{SO}_4$  and the solvent was removed under reduced pressure.

*Procedure B.* To a stirred solution of the corresponding aldehyde in *tert*-butyl methyl ether in the presence of Amberlyst-A21 was added HCN (10 equiv) via a syringe. The reaction was stirred at room temperature and monitored by TLC. After completion of the reaction, the solvent and HCN were removed under reduced pressure. Subsequently the crude cyanohydrins were silylated (see Section 4.4.11).

**4.4.10. General procedure for the enzymatic cyanohydrin reaction.** To a stirred solution of aldehyde in *tert*-butyl methyl ether was added a buffered (sodium citrate 100 mM) solution of the corresponding hydroxynitrile lyase (*HbHNL* pH = 4.8, *PaHNL5* pH = 3.5–4.0). After 10 min HCN (5 or 10 equiv, see Tables 1 and 2) was added and the mixture was stirred at 0 °C for approximately 2 h and subsequently allowed to warm to room temperature. For work-up Celite<sup>®</sup> was added and the mixture was transferred into a filter funnel containing  $\text{Na}_2\text{SO}_4$ . The product and remaining starting material were washed out with *tert*-butyl methyl ether. The collected solvent was removed under reduced pressure and the crude cyanohydrins were silylated (see Section 4.4.11).

**4.4.11. General procedure for silylation of crude cyanohydrins.** To a stirred solution of crude cyanohydrin in DMF was added imidazole (1.5 equiv) and TBDMSCl (1.2 equiv). The reaction was stirred at room temperature and monitored by TLC. After completion of the reaction dichloromethane was added and the mixture was extracted with HCl 10%, sat.  $\text{NaHCO}_3$  and water. The organic layer was dried over  $\text{Na}_2\text{SO}_4$  and removed under reduced pressure.

**4.4.12. *tert*-Butyl dimethylsilyloxy(*N*-methylpyrr-2-yl) acetonitrile (**3a**).** Purification by column chromatography (cyclohexane/EtOAc 2:1) yielded **3a** as a yellow oil.  $^1\text{H}$  NMR (200 MHz,  $\text{CDCl}_3$ ):  $\delta$  = 0.05 (s, 3H), 0.13 (s, 3H), 0.90 (s, 9H), 3.77 (s, 3H), 5.54 (s, 1H), 6.05 (t,  $J$  = Hz, 1H), 6.19 (dd,  $J$  = 3, 2 Hz, 1H), 6.69 (t,  $J$  = 2 Hz, 1H) ppm.  $^{13}\text{C}$  NMR (50 MHz,  $\text{CDCl}_3$ ):  $\delta$  = –5.1, –5.0, 18.3, 25.7, 34.6, 58.0, 107.4, 110.7, 118.4, 125.7, 126.2 ppm. HRMS (EI):  $m/z$  calcd for  $\text{C}_{13}\text{H}_{22}\text{N}_2\text{OSi}$ : 250.1492, found: 250.1501. (chiral GC analysis: Chirasil-DEX, 110 °C, 1 bar  $\text{H}_2$ ; ret. times: 11.4, 12.6 min).

**4.4.13. *tert*-Butyl dimethylsilyloxy(*N*-benzylpyrr-2-yl) acetonitrile (**4a**).** Purification by column chromatography (cyclohexane/EtOAc 20:1) yielded **4a** as a white solid (mp 35–37 °C).  $^1\text{H}$  NMR (200 MHz,  $\text{CDCl}_3$ ):  $\delta$  = 0.08 (s, 6H), 0.87 (s, 9H), 5.20 (d,  $J$  = 16 Hz, 1H), 5.31 (d,  $J$  = 16 Hz, 1H), 5.50 (s, 1H), 6.14 (t,  $J$  = 4 Hz, 1H), 6.33 (d,  $J$  = 4, 2 Hz, 1H), 6.67 (t,  $J$  = 2 Hz, 1H), 7.10 (m, 2H), 7.29–7.38 (m, 3H) ppm.  $^{13}\text{C}$  NMR (50 MHz,  $\text{CDCl}_3$ ):  $\delta$  = –5.1, –4.9, 18.3, 25.7, 51.1, 58.0, 108.0, 110.8, 118.5, 125.0, 126.7, 127.3, 128.0, 129.0, 137.5 ppm. HRMS (EI):  $m/z$  calcd for  $\text{C}_{19}\text{H}_{26}\text{N}_2\text{OSi}$ : 326.1827, found: 326.1814. (chiral HPLC analysis: CHIRALCEL OD-H, *n*-heptane/2-propanol 95:5, 0.5 mL/min, 10 °C; ret. times: 10.3, 13.6 min).

**4.4.14. *tert*-Butyl dimethylsilyloxy(*N*-phenylpyrr-2-yl) acetonitrile (**5a**).** Purification by column chromatography (cyclohexane/EtOAc 50:1) yielded **5a** as a dark yellow oil.  $^1\text{H}$  NMR (200 MHz,  $\text{CDCl}_3$ ):  $\delta$  = 0.1 (s, 3H), 0.04 (s, 3H), 0.85 (s, 9H), 5.48 (s, 1H), 6.29 (t,  $J$  = 3 Hz, 1H), 6.59 (dd,  $J$  = 3, 2 Hz, 1H), 6.87 (t,  $J$  = 2 Hz, 1H), 7.38–7.47 (m, 5H) ppm.  $^{13}\text{C}$  NMR (50 MHz,  $\text{CDCl}_3$ ):  $\delta$  = –5.0, –4.9, 18.2, 25.7, 57.2, 108.9, 112.1, 118.7, 125.2, 126.6, 127.9, 128.4, 129.6, 139.2 ppm. HRMS (EI):  $m/z$  calcd for  $\text{C}_{18}\text{H}_{24}\text{N}_2\text{OSi}$ : 312.1649, found: 312.1658. (chiral HPLC analysis: CHIRALCEL OD-H, *n*-heptane/2-propanol 99:1, 0.5 mL/min, 10 °C; ret. times: 9.9, 10.9 min).

**4.4.15. *tert*-Butyl dimethylsilyloxy(*N*-methylpyrr-3-yl) acetonitrile (**6a**).** Purification by column chromatography (cyclohexane/EtOAc 20:1) yielded **6a** as a light brown oil.  $^1\text{H}$  NMR (200 MHz,  $\text{CDCl}_3$ ):  $\delta$  = 0.15 (s, 3H), 0.18 (s, 3H), 0.93 (s, 9H), 3.64 (s, 3H), 5.48 (s, 1H), 6.18 (t,  $J$  = 3, 2 Hz, 1H), 6.57 (t,  $J$  = 3, 2 Hz, 1H), 6.73 (s, 1H) ppm.  $^{13}\text{C}$  NMR (50 MHz,  $\text{CDCl}_3$ ):  $\delta$  = –4.8, –4.7, 18.4, 25.8, 36.6, 59.0, 107.3, 120.1, 120.4, 120.5, 122.9 ppm. HRMS (EI):  $m/z$  calcd for  $\text{C}_{13}\text{H}_{22}\text{N}_2\text{OSi}$ : 250.1490, found: 250.1501. (chiral HPLC analysis: CHIRALCEL OD-H, *n*-heptane/2-propanol 95:5, 0.5 mL/min, 10 °C; ret. times: 10.9, 11.9 min).

**4.4.16. *tert*-Butyl dimethylsilyloxy(*N*-benzylpyrr-3-yl) acetonitrile (**7a**).** Purification by column chromatography (cyclohexane/EtOAc 50:1) yielded **7a** as a pale yellow oil.  $^1\text{H}$  NMR (200 MHz,  $\text{CDCl}_3$ ):  $\delta$  = 0.13 (s, 3H), 0.16 (s, 3H), 0.92 (s, 9H), 5.04 (s, 2H), 5.50 (s, 1H), 6.23 (t,  $J$  = 3, 2 Hz, 1H), 6.65 (t,  $J$  = 3, 2 Hz, 1H), 6.80 (s, 1H), 7.11–7.15 (m, 2H), 7.30–7.35 (m, 3H) ppm.  $^{13}\text{C}$  NMR (50 MHz,  $\text{CDCl}_3$ ):  $\delta$  = –4.8, –4.7, 18.4, 25.8, 53.8, 59.1, 107.7, 120.0, 120.1, 120.8, 122.4, 127.4, 128.2, 129.1, 137.6 ppm.  $[\alpha]_D^{20}$  –6.7 (c 0.52,  $\text{C}_2\text{H}_5\text{OH}$ , 91% ee, (S)). HRMS (EI):  $m/z$  calcd for  $\text{C}_{19}\text{H}_{26}\text{N}_2\text{OSi}$ : 326.1811, found: 326.1814. (chiral HPLC

analysis: CHIRALCEL OD-H, *n*-heptane/2-propanol 95:5, 0.5 mL/min, 10 °C; ret. times: 16.3, 21.8 min).

### Acknowledgements

The authors would like to thank Wolfgang Skranc and Marcel Wubbolts for scientific discussions and Birgit Krenn, Wernfried Haas and Martin Trötzlmüller for experimental work. Financial support by DSM Fine Chemicals Austria is gratefully acknowledged. Research Centre Applied Biocatalysis is funded by TIG (Technologie Impulse Gesellschaft m.b.H.), Vienna, the Province of Styria and the City of Graz.

### References and notes

- (a) Albers, H.; Hamann, K. *Biochem. Z.* **1934**, *269*, 14–25. (b) Becker, W.; Benthin, U.; Eschenhof, E.; Pfeil, E. *Biochem. Z.* **1963**, *337*, 156–166. (c) Becker, W.; Freund, H.; Pfeil, E. *Angew. Chem., Int. Ed. Engl.* **1965**, *4*, 1079. (d) Effenberger, F.; Ziegler, T.; Foerster, S. *Angew. Chem.* **1987**, *99*, 491–492. *Angew. Chem., Int. Ed. Engl.* **1987**, *99*, 458–460. (e) Brussee, J.; Roos, E. C.; van der Gen, A. *Tetrahedron Lett.* **1988**, *29*, 4485–4488.
- (a) Effenberger, F.; Eichhorn, J.; Roos, J. *Tetrahedron: Asymmetry* **1995**, *6*, 271–282. (b) Johnson, D. V.; Felfer, U.; Griengl, H. *Tetrahedron* **2000**, *56*, 781–790. (c) Johnson, D. V.; Fischer, R.; Griengl, H. *Tetrahedron* **2000**, *56*, 9289–9295. (d) Bühler, H.; Bayer, A.; Effenberger, F. *Chem. Eur. J.* **2000**, *6*, 2564–2571.
- (a) Fechter, M. H.; Griengl, H. Enzymatic Synthesis of Cyanohydrins. In *Enzyme Catalysis in Organic Synthesis*; Drauz, K., Waldmann, H., Eds.; Wiley-VCH: Weinheim, 2002; pp 974–989. (b) Gregory, R. J. H. *Chem. Rev.* **1999**, *99*, 3649–3682. (c) North, M. *Tetrahedron: Asymmetry* **2003**, *14*, 147–176.
- (a) Zandbergen, P.; van der Linden, J.; Brussee, J.; van der Gen, A. *Synth. Commun.* **1991**, *21*, 1387–1391. (b) Schmidt, M.; Hervé, S.; Klempier, N.; Griengl, H. *Tetrahedron* **1996**, *52*, 7833–7840. (c) Effenberger, F.; Eichhorn, J. *Tetrahedron: Asymmetry* **1997**, *8*, 469–476. (d) Griengl, H.; Klempier, N.; Pöchlauer, P.; Schmidt, M.; Shi, N.; Zabelinskaja-Mackova, A. A. *Tetrahedron* **1998**, *54*, 14477–14486.
- Lin, G.; Han, S.; Li, Z. *Tetrahedron* **1999**, *55*, 3531–3540.
- Chen, P.; Han, S.; Lin, G.; Huang, H.; Li, Z. *Tetrahedron: Asymmetry* **2001**, *12*, 3273–3279.
- (a) Gruber, K.; Gartner, G.; Krammer, B.; Schwab, H.; Kratky, C. *J. Biol. Chem.* **2004**, *279*, 20501–20510. (b) Dreveny, I.; Gruber, K.; Glieder, A.; Thompson, A.; Kratky, C. *Structure* **2001**, *9*, 803–815.
- (a) Bray, B. L.; Muchowski, J. M. *J. Org. Chem.* **1988**, *53*, 6115–6118. (b) Bray, B. L.; Mathies, P. H.; Naef, R.; Solas, D. R.; Tidwell, T. T.; Artis, D. R.; Muchowski, J. M. *J. Org. Chem.* **1990**, *55*, 6317–6328.
- Guida, W. C.; Mathre, D. J. *J. Org. Chem.* **1980**, *45*, 3172–3176.
- Brown, D.; Griffith, D.; Rider, M. E.; Smith, R. C. *J. Chem. Soc., Perkin Trans. 1* **1986**, 455–463.
- (a) Lam, P. Y. S.; Clark, C. G.; Saubern, S.; Adams, J.; Winters, M. P.; Chan, D. M. T.; Combs, A. *Tetrahedron Lett.* **1998**, *39*, 2941–2944. (b) Collot, V.; Bovy, P. R.; Rault, S. *Tetrahedron Lett.* **2000**, *41*, 9053–9057. (c) Yu, S.; Saenz, J.; Srirangam, J. K. *J. Org. Chem.* **2002**, *67*, 1699–1702.
- Glieder, A.; Weis, R.; Skranc, W.; Pöchlauer, P.; Dreveny, I.; Majer, S.; Schwab, H.; Gruber, K. *Angew. Chem.* **2003**, *115*, 4963–4966. *Angew. Chem., Int. Ed.* **2003**, *42*, 4815–4818.
- (a) Downie, I. M.; Earle, M. J.; Heaney, H.; Shuhaibar, K. F. *Tetrahedron* **1993**, *49*, 4015–4034. (b) Kolb, V. M.; Stupar, J. W.; Janota, T. E.; Duax, W. L. *J. Org. Chem.* **1989**, *54*, 2341–2346. (c) Markó, I. E.; Giles, P. R.; Tsukazaki, M.; Chellé-Regnaut, I.; Gautier, A.; Brown, S. M.; Urch, C. J. *J. Org. Chem.* **1999**, *64*, 2433–2439.
- (a) Lumme, P. O. *Suomen kem.* **1960**, *B33*, 87–93. (b) Fringuelli, F.; Marino, G.; Savelli, G. *Tetrahedron* **1969**, *25*, 5815–5818. (c) Butler, A. R. *J. Chem. Soc.* **1970**, *B*, 867–870.
- (a) Gruber, K. *Proteins: Struct. Funct. Genet.* **2001**, *44*, 26–31. (b) Dreveny, I.; Kratky, C.; Gruber, K. *Protein Sci.* **2002**, *11*, 292–300.
- Cieplak, P.; Cornell, W. D.; Bayly, C. I.; Kollman, P. A. *J. Comput. Chem.* **1995**, *16*, 1357–1377.
- Wohlfahrt, G.; Witt, S.; Hendle, J.; Schomburg, D.; Kalisz, H. M.; Hecht, H. J. *Acta Crystallogr. Sect. D* **1999**, *55*, 969–977.
- Gruber, K.; Gugganig, M.; Wagner, U. G.; Kratky, C. *Biol. Chem.* **1999**, *380*, 993–1000.
- Case, D. A.; Pearlman, D. A.; Caldwell, J. W.; Cheatham, T. E., III; Ross, W. S.; Simmerling, C. L.; Darden, T. A.; Merz, K. M.; Stanton, R. V.; Cheng, A. L.; Vincent, J. J.; Crowley, M.; Ferguson, D. M.; Radmer, R. J.; Seibel, G. L.; Singh, U. C.; Weiner, P. K.; Kollman, P. A. in *AMBER 6.0*; University of California: San Francisco, CA, 1997.
- Morris, G. M.; Goodsell, D. S.; Halliday, R. S.; Huey, R.; Hart, W. E.; Belew, R. K.; Olson, A. J. *J. Comput. Chem.* **1998**, *19*, 1639–1662.
- Solis, F. J.; Wets, R. J. B. *Math. Oper. Res.* **1981**, *6*, 19–30.
- Frisch, M. J.; Trucks, G. W.; Schlegel, H. B.; Scuseria, G. E.; Robb, M. A.; Cheeseman, J. R.; Montgomery, J. A.; Vreven, T.; Kudin, K. N.; Burant, J. C.; Millam, J. M.; Iyengar, S. S.; Tomasi, J.; Barone, V.; Mennucci, B.; Cossi, M.; Scalmani, G.; Rega, N.; Petersson, G. A.; Nakatsuji, H.; Hada, M.; Ehara, M.; Toyota, K.; Fukuda, R.; Hasegawa, J.; Ishida, M.; Nakajima, T.; Honda, Y.; Kitao, O.; Nakai, H.; Klene, M.; Li, X.; Knox, J. E.; Hratchian, H. P.; Cross, J. B.; Adamo, C.; Jaramillo, J.; Gomperts, R.; Stratmann, R. E.; Yazyev, O.; Austin, A. J.; Cammi, R.; Pomelli, C.; Ochterski, J. W.; Ayala, P. Y.; Morokuma, K.; Voth, G. A.; Salvador, P.; Dannenberg, J. J.; Zakrzewski, V. G.; Dapprich, S.; Daniels, A. D.; Strain, M. C.; Farkas, O.; Malick, D. K.; Rabuck, A. D.; Raghavachari, K.; Foresman, J. B.; Ortiz, J. V.; Cui, Q.; Baboul, A. G.; Clifford, S.; Cioslowski, J.; Stefanov, B. B.; Liu, G.; Liashenko, A.; Piskorz, P.; Komaromi, I.; Martin, R. L.; Fox, D. J.; Keith, T.; Al-Laham, M. A.; Peng, C. Y.; Nanayakkara, A.; Challacombe, M.; Gill, P. M. W.; Johnson, B.; Chen, W.; Wong, M. W.; Gonzalez, C.; Pople, J. A. in *Gaussian 03, revision B.4*, Gaussian, Inc., Pittsburgh, PA, 2003.

# Synthetic yeast oligomannosides as biological probes: $\alpha$ -D-Manp (1 $\rightarrow$ 3) $\alpha$ -D-Manp (1 $\rightarrow$ 2) $\alpha$ -D-Manp and $\alpha$ -D-Manp (1 $\rightarrow$ 3) $\alpha$ -D-Manp (1 $\rightarrow$ 2) $\alpha$ -D-Manp (1 $\rightarrow$ 2) $\alpha$ -D-Manp as Crohn's disease markers

Reynald Chevalier,<sup>a</sup> Jacques Esnault,<sup>a</sup> Peggy Vandewalle,<sup>b</sup> Boualem Sendid,<sup>b</sup>  
Jean-Frédéric Colombel,<sup>c</sup> Daniel Poulain<sup>b</sup> and Jean-Maurice Mallet<sup>a,\*</sup>

<sup>a</sup>École Normale Supérieure, Département de Chimie, associé au CNRS, 24 rue Lhomond, 75231 Paris cedex 05, France

<sup>b</sup>Équipe Inserm 0360 & Laboratoire de Mycologie Fondamentale et Appliquée, Faculté de Médecine Pôle Recherche, CHRU,  
Place de Verdun 59045, Lille Cedex, France

<sup>c</sup>Service de Gastroentérologie. Hôpital Huriez. Place de Verdun 59045 Lille Cedex, France

Received 13 January 2005; revised 25 May 2005; accepted 31 May 2005

Available online 21 June 2005

**Abstract**—The anti-*Saccharomyces cerevisiae* antibodies (ASCA) are markers for Crohn's disease used for diagnostic, phenotypic characterization and sero-epidemiological studies. Antibody detection is made by different immunoenzymatic tests using *S. cerevisiae* mannans which are both complex and poorly standardized antigens. Here we construct the major discriminating epitopes comprised within this antigen. When coupled to linker arm and a peptidic carrier to functionalize microtiter plates, they were able to discriminate serological responses between Crohn's disease and ulcerative colitis, another form of inflammatory bowel disease.  
© 2005 Elsevier Ltd. All rights reserved.

## 1. Introduction

Chronic inflammatory bowel diseases (IBD) including Crohn's disease (CD) and ulcerative colitis (UC), are common in developed countries. The diagnostic accuracy of conventional clinical, radiological, endoscopic and histological assessment in their diagnosis is generally good. Nevertheless diagnostic dilemmas sometimes persist and non-invasive accurate serological assays are still desirable. CD and not UC was found to be associated, in a large number of cases (60%),<sup>1</sup> to the presence of antibodies directed against *S. cerevisiae* mannan.<sup>2</sup> This observation has led to the development of a useful diagnostic test (the so-called ASCA test, anti-*Saccharomyces cerevisiae* antibodies).<sup>3</sup> However, ASCA test is not fully satisfactory, it uses as an antigen a not well defined mixture of oligosaccharides (various lengths and structures). The global antibody response assessed on such poorly standardized biological material has been shown to be not reproducible in several studies.<sup>4,5</sup> Two different studies

have shown that among the large number of carbohydrate epitopes expressed in *S. cerevisiae* mannan, the major epitopes were a trimannoside ( $\alpha$ -D-Manp (1  $\rightarrow$  3)  $\alpha$ -D-Manp (1  $\rightarrow$  2)  $\alpha$ -D-Manp)<sup>6</sup> and a tetramannoside ( $\alpha$ -D-Manp (1  $\rightarrow$  3)  $\alpha$ -D-Manp (1  $\rightarrow$  2)  $\alpha$ -D-Manp (1  $\rightarrow$  2)  $\alpha$ -D-Manp).<sup>7</sup> These oligomannosidic structures have been found only in yeast cell walls in *S. cerevisiae*,<sup>8,9</sup> *Candida albicans* and *C. stellatoidea*<sup>10–12</sup> mannans. They have been also found in glucosylated form in *Cryptococcus laurentii*<sup>13</sup> and in phosphorylated form in *Pichia holstii*.<sup>14</sup> In order to improve the selectivity of the ASCA test, we decided to design a more precise evaluation of antibodies directed against these two epitopes using synthetic oligomannosides.<sup>15</sup> Oligosaccharides are not able to bind directly to polystyrene plate, they are too hydrophilic. The binding is made possible through either a direct covalent coupling to chemically reactive microplate<sup>16</sup> or through formation of a neoglycopeptide. In this approach the oligomannosides were coupled first through a linker arm to a peptidic carrier.

We describe here the chemical synthesis<sup>17</sup> of two oligomannosides **1** and **2**, their conjugates to polylysine (Fig. 1), and their use for microplate functionalization.

Synthetic poly-L-lysine was selected here as chemically

**Keywords:** Oligomannoside; Crohn's disease; Polylysine; Glycoconjugates.

\* Corresponding author. Tel.: +33 1 44 32 33 37; fax: +33 1 44 32 33 97; e-mail: jean-maurice.mallet@ens.fr

<b>1</b>	$\alpha$ -D-Manp (1->3) $\alpha$ -D-Manp (1->2) $\alpha$ -D-Manp (1->2) $\alpha$ -D-Manp O (CH <sub>2</sub> ) <sub>8</sub> -COOH
<b>2</b>	$\alpha$ -D-Manp (1->3) $\alpha$ -D-Manp (1->2) $\alpha$ -D-Manp O (CH <sub>2</sub> ) <sub>8</sub> -COOH
<b>1-lys</b>	[ $\alpha$ -D-Manp (1->3) $\alpha$ -D-Manp (1->2) $\alpha$ -D-Manp (1->2) $\alpha$ -D-Manp O (CH <sub>2</sub> ) <sub>8</sub> -CO] <sub>x</sub> -poly-L-lysine
<b>2-lys</b>	[ $\alpha$ -D-Manp (1->3) $\alpha$ -D-Manp (1->2) $\alpha$ -D-Manp O (CH <sub>2</sub> ) <sub>8</sub> -CO] <sub>x</sub> -poly-L-lysine

**Figure 1.**

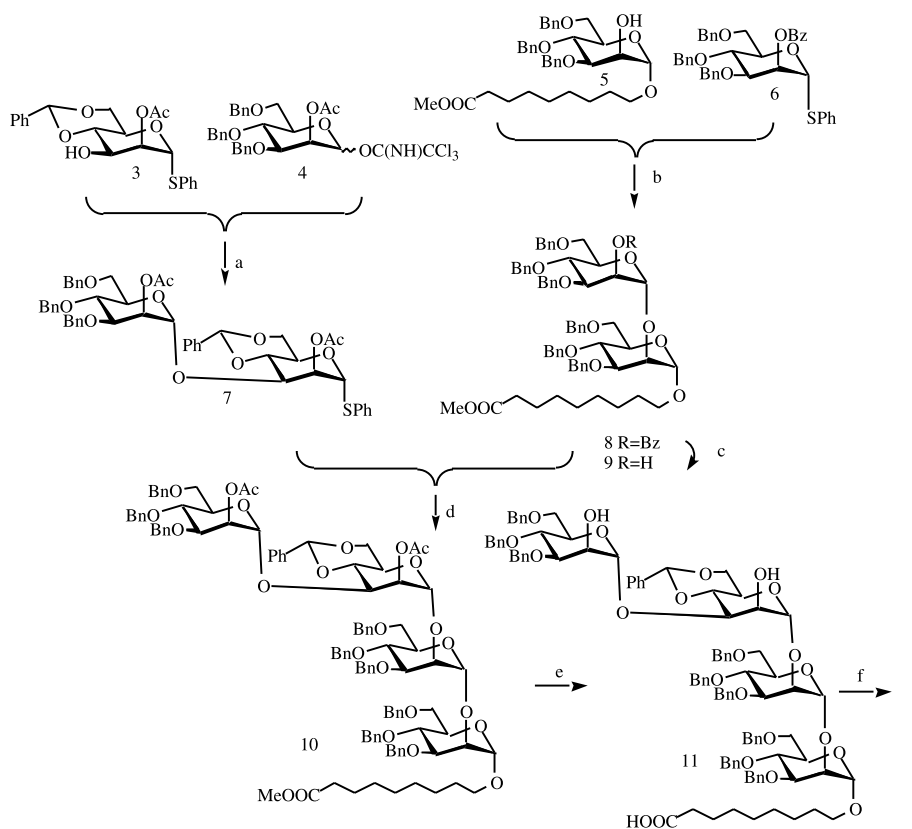
well defined carrier.<sup>18</sup> We report the diagnostic performance of a new immunoassay using this neo-antigen to functionalize microtiter plates in its ability to discriminate serological responses from patients with CD and UC.<sup>3</sup>

## 2. Chemical synthesis of 1 and 2

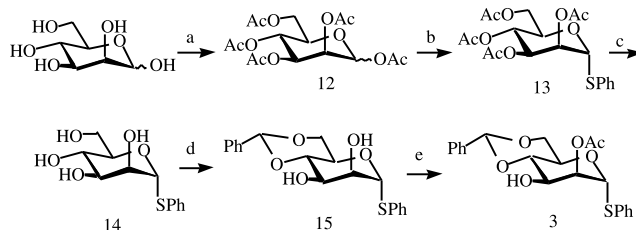
The blockwise synthesis of the tetrasaccharide **1**, depicted [Scheme 1](#), is based on the condensation of two disaccharidic blocks **7** and **9**.

The  $\alpha$ -selectivity of this glycosylation was controlled by the

participation of the acetyl group at position 2 of **7**. The disaccharidic donor unit **7** was prepared of an imidate **4** and a thiophenyl acceptor **3**. The acceptor unit **9** was prepared by debenzoylation of **8** obtained through condensation of thiophenyl mannoside **6** with the acceptor **5**. In these cases, the complete  $\alpha$  selectivity also relies on the neighboring group participation. The complete  $\alpha$ -selectivity of each glycosylation was confirmed by NMR: the coupling constants between anomeric carbon (C-1) and anomeric hydrogen (H-1) were around 175 Hz, as expected for  $\alpha$  anomers:<sup>19</sup> **7**  $J(C1, H-1) = 175$  Hz; **8**  $J(C1, H-1) = 172$  Hz and **10**  $J(C1, H-1) = 172$  Hz. It must be around 156 Hz for a  $\beta$  linkage. The tetrasaccharide **10** was deprotected in two



**Scheme 1.** Preparation of **1**. Reagents and conditions: (a) TMSOTf, CH<sub>2</sub>Cl<sub>2</sub>, -20 °C, 89%; (b) NIS, TfOH cat, CH<sub>2</sub>Cl<sub>2</sub>, -20 °C, 80%; (c) MeONa, MeOH, rt, 90%. (d) NIS, TfOH cat, CH<sub>2</sub>Cl<sub>2</sub>, -20 °C, 72%; (e) aq NaOH, THF, 60 °C, 82%; (f) H<sub>2</sub>, 10% Pd/C, MeOH, 83%.



**Scheme 2.** Preparation of **3**: Reagents and conditions: (a) Ac<sub>2</sub>O, pyr; (b) PhSH, BF<sub>3</sub>·Et<sub>2</sub>O, CH<sub>2</sub>Cl<sub>2</sub>, 76% two steps; (c) MeONa, MeOH; (d) PhCH(OMe)<sub>2</sub>, HBF<sub>4</sub>/Et<sub>2</sub>O, CH<sub>2</sub>Cl<sub>2</sub>; (e) CSA cat, CH<sub>3</sub>CH(OEt)<sub>3</sub>, then 80% aq AcOH, 75% two steps.

steps: saponification of ester functions by sodium hydroxide in hot aq THF, then hydrogenolysis of the benzyl groups to give **1**.

The synthesis started from four monosaccharidic blocks: **4**<sup>20</sup> and **6**<sup>21</sup> were prepared according literature procedure. Compound **3** was prepared by Lemieux's selective acetylation<sup>22</sup> of known<sup>23,24</sup> **15** (see Scheme 2). The preparation of **15** was optimized on a large scale (100 g) in particular, the monobenzyldienation of **14**<sup>25</sup> was improved using dichloromethane as a solvent instead of DMF (see Section 6).

Compound **5**<sup>26</sup> was prepared by NBS/triflic acid glycosylation of 2-*O*-benzoylated thioglycoside **6** of 8-methoxy carbonyloctanol **16** to give **17**. In this case, the use of NIS/triflic acid was ineffective. Compound **16**<sup>27</sup> was prepared<sup>28</sup> from methyl oleate (ozonolysis in dichloromethane then NaBH<sub>4</sub> reduction in methanol). It occurred that the initial preparation from azelaic acid was found much less convenient. The glycoside **17** was then debenzoylated to give the glycosyl acceptor **5** (Scheme 3).

The protected trisaccharide **18** (Scheme 4) was obtained by NIS/triflic acid glycosylation of **5** and **7** (75%). Treatment by sodium hydroxide in aq THF gave **19** and final hydrogenolysis of the benzyl groups gave **2** (Scheme 4).

### 3. Preparation of the glycoconjugates

Compounds **1** and **2** were then coupled with poly L-lysine hydrobromide (30–70 kD) using 1-(3-dimethylamino-propyl)-3-ethyl carbodiimide (EDC) at pH 4.6 (0.1 M aq morpholino ethyl sulfonate (MES) buffer) at rt to give **1-lys** and **2-lys**. A 6/1 weight ratio was used in order to have a 15% maximum sugar content in the glycosylated peptides. The yields were 50% after chromatography on sephadex G

25. The sugar content (ca. 10%) was estimated by 400 MHz <sup>1</sup>H NMR in D<sub>2</sub>O.

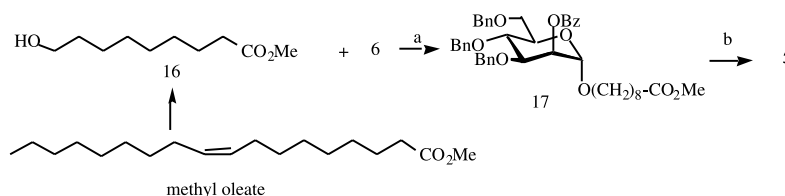
### 4. Evaluation of the polylysine conjugates: antibodies response in ELISA against synthetic oligomannosides

The series of experiments were conducted on sera from 90 patients with inflammatory bowel disease. Diagnosis of CD and UC was established by endoscopic, histologic and clinical criteria. There were 49 patients with Crohn's disease (19 males, 30 females, mean age 32 years), 41 patients with ulcerative colitis (22 males, 19 females, mean age: 33 years) and 46 healthy blood donors, as control group. For each patient, whole venous blood was collected and serum was separated by centrifugation for serological analyses (Figs. 2 and 3).

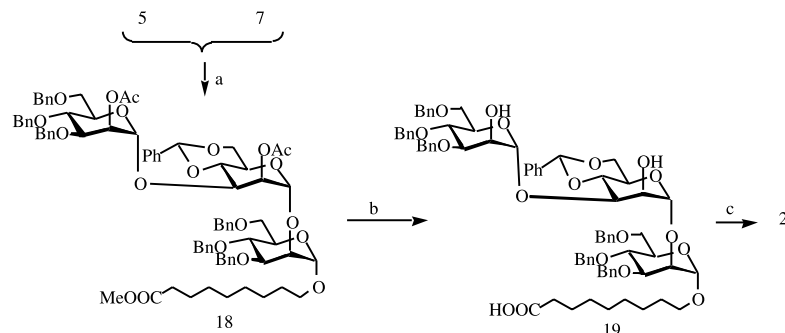
Figure 2 shows the results observed when immunoglobulins of patients with CD and UC or healthy controls reacting with synthetic trimannoside were quantified by ELISA. The mean value of trimannoside titers is 19.73 arbitrary units (a.u.) for CD, 3.70 for UC and 5.23 for control group.  $p=0.0006$  for CD versus UC and  $p=0.044$  for controls versus CD.

In the same way, on tetramannoside antigen (Fig. 3), the mean value of the antibodies titers for CD patients is twice higher than for UC patients (24.97 vs 12.67 respectively,  $p=0.0002$ ). For healthy subjects, the mean value is 9.38 a.u. and  $p<0.0001$  comparing to CD.

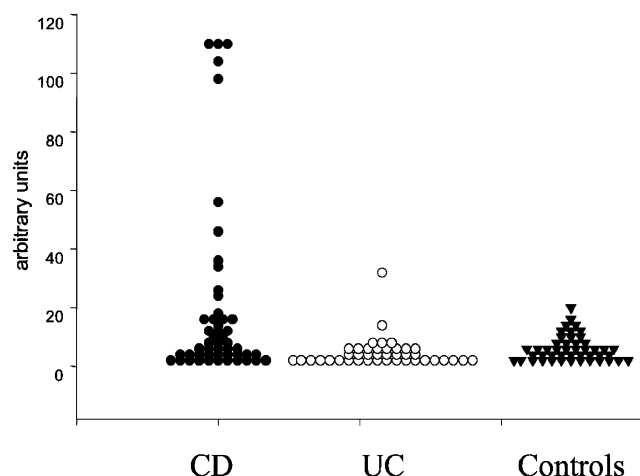
Both synthetic  $\alpha$ Man1-3 $\alpha$ Man1-2Man-Lys and  $\alpha$ Man1-3 $\alpha$ Man1-2 $\alpha$ Man1-2 Man-lys displayed a significantly stronger reactivity with sera of CD patient than with sera of UC patients. These results demonstrate that synthetic oligomannosides have the ability to discriminate between the two types of IBD pathologies.



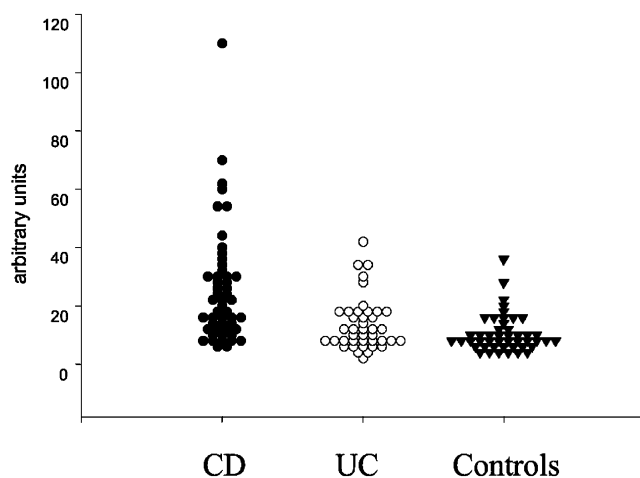
Scheme 3. Preparation of **5**: Reagents and conditions: (a) NBS, TfOH, CH<sub>2</sub>Cl<sub>2</sub>, -20 °C, 47%; (b) MeONa, MeOH, rt, 100%.



Scheme 4. Preparation of **2**: Reagents and conditions: (a) NIS, TfOH cat, CH<sub>2</sub>Cl<sub>2</sub>, -20 °C, 75%; (b) aq NaOH, THF, 60 °C, 73%; (c) H<sub>2</sub>, 10% Pd/C, MeOH, 95%.



**Figure 2.** Reactivity of patients against synthetic trimannoside **2-lys**: CD patients (black circle), UC patients (white circle) or controls (black triangle).



**Figure 3.** Reactivity of patients against synthetic tetramannoside **1-lys**: CD patients (black circle), UC patients (white circle) or controls (black triangle).

## 5. Conclusion

Following the development of the original ASCA test detection has been widely used for differential diagnosis among IBD patients. Other indications have been proposed such as disease monitoring and genetic counselling. More recently ASCA response and titers have been associated with CD phenotypes.<sup>29,30</sup> However, ASCA detection is not standardized and none of the numerous antigens currently used is chemically defined. This impairs both inter-laboratory reproducibility and basic analysis of the significance of the corresponding antibodies. The *S. cerevisiae* mannan is a complex repertoire of oligomannose epitopes varying among strains<sup>31</sup> and growth conditions.<sup>16, 29,32,33</sup> The major epitope supporting the specific response in CD patients versus UC patients has been identified previously by two independent research groups as corresponding to the structure  $\alpha$ -D-Man (1 $\rightarrow$ 3) [ $\alpha$ -D-Man(1 $\rightarrow$ 2)]<sub>n</sub>  $\alpha$ -D-Man ( $n=1$  or 2).<sup>7,6</sup> The aim of the study was to assess the potential of a test involving synthetic analogues of these structures as an antigen. The preliminary data gained in this study show that a signal specific for a

pathology was indeed detected. It therefore opens perspectives about development of highly standardized tests as well as providing tools to dissect the genetic basis of oligomannoside repertoire humoral recognition.<sup>34</sup>

## 6. Experimental

### 6.1. General procedures

All compounds were homogeneous by TLC analysis and had spectral properties consistent with their assigned structures. Melting points were determined in capillary tubes in a Büchi 510 apparatus, and are uncorrected. Optical rotations were measured with a Perkin-Elmer Model 241 digital polarimeter at  $22 \pm 3$  °C. Compound purity was checked by TLC on Silica gel 60 F<sub>254</sub> (E. Merck) with detection by charring with sulfuric acid. Column chromatography was performed on Silica gel 60 (E. Merck). <sup>1</sup>H NMR spectra were recorded with Bruker AM 250, AM 400 instruments. Mass spectroscopy analyses were performed on a Nermag R 10-10. Elemental analyses were performed by Service d'Analyse de Université Pierre et Marie Curie.

**6.1.1. Phenyl (2-*O*-acetyl-3,4,6-tri-*O*-benzyl- $\alpha$ -D-mannopyranosyl)-(1 $\rightarrow$ 3)-2-*O*-acetyl-4,6-*O*-benzylidene-1-thio- $\alpha$ -D-mannopyranoside (**7**).** To a stirred solution of  $4\alpha/\beta$  (731 mg, 1.15 mmol), **3** (420 mg, 1.04 mmol) and 4 Å molecular sieves (1.1 g) in anhydrous dichloromethane (12 mL) was added, at  $-20$  °C and under argon, TMSOTf (22  $\mu$ L, 0.115 mmol). After stirring for 1 h at  $-20$  °C, the mixture was neutralized with saturated sodium hydrogen carbonate and filtered through Celite. The organic layer was washed with brine, dried (MgSO<sub>4</sub>), filtered and concentrated. The residue was purified by flash chromatography (20% EtOAc in cyclohexane) to afford **7** (626 mg, 68%) as a white powder.  $[\alpha]_D +119$  ( $c$  0.55 in chloroform); mp: 58–59 °C (cyclohexane); <sup>1</sup>H NMR (400 MHz, CDCl<sub>3</sub>):  $\delta$  8.15–7.25 (m, 25H, arom.), 5.69 (s, 1H, benzylidene), 5.55 (dd, 1H,  $J_{2-1}=1.8$  Hz,  $J_{2-3}=2.7$  Hz, H-2D), 5.52 (dd, 1H,  $J_{2-1}=1.3$  Hz,  $J_{2-3}=3.4$  Hz, H-2C), 5.49 (d, 1H, H-1C), 5.34 (d, 1H, H-1D), 4.89 (d, 1H,  $J_{gem}=10.9$  Hz, CHPh), 4.77 (d, 1H,  $J_{gem}=12.2$  Hz, CHPh), 4.74 (d, 1H,  $J_{gem}=11.4$  Hz, CHPh), 4.56 (d, 1H,  $J_{gem}=12.2$  Hz, CHPh), 4.56 (d, 1H,  $J_{gem}=11.4$  Hz, CHPh), 4.54 (d, 1H,  $J_{gem}=10.9$  Hz, CHPh), 4.42 (ddd, 1H,  $J_{5-4}=9.8$  Hz,  $J_{5-6b}=4.9$  Hz,  $J_{5-6a}=10.3$  Hz, H-5C), 4.40 (dd, 1H,  $J_{3-4}=9.8$  Hz, H-3C), 4.30 (dd, 1H,  $J_{6b-6a}=10.3$  Hz, H-6Cb), 4.20 (t, 1H, H-4C), 3.97–3.87 (m, 4H, H-5D, H-4D, H-3D and H-6Ca), 3.86 (dd, 1H,  $J_{6b-6a}=12.0$  Hz,  $J_{6b-5}=3.9$  Hz, H-6Db), 3.78 (dd, 1H,  $J_{6a-5}=3.3$  Hz, H-6Da), 2.21 and 2.16 (2 s, 6H, 2 O=C=O-CH<sub>3</sub>); <sup>13</sup>C NMR (100 MHz):  $\delta$  170.1 and 169.7 (2 O=C=O-CH<sub>3</sub>), 138.4, 138.2, 137.9, 136.9 and 133.0 (5 C arom.), 132.0–125.9 (25 CH arom.), 101.3 (benzylidene), 98.8 (C-1D), 86.8 (C-1C), 78.9 (C-4C), 75.6, 74.1 and 72.1 (C-3D, C-4D and C-5D), 74.9 (CH<sub>2</sub>Ph), 73.4 (CH<sub>2</sub>Ph), 73.1 (C-2C), 71.7 (CH<sub>2</sub>Ph), 70.8 (C-3C), 68.6 (C-6D), 68.4 (C-2D), 68.2 (C-6C), 64.6 (C-5C), 21.0 and 20.8 (2 O=C=O-CH<sub>3</sub>); MS  $m/z$  (CI, NH<sub>3</sub>): 894.3 (M+NH<sub>4</sub>)<sup>+</sup>; Anal. Calcd for C<sub>50</sub>H<sub>52</sub>O<sub>12</sub>S (877.02): C 68.47, H 5.98. Found: C 68.36, H 6.15.

**6.1.2. 8-Methoxycarbonyloctyl (2-*O*-benzoyl-3,4,6-tri-*O*-benzyl- $\alpha$ -*D*-mannopyranosyl)-(1  $\rightarrow$  2)-3,4,6-tri-*O*-benzyl- $\alpha$ -*D*-mannopyranoside (8).** To a stirred solution of **6** (430 mg, 665  $\mu$ mol), **5** (412 mg, 665  $\mu$ mol) and 4 Å molecular sieves (1 g) in anhydrous dichloromethane (9 mL) were successively added, at  $-20^\circ\text{C}$  and under argon, NIS (306 mg, 1.33 mmol) and TfOH (11.7  $\mu$ L, 133  $\mu$ mol). After stirring for 30 min at  $-20^\circ\text{C}$ , the reaction mixture was diluted with dichloromethane, neutralized with saturated sodium hydrogen carbonate and filtered through Celite. The organic layer was washed with sodium thiosulfate, brine, dried ( $\text{MgSO}_4$ ), and concentrated. The residue was purified by flash chromatography (20% EtOAc in cyclohexane) to afford **8** (615 mg, 80%) as a colorless oil.  $[\alpha]_{\text{D}}^{25} + 5$  (c 0.6, chloroform);  $^1\text{H NMR}$  (400 MHz,  $\text{CDCl}_3$ ):  $\delta$  8.15–7.25 (m, 35H, arom.), 5.85 (dd, 1H,  $J_{2-1} = 1.8$  Hz,  $J_{2-3} = 3.3$  Hz, H-2B), 5.27 (d, 1H, H-1B), 4.96 (d, 1H,  $J_{1-2} = 1.6$  Hz, H-1A), 4.93 (d, 1H,  $J_{\text{gem}} = 10.7$  Hz, CHPh), 4.92 (d, 1H,  $J_{\text{gem}} = 10.9$  Hz, CHPh), 4.83 (d, 1H,  $J_{\text{gem}} = 11.1$  Hz, CHPh), 4.78 (d, 1H,  $J_{\text{gem}} = 12.0$  Hz, CHPh), 4.76 (s, 2H,  $\text{CH}_2\text{Ph}$ ), 4.74 (d, 1H,  $J_{\text{gem}} = 12.2$  Hz, CHPh), 4.63 (d, 1H,  $J_{\text{gem}} = 12.2$  Hz, CHPh), 4.62 (d, 1H,  $J_{\text{gem}} = 10.7$  Hz, CHPh), 4.58 (d, 1H,  $J_{\text{gem}} = 12.0$  Hz, CHPh), 4.57 (d, 1H,  $J_{\text{gem}} = 10.9$  Hz, CHPh), 4.51 (d, 1H,  $J_{\text{gem}} = 11.1$  Hz, CHPh), 4.19 (dd, 1H,  $J_{3-4} = 9.0$  Hz, H-3B), 4.12–4.09 (m, 2H, H-5B and H-4B), 4.07 (dd, 1H,  $J_{2-3} = 2.9$  Hz, H-2A), 4.00 (dd, 1H,  $J_{3-4} = 9.2$  Hz, H-3A), 3.94 (dd, 1H,  $J_{6b-6a} = 10.5$  Hz,  $J_{6b-5} = 3.0$  Hz, H-6Bb), 3.92 (t, 1H,  $J_{4-5} = 9.2$  Hz, H-4A), 3.85–3.77 (m, 4H, H-6A, H-6Ba and H-5A), 3.71 (s, 3H,  $-\text{CO}_2\text{CH}_3$ ), 3.67 (dt, 1H,  $J_{\text{gem}} = 9.5$  Hz,  $J_{\text{CH}-\text{CH}_2} = 6.7$  Hz,  $-\text{O}-\text{CH}-\text{CH}_2-$ ), 3.35 (dt, 1H,  $J_{\text{CH}-\text{CH}_2} = 6.7$  Hz,  $-\text{O}-\text{CH}-\text{CH}_2-$ ), 2.36 (t, 2H,  $J = 7.5$  Hz,  $-\text{CH}_2-\text{CO}_2\text{CH}_3$ ), 1.69–1.65, 1.57–1.54 and 1.35–1.33 (m, 12H,  $-(\text{CH}_2)_6-$ );  $^{13}\text{C NMR}$  (100 MHz):  $\delta$  174.2 ( $-\text{CO}_2\text{CH}_3$ ), 165.4 ( $-\text{O}-\text{C}=\text{O}$ ), 138.5, 138.4,  $2 \times 138.3$ , 138.2, 137.9 and 129.9 (7 C arom.), 133.0–127.3 (35 CH arom), 99.5 (C-1B), 98.6 (C-1A), 79.7 (C-3A), 78.0 (C-3B), 75.2 (C-2A), 75.1 ( $\text{CH}_2\text{Ph}$ ), 75.0 ( $\text{CH}_2\text{Ph}$ ), 74.6 (C-4B), 74.3 (C-4A), 73.3 ( $\text{CH}_2\text{Ph}$ ), 73.2 ( $\text{CH}_2\text{Ph}$ ), 72.1 ( $\text{CH}_2\text{Ph}$ ), 71.9 (C-5B), 71.7 (C-5A), 71.6 ( $\text{CH}_2\text{Ph}$ ), 69.2 (C-6A), 69.1 (C-6B), 68.9 (C-2B), 67.6 ( $-\text{O}-\text{CH}_2-$ ), 51.4 ( $-\text{CO}_2\text{CH}_3$ ), 34.0 ( $-\text{CH}_2-\text{CO}_2\text{CH}_3$ ), 29.3,  $2 \times 29.1$ , 29.0, 26.0 and 24.9 ( $-(\text{CH}_2)_6-$ ); MS  $m/z$  (CI,  $\text{NH}_3$ ): 1174.5 ( $\text{M} + \text{NH}_4$ ) $^+$ ; Anal. Calcd for  $\text{C}_{71}\text{H}_{80}\text{O}_{14}$  (1157.40): C 73.68, H 6.96. Found: C 73.61, H 7.11.

**6.1.3. 8-Methoxycarbonyloctyl (3,4,6-tri-*O*-benzyl- $\alpha$ -*D*-mannopyranosyl)-(1  $\rightarrow$  2)-3,4,6-tri-*O*-benzyl- $\alpha$ -*D*-mannopyranoside (9).** Sodium (11 mg) was added to a stirred solution of **8** (540 mg, 467  $\mu$ mol) in a mixture of methanol/dichloromethane (1:1, 5 mL). After stirring for 1 h, the reaction mixture was neutralized with Amberlite IR 120 ( $\text{H}^+$ ), filtered and concentrated. The residue was purified by flash chromatography (27% EtOAc in cyclohexane) to afford **9** (442 mg, 90%) as a colorless oil.  $[\alpha]_{\text{D}}^{25} + 34$  (c 0.7, chloroform);  $^1\text{H NMR}$  (400 MHz,  $\text{CDCl}_3$ ):  $\delta$  7.40–7.30 (m, 30H, arom.), 5.21 (d, 1H,  $J_{1-2} = 1.4$  Hz, H-1B), 4.95 (d, 1H,  $J_{1-2} = 1.7$  Hz, H-1A), 4.89 (d, 1H,  $J_{\text{gem}} = 10.6$  Hz, CHPh), 4.87 (d, 1H,  $J_{\text{gem}} = 10.9$  Hz, CHPh), 4.75 (d, 1H,  $J_{\text{gem}} = 12.2$  Hz, CHPh), 4.75 (d, 1H,  $J_{\text{gem}} = 11.6$  Hz, CHPh), 4.71 (d, 1H,  $J_{\text{gem}} = 11.6$  Hz, CHPh), 4.69 (d, 1H,  $J_{\text{gem}} = 12.1$  Hz, CHPh), 4.64 (d, 1H,  $J_{\text{gem}} = 11.4$  Hz, CHPh), 4.59 (d, 1H,  $J_{\text{gem}} = 10.6$  Hz, CHPh), 4.59 (d, 1H,  $J_{\text{gem}} = 12.2$  Hz, CHPh), 4.58 (d, 1H,  $J_{\text{gem}} = 11.4$  Hz, CHPh), 4.56 (d, 1H,  $J_{\text{gem}} =$

12.1 Hz, CHPh), 4.54 (d, 1H,  $J_{\text{gem}} = 10.9$  Hz, CHPh), 4.20–4.17 (m, 1H, H-2B), 4.08 (dd, 1H,  $J_{2-3} = 2.9$  Hz, H-2A), 4.03–3.99 (m, 1H, H-5B), 3.99 (dd, 1H,  $J_{3-4} = 9.3$  Hz, H-3A), 3.93 (dd, 1H,  $J_{3-4} = 9.1$  Hz, H-3B), 3.89 (t, 1H,  $J_{4-5} = 9.3$  Hz, H-4A), 3.86 (t, 1H,  $J_{4-5} = 9.1$  Hz, H-4B), 3.86 (dd, 1H,  $J_{6b-6a} = 11.1$  Hz,  $J_{6b-5} = 4.9$  Hz, H-6Ab), 3.82–3.75 (m, 4H, H-6Aa, H-6B and H-5A), 3.71 (s, 3H,  $-\text{CO}_2\text{CH}_3$ ), 3.65 (dt, 1H,  $J_{\text{gem}} = 9.5$  Hz,  $J_{\text{CH}-\text{CH}_2} = 6.8$  Hz,  $-\text{O}-\text{CH}-\text{CH}_2-$ ), 3.30 (dt, 1H,  $J_{\text{CH}-\text{CH}_2} = 6.8$  Hz,  $-\text{O}-\text{CH}-\text{CH}_2-$ ), 2.51 (d, 1H,  $J_{\text{OH}-2} = 1.9$  Hz, OH), 2.34 (t, 2H,  $J = 7.6$  Hz,  $-\text{CH}_2-\text{CO}_2\text{CH}_3$ ), 1.70–1.63, 1.56–1.49 and 1.37–1.27 (m, 12H,  $-(\text{CH}_2)_6-$ );  $^{13}\text{C NMR}$  (100 MHz):  $\delta$  174.3 ( $-\text{CO}_2\text{CH}_3$ ), 138.5,  $2 \times 138.3$ , 138.2, 138.1 and 137.9 (6 C arom.), 128.4–127.3 (30 CH arom), 101.0 (C-1B), 98.7 (C-1A), 79.9 (C-3B), 79.8 (C-3A), 75.1 ( $\text{CH}_2\text{Ph}$ ), 74.9 ( $\text{CH}_2\text{Ph}$ ), 74.9 (C-2A), 74.7 (C-4A), 74.3 (C-4B), 73.3 ( $\text{CH}_2\text{Ph}$ ), 73.2 ( $\text{CH}_2\text{Ph}$ ), 72.8 ( $\text{CH}_2\text{Ph}$ ), 72.0 ( $\text{CH}_2\text{Ph}$ ), 71.7 (C-5B), 71.6 (C-5A), 69.2 (C-6A), 69.0 (C-6B), 68.4 (C-2B), 67.6 ( $-\text{O}-\text{CH}_2-$ ), 51.4 ( $-\text{CO}_2\text{CH}_3$ ), 34.0 ( $-\text{CH}_2-\text{CO}_2\text{CH}_3$ ), 29.4, 29.2, 29.1, 29.0, 26.0 and 24.9 ( $-(\text{CH}_2)_6-$ ); MS  $m/z$  (CI,  $\text{NH}_3$ ): 1070.5 ( $\text{M} + \text{NH}_4$ ) $^+$ ; Anal. Calcd for  $\text{C}_{64}\text{H}_{76}\text{O}_{13}$  (1053.30): C 72.98, H 7.27. Found: C 72.89, H 7.43.

**6.1.4. 8-Methoxycarbonyloctyl (2-*O*-acetyl-3,4,6-tri-*O*-benzyl- $\alpha$ -*D*-mannopyranosyl)-(1  $\rightarrow$  3)-(2-*O*-acetyl-4,6-*O*-benzylidene- $\alpha$ -*D*-mannopyranosyl)-(1  $\rightarrow$  2)-(3,4,6-tri-*O*-benzyl- $\alpha$ -*D*-mannopyranosyl)-(1  $\rightarrow$  2)-3,4,6-tri-*O*-benzyl- $\alpha$ -*D*-mannopyranoside (10).** To a stirred solution of **7** (158 mg, 180  $\mu$ mol), **9** (186 mg, 180  $\mu$ mol) and 4 Å molecular sieves (500 mg) in anhydrous dichloromethane (5 mL) were successively added NIS (81 mg, 360  $\mu$ mol) and TfOH (4  $\mu$ L, 54  $\mu$ mol), at  $-20^\circ\text{C}$  and under argon. After stirring for 30 min at  $-20^\circ\text{C}$ , the reaction mixture was diluted with dichloromethane, neutralized with saturated sodium hydrogen carbonate and filtered through Celite. The organic layer was washed with sodium thiosulfate, brine, dried ( $\text{MgSO}_4$ ), and concentrated. The residue was purified by flash chromatography (17% EtOAc in cyclohexane) to afford **10** (236 mg, 72%) as a colorless oil.  $[\alpha]_{\text{D}}^{25} + 29$  (c 0.85 in chloroform);  $^1\text{H NMR}$  (400 MHz,  $\text{CDCl}_3$ ):  $\delta$  7.38–7.25 (m, 50H, arom.), 5.66 (s, 1H, benzylidene), 5.56 (dd, 1H,  $J_{2-1} = 1.5$  Hz,  $J_{2-3} = 3.0$  Hz, H-2D), 5.44 (dd, 1H,  $J_{2-1} = 1.3$  Hz,  $J_{2-3} = 3.5$  Hz, H-2C), 5.32 (se, 1H, H-1D), 5.20 (se, 1H, H-1B), 5.04 (se, 1H, H-1C), 4.94 (se, 1H, H-1A), 4.88 (d, 1H,  $J_{\text{gem}} = 10.6$  Hz, CHPh), 4.88 (d, 1H,  $J_{\text{gem}} = 10.7$  Hz, CHPh), 4.87 (d, 1H,  $J_{\text{gem}} = 10.9$  Hz, CHPh), 4.75 (d, 1H,  $J_{\text{gem}} = 12.4$  Hz, CHPh), 4.75 (d, 1H,  $J_{\text{gem}} = 11.2$  Hz, CHPh), 4.72 (s, 2H,  $\text{CH}_2\text{Ph}$ ), 4.67 (d, 1H,  $J_{\text{gem}} = 12.3$  Hz, CHPh), 4.67 (d, 1H,  $J_{\text{gem}} = 12.0$  Hz, CHPh), 4.62 (d, 1H,  $J_{\text{gem}} = 12.4$  Hz, CHPh), 4.61 (d, 1H,  $J_{\text{gem}} = 10.6$  Hz, CHPh), 4.60 (d, 1H,  $J_{\text{gem}} = 12.0$  Hz, CHPh), 4.58 (s, 2H,  $\text{CH}_2\text{Ph}$ ), 4.57 (d, 1H,  $J_{\text{gem}} = 11.2$  Hz, CHPh), 4.53 (d, 1H,  $J_{\text{gem}} = 10.9$  Hz, CHPh), 4.52 (d, 1H,  $J_{\text{gem}} = 10.7$  Hz, CHPh), 4.33 (d, 1H,  $J_{\text{gem}} = 12.3$  Hz, CHPh), 4.43 (dd, 1H,  $J_{3-4} = 9.3$  Hz, H-3C), 4.21 (dd, 1H,  $J_{6b-6a} = 10.4$  Hz,  $J_{6b-5} = 4.5$  Hz, H-6Cb), 4.14–4.12 (m, 1H, H-2B), 4.09 (t, 1H,  $J_{4-5} = 9.3$  Hz, H-4C), 4.07–4.04 (m, 1H, H-5C), 4.03 (t, 1H,  $J_{4-3} = J_{4-5} = 9.9$  Hz, H-4D), 4.01–4.00 (m, 1H, H-2A), 3.98–3.96 (m, 1H, H-3B), 3.93 (dd, 1H,  $J_{3-4} = 9.9$  Hz, H-3D), 3.88–3.85 (m, 1H, H-5D), 3.71 (s, 3H,  $-\text{CO}_2\text{CH}_3$ ), 3.62–3.59 (m, 1H, H-6Da), 3.60–3.56 (m, 1H,  $-\text{O}-\text{CH}-\text{CH}_2-$ ), 3.25 (dt, 1H,  $J_{\text{gem}} = 9.4$  Hz,  $J_{\text{CH}-\text{CH}_2} = 6.6$  Hz,  $-\text{O}-\text{CH}-\text{CH}_2-$ ), 2.34



(t, 2H,  $J_{\text{CH}_2\text{-CH}_2}=7.5$  Hz,  $-\text{CH}_2\text{-CO}_2\text{CH}_3$ ), 2.14 and 2.13 (2 s, 6H, 2 O-C=O-CH<sub>3</sub>), 1.70–1.62, 1.54–1.47 and 1.35–1.25 (m, 12H,  $-(\text{CH}_2)_6-$ ); <sup>13</sup>C NMR (100 MHz):  $\delta$  174.3 ( $-\text{CO}_2\text{CH}_3$ ), 170.1 and 169.5 (2 O-C=O-CH<sub>3</sub>), 138.6, 138.5, 2×138.3, 2×138.2, 2×138.1, 137.9 and 137.0 (10 C arom.), 128.7–125.9 (50 CH arom.), 101.2 (benzylidene), 100.6 (C-1B), <sup>1</sup>J<sub>C-H</sub>=171.3 Hz), 99.8 (C-1C), <sup>1</sup>J<sub>C-H</sub>=172.2 Hz), 98.8 (C-1D), <sup>1</sup>J<sub>C-H</sub>=174.0 Hz), 98.6 (C-1A), <sup>1</sup>J<sub>C-H</sub>=170.5 Hz), 79.3 (C-3B), 78.9 (C-4C), 77.7 (C-3D), 75.5 (C-2A), 75.4 (C-2B), 75.1 (CH<sub>2</sub>Ph), 75.0 (CH<sub>2</sub>Ph), 74.8 (CH<sub>2</sub>Ph), 73.9 (C-4D), 3×73.2 (3 CH<sub>2</sub>Ph), 72.1 (CH<sub>2</sub>Ph), 72.0 (CH<sub>2</sub>Ph), 72.0 (C-5D), 71.7 (CH<sub>2</sub>Ph), 71.4 (C-2C), 70.8 (C-3C), 68.1 (C-2D), 69.3, 69.2, 68.1 et 68.1 (4 C-6C), 67.6 ( $-\text{O}-\text{CH}_2-$ ), 51.4 ( $-\text{CO}_2\text{CH}_3$ ), 34.0 ( $-\text{CH}_2\text{-CO}_2\text{CH}_3$ ), 29.4, 29.2, 29.1, 29.0, 26.0 and 24.9 ( $-(\text{CH}_2)_6-$ ), 21.0 and 20.8 (2 O-C=O-CH<sub>3</sub>); MS *m/z* (CI, NH<sub>3</sub>): 1836.5 (M+NH<sub>4</sub>)<sup>+</sup>; Anal. Calcd for C<sub>108</sub>H<sub>122</sub>O<sub>25</sub> (1820.026): C 71.27, H 6.75. Found: C 71.08, H 6.94.

**6.1.5. 8-Carboxyloctyl (3,4,6-tri-*O*-benzyl- $\alpha$ -D-mannopyranosyl)-(1→3)-(4,6-*O*-benzylidene- $\alpha$ -D-mannopyranosyl)-(1→2)-(3,4,6-tri-*O*-benzyl- $\alpha$ -D-mannopyranosyl)-(1→2)-3,4,6-tri-*O*-benzyl- $\alpha$ -D-mannopyranoside (11).** A mixture of **10** (200 mg, 110  $\mu\text{mol}$ ), 0.1 N aq NaOH (5 mL) and THF (5 mL) was heated at reflux for 15 h, cooled to room temperature, acidified with of 1 N aq HCl and extracted with dichloromethane. The organic layer was dried (MgSO<sub>4</sub>), and concentrated. The residue was purified by flash chromatography (40% EtOAc in cyclohexane) to afford **11** (155 mg, 82%) as a colorless oil.  $[\alpha]_{\text{D}}^{25} +33$  (*c* 0.5 in chloroform); <sup>1</sup>H NMR (400 MHz, CDCl<sub>3</sub>):  $\delta$  7.50–7.25 (m, 50H, arom.), 5.60 (s, 1H, benzylidene), 5.21 (d, 1H,  $J_{1-2}=1.3$  Hz, H-1B), 5.16 (d, 1H,  $J_{1-2}=1.4$  Hz, H-1D), 5.12 (d, 1H,  $J_{1-2}=1.1$  Hz, H-1C), 4.97 (d, 1H,  $J_{1-2}=1.2$  Hz, H-1A), 4.42–4.41 (m, 1H, H-2C), 4.18–4.17 (m, 1H, H-2B), 4.08 (m, 1H, H-2D), 4.00 (dd, 1H,  $J_{2-3}=3.1$  Hz, H-2A), 3.60 (dt, 1H,  $J_{\text{gem}}=9.5$  Hz,  $J_{\text{CH-CH}_2}=6.5$  Hz,  $-\text{O}-\text{CH}-\text{CH}_2-$ ), 3.27 (dt, 1H,  $J_{\text{CH-CH}_2}=6.5$  Hz,  $-\text{O}-\text{CH}-\text{CH}_2-$ ), 2.35 (t, 2H,  $J=7.5$  Hz,  $-\text{CH}_2\text{-CO}_2\text{H}$ ), 1.70–1.60, 1.54–1.47 and 1.35–1.25 (m, 12H,  $-(\text{CH}_2)_6-$ ); <sup>13</sup>C NMR (100 MHz):  $\delta$  178.5 ( $-\text{CO}_2\text{H}$ ), 102.3 (C-1C), 101.7 (benzylidene), 100.9 (C-1B), 99.8 (C-1D), 98.5 (C-1A), 75.7 (C-2A), 74.8 (C-2B), 69.6 (C-2C), 68.5 (C-2D), 67.6 ( $-\text{O}-\text{CH}_2-$ ), 33.8 ( $-\text{CH}_2\text{-CO}_2\text{H}$ ), 29.3, 29.0, 28.9, 28.7, 25.9 and 24.5 ( $-(\text{CH}_2)_6-$ ); MS *m/z* (CI, NH<sub>3</sub>): 1738.9 (M+NH<sub>4</sub>)<sup>+</sup>; Anal. Calcd for C<sub>103</sub>H<sub>116</sub>O<sub>23</sub> (1722.059): C 71.84, H 6.79. Found: C 71.73, H 6.91.

**6.1.6. 8-Carboxyloctyl ( $\alpha$ -D-mannopyranosyl)-(1→3)-( $\alpha$ -D-mannopyranosyl)-(1→2)-( $\alpha$ -D-mannopyranosyl)-(1→2)- $\alpha$ -D-mannopyranoside (1).** A solution of **11** (100 mg, 58  $\mu\text{mol}$ ) in MeOH (5 mL) was stirred under H<sub>2</sub> atmosphere in the presence of 10% Pd/C (20 mg) for 1 h at room temperature, filtered through Celite and concentrated. The residue was partitioned between distilled water and dichloromethane. The aqueous layer was filtered (membrane 0.22  $\mu\text{m}$ ) and lyophilized to afford **1** (40 mg, 83%) as a white amorphous powder. <sup>1</sup>H NMR (400 MHz, D<sub>2</sub>O):  $\delta$  5.25 (d, 1H,  $J_{1-2}=1.2$  Hz, H-1B), 5.10 (d, 1H,  $J_{1-2}=1.3$  Hz, H-1D), 5.05 (d, 1H,  $J_{1-2}=0.8$  Hz, H-1A), 4.99 (d, 1H,  $J_{1-2}=1.4$  Hz, H-1C), 4.19 (dd, 1H,  $J_{2-3}=3.0$  Hz, H-2C), 4.07 (dd, 1H, H-2B), 4.03 (dd, 1H, H-2D), 3.90–3.88 (m, 1H, H-2A), 3.92 (dd, 1H,  $J_{3-4}=9.6$  Hz, H-3B),

3.91 (dd, 1H,  $J_{3-4}=9.4$  Hz, H-3C), 3.72–3.65 (m, 1H,  $-\text{O}-\text{CH}-\text{CH}_2-$ ), 3.49 (dt, 1H,  $J_{\text{gem}}=10.0$  Hz,  $J_{\text{CH-CH}_2}=6.2$  Hz,  $-\text{O}-\text{CH}-\text{CH}_2-$ ), 2.32 (t, 2H,  $J=7.4$  Hz,  $-\text{CH}_2\text{-CO}_2\text{H}$ ), 1.60–1.50 and 1.33–1.26 (m, 12H,  $-(\text{CH}_2)_6-$ ); <sup>13</sup>C NMR (100 MHz):  $\delta$  178.3 ( $-\text{CO}_2\text{H}$ ), 102.5 (C-1D), 102.4 (C-1C), 101.0 (C-1B), 98.3 (C-1A), 79.3 (C-2A), 78.9 (C-2B), 78.2 (C-3C), 3×73.6 and 73.0 (4 C-5), 70.6 (C-3D), 70.5 (C-3A), 70.3 (C-2D), 70.2 (C-3B), 69.9 (C-2C), 68.3 ( $-\text{O}-\text{CH}_2-$ ), 67.4, 2×67.2 and 66.5 (4 C-4), 2×61.4, 61.3 and 61.2 (4 C-6), 34.6 ( $-\text{CH}_2\text{-CO}_2\text{H}$ ), 28.7, 2×28.5, 28.4, 25.6 and 24.6 ( $-(\text{CH}_2)_6-$ ); MS *m/z* (HRMS): (M+Na)<sup>+</sup> calcd: 845.3267; found: 845.3295.

**6.1.7. Phenyl 2,3,4,6-tetra-*O*-acetyl-1-thio- $\alpha$ -D-mannopyranoside (13).** Acetic anhydride (345 mL) was added, at 0 °C to a solution of D-mannose (100 g, 556 mmol) in pyridine (500 mL). The solution was stirred overnight and concentrated. A solution of the residue in dichloromethane, was washed with 1 M aq HCl, aq sodium hydrogen carbonate, and water, dried (MgSO<sub>4</sub>) and concentrated to give **12**.

Thiophenol (85.5 mL, 1.5 equiv) and BF<sub>3</sub>Et<sub>2</sub>O (350 mL, 5 equiv) were added to a solution of compound **12** in anhydrous dichloromethane (500 mL). The solution was stirred overnight at rt, carefully neutralized by aq sodium hydrogen carbonate, dried (MgSO<sub>4</sub>) and concentrated. The residue was crystallized in diethyl ether/cyclohexane to give **13** (192.6 g, 76%). <sup>1</sup>H NMR (250 MHz, CDCl<sub>3</sub>):  $\delta$  7.33–7.13 (m, 5H, arom.), 5.35–5.33 (m, 2H, H-1 et H-2), 5.17–5.15 (m, 2H, H-3 et H-4), 4.39 (ddd, 1H,  $J_{5-6b}=5.2$  Hz,  $J_{5-6a}=2.3$  Hz et  $J_{5-4}=9.2$  Hz, H-5), 4.15 (dd, 1H,  $J_{6b-6a}=12.2$  Hz, H-6b), 3.94 (dd, 1H, H-6a), 2.00, 1.92, 1.89 et 1.86 (4 s, 12H, 4  $-\text{O}-\text{C}=\text{O}-\text{CH}_3$ ).

**6.1.8. Phenyl 4,6-*O*-benzylidene-1-thio- $\alpha$ -D-mannopyranoside (15).** Sodium (1.15 g, 0.1 M) was added to a solution of **13** (92.55 g, 203 mmol) in methanol (470 mL). The solution was stirred at rt overnight, neutralized with Amberlite IR 120 (H+) and concentrated and dried under vacuum on P<sub>2</sub>O<sub>5</sub> to give **14**.

Benzaldehyde dimethyl acetal (31.2 mL, 1.05 equiv) was added to suspension of **14** in anhydrous dichloromethane (1 L). HBF<sub>4</sub> (25.8 mL, 1.7 equiv, 50% in ethyl ether) was then added to the cooled solution (0 °C). The reaction mixture was stirred at rt overnight, neutralized (Et<sub>3</sub>N) and concentrated. The residue was crystallized in ethanol to give **15** (57.7 g, 79%) <sup>1</sup>H NMR (250 MHz, CD<sub>3</sub>OD):  $\delta$  7.57–7.27 (m, 10H, arom.), 5.62 (s, 1H, benzylidene), 5.49 (d, 1H,  $J_{1-2}=1.5$  Hz, H-1), 4.24 (m, 1H, H-5), 4.18 (d, 1H,  $J_{2-3}=3.5$  Hz, H-2), 4.13 (dd, 1H,  $J_{6b-6a}=10.0$  Hz et  $J_{6b-5}=5.0$  Hz, H-6b), 4.03 (t, 1H,  $J_{4-3}=J_{4-5}=10.0$  Hz, H-4), 3.95 (dd, 1H, H-3), 3.84 (t, 1H, H-6a).

**6.1.9. Phenyl 2-*O*-acetyl-4,6-*O*-benzylidene-1-thio- $\alpha$ -D-mannopyranoside (3).** Camphor sulfonic acid (292 mg, 1.2 mmol) was added to a stirred solution of **15** (2 g, 5.5 mmol) in triethyl orthoacetate (10 mL) at room temperature. After stirring for 30 min, aq acetic acid 80% (14.4 mL) was added to the cooled (0 °C) reaction mixture and then stirred 1 h at room temperature. Solvents were removed in vacuum and the residue was purified by flash

chromatography (33% EtOAc in cyclohexane) to afford **3** (1.67 g, 75%) as a white powder.  $[\alpha]_D +169$  (c 1.0, chloroform); mp: 157–158 °C (cyclohexane);  $^1\text{H NMR}$  (400 MHz,  $\text{CDCl}_3$ ):  $\delta$  7.56–7.30 (m, 10H, arom.), 5.66 (s, 1H, benzylidene), 5.52 (s, 1H, H-1), 5.51 (dd, 1H,  $J_{2-1}=1.3$  Hz,  $J_{2-3}=3.3$  Hz, H-2), 4.41 (ddd, 1H,  $J_{5-4}=9.7$  Hz,  $J_{5-6a}=10.3$  Hz,  $J_{5-6b}=4.9$  Hz, H-5), 4.29 (dd, 1H,  $J_{6b-6a}=10.3$  Hz, H-6b), 4.28–4.25 (m, 1H, H-3), 4.04 (t, 1H,  $J_{4-3}=9.7$  Hz, H-4), 3.89 (t, 1H, H-6a), 2.65 (d, 1H,  $J_{\text{OH}-3}=3.5$  Hz, OH), 2.21 (s, 3H,  $\text{O}-\text{C}=\text{O}-\text{CH}_3$ );  $^{13}\text{C NMR}$  (100 MHz):  $\delta$  170.3 ( $\text{O}-\text{C}=\text{O}-\text{CH}_3$ ), 136.9, 133.0 (2 C arom.), 132.0–126.2 (10 CH arom.), 102.2 (benzylidene), 86.8 (C-1), 79.0 (C-4), 73.5 (C-2), 68.3 (C-6), 67.7 (C-3), 64.5 (C-5A), 20.9 ( $\text{O}-\text{C}=\text{O}-\text{CH}_3$ ); MS  $m/z$  (CI): 403.2 (M+H) $^+$ ; Anal. Calcd for  $\text{C}_{21}\text{H}_{22}\text{O}_6\text{S}$  (402.46): C 62.67, H 5.51. Found: C 62.66, H 5.54.

**6.1.10. 8-Methoxycarbonyloctyl (2-O-acetyl-3,4,6-tri-O-benzyl- $\alpha$ -D-mannopyranosyl)-(1 $\rightarrow$ 3)-(2-O-acetyl-4,6-O-benzylidene- $\alpha$ -D-mannopyranosyl)-(1 $\rightarrow$ 2)-3,4,6-tri-O-benzyl- $\alpha$ -D-mannopyranoside (18).** Glycosylation of **7** (236 mg, 269  $\mu\text{mol}$ ) and **5** (165 mg, 269  $\mu\text{mol}$ ), as described for **10**, yielded **18** (275 mg, 75%) as a colorless oil.  $[\alpha]_D +26$  (c 0.4 in chloroform);  $^1\text{H NMR}$  (400 MHz,  $\text{CDCl}_3$ ):  $\delta$  7.54–7.21 (m, 35H, arom.), 5.67 (s, 1H, benzylidene), 5.54 (dd, 1H,  $J_{2-1}=1.8$  Hz,  $J_{2-3}=3.3$  Hz, H-2C), 5.45 (dd, 1H,  $J_{2-1}=1.5$  Hz,  $J_{2-3}=3.5$  Hz, H-2B), 5.31 (d, 1H,  $J_{1-2}=1.8$  Hz, H-1C), 5.11 (d, 1H, H-1B), 4.88 (d, 1H,  $J_{1-2}=1.9$  Hz, H-1A), 4.87 (d, 1H,  $J_{\text{gem}}=11.0$  Hz, CHPh), 4.85 (d, 1H,  $J_{\text{gem}}=10.7$  Hz, CHPh), 4.73 (d, 1H,  $J_{\text{gem}}=11.2$  Hz, CHPh), 4.71 (s, 2H,  $\text{CH}_2\text{Ph}$ ), 4.70 (d, 1H,  $J_{\text{gem}}=12.4$  Hz, CHPh), 4.67 (d, 1H,  $J_{\text{gem}}=12.2$  Hz, CHPh), 4.63 (d, 1H,  $J_{\text{gem}}=12.4$  Hz, CHPh), 4.54 (d, 1H,  $J_{\text{gem}}=11.2$  Hz, CHPh), 4.52 (d, 1H,  $J_{\text{gem}}=10.7$  Hz, CHPh), 4.50 (d, 1H,  $J_{\text{gem}}=11.0$  Hz, CHPh), 4.42 (dd, 1H,  $J_{3-4}=9.5$  Hz, H-3B), 4.34 (d, 1H,  $J_{\text{gem}}=12.2$  Hz, CHPh), 4.32 (dd, 1H,  $J_{6b-6a}=10.3$  Hz,  $J_{6b-5}=4.3$  Hz, H-6Bb), 4.09 (t, 1H,  $J_{4-5}=9.4$  Hz, H-4B), 4.07–3.99 (m, 3H, H-5B, H-2A and H-4C), 3.96 (dd, 1H,  $J_{3-2}=3.0$  Hz,  $J_{3-4}=8.5$  Hz, H-3A), 3.91 (dd, 1H,  $J_{3-4}=9.5$  Hz, H-3C), 3.89–3.75 (m, 7H, H-5C, H-6Ba, H-4A, H-5A, H-6Cb and H-6A), 3.70 (s, 3H,  $-\text{CO}_2\text{CH}_3$ ), 3.69 (dt, 1H,  $J_{\text{gem}}=9.6$  Hz,  $J_{\text{CH}-\text{CH}_2}=6.9$  Hz,  $-\text{O}-\text{CH}-\text{CH}_2-$ ), 3.58 (dd, 1H,  $J_{6a-6b}=10.8$  Hz,  $J_{6a-5}=1.6$  Hz, H-6Ca), 3.41 (dt, 1H,  $J_{\text{CH}-\text{CH}_2}=6.6$  Hz,  $-\text{O}-\text{CH}-\text{CH}_2-$ ), 2.34 (t, 2H,  $J=7.5$  Hz,  $\text{CH}_2-\text{CO}_2\text{CH}_3$ ), 2.12 and 2.09 (2 s, 6H, 2  $\text{O}-\text{C}=\text{O}-\text{CH}_3$ ), 1.67–1.64, 1.59–1.56 and 1.36–1.30 (m, 12H,  $-(\text{CH}_2)_6-$ );  $^{13}\text{C NMR}$  (100 MHz):  $\delta$  174.3 ( $-\text{CO}_2\text{CH}_3$ ), 170.1 and 169.5 (2  $-\text{O}-\text{C}=\text{O}-\text{CH}_3$ ), 138.6, 138.4, 138.3, 138.2, 138.1, 138.0 and 137.0 (7 C arom.), 128.8–125.9 (35 CH arom.), 101.4 (benzylidene), 99.9 (C-1B,  $^1J_{\text{C}-\text{H}}=173.1$  Hz), 98.8 (C-1C,  $^1J_{\text{C}-\text{H}}=174.0$  Hz), 98.6 (C-1A,  $^1J_{\text{C}-\text{H}}=169.0$  Hz), 79.7 (C-3A), 78.9 (C-4B), 77.7 (C-3C), 75.2 ( $\text{CH}_2\text{Ph}$ ),  $2\times 74.9$  (C-2A and C-4A), 74.9 ( $\text{CH}_2\text{Ph}$ ), 73.9 (C-4C),  $2\times 73.2$  (2  $\text{CH}_2\text{Ph}$ ), 72.1 ( $\text{CH}_2\text{Ph}$ ), 72.0 (C-5C), 71.7 (C-5A), 71.6 ( $\text{CH}_2\text{Ph}$ ), 71.4 (C-2B), 70.9 (C-3B), 69.1 (C-6A), 68.5 (C-2C), 68.4 (C-6B), 68.2 (C-6C), 67.6 ( $-\text{O}-\text{CH}_2-$ ), 63.9 (C-5B), 51.4 ( $-\text{CO}_2\text{CH}_3$ ), 34.0 ( $-\text{CH}_2-\text{CO}_2\text{CH}_3$ ), 29.4, 29.2, 29.1, 29.0, 26.0 and 24.9 ( $-(\text{CH}_2)_6-$ ), 21.0 and 20.8 (2  $-\text{O}-\text{C}=\text{O}-\text{CH}_3$ ); MS  $m/z$  (CI,  $\text{NH}_3$ ): 1404 (M+ $\text{NH}_4$ ) $^+$ ; Anal. Calcd for  $\text{C}_{81}\text{H}_{94}\text{O}_{20}$  (1387.636): C 70.11, H 6.82. Found: C 70.03, H 6.88.

**6.1.11. 8-Carboxyloctyl (3,4,6-tri-O-benzyl- $\alpha$ -D-mannopyranosyl)-(1 $\rightarrow$ 3)-(4,6-O-benzylidene- $\alpha$ -D-mannopyranosyl)-(1 $\rightarrow$ 2)-3,4,6-tri-O-benzyl- $\alpha$ -D-mannopyranoside (19).** Saponification of **18** (236 mg, 172  $\mu\text{mol}$ ) as described for **10**, yielded **19** (160 mg, 73%) as a colorless oil.  $[\alpha]_D +41$  (c 0.3 in chloroform);  $^1\text{H NMR}$  (400 MHz,  $\text{CDCl}_3$ ):  $\delta$  7.76–7.28 (m, 35H, arom.), 5.62 (s, 1H, benzylidene), 5.13 (d, 1H,  $J_{1-2}=1.3$  Hz, H-1C), 5.09 (se, 1H, H-1B), 4.90 (d, 1H,  $J_{\text{gem}}=10.3$  Hz, CHPh), 4.89 (se, 1H, H-1A), 4.85 (d, 1H,  $J_{\text{gem}}=11.0$  Hz, CHPh), 4.74 (d, 1H,  $J_{\text{gem}}=12.3$  Hz, CHPh), 4.73 (s, 2H,  $\text{CH}_2\text{Ph}$ ), 4.72 (s, 2H,  $\text{CH}_2\text{Ph}$ ), 4.64 (d, 1H,  $J_{\text{gem}}=12.3$  Hz, CHPh), 4.58 (d, 1H,  $J_{\text{gem}}=10.3$  Hz, CHPh), 4.55 (d, 1H,  $J_{\text{gem}}=11.2$  Hz, CHPh), 4.49 (d, 1H,  $J_{\text{gem}}=11.2$  Hz, CHPh), 4.48 (d, 1H,  $J_{\text{gem}}=11.0$  Hz, CHPh), 4.43–4.42 (m, 1H, H-2B), 4.29 (dd, 1H,  $J_{6b-6a}=10.2$  Hz,  $J_{6b-5}=4.6$  Hz, H-6Bb), 4.21–4.16 (m, 2H, H-3B and H-5C), 4.12 (t, 1H,  $J_{4-3}=J_{4-5}=9.6$  Hz, H-4B), 4.07–4.00 (m, 3H, H-2A, H-2C and H-5B), 3.98 (dd, 1H,  $J_{3-2}=2.9$  Hz,  $J_{3-4}=9.2$  Hz, H-3A), 3.97 (dd, 1H,  $J_{3-2}=3.2$  Hz,  $J_{3-4}=9.0$  Hz, H-3C), 3.91 (dd, 1H,  $J_{6a-5}=10.0$  Hz, H-6Ba), 3.89 (t, 1H,  $J_{4-3}=J_{4-5}=9.3$  Hz, H-4A), 3.84–3.74 (m, 3H, H-5A, H-6A and H-6Cb), 3.74–3.68 (m, 1H,  $-\text{O}-\text{CH}-\text{CH}_2-$ ), 3.68 (t, 1H,  $J_{4-5}=9.0$  Hz, H-4C), 3.55 (dd, 1H,  $J_{6a-6b}=9.8$  Hz,  $J_{6a-5}=7.6$  Hz, H-6Ca), 3.43 (dt, 1H,  $J_{\text{gem}}=9.6$  Hz,  $J_{\text{CH}-\text{CH}_2}=6.5$  Hz,  $-\text{O}-\text{CH}-\text{CH}_2-$ ), 2.37 (t, 2H,  $J=7.4$  Hz,  $-\text{CH}_2-\text{CO}_2\text{H}$ ), 1.70–1.64, 1.61–1.56 and 1.38–1.32 (m, 12H,  $-(\text{CH}_2)_6-$ );  $^{13}\text{C NMR}$  (100 MHz):  $\delta$  178.8 ( $-\text{CO}_2\text{H}$ ), 138.4, 138.2, 138.1, 137.8, 137.6, 137.5 and 137.2 (7 C arom.), 128.9–127.3 (35 CH arom.), 102.5 (C-1B), 101.8 (benzylidene), 99.8 (C-1C), 98.8 (C-1A), 79.7 (C-3A), 79.6 (C-3C), 77.3 (C-4B), 76.8 (C-3B), 75.2 ( $\text{CH}_2\text{Ph}$ ), 74.9 ( $\text{CH}_2\text{Ph}$ ), 74.8 (C-2A and C-4A), 74.5 (C-4C), 73.3 ( $\text{CH}_2\text{Ph}$ ), 73.2 ( $\text{CH}_2\text{Ph}$ ), 72.3 ( $\text{CH}_2\text{Ph}$ ), 72.0 ( $\text{CH}_2\text{Ph}$ ), 71.7 (C-5A), 71.5 (C-5C), 69.5 (C-2B), 69.1 (C-6A), 68.9 (C-6C), 68.7 (C-6B), 68.5 (C-2C), 67.6 ( $-\text{O}-\text{CH}_2-$ ), 64.1 (C-5B), 33.8 ( $-\text{CH}_2-\text{CO}_2\text{H}$ ), 29.3, 29.0, 28.9, 28.8, 25.9 and 24.6 ( $-(\text{CH}_2)_6-$ ); MS  $m/z$  (CI,  $\text{NH}_3$ ): 1306 (M+ $\text{NH}_4$ ) $^+$ ; Anal. Calcd for  $\text{C}_{76}\text{H}_{88}\text{O}_{18}$  (1289.534): C 70.78, H 6.87. Found: C 70.69, H 7.03.

**6.1.12. 8-Carboxyloctyl ( $\alpha$ -D-mannopyranosyl)-(1 $\rightarrow$ 3)-( $\alpha$ -D-mannopyranosyl)-(1 $\rightarrow$ 2)- $\alpha$ -D-mannopyranoside (2).** Hydrogenolysis of **19** (164 mg, 127.5  $\mu\text{mol}$ ), as described for **1**, yielded **2** (80 mg, 95%) as white amorphous powder.  $^1\text{H NMR}$  (400 MHz,  $\text{D}_2\text{O}$ ):  $\delta$  5.10 (s, 1H, H-1C), 5.04 (s, 1H, H-1A), 4.96 (s, 1H, H-1B), 4.19 (dd, 1H,  $J_{2-1}=1.3$  Hz,  $J_{2-3}=1.4$  Hz, H-2B), 4.03 (dd, 1H,  $J_{2-1}=1.5$  Hz,  $J_{2-3}=1.6$  Hz, H-2C), 3.93–3.88 (m, 2H, H-2A and H-3B), 3.86–3.82 (m, 2H, H-3A and H-3C), 3.72–3.65 (m, 1H,  $-\text{O}-\text{CH}-\text{CH}_2-$ ), 3.49 (dt, 1H,  $J_{\text{gem}}=10.4$  Hz,  $J_{\text{CH}-\text{CH}_2}=6.1$  Hz,  $-\text{O}-\text{CH}-\text{CH}_2-$ ), 2.32 (t, 2H,  $J=7.35$  Hz,  $\text{CH}_2-\text{CO}_2\text{CH}_3$ ), 1.60–1.52 and 1.34–1.25 (m, 12H,  $-(\text{CH}_2)_6-$ );  $^{13}\text{C NMR}$  (100 MHz):  $\delta$  180.2 ( $-\text{CO}_2\text{H}$ ), 102.6 (C-1B), 102.5 (C-1C), 98.3 (C-1A), 79.0 (C-2A), 78.1 (C-3B), 73.6, 73.6 and 73.0 (3 C-5), 70.6 (C-3C), 70.6 (C-3A), 70.3 (C-2C), 69.8 (C-2B), 68.3 ( $-\text{O}-\text{CH}_2-$ ),  $2\times 67.2$  and 66.6 (3 C-4), 61.4, 61.3 and 61.2 (3 C-6), 34.6 ( $-\text{CH}_2-\text{CO}_2\text{H}$ ), 28.7, 28.6, 28.5, 28.4, 25.6 and 24.8 ( $-(\text{CH}_2)_6-$ ); MS  $m/z$  (HRMS): (M+Na) $^+$  calcd: 683.2738; found: 683.2748.

## 6.2. Conjugation to poly L-lysine

The coupling buffer (0.1 M MES buffer, pH 4.6) was prepared as follow: 4-Morpholino ethane sulfonic acid

hydrate (Acros 17259, 1 g) was dissolved in water (50 mL), the pH was adjusted to 4.6 with conc aq NaOH.

Poly L-Lysine.hydrobromide (Sigma 2636, mol wt 30,000–70,000, 100 mg) was dissolved in MES buffer (4 mL). Compound **1** or **2** (20 mg) was dissolved in MES buffer (10 mL). The two solutions were mixed and EDC (Acros 17144, 50 mg) was added at rt. Another EDC portion (50 mg) was added after 5 h and the reaction mixture was stirred for 16 h at rt, and concentrated. The residue was purified on Sephadex G25 (column length 40 cm, diameter 2.6 cm) using water as eluent. The yields were 50%, the sugar content was 10% as evaluated by 400 MHz <sup>1</sup>H NMR.

### 6.3. Detection of antibodies against synthetic oligomannosides

Tetramannoside-poly-lysine **1-lys** and trimannoside-poly-lysine **2-lys** were used as antigens in an enzyme-linked immuno-sorbent assay. Plates were first coated overnight at room temperature with 200 µL of tetramannoside (**1-lys**) or trimannoside (**2-lys**) at a concentration of 10 µg/mL in phosphate buffered saline (PBS) 0.15 M. The day after, the plates were washed in PBS-Tween 0.2% and saturated with Glucose (5%) Bovine Serum Albumin (0.6%) in PBS 0.15 M. Patients sera were diluted 1:400 in a sample diluent (kit Platelia Candida Ab Biorad) and added to the plates for one hour at 37 °C. After three washing with TNT (Tris 0.05 M, NaCl 0.15 M, Tween 20 0.1%), a peroxidase-labeled goat antihuman immunoglobulin (G, A, M) (H and L chains) (Biorad, Marnes la Coquette, France) was used as conjugate. A color reaction was detected by incubation with 200 µL of tetramethylbenzidine solution for 30 min. Plates were read at 450 nm on a MRX2 (Dynex, France) automatic reader. A pool of sera from CD patients strongly reacting with both oligomannosides was selected for standardizing the tests and diluted from 1:100 to 1:6400. Each sample was tested in duplicate, the mean of the optical density in the two wells was calculated and reactivity of individual sera was expressed through the use of a program from Menarini laboratories as a percentage of the highest reactivity observed with the standard arbitrarily defined as 100%.

### 6.4. Statistical analysis

The statistical program used was Statview. The mean values were calculated on both antigen for CD and UC patients, and comparison between quantitative variables on the different groups was performed by the nonparametric Mann-Whitney test. Results were considered statistically significant when the two-side probability was less than 0.05.

### References and notes

- Sendid, B.; Quinton, J. F.; Charrier, G.; Goulet, O.; Cortot, A.; Grandbastien, B.; Poulain, D.; Colombel, J. F. *Am. J. Gastroenterol.* **1998**, *93*, 1306–1310.
- Main, J.; McKenzie, H.; Yeaman, G. R.; Kerr, M. A.; Robson, D.; Pennington, C. R.; Parratt, D. *BMJ* **1988**, *297*, 1105–1106.
- Quinton, J. F.; Sendid, B.; Reumaux, D.; Duthilleul, P.; Cortot, A.; Grandbastien, B.; Charrier, G.; Targan, S. R.; Colombel, J. F.; Poulain, D. *Gut* **1998**, *42*, 788–791.
- Lerner, A.; Shoenfeld, Y. *Eur. J. Gastroenterol. Hepatol.* **2002**, *14*, 103–105.
- Vermeire, S.; Joossens, S.; Peeters, M.; Monsuur, F.; Marien, G.; Bossuyt, X.; Groenen, P.; Vlietinck, R.; Rutgeerts, P. *Gastroenterology* **2001**, *120*, 827–833.
- Young, M.; Davies, M. J.; Bailey, D.; Gradwell, M. J.; Smestad-Paulsen, B.; Wold, J. K.; Barnes, R. M.; Hounsell, E. F. *Glycoconj. J.* **1998**, *15*, 815–822.
- Sendid, B.; Colombel, J. F.; Jacquinet, P. M.; Faille, C.; Fruit, J.; Cortot, A.; Lucidarme, D.; Camus, D.; Poulain, D. *Clin. Diagn. Lab. Immunol.* **1996**, *3*, 219–226.
- Kobayashi, H.; Shibata, N.; Watanabe, M.; Komido, M.; Hashimoto, N.; Suzuki, S. *Carbohydr. Res.* **1992**, *231*, 317–324.
- Okubo, Y.; Suzuki, S. *Carbohydr. Res.* **1978**, *62*, 135–141.
- Kobayashi, H.; Kojimahara, T.; Takahashi, K.; Takikawa, M.; Takahashi, S.; Shibata, N.; Suzuki, S. *Carbohydr. Res.* **1991**, *214*, 131–145.
- Shibata, N.; Fukasawa, S.; Kobayashi, H.; Tojo, M.; Yonezu, T.; Ambo, A.; Ohkubo, Y.; Suzuki, S. *Carbohydr. Res.* **1989**, *187*, 239–253.
- Tojo, M.; Shibata, N.; Ban, Y.; Suzuki, S. *Carbohydr. Res.* **1990**, *199*, 215–226.
- Kolarova, N.; Matulova, M.; Capek, P. *J. Carbohydr. Chem.* **1997**, 609.
- Parolis, L. A. S.; Parolis, H.; Kenne, L.; Meldal, M.; Bock, K. *Carbohydr. Res.* **1998**, *309*, 77–87.
- Sendid, B.; Poulain, D.; Colombel, J.-F.; Mallet, J.-M.; Chevalier, R.; Esnault, J.; Sinaÿ, P.; Dromer, F.; Improvici, L, patent PCT/FR00/03265.
- Dromer, F.; Chevalier, R.; Sendid, B.; Improvisi, L.; Jouault, T.; Robert, R.; Mallet, J. M.; Poulain, D. *Antimicrob. Agents Chemother.* **2002**, *46*, 3869–3876.
- Ogawa, T.; Yamamoto, H. *Carbohydr. Res.* **1985**, *137*, 79–88.
- Monsigny, M.; Roche, A.-C.; Midoux, P.; Mayer, R. *Adv. Drug Deliv. Rev.* **1994**, *14*, 1–24.
- Bock, K.; Lundt, T.; Pedersen, C. *Tetrahedron Lett.* **1973**, *13*, 1037–1040.
- Yamazaki, F.; Sato, S.; Nukada, T.; Ito, Y.; Ogawa, T. *Carbohydr. Res.* **1990**, *201*, 31–50.
- Zhang, Y.; Mallet, J.-M.; Sinaÿ, P. *Carbohydr. Res.* **1992**, *236*, 73–88.
- Lemieux, R. U.; Driguez, H. *J. Am. Chem. Soc.* **1975**, *97*, 4069–4075.
- Oshitari, T.; Kobayashi, S. *Tetrahedron Lett.* **1995**, *36*, 1089–1092.
- Franzik, H.; Meldal, M.; Paulsen, H.; Bock, K. *J. Chem. Soc., Perkin Trans. 1* **1995**, *22*, 2883.
- Maity, S.; Dutta, S.; Banerjee, A.; Achari, B.; Singh, M. *Tetrahedron* **1994**, *50*, 6965–6974.
- Tsui, D. S.; Gorin, P. A. J. *Carbohydr. Res.* **1986**, *156*, 1–8.
- Lemieux, R. U.; Bundle, D. R.; Baker, D. A. *J. Am. Chem. Soc.* **1975**, *97*, 4076–4083.
- Gerlach, H.; Künzler, P.; Oertle, K. *Helv. Chim. Acta* **1978**, *61*, 1226–1231.
- Klebl, F. H.; Bataille, F.; Berteau, C. R.; Herfarth, H.; Hofstadter, F.; Scholmerich, J.; Rogler, G. *Inflamm. Bowel Dis.* **2003**, *9*, 302–307.
- Mow, W. S.; Vasilias, E. A.; Lin, Y. C.; Fleshner, P. R.; Papadakis, K. A.; Taylor, K. D.; Landers, C. J.; Abreu-Martin,

- M. T.; Rotter, J. I.; Yang, H.; Targan, S. R. *Gastroenterology* **2004**, *126*, 414–424.
31. McKenzie, H.; Main, J.; Pennington, C. R.; Parratt, D. *Gut* **1990**, *31*, 536–538.
32. Aguilar-Uscanga, B.; Francois, J. M. *Lett. Appl. Microbiol.* **2003**, *37*, 268–274.
33. Klis, F. M.; Mol, P.; Hellingwerf, K.; Brul, S. *FEMS Microbiol Rev.* **2002**, *26*, 239–256.
34. Seibold, F.; Konrad, A.; Flogerzi, B.; Seibold-Schmid, B.; Arni, S.; Juliger, S.; Kun, J. F. *Gastroenterology* **2004**, *127*, 1076–1084.

# Ionic liquids for tetraarylporphyrin preparation

Satoshi Kitaoka, Kaoru Nobuoka and Yuichi Ishikawa\*

Department of Applied Chemistry, Faculty of Engineering, Oita University, 700 Dannoharu, Oita 870-1192, Japan

Received 5 April 2005; revised 11 May 2005; accepted 30 May 2005

Available online 17 June 2005

**Abstract**—In place of widely used dichloromethane, a series of ionic liquids, ILs, was employed as a reaction medium for the one-flask preparation of tetraarylporphyrins. The porphyrin yield in the IL was comparable to that in the dichloromethane, as long as both the water content and the fluidity were conditioned to be in the optimum state. When acidic IL, [C<sub>4</sub>-SAbim][CF<sub>3</sub>SO<sub>3</sub>] possessing a sulfonic acid moiety was used as the reaction medium, nothing but a black tarry by-product was obtained due to its strong acidity. However, using the acidic IL in a biphasic mode together with dichloromethane enabled porphyrins to form, even at a high reactant concentration. Furthermore, the phase-separated acidic IL was reusable for at least 10 times without any loss of catalytic activity.

© 2005 Elsevier Ltd. All rights reserved.

## 1. Introduction

Condensation of benzaldehyde with pyrrole followed by oxidation provides tetraphenylporphyrin (TPP),<sup>1</sup> *N*-confused tetraphenylporphyrin (NC-TPP)<sup>2</sup> and black tarry by-products. By using dichloromethane as the reaction medium, Lindsey demonstrated the top yields to be ca. 50 and 39% for TPP and NC-TPP, respectively.<sup>1</sup> Due to the excellent yield, mild condition and convenience, the Lindsey method has since been widely applied for the syntheses of porphyrins. This method, however, entails a heavy consumption of dichloromethane and results in a waste of acid catalysts. To obtain 1.0 g NC-TPP (1.0 g TPP), for instance, as much as 5 L (2 L) dichloromethane needs to be mounted in the reaction vessel under the optimal conditions when utilising the Lindsey method,<sup>1b</sup> which employs methanesulfonic acid, M-SA, as the acid catalyst. We thus, feel that the need, both to reduce the use of the halogenated solvent and to heighten the reusability of the acid catalyst without any loss of the productivity in the porphyrin preparation for the green chemistry.

ILs have been widely used for various reactions<sup>3</sup> such as olefin oligomerisation,<sup>4</sup> Heck reaction,<sup>5</sup> hydrogenation,<sup>6</sup> Friedel-Crafts reaction,<sup>7</sup> Diels–Alder reaction,<sup>8</sup> and several condensation reactions.<sup>9</sup> However, no such application of ILs for the preparation of porphyrins has been attempted before, except for that described in our previous brief report.<sup>10</sup> If the green property born from IL could be

applicable to the preparation of porphyrins, then it may be possible to undertake the Lindsey procedure without the need for the halogenated solvent. Our objective in this study, is to utilize ILs in the preparation of porphyrins with the aim of reducing and replacing the halogenated solvent.

In this study, we chose a series of ILs ranging from class I to class III, as shown in Chart 1, and we examined their behavior as a medium. The viscosity and water content of the ILs used are both well-known factors<sup>11</sup> that generally affect reactivity. Thus, these two factors in particular were carefully considered in the usage of IL as a single

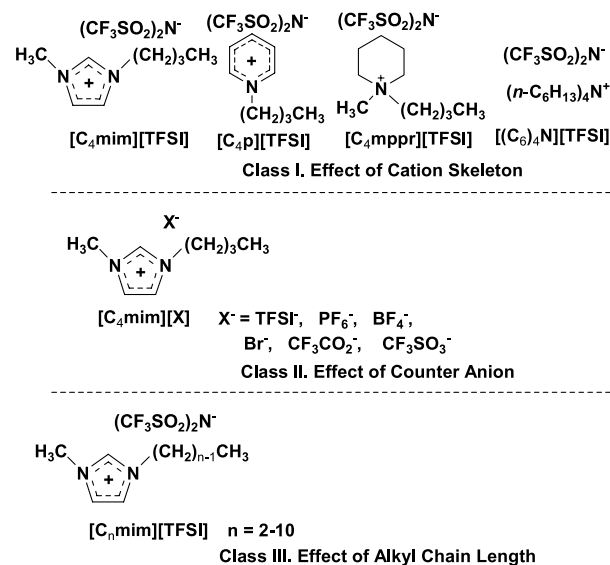


Chart 1.

**Keywords:** Ionic liquid; Porphyrin; Condensation.

\* Corresponding author. Tel./fax: +81 97 554 7907;

e-mail: [ishichem@cc.oita-u.ac.jp](mailto:ishichem@cc.oita-u.ac.jp)

homogeneous medium. As a result, the hydrophobic and moderately fluid [C<sub>4</sub>mim][TFSI] was the most appropriate medium for the porphyrin formation. However, reusing the IL as a homogeneous reaction medium was impractical due to the readily contamination of the produced by-product. In place of the homogeneous system, a biphasic mode reaction was devised for the porphyrin formation. In the case of the acidic IL, [C<sub>4</sub>-SAbim][CF<sub>3</sub>SO<sub>3</sub>] in Figure 1, its usage in the biphasic mode together with dichloromethane was studied with a view to reducing the amount of halogenated solvent and reusing the acid IL.

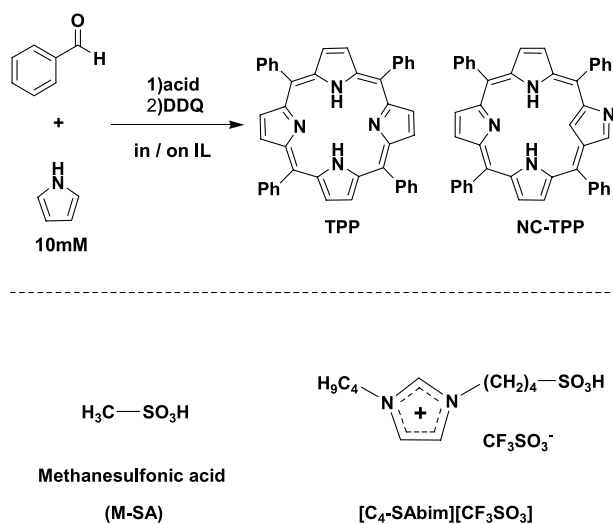


Figure 1. Acids and porphyrin formation.

## 2. Results and discussion

### 2.1. Classification of ILs

The IL derivatives employed in this study, can be categorized into four groups, as shown in Chart 1 and Figure 1. The relationship between the molecular structure of ILs and their role in the formation of porphyrin can be established in terms of this classification, and it is likely to be applicable to other condensation reactions.

In class I salts, five different cationic skeletons are selected in combination with the same anion, bis(trifluoromethylsulfonyl)imide [TFSI]<sup>−</sup> (Table 1). The cation structure effect on porphyrin formation will be discussed in terms of the viscosity. Class II, [C<sub>4</sub>mim][X], ILs are represented by the hydrophobicity/hydrophilicity of the corresponding

Table 1. The class I ILs used for porphyrin preparation

Solvent	Viscosity of IL/cP	H <sub>2</sub> O content of IL/wt%	Yield/%	
			TPP	NC-TPP
[C <sub>4</sub> mim][TFSI]	50.2	0.12	41	7
[C <sub>4</sub> p][TFSI]	63.5	0.08	33	4.2
[C <sub>4</sub> mppr][TFSI]	192	0.11	23	0
[(C <sub>6</sub> ) <sub>4</sub> N][TFSI]	573.4	0.12	2	0
CH <sub>2</sub> Cl <sub>2</sub>	—	—	8	38

[Pyrrole]=[aldehyde]=[DDQ]=10 mM, [M-SA]=7 mM, 22 °C, reaction time 30 min, yields were determined by HPLC analysis.

anions. [C<sub>*n*</sub>mim][TFSI]s are the class III salts in which alkyl chains of differing lengths are introduced in order to regulate both the viscosity and the hydrophobicity. Class IV imidazolium salt possesses a single sulfonic acid moiety, which acts as a catalyst, as shown in Figure 1.

Since, porphyrin formation begins with the condensation, the ILs used were kept as dry as possible by means of a thermostatic vacuum oven, 0.08 mmHg, 60 °C, over a period of 24 h. After an IL was taken out from the drying vacuum oven, the water content was immediately measured by a Karl-Fischer moisture titrator. Although, all the ILs were dried under the same conditions, the water content varied greatly according to the salt structure, as shown in Table 2.

Table 2. Porphyrin preparation in class II ILs with various anions

Solvent	Viscosity of IL/cP	H <sub>2</sub> O content of IL/wt%	Yield/%	
			TPP	NC-TPP
[C <sub>4</sub> mim][TFSI]	50.2	0.12	41	7
[C <sub>4</sub> mim][PF <sub>6</sub> ]	289	0.22	11	4
[C <sub>4</sub> mim][BF <sub>4</sub> ]	92.2	1.09	0.8	0.3
[C <sub>4</sub> mim][Br]	1462	2.45	0.1	0
[C <sub>4</sub> mim][CF <sub>3</sub> CO <sub>2</sub> ]	71.2	2.1	0.5	0
[C <sub>4</sub> mim][CF <sub>3</sub> SO <sub>3</sub> ]	93.2	1.62	0.3	0.7

[Pyrrole]=[aldehyde]=[DDQ]=10 mM, [M-SA]=7 mM, 22 °C, reaction time 30 min, yields were determined by HPLC analysis.

### 2.2. Screening to cationic skeletons/class I ILs

Five cationic structures, imidazolium, pyridinium, piperidinium, and ammonium were tested to see if their solvent properties were suitable for porphyrin formation. Table 1 shows that all the ILs except for the *n*-hexylammonium bis(trifluoromethylsulfonyl)imide [(C<sub>6</sub>)<sub>4</sub>N][TFSI] can be used as the reaction medium in place of dichloromethane, except with regard to the selectivity for *N*-confusion.<sup>12</sup> The ammonium [(C<sub>6</sub>)<sub>4</sub>N][TFSI], however, did not work as a medium for porphyrin formation at all. While there is no appreciable difference in water content, the viscosity is reflected by the cationic skeleton structure. Since the most viscous, 573.4 cP, ammonium [(C<sub>6</sub>)<sub>4</sub>N][TFSI] and the most fluid, 50.2 cP, imidazolium [C<sub>4</sub>mim][TFSI] show the worst and the best yields, respectively, viscosity can be assumed to be one of the keys to regulating porphyrin formation.

### 2.3. Screening of counter anions/class II ILs

The counter anion on the 1-butyl-3-methylimidazolium, C<sub>4</sub>mim, divides the class II salts into water-soluble and water phase-separable groups. When the former, [C<sub>4</sub>mim][BF<sub>4</sub>], [C<sub>4</sub>mim][Br], [C<sub>4</sub>mim][CF<sub>3</sub>CO<sub>2</sub>], and [C<sub>4</sub>mim][CF<sub>3</sub>SO<sub>3</sub>], were used as the solvent, porphyrins were obtained at less than 1% in total yield. On the other hand, the latter, [C<sub>4</sub>mim][TFSI] and [C<sub>4</sub>mim][PF<sub>6</sub>], produced porphyrins at 49 and 15% in total yield, respectively. The gap in the yield between [C<sub>4</sub>mim][TFSI] and [C<sub>4</sub>mim][PF<sub>6</sub>] would seem to originate from their difference in viscosity. The amount of water remaining in the former ILs is five to

20 times more than that in the latter ILs. Water content of more than 1 wt% in the water-soluble IL would perturb the condensation between pyrrole and benzaldehyde, resulting in a poor porphyrin yield.

#### 2.4. Intended addition of water

To exemplify that the contained water disturbs the condensation reaction, a certain amount of water was intentionally added to the [C<sub>4</sub>mim][TFSI]. Five [C<sub>4</sub>mim][TFSI]s possessing a different water content were prepared for porphyrin formation. Figure 2 shows the relation between porphyrin yield and water content, in addition to the change in viscosity. When the water content in [C<sub>4</sub>mim][TFSI] was increased, the yields of both TPP and NC-TPP deteriorated in accordance with decreasing viscosity, from 50 cP down to 33 cP. It is obvious that porphyrins are noticeably less obtainable if the amount of water which remains exceeds 1.0 wt%. In general, increasing fluidity of a viscous medium results in facilitating a reaction. Nevertheless, Figure 2 demonstrates the opposite result as to the relation between yield and viscosity. The effect of the disadvantage due to the remaining water outweighs the benefit stemming from the fluidity increase, as long as the water content ranges below 50 cP.

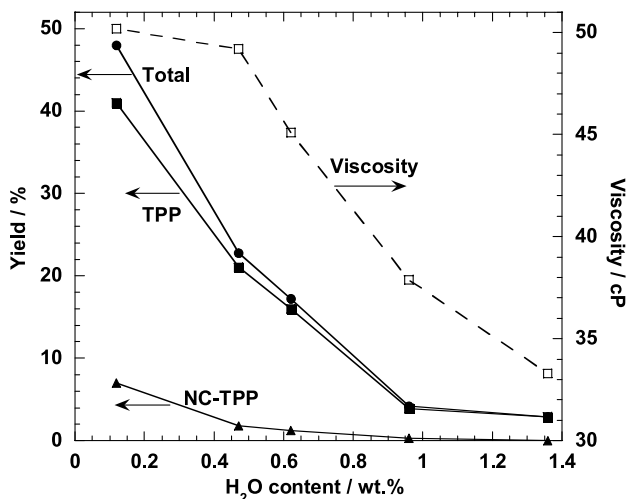


Figure 2. Porphyrin preparation in [C<sub>4</sub>mim][TFSI] with various amounts of water content.

#### 2.5. Alkyl chain length effect in class III, C<sub>n</sub>mims

In the case, where the viscosity is below 50 cP, as shown in Figure 2, how much water exists is much more important than how low the viscosity is. To examine the influence of a viscosity of more than 50 cP on the yield of porphyrins, a set of [C<sub>n</sub>mim][TFSI]s,  $n = 2, 3, 4, 5, 6, 7, 8, 9,$  and 10, was used for the condensation reaction.

Figure 3 compares the viscosity with the contained water in terms of the alkyl chain length, and shows the relation between porphyrin yield and these two features. It can be confirmed<sup>13</sup> that the viscosity varies with the alkyl chain length, that is, as the alkyl chain becomes longer, the salt

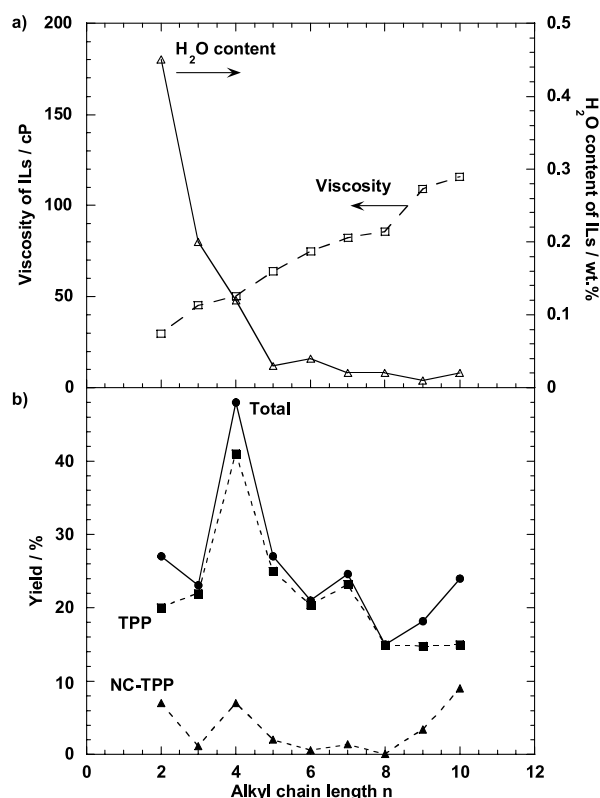


Figure 3. The relationship between alkyl chain length  $n$  ( $n = 2-10$ ) of [C<sub>n</sub>mim][TFSI] and porphyrin yield, viscosity, and water content; (a) viscosity and water content of the class III ILs, (b) porphyrin productivity in the class III ILs.

becomes more viscous and more hydrophobic. The viscosity for [C<sub>10</sub>mim][TFSI] and for [C<sub>2</sub>mim][TFSI] is more than double and nearly half of that for [C<sub>4</sub>mim][TFSI], respectively. In contrast, the amount of water, which remains shows the opposite tendency with regard to alkyl chain length. As long as the water, which remains in the ILs with a longer alkyl than butyl chain length (from [C<sub>5</sub>-mim][TFSI] to [C<sub>10</sub>mim][TFSI]) is less than one-sixth that in the [C<sub>4</sub>mim][TFSI], then the [C<sub>2</sub>mim][TFSI] and [C<sub>3</sub>-mim][TFSI] contain more water than the [C<sub>4</sub>mim][TFSI] does. In particular, the amount of water remaining in the [C<sub>2</sub>mim][TFSI] is four times that in the [C<sub>4</sub>mim][TFSI].

As shown in Figure 3b, all the ILs used, except for [C<sub>4</sub>mim][TFSI], provided TPP in yields of  $20 \pm 5\%$ . Only the [C<sub>4</sub>mim][TFSI] produced twice as much TPP as the other ILs with an alkyl chain length shorter or longer than the butyl chain length. Increasing the alkyl chain length makes an IL, which is viscous enough to limit diffusion of the substrates in return for reducing the amount of remaining water, due to increased hydrophobicity. When the viscosity ranges beyond 50 cP, the former as to the diffusing factor governs the porphyrin formation. On the other hand, in the case of [C<sub>2</sub>mim][TFSI] and [C<sub>3</sub>-mim][TFSI], the large amount of remaining water is the leading reason for an impaired reaction. This is why butyl [C<sub>4</sub>mim][TFSI] shows the maximum TPP productivity against the alkyl chain length. In other words, the butyl chain is an optimal point of length in the trade-off relation between the remaining water and the viscosity.<sup>14</sup>

## 2.6. [C<sub>4</sub>-SAbim][CF<sub>3</sub>SO<sub>3</sub>] and M-SA

Davis et al. reported<sup>15</sup> [C<sub>4</sub>-SAbim][CF<sub>3</sub>SO<sub>3</sub>] catalyzed esterification,<sup>15</sup> and Friedel-Crafts alkylation.<sup>16</sup> Since, the acid moiety in [C<sub>4</sub>-SAbim][CF<sub>3</sub>SO<sub>3</sub>] also seems to catalyze porphyrin formation, the acidic IL was compared with the typical acid catalyst, M-SA. Entries 2–5 in Table 3 summarize the results. The acidity of neat [C<sub>4</sub>-SAbim][CF<sub>3</sub>SO<sub>3</sub>] is too strong to form the aromatic rings, as shown in entry 2. Hence, the acidic IL is diluted with the widely used [C<sub>4</sub>mim][TFSI] and tested as entry 3. Since, the acid concentration generally affects porphyrin formation, as shown in entries 4 and 5, the concentration of [C<sub>4</sub>-SAbim][CF<sub>3</sub>SO<sub>3</sub>] in [C<sub>4</sub>mim][TFSI] was set to be the same as that of 7 mM M-SA. Entry 3 shows that the [C<sub>4</sub>mim][TFSI] solution of [C<sub>4</sub>-SAbim][CF<sub>3</sub>SO<sub>3</sub>] produced TPP and NC-TPP in yields of 46 and 5%, respectively, without the addition of any acid catalyst. The total yield, 51% in entry 3, is larger than that of the M-SA catalyzed reaction, 44% in entry 5. This fact indicates that similar to M-SA, the diluted [C<sub>4</sub>-SAbim][CF<sub>3</sub>SO<sub>3</sub>] with [C<sub>4</sub>mim][TFSI] acts as an effective catalyst to form a porphyrin ring, apart from the selectivity for TPP and NC-TPP.<sup>12</sup>

It is true that the hydrophobic and moderately fluid [C<sub>4</sub>mim][TFSI] containing [C<sub>4</sub>-SAbim][CF<sub>3</sub>SO<sub>3</sub>] allows us to conduct the porphyrin synthesis without using the halogenated solvent in excellent yield, as well as the hydrophobic IL possessing M-SA as shown in Table 2. However, both of the two acidic systems utilizing the [C<sub>4</sub>mim][TFSI] have a serious problem when using them as a homogeneous reaction medium. It is the contamination stemmed from the tarry by-products with which the formation of the porphyrin ring is impaired as described below. To avoid the fatal defect, we have devised the following biphasic mode reaction.

## 2.7. Biphasic reaction of acidic IL and dichloromethane

As confirmed above, well-devised ILs are employable as the reaction medium for porphyrin formation in place of the widely used halogenated solvent. However, the ILs used are unlikely to be reused for the reaction due to the difficulty in

removing the dissolved black tarry by-products from the ILs. Unlike the porphyrins, the tar, which emerged from the oxidation step could not be taken away from the non-volatile IL by extraction with a halogenated solvent. Thus, the difficulties entailed in reusing of the costly ILs become a serious problem for green synthesis. To avoid the inherent demerit arising from the tar contamination without losing any productivity with regard to porphyrins, we devised a biphasic reaction arising from the interface between dichloromethane and the acidic IL.

Prior to monitoring the reaction, we confirmed the miscibility between dichloromethane and [C<sub>4</sub>mim][TFSI] containing the acid catalyst, M-SA or [C<sub>4</sub>-SAbim][CF<sub>3</sub>SO<sub>3</sub>]. Mixing [C<sub>4</sub>mim][TFSI] with dichloromethane, at broad volume ratio ranging from 1/20 to 20/1, shows a single phase, not the phase-separated situation regardless of the added acid. Furthermore, the tested imidazolium ILs shown in Table 2 all are well miscible with dichloromethane regardless of the counter anion. As opposed to these homogeneous situations, undiluted [C<sub>4</sub>-SAbim][CF<sub>3</sub>SO<sub>3</sub>] itself is fortunately immiscible with dichloromethane as shown in Figure 4, thereby enabling us to perform a biphasic mode reaction. The phase-separated situation not only permits us to readily recycle the ILs, it might also suppress the dissolution of the [C<sub>4</sub>-SAbim][CF<sub>3</sub>SO<sub>3</sub>] into dichloromethane. The superior immiscibility of the acidic IL would originate from the hydrophilic, that is, oleophobic sulfonic acid moiety.

Dichloromethane (10 mL) was placed on the [C<sub>4</sub>-SAbim][CF<sub>3</sub>SO<sub>3</sub>] (3 mL) in a test tube, having formed the interface ( $\phi$  1.6 mm, 200 mm<sup>2</sup>) had been formed at 22 °C. This biphasic solution was allowed to stand for 10 min. Adding neat pyrrole (14.5 mM) and benzaldehyde (14.5 mM) onto the upper solution immediately resulted in the appearance of color in the dichloromethane phase. The color stemming from the precursors of the porphyrins (porphyrinogen) heightened over time, as shown in Figure 4. Unlike the dichloromethane solution, the IL phase was not colored at all during the reaction period. After 20 min, the dark brown dichloromethane solution was separated from the IL phase and then oxidized by the addition of powdered DDQ

**Table 3.** Porphyrin preparation utilizing [C<sub>4</sub>-SAbim][CF<sub>3</sub>SO<sub>3</sub>]<sup>a</sup> at a low reactant concentration

Entry	Acid/mm <sup>2</sup> or mM	Solvent	[Reactant]/mM	Time <sup>b</sup> /min	Yield/%	
					TPP	NC-TPP
1 <sup>a</sup>	Interface 200 mm <sup>2</sup> at [C <sub>4</sub> -SAbim] [CF <sub>3</sub> SO <sub>3</sub> ]/CH <sub>2</sub> Cl <sub>2</sub>	CH <sub>2</sub> Cl <sub>2</sub>	14.5	20	43	10
2 <sup>c</sup>	[C <sub>4</sub> -SAbim][CF <sub>3</sub> SO <sub>3</sub> ] neat	[C <sub>4</sub> -SAbim][CF <sub>3</sub> SO <sub>3</sub> ] <sup>d</sup>	10	5	0	0
3 <sup>c</sup>	[C <sub>4</sub> -SAbim][CF <sub>3</sub> SO <sub>3</sub> ] 7	[C <sub>4</sub> mim][TFSI]	10	30	46	5
4 <sup>e</sup>	M-SA 0.32	CH <sub>2</sub> Cl <sub>2</sub>	10	480	43	10
5 <sup>e</sup>	M-SA 7	CH <sub>2</sub> Cl <sub>2</sub>	10	30	5	39

Reaction condition; 22 °C, [aldehyde]=[pyrrole], [oxidant]=[reactant].

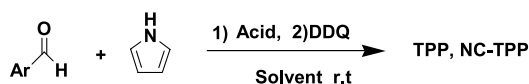
<sup>a</sup> This work; yields were determined after recrystallization.

<sup>b</sup> Condensation time.

<sup>c</sup> This work; yields were determined by HPLC analysis.

<sup>d</sup> The viscosity is 3185 cP and the water content is 1.85 wt%.

<sup>e</sup> Lindsey Method; data from Ref. 1, yields were determined by HPLC analysis without recrystallization.





pyrrole (145mM)	-	+	+	+	+
aldehyde (145mM)	-	-	+	+	+
reaction time (min.)	-	-	5	10	20

**Figure 4.** Photograph showing colour change due to condensation reaction at the interface between  $\text{CH}_2\text{Cl}_2$  and acidic IL. Room temperature +/–: denotes the presence/absence, respectively.

(342 mg, 14.5 mM) at 22 °C. Triethylamine (100  $\mu\text{L}$ ) was added to the black solution which formed, in order to quench the dissolved acid. Subsequent treatments for the isolation of porphyrins were conducted according to the literature.<sup>1</sup> Recrystallized TPP and NC-TPP were obtained at yields of 43 and 10%, respectively (Table 3, entry 1). Table 3 compares the present biphasic reaction with the Lindsey method<sup>1</sup> using M-SA in dichloromethane. It is obvious that the biphasic procedure is broadly comparable in yield to the single homogeneous reaction (entries 1, 4, and 5), regardless of the selectivity<sup>12</sup> for the ordinal and *N*-confused porphyrins.

To minimize the amount of dichloromethane solvent, we examined the formation of porphyrins at a 10-fold higher reactant concentration, 145 mM, on the interface (Table 4, entry 1). The isolated yield of TPP at 145 mM on the acidic IL interface was as little as 16% less than that at 14.5 mM (Table 3, entry 1), but two to eleven times more than that at 100 mM of the homogeneous condensation employing M-SA. This fact means that, in spite of some loss in efficiency, the interfacial reaction using  $[\text{C}_4\text{-SAbim}][\text{CF}_3\text{SO}_3]$  is suitable for the case of a high reactant concentration, when compared to the homogeneous reaction. Separating the acid catalysis from the reaction medium is beneficial for increasing the production of porphyrins, particularly at a

high concentration. This knowledge leads to a reduction in the amount of halogenated solvent, which needs to be used.

## 2.8. Need of interface

Increasing the concentration of the M-SA and/or the reactants generally results in a low yield of porphyrins due to oligomer formation,<sup>1a</sup> as shown in Table 4. When dichloromethane solution, which was saturated or partially dissolved with  $[\text{C}_4\text{-SAbim}][\text{CF}_3\text{SO}_3]$  (Table 4, entries 7 and 8) was applied as a homogeneous single phase, low yields, 7–11% TPP and 2–4% NC-TPP, were observed similar to the dichloromethane solution of M-SA (Table 4, entries 9 and 10). These facts indicate that the presence of the acidic IL phase through the interface helps facilitate the condensation in the dichloromethane phase, even at a high reactant concentration.

## 2.9. Reusing acidic IL at a high reactant concentration

In addition to the above benefit, another advantage, which results from devising the separated phase of the  $[\text{C}_4\text{-SAbim}][\text{CF}_3\text{SO}_3]$  is its reusability. Table 5 shows the relation between the repeated use of  $[\text{C}_4\text{-SAbim}][\text{CF}_3\text{SO}_3]$  and the preparation of TPP, NC-TPP, tetra-*p*-tolylporphyrin (TTP), and *N*-confused tetra-*p*-tolylporphyrin (NC-TTP). To reduce the amount of dichloromethane as much as possible, the reactant concentration was set to be 145 mM, which was more than 10 times that which had been explored for the optimum concentration in the Lindsey method.<sup>1</sup> After the condensation, the upper dichloromethane phase was removed from the acidic IL phase. Fresh dichloromethane solution of the reactants was added to the remaining  $[\text{C}_4\text{-SAbim}][\text{CF}_3\text{SO}_3]$ , being as a single phase in the test tube, in order to start the biphasic reaction again. On the other hand, powdered DDQ was added to the removed dichloromethane solution and the porphyrins, which formed were isolated. The area of the interface was ca. 200  $\text{mm}^2$ . This procedure was repeated 10 times at 22 °C, without supplying any acid catalysts.

In addition, the manner in which vigorous shaking of the phase-separated system affects the reaction was estimated

**Table 4.**  $[\text{C}_4\text{-SAbim}][\text{CF}_3\text{SO}_3]/\text{CH}_2\text{Cl}_2$  biphasic system for porphyrin formation at a high reactant concentration

Entry	Acid/ $\text{mm}^2$ or mM	Solvent	[Reactant]/mM	Time <sup>a</sup> /min	Yield/%	
					TPP	NC-TPP
6 <sup>b</sup>	Interface 200 $\text{mm}^2$ at $[\text{C}_4\text{-SAbim}][\text{CF}_3\text{SO}_3]/\text{CH}_2\text{Cl}_2$	$\text{CH}_2\text{Cl}_2$	145	10	27	4.2
7 <sup>c</sup>	$[\text{C}_4\text{-SAbim}][\text{CF}_3\text{SO}_3]$	$\text{CH}_2\text{Cl}_2$	145	10	7	2
8 <sup>d</sup>	$[\text{C}_4\text{-SAbim}][\text{CF}_3\text{SO}_3]$	$\text{CH}_2\text{Cl}_2$	145	10	11	4
9 <sup>e</sup>	M-SA 50	$\text{CH}_2\text{Cl}_2$	100	8	12	12
10	M-SA 100	$\text{CH}_2\text{Cl}_2$	100	10	2.4	6.8

Reaction condition; 22 °C, [aldehyde] = [pyrrole], [oxidant] = [reactant].

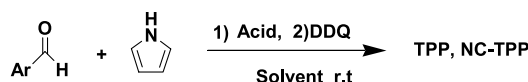
<sup>a</sup> Condensation time.

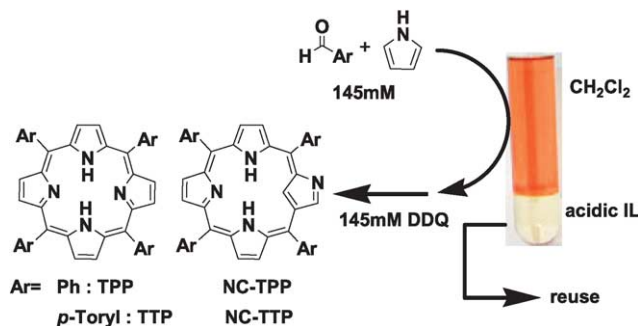
<sup>b</sup> This work; yields were determined after recrystallization.

<sup>c</sup>  $\text{CH}_2\text{Cl}_2$  was placed on the  $[\text{C}_4\text{-SAbim}][\text{CF}_3\text{SO}_3]$  phase for 10 min without shaking. Yields were determined by HPLC analysis.

<sup>d</sup>  $\text{CH}_2\text{Cl}_2$  was pre-equilibrated with the  $[\text{C}_4\text{-SAbim}][\text{CF}_3\text{SO}_3]$  by shaking for 5 min with a vortex mixer. Yields were determined by HPLC analysis.

<sup>e</sup> Lindsey Method; data from Ref. 1, Yields were determined by HPLC analysis.



**Table 5.** Reuse of [C<sub>4</sub>-SAbim][CF<sub>3</sub>SO<sub>3</sub>] at high reactant concentrations

Cycle	1	2	3	4	5	6	7	8	9	10
	Without shaking				With shaking		Without shaking			
TPP (%)	27	24	24	26	1.4	16	7	16	15	16
NC-TTP (%)	4	4	4	4	4.7	2	2	7	3	3
					Without shaking					
TPP (%)	30	31	30	28	27	28	28	29	28	31
NC-TTP (%)	6	4	4	6	7.1	6	6	7	6	5

[Pyrrole]=[aldehyde]=[DDQ]=145 mM, 22 °C, reaction time 10 min, isolated yields were determined after recrystallization.

for the repeated porphyrin preparations. Among the repeated cycles for TPP/NC-TTP formation, only the fifth cycle involved vigorous shaking of the biphasic system, whereas the other cycles, the first to the fourth and the sixth to the tenth, were kept as a silent interface without shaking during the reaction period. For the TTP/NC-TTP reaction, on the other hand, no shaking treatment was applied at all.

From the first cycle through the tenth final cycle, no shaking TPP/NC-TTP preparations, the yields for isolated TPP and NC-TTP ranged from 27 to 31% and from 3.9 to 6.4%, respectively. Despite having used high reactant concentrations, constant yields appeared for all the cycles. On the other hand, the influence of shaking on the isolated yields was studied for the TPP/NC-TTP preparations. Prior to the vigorous shaking, yields of ca. 25 and 4.2% for TPP and NC-TTP, respectively, had been maintained from the first to the fourth cycle, similar to the case of the TPP/NC-TTP preparations. Vigorous shaking of the fifth cycle immediately brought a brown color into the acidic IL phase and dramatically reduced the TPP yield down to 1.4%. Although, the silent interface without shaking was set again for the subsequent condensations from the sixth to the final cycle, the isolated yields of TPP could not reach the values noted prior to the shaking. It was impossible to remove the color from the contaminated, non-volatile IL even by extraction with a halogenated solvent, into which the by-products could readily be dissolved. This fact means that once the acidic IL phase is contaminated with the by-products, the productivity for porphyrins never recovers to the original level.

Based on these results, it can be said that the continually recycled usage of acidic [C<sub>4</sub>-SAbim][CF<sub>3</sub>SO<sub>3</sub>] does not affect the porphyrin yield at all, as long as the contamination arising from the by-products is not transported through the interface by shaking. It is useful to note again that the dichloromethane phase can produce more porphyrins just by being placed on the silent acidic IL, than by being shaken vigorously with the IL.

### 3. Conclusion

These results demonstrate that the formation of tetrapyrrole derivatives in IL is an observable phenomenon. The water content and the viscosity of the used salt affect the reactivity in IL. In the case of the widely used C<sub>n</sub>min ILs, in particular, the trade-off relation between water content and fluidity is relevant to the porphyrin yield. Balancing the two factors as equal priorities is crucial for porphyrin preparation.

Using the acidic IL, [C<sub>4</sub>-SAbim][CF<sub>3</sub>SO<sub>3</sub>] as a reaction medium is unfavourable for porphyrin formation due to its strong acidity and high viscosity of as much as 3185 cP, in addition to the remaining water, which can comprise as much as 1.85 wt%. Despite these demerits, utilizing acidic IL as a biphasic mode with dichloromethane represents superiority both with regard to the reusability of the IL phase and porphyrin productivity in a high reactant concentration. The presence of the interface may act to stop the supply of more acid than is necessary. Further, investigation into the spatial distribution of the TILS around the interface is currently under way in our laboratory.

### 4. Experimental

#### 4.1. Materials

Pyrrole (TCI, 99%), benzaldehyde (Wako, 98%), *p*-tolualdehyde (Wako, 95+) and DDQ (TCI, 97%), CH<sub>2</sub>Cl<sub>2</sub> (Kishida, 98%) were used as received. All other reagents were of a reagent grade and were used as received from Aldrich without further purification. Column chromatography was conducted using Aluminium oxide 90 Active basic (MERCK) and silica gel BW-300SP (FUJI SILYSIA).

#### 4.2. Synthesis of used ILs

[C<sub>4</sub>-SAbim][CF<sub>3</sub>SO<sub>3</sub>], 3-butyl-1-(butyl-4-sulfonyl) imidazolium trifluoromethyl-sulfonate was synthesized according

to the published procedures<sup>15</sup> and the other ILs ranging from [C<sub>4</sub>mim][TFSI] to [C<sub>10</sub>mim][TFSI] were synthesized according to the published general procedures.<sup>11</sup> These ILs included [C<sub>4</sub>mim][TFSI], [C<sub>4</sub>p][TFSI], [C<sub>4</sub>mppr][TFSI], [*n*-(C<sub>6</sub>H<sub>13</sub>)<sub>4</sub>][TFSI], [C<sub>4</sub>mim][PF<sub>6</sub>], [C<sub>4</sub>mim][BF<sub>4</sub>], [C<sub>4</sub>mim][Br], [C<sub>4</sub>mim][CF<sub>3</sub>CO<sub>2</sub>], [C<sub>4</sub>mim][CF<sub>3</sub>SO<sub>3</sub>], [C<sub>2</sub>-mim][TFSI], [C<sub>3</sub>mim][TFSI], [C<sub>5</sub>mim][TFSI], [C<sub>6</sub>mim][TFSI], [C<sub>7</sub>mim][TFSI], [C<sub>8</sub>mim][TFSI], [C<sub>9</sub>mim][TFSI], and [C<sub>10</sub>mim][TFSI]. All the prepared ILs were dried in a vacuum oven (0.08 mmHg, 60 °C, EYELA, VOS-301SD) for at least 24 h and such condition was maintained until the subsequent experiment.

### 4.3. Determination of water content and viscosity

The water content was determined by Karl-Fischer titration using a Karl-Fischer moisture titrator MKC-510N (KEM) at room temperature. The viscosity was measured with a DV-II+Pro Programmable Cone/Plate (CPE-51) Viscometer (BROOKFIELD) at 22 °C via an external temperature controller. Each sample comprised 0.5 mL and measurements were conducted in triplicate. For the experiments of Figures 2 and 3, in particular, after determining the values, the measured samples were immediately mounted into a vessel for porphyrin preparation.

### 4.4. Intended addition of water to [C<sub>4</sub>mim][TFSI]

Shaking the phase-separable [C<sub>4</sub>mim][TFSI] (2 mL) with distilled water (2 mL) by a vortex mixer for 5 min followed by separation with centrifuging (3,000 ppm, 10 min) produced water-saturated [C<sub>4</sub>mim][TFSI]. By mixing the water-saturated [C<sub>4</sub>mim][TFSI] (H<sub>2</sub>O 1.36 wt%) with the freshly vacuumed-dried [C<sub>4</sub>mim][TFSI] (H<sub>2</sub>O 0.12 wt%), three [C<sub>4</sub>mim][TFSI]s containing water to the amount of 0.47, 0.62, 0.96 wt% were prepared.

### 4.5. HPLC analysis of porphyrins

Prior to performing HPLC analysis, the crude reaction mixture containing black tarry by-products was first pre-treated through column chromatography applying basic alumina with chloroform eluent. Then HPLC analysis was performed using a JASCO PU-2089 with a quaternary pump, a thermostatic column compartment to be set at 30 °C, and a diode array UV-vis detector. A silica gel analytical column was selected (nakalai tesque, COSMOSIL, 4.6 mm by 250 mm) with the gradient solvent between hexane and acetone ranging from 95–50/5–50 vol%, respectively. The gradient ratio for the mixing was conditioned to be as follows: 0 min, 5% acetone/95% hexane, 0–30 min, linear increase to 50% acetone/50% hexane. TPP and NC-TPP were eluted at 7 min and 13 min, respectively. The Soret band absorption wavelengths, 417 and 438 nm, were set as the detective monitor for TPP and NC-TPP, respectively.

### 4.6. Protocol for porphyrin preparation using ILs

In the present porphyrin syntheses, the Lindsey method was applied both for the single homogeneous mode and for the biphasic mode, due to its wide generality and excellent productivity. The reaction temperature, concentrations, and

time period are the same as the best conditions for NC-TPP in dichloromethane. The procedure outline is as follows: standing dichloromethane or IL solution of benzaldehyde (10 mM) and pyrrole (10 mM) in the presence of M-SA (7 mM) at 22 °C for 30 min followed by the addition of powdered DDQ (10 mM) provides TPP, NC-TPP, and black tarry by-products. The remaining acid was quenched by the addition of 6 M equiv of triethylamine (TEA) to the used acid. The target porphyrins were isolated by the same procedure as described in the literature.

**4.6.1. A single homogeneous solution mode.** For Tables 1 and 2, Figures 2 and 3. Into 1 mL IL solution of 10 mM benzaldehyde and 10 mM pyrrole at 22 °C, M-SA was added to be 7 mM. After standing at the temperature for 30 min, neat DDQ (10 mM) was added followed by the addition of 6 M equiv of TEA to the acid.

For entries 7 and 8 in Table 4. At first, dichloromethane pre-equilibrated with [C<sub>4</sub>-SABim][CF<sub>3</sub>SO<sub>3</sub>] was prepared in two ways. In the case of entry 8, 10 mL dichloromethane were vigorously shaken with 3 mL [C<sub>4</sub>-SABim][CF<sub>3</sub>SO<sub>3</sub>] for 5 min in a vortex mixer. The mixture was centrifuged (3,000 rpm) for 10 min to separate clearly the two phases. On the other hand, for entry 7, 10 mL dichloromethane were placed on the silent surface of 3 mL [C<sub>4</sub>-SABim][CF<sub>3</sub>SO<sub>3</sub>] without shaking and this was left to standing for 10 min. Into each 1 mL of dichloromethane solution, pyrrole and benzaldehyde were added to be each 145 mM, and this was left to stand for 10 min without the addition of any acid at 22 °C. Into the reaction mixture, DDQ was added to be 145 mM, and then the remaining acid was quenched by the addition of 6 M equiv of TEA to the acid.

**4.6.2. Biphasic (CH<sub>2</sub>Cl<sub>2</sub>/[C<sub>4</sub>-SABim][CF<sub>3</sub>SO<sub>3</sub>]) mode.** Placing 10 mL dichloromethane on the silent surface of 3 mL [C<sub>4</sub>-SABim][CF<sub>3</sub>SO<sub>3</sub>] in a test tube forms the interface of ca. 200 mm<sup>2</sup>. The interface was left to stand for 10 min at 22 °C. Into the upper dichloromethane phase, pyrrole and the corresponding aldehyde were added to be each 145 mM. Although, the dichloromethane phase was immediately coloured, the [C<sub>4</sub>-SABim][CF<sub>3</sub>SO<sub>3</sub>] phase was not coloured at all. The condensation reaction in the upper dichloromethane phase was quenched within 10 min. The dichloromethane phase was taken out from the [C<sub>4</sub>-SABim][CF<sub>3</sub>SO<sub>3</sub>] phase and the oxidation with DDQ was conducted in the separated dichloromethane solution in order to prevent contamination of the acidic IL phase. The separated dichloromethane phase was oxidized by the addition of DDQ (14.5 or 145 mM). The crude reaction mixture containing black tarry by-products was pre-treated with column chromatography on basic alumina with CH<sub>2</sub>Cl<sub>2</sub> eluent followed by a second column chromatography on silica gel with MeOH/CH<sub>2</sub>Cl<sub>2</sub> eluent. The first red fraction and the second brown fraction were collected as TPP and NC-TPP, respectively. Recrystallization with CH<sub>2</sub>Cl<sub>2</sub>/hexane produced TPP and NC-TPP, each as shiny violet crystal.

### Acknowledgements

This work was supported by a Sasakawa Scientific Research

Grant from The Japan Science Society, and by Grants-in-Aid for Scientific Research (B), 16350025, 2004-2006, and for Incentive Research, 16919248, 2004-2005 from the Ministry of Education, Science, Sports and Culture.

### References and notes

- (a) Lindsey, J. S.; Schreiman, I. C.; Hsu, H. C.; Kearney, P. C.; Marguerettaz, A. M. *J. Org. Chem.* **1987**, *52*, 827. (b) Geier, G. R., III; Haynes, D. M.; Lindsey, J. S. *Org. Lett.* **1999**, *9*, 1455. (c) Geier, G. R., III; Lindsey, J. S. *J. Org. Chem.* **1999**, *64*, 1596. (d) Geier, G. R., III; Ciringh, Y.; Li, F.; Haynes, D. M.; Lindsey, J. S. *Org. Lett.* **2000**, *2*, 1745.
- (a) Furuta, H.; Asano, T.; Ogawa, T. *J. Am. Chem. Soc.* **1994**, *116*, 767. (b) Chmielewski, P. J.; Latos-Grazynski, L.; Rachlewicz, K.; Glowiak, T. *Angew. Chem., Int. Ed. Engl.* **1994**, *33*, 779. (c) For recent review: Furuta, H.; Maeda, H.; Osuka, A. *Chem. Commun.* **2002**, 1795.
- (a) Seddon, K. R. *J. Chem. Tech. Biotechnol.* **1997**, *68*, 351. (b) Welton, T. *Chem. Rev.* **1999**, *99*, 2071. (c) Wasserscheid, P.; Keim, W. *Angew. Chem., Int. Ed.* **2000**, *39*, 3772. (d) Sheldon, R. *Chem. Commun.* **2001**, 2399. (e) Dupont, J.; Souza, R. F. de; Suqrez, P. A. Z. *Chem. Rev.* **2002**, *102*, 3667. (f) Rogers, R. D.; Seddon, K. R. *Science* **2003**, *302*, 792.
- Wasserscheid, P.; Gordon, C. M.; Hilgers, C.; Muldoon, M. J.; Dunkin, I. R. *Chem. Commun.* **2001**, 1186.
- Carmichael, A. J.; Earle, M. J.; Holbery, J. D.; McCormac, P. B.; Seddon, K. R. *Org. Lett.* **1999**, *1*, 997.
- Chauvin, Y.; Mussman, L.; Oliver, H. *Angew. Chem., Int. Ed. Engl.* **1995**, *34*, 2698.
- Adams, C. J.; Earle, M. J.; Roberts, G.; Seddon, K. R. *Chem. Commun.* **1998**, 2097.
- (a) Earle, M. J.; McCormac, P. B.; Seddon, K. R. *Green Chem.* **1999**, *1*, 23. (b) Aggarwal, A.; Lancaster, N. L.; Sethi, A. L.; Welton, T. *Green Chem.* **2002**, *4*, 517.
- (a) Khan, F. A.; Dash, J.; Satapathy, R.; Upadhyay, S. K. *Tetrahedron Lett.* **2004**, *45*, 3055. (b) Wang, B.; Gu, Y.; Luo, C.; Yang, T.; Yang, L.; Suo, J. *Tetrahedron Lett.* **2004**, *45*, 3417.
- Kitaoka, S.; Nobuoka, K.; Ishikawa, Y. *Chem. Commun.* **2004**, 1902.
- (a) Bonhôte, P.; Dias, A.-P.; Papageorgiou, N.; Kalyanasundaram, K.; Grätzel, M. *Inorg. Chem.* **1996**, *35*, 1168. (b) Huddleston, J. G.; Visser, A. E.; Reichert, W. M.; Willauer, H. D.; Broker, G. A.; Rogers, R. D. *Green Chem.* **2001**, *3*, 156.
- Investigation into the trade-off relation<sup>4</sup> between the yields of NC-TPP and those of TPP is currently in progress.
- Dsyuba, S. V.; Bartsch, R. A. *ChemPhysChem* **2002**, *3*, 161.
- Due to the poor yields of NC-TPP, we avoid this discussion from the same standpoint as that for TPP formation.
- Cole, A. C.; Jensen, J. L.; Ntai, I.; Tran, K. L.; Weaver, K. J.; Forbes, D. C.; Davis, J. H., Jr. *J. Am. Chem. Soc.* **2002**, *124*, 5962.
- Qiao, K.; Yokoyama, C. *Chem. Lett.* **2004**, *33*, 472.

# Acremines A–F, novel secondary metabolites produced by a strain of an endophytic *Acremonium*, isolated from sporangiophores of *Plasmopara viticola* in grapevine leaves<sup>☆</sup>

Gemma Assante,<sup>a</sup> Sabrina Dallavalle,<sup>b,\*</sup> Luciana Malpezzi,<sup>c</sup> Gianluca Nasini,<sup>c,\*</sup> Santella Burruano<sup>d</sup> and Livio Torta<sup>d</sup>

<sup>a</sup>Istituto di Patologia Vegetale, Università degli Studi, via Celoria 2, 20133 Milano, Italy

<sup>b</sup>Dipartimento di Scienze Molecolari Agroalimentari, Università degli Studi, via Celoria 2, 20133 Milano, Italy

<sup>c</sup>Dipartimento di Chimica, Materiali ed Ingegneria Chimica 'Giulio Natta' del Politecnico, CNR-Istituto di Chimica del Riconoscimento Molecolare, Sezione 'Adolfo Quilico'; via Mancinelli 7, 20131 Milano, Italy

<sup>d</sup>Dipartimento S.EN.FI.MI.O, Università degli Studi, Viale delle Scienze 13, 20128 Palermo, Italy

Received 30 March 2005; revised 27 May 2005; accepted 30 May 2005

Available online 17 June 2005

**Abstract**—Six novel metabolites, acremines A–F have been isolated from agar cultures of a strain of *Acremonium* sp. Their structures and stereochemistry were elucidated using a combination of <sup>13</sup>C and <sup>1</sup>H homo and heteronuclear 2D NMR experiments and X-ray analysis. Acremines A–D inhibited the germination of sporangia of *Plasmopara viticola*.

© 2005 Elsevier Ltd. All rights reserved.

## 1. Introduction

A strain of *Acremonium* named A20, isolated from sporangiophores of *Plasmopara viticola*, showed antagonistic properties against this oomycetous phytopathogen.<sup>2</sup> The fungus was particularly effective in causing early degeneration of sporangiophore branches, by showing to be intimately connected to the plant pathogen, growing and rapidly bridling the sporangia until their collapse on the underlying plant tissues. The A20 cultural filtrates decreased the germinability of *P. viticola* sporangia and the growth of others phytopathogens, when added at different concentrations to the cultural medium.<sup>2</sup>

In the anamorphic polyphyletic taxon *Acremonium* a 100 species have been described, many of them responsible for production of biologically active metabolites, including the  $\beta$ -lactam antibiotics cephalosporins,<sup>3</sup> the immunosuppressants cyclosporins,<sup>4</sup> the tremorgenic indole-diterpenoids lolitrems<sup>5</sup> and prenylated phenols inhibitors of *N*-

SMase.<sup>6</sup> Endophytic fungi are a good source of novel secondary metabolites<sup>7</sup> and the endophyte behaviour of many *Acremonium* spp. in *Gramineae* has been positively related to resistance of the host grass against aphids and other important insect pasture pests, but it is also at the basis of very potent toxicoses in human and animals.<sup>8</sup>

As part of a program carried out to understand the nature of the interaction between *Acremonium* sp. strain A20 and the oomycetous plant pathogen *P. viticola*, we describe here the isolation of the novel acremines A–F, produced by A20 grown on a sugar-rich cultural medium. We also assessed the activity of these metabolites on germinability of *P. viticola* sporangia.

## 2. Results and discussion

*Acremonium* sp. A20, isolated from grapevine leaves infected by *P. viticola*, was cultured on corn step sugar agar for 2 weeks and the metabolites were extracted with EtOAc. The crude extracts, which showed a significant activity towards *P. viticola* sporangia, were submitted to successive chromatographic fractionation and purification, yielding a family of six novel compounds, named acremine A (**1a**), B (**2**), C (**3a**), D (**4a**), E (**4b**) and F (**5a**).

<sup>☆</sup> See Ref. 1.

**Keywords:** *Acremonium*; *Plasmopara viticola*; Acremine; Isolation; Natural product; NMR; X-ray analysis.

\* Corresponding authors. Tel.: +39 250316816; fax: +39 250316801 (S.D.); e-mail addresses: sabrina.dallavalle@unimi.it; gianluca.nasini@polimi.it

Structure assignments of the isolated compounds were based on spectroscopic data, especially those from NMR and MS analysis.

Compound **1a** was isolated as colourless needles, mp 123–125 °C;  $[\alpha]_D +22.3$  ( $c$  0.04; MeOH); the CIMS showed a  $[\text{MH}]^+$  at  $m/z$  227 corresponding to a molecular formula  $\text{C}_{12}\text{H}_{18}\text{O}_4$ ; the HREIMS measure indicated a  $[\text{M}^+ - \text{H}_2\text{O}]$  at  $m/z$  208 ( $\text{C}_{12}\text{H}_{16}\text{O}_3$ ).

The  $^1\text{H}$  NMR spectrum revealed two signals at 6.70 ppm (d) and 6.46 ppm (d) with a coupling constant of 16.48 Hz, providing evidence of a *trans* double bond. The presence of a further olefinic hydrogen was inferred from a signal (d) at 5.90 ppm. From the magnitude of the coupling constant ( $J=1.86$  Hz, allylic) it was apparent that this second double bond was trisubstituted.

In the  $^{13}\text{C}$  NMR spectrum a signal at 199.8 ppm indicated the presence of a conjugated CO group, which was supported by the IR spectrum ( $\nu_{\text{max}}(\text{KBr})$  1682  $\text{cm}^{-1}$ ).

Considering the molecular formula, three of the implied degrees of unsaturation were explained by the double bonds and the carbonyl group. This led to hypothesize the presence of a cyclic structure.

Information from  $^{13}\text{C}$  spectrum in conjunction with DEPT showed only one methylene group at 44.5 ppm. The hydrogens of this group appeared as two double doublets in the  $^1\text{H}$  spectrum (2.12 and 2.32 ppm,  $J=7.02$ , 13.50 and 4.56, 13.50 Hz, respectively) coupled with a CH at 4.65 ppm in the  $^1\text{H}$  NMR and 65.1 ppm in the  $^{13}\text{C}$  NMR. The shift of this methine suggested that it was oxygenated. In addition, the allylic coupling constant with the olefinic proton at 5.90 ppm allowed us to connect this moiety to the trisubstituted double bond.

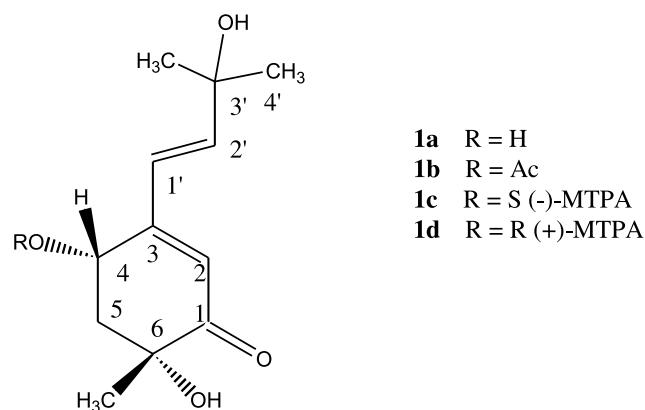
The most upfield signals in the  $^1\text{H}$  spectrum were two singlets at 1.32 and 1.20 ppm, corresponding to three methyl groups, two of them geminal; their multiplicity indicated that they were on quaternary carbons. Examination of HMBC spectra showed that these carbons resonated at 69.8 and 72.4 ppm, thus confirming that they were oxygenated as well as the carbon previously described. Three broad signals in the  $^1\text{H}$  NMR spectrum (4.63, 4.56, 3.87 ppm) that exchanged with  $\text{D}_2\text{O}$  corroborated the presence of three hydroxyl groups.

The above information along with closer examination of NOESY and HMBC experiments allowed unambiguous structure assignment and the trivial name acremine A is proposed for **1a**.

The relative position of the substituents was further confirmed by reduction of **1a** with  $\text{NaBH}_4$  to obtain the corresponding alcohol **5a** in, which the new hydrogen atom at C-1 ( $^1\text{H}$  NMR:  $\delta$  3.95 ppm) showed a coupling constant with the olefinic proton at C-2 ( $J=2.57$  Hz).

Treatment of compound **1a** with  $\text{Ac}_2\text{O}/\text{Py}$  afforded the monoacetyl derivative **1b**, which showed in  $^1\text{H}$  NMR spectrum a significant downfield shift of the methine proton

on C-4 (5.9 ppm) with respect to the corresponding proton in the parent compound **1a** (4.65 ppm).



Acremine A and derivatives

Single crystal X-ray analysis of compound **1a** was undertaken in order to determine the relative configuration of the two chiral centres of the molecule. The molecular structure of acremine A, reported in Figure 1, shows opposite chirality of the two asymmetric centres at C4 and C6. The configuration around the C1'–C2' double bond is *trans*, as confirmed by the torsion angle C3–C1'–C2'–C3' of 176.9(2)°. The bond length C1'–C2' [1.311(3) Å] is typical for a localized, non-conjugated, double bond.<sup>9</sup> The geometry around the C3–C1' bond, connecting the two double bonds gives a *cis* configuration, with a torsion angle C2–C3–C1'–C2' of 14.9(4)°. The six-membered cyclohexene ring adopts the half-chair conformation [ring puckering parameters:  $Q_T=0.458(2)$  Å,  $\theta_2=50.2(3)^\circ$  and  $\phi_2=-92.9(4)^\circ$ ],<sup>10</sup> with atoms C5 and C6 deviating from the C1/C2/C3/C4 plane by  $-0.38$  and  $+0.32$  Å, respectively.

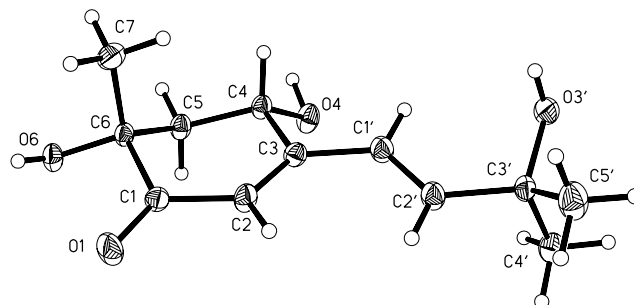
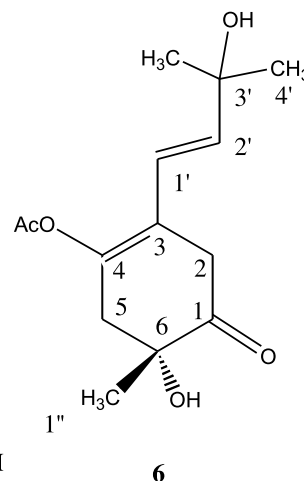
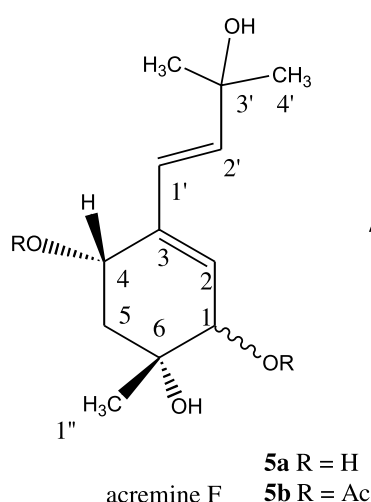
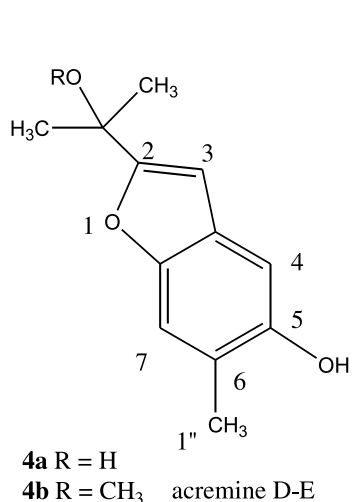
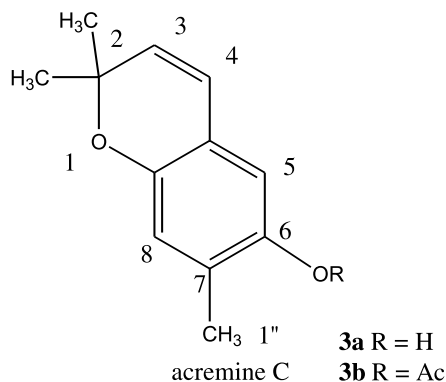
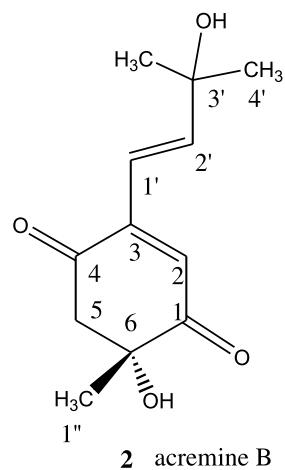


Figure 1. A view of the molecule **1a**, as obtained by X-ray diffraction, with atom labeling. Displacement ellipsoids are drawn at 30% probability level.

In the crystal packing the molecules are linked via strong O–H $\cdots$ O and weak C–H $\cdots$ O hydrogen bonds to form thick sheets parallel to the (100) plane, (see Fig. 2).

The absolute configuration at C-4 of **1a** was elucidated by applying the modified Mosher's method<sup>11</sup> to the (*S*) and (*R*)-MTPA ( $\alpha$ -methoxy- $\alpha$ -trifluoromethyl phenylacetic acid) esters **1c** and **1d** obtained by reacting **1a** with the corresponding MTPAs. The *S* configuration at C-4 was easily deduced from the  $\Delta\delta$  values ( $\Delta\delta=\delta S-\delta R$ ) obtained by subtracting the chemical shift ( $\delta R$ ) of each proton of the (*R*)-MTPA ester from that ( $\delta S$ ) of the (*S*)-MTPA ester. In

fact, all the protons lying in the left hand side of the plane containing the ester group of MTPA had negative  $\Delta\delta$  values as a consequence of the shielding effect exerted by the phenyl ring of the Mosher's acid (Figs. 3 and 4).



Compound **2** was obtained as a yellow powder, mp 95–97 °C;  $[\alpha]_D -79.4$  (*c* 0.06; CHCl<sub>3</sub>) and analysed as C<sub>12</sub>H<sub>16</sub>O<sub>4</sub>; the IR spectrum (KBr) exhibited a strong absorption band (conj. CO group) at 1683 cm<sup>-1</sup> like acremine A; furthermore **2** could not be acetylated and a yellow EtOAc solution was discoloured by treatment with sodium dithionite.

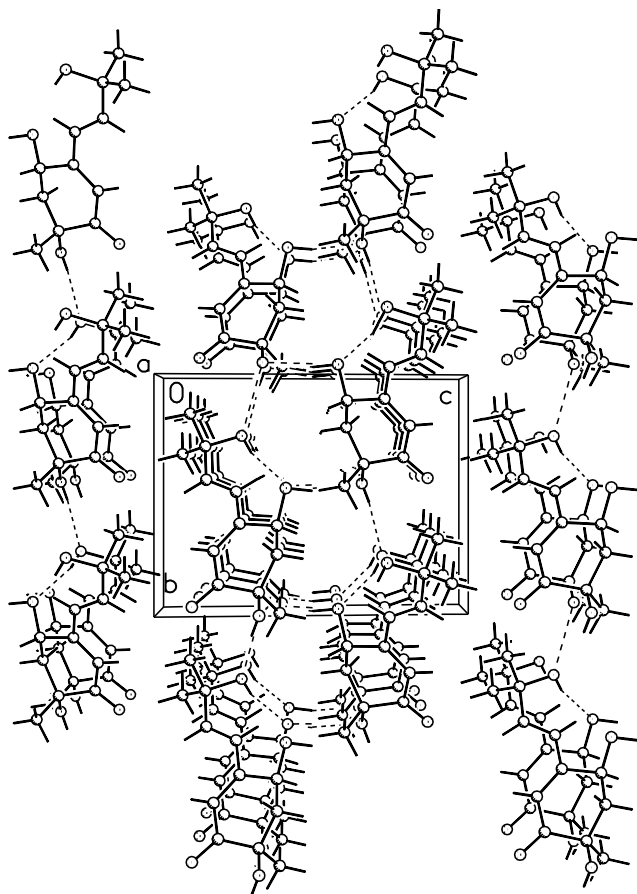
Based on <sup>13</sup>C and <sup>1</sup>H NMR spectral analysis, the structural features of **2** were very close to those of **1a**. The spectra accounted for 12C and 16H atoms. In the <sup>1</sup>H NMR spectrum, the presence of a *trans* double bond was clearly indicated by two signals at 6.50 and 6.80 ppm (*J* = 15.96 Hz). The third olefinic proton, at 6.74 ppm, was shifted downfield in comparison with the corresponding H of compound **1a**. Three methyl groups resonated as singlets at 1.37 and 1.38 ppm.

The greatest difference from the spectrum of compound **1a** was the absence of the methine signal at 4.65 ppm. This information, along with the presence in the <sup>13</sup>C spectrum of two carbonyl groups at 195.4 and 202.0 ppm, suggested that

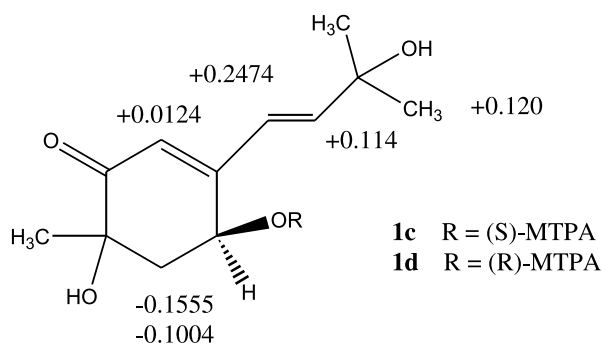
in **2** the –CHOH moiety at C-4 was replaced by a CO group. A further confirmation of this assumption was obtained from the observation that the hydrogens of the methylene group appears as an AB system with a geminal coupling

constant (*J* = 15.16 Hz) without any further coupling. When treated with Zn/Ac<sub>2</sub>O (Thiele reduction) at rt, compound **2** formed compound **6**, whose structure was determined as follows: the <sup>1</sup>H spectrum revealed the disappearance of the olefinic proton at 6.80 ppm and showed a new AB system at 2.7 ppm with a geminal coupling constant of 17.35 Hz, providing evidence of the presence of a further methylene group in the ring. This is in agreement with the proposed conjugate mechanism of the reduction of unsaturated 1,4-diketones,<sup>12</sup> expected to proceed with primary formation of the dienediol followed by ketonization to obtain the saturated 1,4-diketone. In our case, the enol of ketone in position 4 is trapped by acetic anhydride to give compound **6**. Indeed, the absence of further coupling constant of the new AB system and the presence of a singlet integrating for three protons at 2.1 ppm confirmed that C-4 is in the acetylated enolic form. Consistently, the <sup>13</sup>C NMR spectrum showed the disappearance of one of the two carbonyl moieties and the presence of two methylene groups resonating at 42.7 and 35.7 ppm.

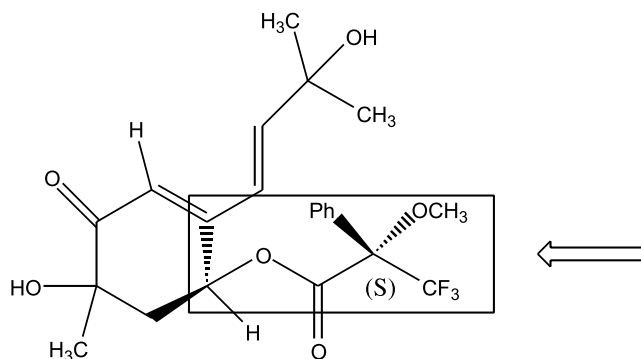
Acremine C (**3a**) is an oil with an analysis consistent with



**Figure 2.** A packing diagram, viewed along the *a* axis, showing the hydrogen bonding interactions (dashed lines).



**Figure 3.** Differences of the proton chemical shifts ( $\Delta\delta = \delta_S - \delta_R$ ) of MTPA Mosher's esters of compound **1a**.



**Figure 4.** MTPA plane for the (S) MTPA ester used to assign the absolute configuration at  $C_4$  for **1a**.

the formula  $C_{12}H_{14}O_2$ . It was optically inactive and its IR spectrum did not show carbonyl bands.

The structure was determined as follows:  $^1H$  and  $^{13}C$  spectra disclosed signals and correlations for 12C and 14H atoms. The double bond was still present, as confirmed by two signals at 5.55 and 6.19 ppm in the  $^1H$  NMR spectrum but, unlike for compounds **1a** and **2**, the magnitude of the coupling constant (9.57 Hz) suggested a *cis* orientation.  $^{13}C$  and HMQC NMR analysis revealed the presence of six carbons, four of them quaternary, in the aromatic region between 112 and 147 ppm, in addition to the signals of the carbons of the double bond (121.9 and 130.7 ppm). The downfield signals at 147.58 and 146.31 ppm indicated that two of these aromatic quaternary carbon atoms were oxygenated (in fact, one exchangeable hydrogen was present at 4.7 ppm). The presence of an aromatic ring conjugated with the double bond was supported by the analysis of the UV spectrum which showed maxima at 230, 267 and 331 nm ( $\epsilon$  18,390, 2900 and 3650). In the  $^1H$  NMR the two aromatic hydrogens resonated as singlets at 6.41 and 6.56 ppm. The shielded nature of their resonances suggested that both these hydrogens were *ortho* to the oxygenated carbon atoms, while their multiplicities confirmed a relative *para* orientation. As in compounds **1a** and **2**, the two geminal methyl groups were still present at 1.39 ppm, but in **3a** the third methyl group appeared as a singlet downfield (2.16 ppm) to the corresponding methyl in compounds **1a** and **2**. This is consistent with the chemical shift of a methyl group on an aromatic ring. The above observations and the fact that only a monoacetate was obtained after treatment with  $Ac_2O/Py$  (**3b**) suggested a chromene ring.

Acremine D (**4a**) was obtained as a white powder, mp 142–145 °C; the EIMS showed a molecular ion peak  $[M]^+$  at  $m/z$  206 consistent with the formula  $C_{12}H_{14}O_3$ .  $^1H$  and  $^{13}C$  spectra accounted for 12C and 14H atoms, therefore the compound should contain three oxygen atoms. The presence of an aromatic ring, inferred from a set of six carbons in the region between 108 and 152 ppm, suggested a correlation with the structure of **3a**. As in acremine C, two of the aromatic carbons were oxygenated. The  $^1H$  NMR spectrum displayed a tetrasubstituted phenyl group showing two singlets at 7.15 and 6.91 ppm assigned to protons in *para* position. A methyl group linked to the aromatic ring resonated at 2.26 ppm, while the signal at 1.54 ppm, integrating for six protons, was due to the geminal methyl groups on the chain. The most remarkable difference with the spectrum of **3a** was the disappearance of one of the olefinic protons, leading as a consequence to the second olefinic proton resonating as a singlet at 6.44 ppm. These facts suggested that also this compound had a bicyclic structure but, in this case, the cyclization had taken place between one of the carbons on the double bond and a phenolic oxygen on the ring, thus leading to a benzofuran ring. In the literature, there are some examples of this kind of biosynthetic cyclization.<sup>13</sup> Upon rationalizing the above data the structure of this compound was established as depicted in formula **4a**.

The  $^1H$  NMR spectrum of compound **4b** revealed a set of signals very similar to those of **4a**, except for the presence of a singlet integrating for three protons at 3.15 ppm (see



Section 3). This fact suggested the presence of a methoxy group instead of a hydroxy group on the chain in position 2; the EIMS showing a molecular ion peak  $[M]^+$  at  $m/z$  220, consistent with the formula  $C_{13}H_{16}O_3$ , and two fragments at  $m/z$  205 and  $m/z$  189, confirmed this hypothesis.

Acremine F (**5a**) was isolated in poor yield as an oil;  $[\alpha]_D^{25} +56$  ( $c$  0.2;  $CHCl_3$ ), from the more polar chromatographic fractions and had an analysis consistent with the formula  $C_{12}H_{20}O_4$ , two hydrogens more as in acremine A (**1a**). This suggested the reduction of the carbonyl group confirmed by comparison with the product **5a** obtained by chemical reduction of **1a**, both products showing identical NMR data. Acetylation of **5a** led to the diacetyl derivative **5b**; due to the instability of acremine E, we discontinued further study on its stereochemistry.

Biosynthetically, all acremines are probably related: these compounds possess a cyclohexene or aromatic part, possibly of poliketide origin, substituted with a prenyl unit. From Acremine A or F, different cyclization reactions would then yield the chromene or furan ring.

Acremines A–D were tested for their capability to inhibit germination of *P. viticola* sporangia and results are presented in Table 2. Germinability of sporangia was susceptible to acremines A–D at all concentrations. However, assuming a break-point of 60% inhibition, only acremine C exceeded this value at concentrations  $>0.5$  mM.

### 3. Experimental

#### 3.1. General

Flash column chromatography was performed with Merck silica gel (0.040–0.63 mm); thin and preparative layer chromatography (TLC and PLC) were performed on precoated Merck silica gel 60 F254 plates. The IR spectra were measured on a Perkin–Elmer 177 spectrophotometer. MS spectra were recorded with a Finnigan–Mat TSQ70 and Bruker Esquire 3000 Plus instruments; HRMS with a Bruker APEX-QZT ICR. The NMR spectra were recorded with a Bruker AMX-600 spectrometer, at 600.13 MHz for  $^1H$  and 150.92 MHz for  $^{13}C$ .

Table 1. NMR spectroscopic data of compound **1a**<sup>a</sup>

Position	Number of protons	$\delta_H$ (ppm), ( $J$ )	$^{13}C$ $\delta$ (ppm)	$^1H$ – $^{13}C$ HMBC correlations	NOESY correlations
1	/	/	199.8		
2	1	5.90d ( $J=1.86$ Hz)	121.8	2, 4, 7	7, 8
3	—	—	158.7		
4	1	4.65ddd ( $J=1.86, 4.56, 7.02$ Hz)	65.1		12, 3, 8
5	2	2.32dd ( $J=13.50, 4.56$ Hz) 2.12dd ( $J=13.50, 7.02$ Hz)	44.5	4, 2, 5, 1	12, 4
6	—	—	72.4		
1'	1	6.46d ( $J=15.96$ Hz)	123.5	4, 9, 8, 6	8, 4, 6, 10, 11
2'	1	6.70d ( $J=15.96$ Hz)	147.1	10, 11, 9, 7, 5	7, 10, 11, 6, 4
3'	—	—	69.8		
4'	3	1.32s	28.4	8, 9	7, 8
5'	3	1.32s	28.4	8, 9	7, 8
1''	3	1.26s	23.8	1, 2	

<sup>a</sup> Recorded at 300 MHz in  $[^2H_6]$ acetone.

#### 3.2. Culture of *Acremonium* sp., strain A20, extraction and isolation of acremines A–F

The fungal strain A20 was isolated from grapevine leaves cv. Regina bianca infected with *P. viticola* in 1996 at Mazara del Vallo (Trapani, Sicily). It was identified as an *Acremonium* sp., by conventional taxonomy. Batch cultures were grown in 40 Roux flasks containing 100 mL CSA (corn steep liquor  $10$  g  $L^{-1}$ , glucose  $90$  g  $L^{-1}$ , sucrose  $100$  g  $L^{-1}$ , yeast extract  $5$  g  $L^{-1}$ ,  $K_2HPO_4$   $2$  g  $L^{-1}$ , and agar  $15$  g  $L^{-1}$ ). Extraction of flasks was made twice with EtOAc/MeOH (100:1). The extracts (2.5 g) were chromatographed on a silica gel flash column eluted with hexane/EtOAc at increasing polarity. Further purification by PLC in  $CH_2Cl_2/MeOH$  15:1 gave the metabolites in order of elution: acremine C, 230 mg,  $R_f$  0.7 (hexane/EtOAc 1:1); acremine D, 15 mg, 0.5; acremine E, 2 mg, 0.45; acremine B, 247 mg, 0.4; acremine A, 620 mg, 0.2; acremine F, 10 mg, 0.1.

**3.2.1. Acremine A (1a).** 4*S*,6*R*-Dihydroxy-3-[*E*-3'-hydroxy-3'-methyl-but-1-enyl]-6-methyl-cyclohex-2-en-1-one. UV:  $\lambda_{max}$  201 and 279 nm ( $\epsilon$  8700 and 20,000). (Found: C, 63.2; H, 8.2  $C_{12}H_{18}O_4$  requires C, 63.70; H, 8.0%); FABMS,  $m/z$  265 ( $M+K$ )<sup>+</sup> (10%), 249 ( $M+Na$ )<sup>+</sup> (20), 209 (100), 101 (65), 163 (50) and 121 (90); HREIMS,  $m/z$  208.1095 (calcd for  $C_{12}H_{16}O_3$  208.1099). The  $^1H$  and  $^{13}C$  NMR data are listed in Table 1.

**3.2.2. Acetylation of acremine A.** Compound **1a** (30 mg) was dissolved in dry pyridine (0.2 mL) and treated with  $Ac_2O$  (0.5 mL) overnight at 0 °C. Standard work-up followed by PLC in silica-gel in hexane/EtOAc (2:1) gave the acetate **1b** as an oil, EIMS,  $m/z$  269 ( $MH$ )<sup>+</sup> and 251.  $^1H$  NMR [ $^2H_6$ ]acetone  $\delta$ : 1.30 (3H, s, H-1''), 1.31 (3H, s, H-4'), 1.32 (3H, s, H-5'), 2.08 (3H, s, Ac), 2.00–2.13 (1H, m, H-5), 2.45 (1H, dd,  $J=5.52, 12.87$  Hz, H-5), 3.93 (1H, br s, OH), 4.25 (1H, br s, OH), 5.87 (1H, ddd,  $J=1.84, 5.52, 6.99$  Hz, H-4), 6.11 (1H, d,  $J=1.84$  Hz, H-2), 6.34 (2H, m, H-1', H-2').

**3.2.3. Compounds 1c and 1d (Mosher's esters of acremine A).** To two solutions of compound **1a** (10 mg) in  $CH_2Cl_2$  (2 mL), each containing DMAP (few crystals) and DCC (30 mg), 20 mg of (*S*)-(–)MPTA and (*R*)-(+)-MPTA were added, respectively. Each mixture was stirred

at rt for 6 h, and the products **1c** and **1d** were purified by PLC using hexane/EtOAc (2:1) as eluent. **1c,1d**: ESI-MS  $m/z$  465 (M+Na)<sup>+</sup>, 225.

**Compound 1c.** <sup>1</sup>H NMR (CDCl<sub>3</sub>) δ: 1.31 (6H, s, H-4', H-5'), 1.38 (3H, s, H-1''), 2.07 (1H, dd,  $J=9.68, 12.65$  Hz, H-5), 2.64 (1H, dd,  $J=5.58, 12.65$  Hz, H-5), 3.49 (3H, s, -OCH<sub>3</sub>), 6.03 (1H, ddd,  $J=1.86, 5.58, 9.68$  Hz, H-4), 6.20 (1H, d,  $J=1.86$  Hz, H-2), 6.25 (1H, d,  $J=16$  Hz, H-1'), 6.34 (1H, d,  $J=16$  Hz, H-2'), 7.42–7.51 (5H, m, 5Ar).

**Compound 1d.** <sup>1</sup>H NMR (CDCl<sub>3</sub>) δ: 1.19 (6H, s, H-4', H-5'), 1.39 (3H, s, H-1''), 2.17 (1H, dd,  $J=9.68, 12.65$  Hz, H-5), 2.72 (1H, dd,  $J=5.58, 12.65$  Hz, H-5), 3.54 (3H, s, -OCH<sub>3</sub>), 5.98 (1H, ddd,  $J=1.86, 5.58, 9.68$  Hz, H-4), 6.00 (1H, d,  $J=15.63$  Hz, H-1'), 6.19 (1H, d,  $J=1.86$  Hz, H-2), 6.23 (1H, d,  $J=15.63$  Hz, H-2'), 7.42–7.51 (5H, m, 5Ar).

**3.2.4. Acremine B (2).** 6*R*-Hydroxy-3-[*E*-3'-hydroxy-3'-methyl-but-1-enyl]-6-methylcyclohex-2-ene-1,4-dione. UV: λ<sub>max</sub> 212 and 301 nm (ε 10,500 and 11,000). (Found C, 63.9; H, 7.0 C<sub>12</sub>H<sub>16</sub>O<sub>4</sub> requires C, 64.27; H, 7.19%). EIMS  $m/z$  207 (MH-18)<sup>+</sup>. <sup>1</sup>H NMR (CDCl<sub>3</sub>) δ: 1.30 (3H, s, H-1''), 1.37 (6H, s, H-4', H-5'), 1.38 (3H, s, H-1''), 3.03 (1H, d,  $J=15.16$  Hz, H-5), 3.11 (1H, d,  $J=15.16$  Hz, H-5), 6.50 (1H, d,  $J=15.96$  Hz, H-1'), 6.74 (1H, s, H-2), 6.80 (1H, d,  $J=15.96$  Hz, H-2'); <sup>13</sup>C NMR (CDCl<sub>3</sub>) δ: 27.6 (C-1''), 29.5 (C-4', C-5'), 53.1 (C-5), 71.42 (C-3'), 75.1 (C-6), 118.31 (C-1'), 129.8 (C-2), 148 (C-3), 149.36 (C-2'), 195.4 (C-4), 202 (C-1).

**3.2.5. Acremine C (3a).** 2,2,7-Trimethyl-2*H*-chromen-6-ol. (Found C, 76.0; H, 7.3 C<sub>12</sub>H<sub>14</sub>O<sub>2</sub> requires C, 75.76; H, 7.42%). EIMS  $m/z$  190 (M)<sup>+</sup> (85), 175 (100), 145 (24) and 131 (15). <sup>1</sup>H NMR (CDCl<sub>3</sub>) δ: 1.39 (6H, s, H-1', H-2'), 2.16 (3H, s, 1''), 5.55 (1H, d,  $J=9.57$  Hz, H-3), 6.19 (1H, d,  $J=9.57$  Hz, H-4), 6.41 (1H, s, H-5), 6.56 (1H, s, H-8); <sup>13</sup>C NMR (CDCl<sub>3</sub>) δ: 15.9 (C-1''), 27.5 (C-1', C-2'), 75.7 (C-2), 112.4 (C-5), 117.6 (C-8), 119.7 (C-4a), 122 (C-4), 124.7 (C-7), 130.7 (C-3), 146.3 (C-8a), 147.6 (C-6).

**3.2.6. Acetylation of compound 3a.** Compound **3a** (10 mg) was acetylated as above with pyridine/Ac<sub>2</sub>O. PLC of the residue with hexane/EtOAc (4:1) gave the monoacetate **3b**; CIMS  $m/z$  233 (MH)<sup>+</sup> and 175. <sup>1</sup>H NMR [<sup>2</sup>H<sub>6</sub>]acetone δ: 1.40 (6H, s, H-1', H-2'), 2.08 (3H, s, Ac), 2.28 (3H, s, H-1''), 5.56 (1H, d,  $J=9.68$  Hz, H-3), 6.22 (1H, m,  $J=9.68$  Hz, H-4), 6.61 (2H, s, H-5, H-8); <sup>13</sup>C NMR (CDCl<sub>3</sub>) δ: 16.2 (C-1''), 20.8 (Ac), 27.9 (C-1', C-2'), 76.3 (C-2), 118.2 (C-8), 119 (C-4a), 119.2 (C-5), 119.6 (C-7), 121.6 (C-4), 130.5 (C-3), 142.7 (C-6), 150.4 (C-8a), 169.6 (Ac).

**3.2.7. Acremine D (4a).** 2-(1'-Hydroxy-1'-methylethyl)-6-methylbenzofuran-5-ol. White solid, mp 142–145 °C. (Found C, 69.7; H, 6.5 C<sub>12</sub>H<sub>14</sub>O<sub>3</sub> requires C, 69.88; H, 6.84%). UV: λ<sub>max</sub> 209, 250 and 296 nm (ε 25,250, 12,280 and 5560); EIMS  $m/z$  206 (M)<sup>+</sup> and 18. <sup>1</sup>H NMR [<sup>2</sup>H<sub>6</sub>]acetone δ: 1.54 (6H, s, H-2', H-3'), 2.26 (3H, s, H-1''), 6.44 (1H, s, H-3), 6.91 (1H, s, H-4), 7.15 (1H, s, H-7); <sup>13</sup>C NMR [<sup>2</sup>H<sub>6</sub>]acetone δ: 16.0 (C-1''), 27.3 (C-2', C-3'), 77.8 (C-1'), 99.6 (C-3), 104.7 (C-4), 111.8 (C-7), 122.3 (C-6), 135.1 (C-3a), 144.3 (C-7a), 150.0 (C-5), 165.3 (C-2).

**3.2.8. Acremine E (4b).** 2-(1'-Methoxy-1'-methylethyl)-6-methylbenzofuran-5-ol. White solid, EIMS  $m/z$  220 (M)<sup>+</sup> (50%), 205 (90) and 189 (100); HREIMS,  $m/z$  220.1093 (calcd for C<sub>13</sub>H<sub>16</sub>O<sub>3</sub> 220.1099). <sup>1</sup>H NMR (CDCl<sub>3</sub>) δ: 1.62 (6H, s, H-2', H-3'), 2.35 (3H, s, H-1''), 3.15 (3H, s, -OCH<sub>3</sub>), 6.50 (1H, s, H-3), 6.90 (1H, s, H-4), 7.24 (1H, s, H-7).

**3.2.9. Acremine F (5a).** 3-(*E*-3'-Hydroxy-3'-methyl-but-1-enyl)-6-methylcyclohex-2-ene-1,4,6-triol. Oil. (Found C, 62.9; H, 8.7 C<sub>12</sub>H<sub>20</sub>O<sub>4</sub> requires C, 63.13; H, 8.83%). ESIMS  $m/z$  251 (M+Na)<sup>+</sup> 211, 193 and 175; CIMS  $m/z$  210 (M-18)<sup>+</sup>. <sup>1</sup>H NMR [<sup>2</sup>H<sub>6</sub>]acetone δ: 1.24 (3H, s, H-1''), 1.28 (6H, s, H-4', H-5'), 1.81 (1H, dd,  $J=14.34, 4.41$  Hz, H-5), 2.02–2.08 (1H, m, H-5), 3.95 (1H, d,  $J=2.57$  Hz, H-1), 4.24–4.31 (1H, m, H-4), 5.52 (1H, d,  $J=2.57$  Hz, H-2), 6.09 (1H, d,  $J=16.18$  Hz, H-1'), 6.17 (1H, d,  $J=16.18$  Hz, H-2').

**3.2.10. Acetylation of compound 5a (5b).** Compound **5a** (10 mg) was acetylated as usual. PLC of the residue with hexane/EtOAc (4:1) gave the diacetate **5b**. <sup>1</sup>H NMR (CDCl<sub>3</sub>) 1.25 (3H, s, H-1''), 1.30 (6H, s, H-4', H-5'), 1.98–2.3 (2H, m, H-5), 2.09 (3H, s, Ac), 2.18 (3H, s, Ac), 5.24 (1H, d,  $J=2.5$  Hz, H-1), 5.66 (1H, m, H-4), 5.75 (1H, d,  $J=16.18$  Hz, H-1'), 5.82 (1H, d,  $J=2.5$  Hz, H-2), 6.15 (1H, d,  $J=16.18$  Hz, H-2').

### 3.3. Acremine F from 1a

Acremine A **1a** (10 mg) dissolved in MeOH (4 mL) was reduced with NaBH<sub>4</sub>; after 5 min the reaction was acidified and extracted with EtOAc. The organic layers were dried and evaporated under reduced pressure to obtain a crude product that was purified by PLC (eluent: CH<sub>2</sub>Cl<sub>2</sub>/MeOH; 9:1) to afford a main compound with a <sup>1</sup>H NMR identical with that of acremine E.

**3.3.1. Compound 6.** 4-Acetoxy-6*R*-hydroxy-3-(*E*-3'-hydroxy-3'-methyl-but-1-enyl)-6-methyl-cyclohex-3-enone. Acremine B (15 mg) was treated with a mixture of Ac<sub>2</sub>O/Zn with stirring at rt for 10 min. PLC of the residue gave **6**. Oil. <sup>1</sup>H NMR (CDCl<sub>3</sub>) δ: 1.33 (6H, s, H-4'), 1.49 (3H, s, H-1''), 2.21 (3H, s, Ac), 2.65 (1H, d,  $J=17.35$  Hz, H-5), 2.85 (1H, d,  $J=17.35$  Hz, H-5), 3.14 (1H, d,  $J=20$  Hz, H-2), 3.25 (1H, d,  $J=20$  Hz, H-2), 5.68 (1H, d,  $J=15.76$  Hz, H-1'), 6.44 (1H, d,  $J=15.76$  Hz, H-2'); <sup>13</sup>C NMR (CDCl<sub>3</sub>) δ: 18.2 (Ac), 20.7 (C-1''), 29.9 (C-4'), 35.6 (C-2), 42.7 (C-5), 71.0 (C-3'), 74.68 (C-6), 119.0 (C-3), 120.9 (C-1'), 132.3 (C-2'), 141.4 (C-4), 168.9 (Ac), 209 (C-1).

### 3.4. X-ray crystallographic study of Acremine 1a

The compound crystallises in the monoclinic system, *P*2(1) space group, with cell parameters:  $a=5.829(1)$  Å,  $b=8.890(1)$  Å,  $c=11.695(1)$  Å,  $\beta=97.980(1)^\circ$ ,  $V=600.2(1)$  Å<sup>3</sup>,  $Z=2$ ,  $D_c=1.252$  g cm<sup>-3</sup>,  $F(000)=244$ . The crystal suitable for X-ray analysis, with approximate dimensions of 0.4×0.5×0.01 mm<sup>3</sup>, was obtained upon slow crystallisation from acetone. Intensities data were collected, at rt, on a Siemens P4 diffractometer with graphite monochromated Cu Kα radiation ( $\lambda=1.54179$  Å), using  $\theta/2\theta$  scan technique, voltage 40 kV, current 40 mA. Unit cell parameters were determined using 61 reflections in the

range  $12.50 \leq 2\theta \leq 76.3^\circ$ . A total of 2383 reflections (1265 unique,  $R_{\text{int}}=0.094$ ) were collected up to  $136^\circ$  in  $2\theta$  and index range:  $-5 \leq h \leq 6$ ,  $-1 \leq k \leq 10$ ,  $-14 \leq l \leq 14$ . Three standard reflections, monitored every 100 reflections, showed no intensity decay. No empirical adsorption correction was deemed necessary. The structure was solved by direct method using SIR97 program<sup>14</sup>, which revealed the position of all non-H-atoms. The refinement was carried out on  $F^2$  by full-matrix least-squares procedure with SHELXL97<sup>15</sup> for 158 parameters, with anisotropic temperature factors for non-H atoms. The final stage converged to  $R=0.0392$  ( $R_w=0.092$ ) for 1260 observed reflections (with  $I \geq 2\sigma(I)$ ), and  $R=0.0393$  ( $R_w=0.092$ ) for all unique reflections. H atoms, except the carboxyl H atom, which was freely refined with individual isotropic temperature factors, were placed in geometrically calculated positions and refined in a riding model. The data set included some Friedel-related reflections, but due to the absence in the molecule of atoms heavier than oxygen, the absolute configuration could not be reliably established. The absolute configuration was therefore chosen with respect to known chirality obtained with the Mosher's method. However, the refinement of the Flack parameter<sup>16</sup> led to a non-inconsistent value:  $x$  equal to 0.2(2) for the selected configuration and  $x$  equal to 0.6(2) for the opposite one.

Crystallographic data (excluding structure factors) for the structure reported in this paper, have been deposited at the Cambridge Crystallographic Data Centre as supplementary publication No. CCDC 272418. Copies of the data can be obtained, free of charge, on application to the CCDC, 12 Union Road, Cambridge CB21Ez, UK (fax: +44 12233336033 or e-mail: deposit@ccdc.cam.ac.uk).

### 3.5. Biological assay

Acremines A–D were assayed at 1, 0.5 and 0.1 mM as inhibitors of the germinability of *P. viticola* sporangia in 96-well flat bottom plates (Sigma-Aldrich). Metabolites were dissolved in dimethylsulfoxide, not exceeding 0.3% the final volume, and then diluted in sterile distilled water.

A suspension of *P. viticola* sporangia was freshly prepared by shaking infected leaves in distilled sterile water. The fresh suspension was immediately added 1:1 to the metabolite solutions already distributed in the microtitre plate (final volume 200  $\mu\text{L}$  each well). Controls were represented by water and DMSO in water (0.3% v/v). The plate was maintained at 22 °C for 2 h, then germination of sporangia was halted by staining the suspension with 0.05% trypan blue in Amman's lactophenol. Germinability of sporangia was determined by scoring 1200 sporangia for each metabolite at concentration tested, by means of light microscopy.

Percent of germination was compared with those obtained in the controls from the means of two independent experiments. Statistical analysis was performed using Duncan's Multiple Range Test at  $P=0.05$  (Mstat-C version 2.00, Michigan State University). The results are presented in Table 2.

**Table 2.** Inhibition of *P. viticola* sporangia germination by acremine A–D

Germinability % inhibition <sup>a</sup>	Metabolite concentration		
	0.1 mM	0.5 mM	1 mM
Acremine A	40.9 $\pm$ 1.1	44.6 $\pm$ 0.7	58.2 $\pm$ 0.4
Acremine B	31.1 $\pm$ 0.7	40.7 $\pm$ 0.8	57.7 $\pm$ 1.9
Acremine C	31.7 $\pm$ 1.1	60.5 $\pm$ 1.5	99.8 $\pm$ 0.1
Acremine D	24.5 $\pm$ 0.9	48.4 $\pm$ 1.1	59.2 $\pm$ 0.9
Water	10.3 $\pm$ 0.6		
DMSO	16.3 $\pm$ 0.4		

<sup>a</sup> Means  $\pm$  standard deviation.

### Acknowledgements

This work was in part supported by a Grant of MIUR-FIRB (Italy).

### References and notes

- Part 64 in the series 'Secondary Mould Metabolites'. For part 63 see: Nasini, G.; Arnone, A.; Assante, G.; Bava, A.; Moricca, S.; Ragazzi, A. *Phytochemistry* **2004**, *63*, 2107–2111.
- Burruano, S.; Lo Piccolo, S.; Alfonso, A.; Torta, L. *Micologia Italiana* **2004**, *23*, 42–45.
- Adinaryana, K.; Prabhakar, T.; Srinivasulu, V.; Rao, M. A.; Lakshmi, P.; Ellaiah, P. *Process. Biochem.* **2003**, *39*, 171–177.
- Moussaif, M.; Jacques, P.; Schaarwachter, P.; Budzikiewicz, H.; Thonart, P. *Appl. Environ. Microbiol.* **1997**, *63*, 1739–1743.
- Gatenbay, W. A.; Munday-Finch, S. C.; Wilkins, A. L.; Miles, C. O. *J. Agric. Food Chem.* **1999**, *47*, 1092–1097.
- Lindsey, C. C.; Gomes-Diaz, C.; Villalba, J. M.; Pettus, T. R. R. *Tetrahedron* **2002**, *58*, 4559–4565.
- Schulz, B.; Boyle, C.; Draeger, S.; Roemmert, A.-K.; Krohn, K. *Mycol. Res.* **2002**, *106*, 996–1004.
- Cheeke, P. R. *Natural Toxicants in Feeds, Forages, and Poisonous Plants*, 2nd ed.; Interstate: Danville, USA, 1998.
- Allen, F. H.; Kennard, O.; Watson, D. G.; Brammer, L.; Orpen, A. G.; Taylor, R. *J. Chem. Soc., Perkin Trans. 2* **1987**, 1–19.
- Cremer, D.; Pople, J. A. *J. Am. Chem. Soc.* **1975**, *97*, 1354–1358.
- Ohtani, I.; Kusumi, T.; Ishitsuku, M. O.; Kakisawa, H. *Tetrahedron Lett.* **1989**, *30*, 3147–3150.
- Lutz, R. E.; Bauer, C. R. *J. Am. Chem. Soc.* **1951**, *73*, 3456–3458.
- Abdel-Lateff, A.; Koenig, G. M.; Fisch, K. M.; Hoeller, U.; Jones, P. G.; Wright, A. D. *J. Nat. Prod.* **2002**, *65*, 1605–1611.
- Altomare, A.; Burla, M. C.; Camalli, M.; Cascarano, G. L.; Giacobozzo, C.; Guagliardi, A.; Moliterni, A. G. G.; Polidori, G. P.; Spagna, R. *J. Appl. Crystallogr.* **1999**, *32*, 115–119.
- Sheldrick, G. M. *SHELXL-97: Program for the Refinement of Crystal Structures*; University of Goettingen: Germany, 1997.
- Flack, H. D. *Acta Crystallogr., Sect. A* **1983**, *39*, 876–881.

# Synthesis of 3-acetyl- and 3-(2-oxoethyl)glutarates

Mercedes Amat, Oriol Bassas, Margalida Cantó, Núria Llor, Maria M. M. Santos and Joan Bosch\*

Laboratory of Organic Chemistry, Faculty of Pharmacy, University of Barcelona, 08028 Barcelona, Spain

Received 21 April 2005; accepted 26 May 2005

Available online 15 June 2005

**Abstract**—Several synthetic routes to 3-acetyl- and 3-(2-oxoethyl)glutarates **1–5** have been explored. The most advantageous involves, as the key steps, the conjugate addition of an appropriately substituted vinylmagnesium bromide to an alkylidenemalononic ester, a bis-homologation of the resulting diester and, finally, the reductive ozonolysis of the carbon–carbon double bond. The synthesis can be satisfactorily conducted in good overall yield on a multigram scale.

© 2005 Elsevier Ltd. All rights reserved.

## 1. Introduction

Some glutaric esters bearing a functionalized carbon chain (e.g., acetyl, 1-cyanopropyl) at the 3-position have classically been used as building blocks for the synthesis of indolo[2,3-*a*]- and benzo[*a*]quinolizidine alkaloids.<sup>1</sup>

In recent work, we have reported<sup>2</sup> the use of prochiral or racemic 3-substituted glutarates **1–5** (Fig. 1) as the substrates in highly enantioselective cyclocondensation reactions with chiral aminoalcohols, leading to enantiopure bicyclic lactams. These processes involve the desymmetrization of two enantiotopic (from **1** and **3**) or diastereotopic (from **2**, **4**, and **5**) acetate chains, in the latter case with a simultaneous dynamic kinetic resolution<sup>3</sup> (DKR) that promotes the epimerization of the configurationally labile stereocenter  $\alpha$  to the aldehyde or ketone carbonyl group. This methodology provides straightforward access to polysubstituted enantiopure piperidines.

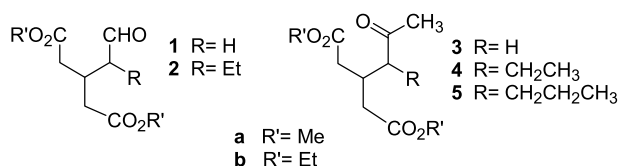


Figure 1. Target  $\delta$ -oxodiester.

**Keywords:**  $\delta$ -Oxodiester; 3-Acetylglutarate; 3-(2-Oxoethyl)glutarate; Bis-homologation; Ozonolysis; Conjugate addition.

\* Corresponding author. Tel.: +34 93 4024538; fax: +34 93 4024539; e-mail: joanbosch@ub.edu

With the exception of ketodiester **3b**, for which a convenient preparation has already been reported,<sup>4</sup> there are no precedents for the synthesis of 3-substituted glutarates **1–5**. We report here our synthetic efforts directed to the preparation of these  $\delta$ -oxodiester, culminating in the development of a general, high-yield synthetic route that can be conducted on a multigram scale.

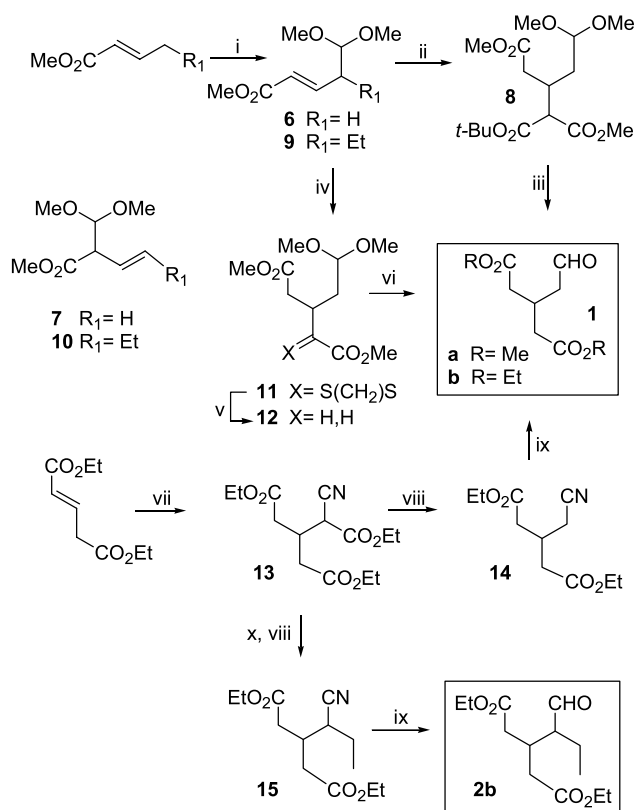
## 2. Results

For the synthesis of aldehyde diester **1a** we initially planned to start from  $\alpha,\beta$ -unsaturated ester **6**, which was prepared in 35% yield from methyl crotonate following a previously reported procedure<sup>5</sup> (Scheme 1).

Conjugate addition of *tert*-butyl methyl malonate to **6**, followed by treatment of the resulting triester **8** with TFA in the presence of thioanisole,<sup>6</sup> and subsequent heating in refluxing toluene, led to the target ester **1a** in 46% overall yield. This sequence could not be extended to the preparation of the ethyl substituted analogue **2a** since the conjugate addition of malonate esters to  $\alpha,\beta$ -unsaturated ester **9**, which was prepared as in the above deethyl series from methyl-2-hexenoate, was unsuccessful.<sup>7</sup>

Alternatively, **1a** was prepared from **6** by conjugate addition of the lithium salt derived from methyl 1,3-dithiolane-2-carboxylate, followed by nickel boride desulfurization and chemoselective hydrolysis of the acetal function with  $\text{LiBF}_4$  in wet acetonitrile.<sup>8</sup> The overall yield of this three-step sequence was 39%.

The main drawback of the above approaches was the



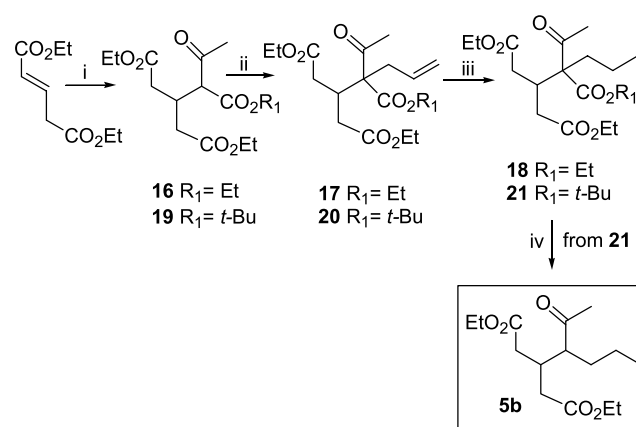
**Scheme 1.** Reagents: (i) **6**: see Ref. 5, 35%; **9**: LDA, HMPA, Me<sub>3</sub>SiCl, then ZnBr<sub>2</sub>, HC(OMe)<sub>3</sub>; (ii) NaH, *t*-BuO<sub>2</sub>CCH<sub>2</sub>CO<sub>2</sub>Me; (iii) TFA, C<sub>6</sub>H<sub>5</sub>SMe, then toluene, reflux; (iv) LDA, methyl 1,3-dithiolane-2-carboxylate; (v) NiCl<sub>2</sub>·6H<sub>2</sub>O, NaBH<sub>4</sub>; (vi) LiBF<sub>4</sub>, MeCN, 2% H<sub>2</sub>O; (vii) See Refs. 1a, d, 85%; (viii) LiCl, DMSO, H<sub>2</sub>O; (ix) Raney-Ni, NaH<sub>2</sub>PO<sub>2</sub>; (x) See Refs. 1a,d.

moderate yield and regioselectivity in the preparation of **6**, since the  $\alpha$ -addition product **7** was also formed to a considerable extent.

The ethyl ester analog **1b** was prepared from the known intermediate **13**, which was easily accessible by Michael condensation of diethyl glutarate with ethyl cyanoacetate.<sup>1a,d</sup> Selective hydrolysis-decarboxylation of **13** under Krapcho conditions,<sup>9</sup> followed by controlled Raney Ni reduction<sup>10</sup> of the resulting nitrile **14** gave  $\delta$ -oxodiester **1b**. A similar reduction was used to obtain the ethyl substituted aldehyde diester **2b** from the known nitrile **15**, although in moderate yield. This nitrile was prepared in excellent yield by alkylation of **13** as previously reported,<sup>1a,d</sup> followed by hydrolysis-decarboxylation under Krapcho conditions.<sup>9</sup>

An important limitation of the above routes involving the controlled reduction of a cyano function is that the yield of the reduction step was somewhat erratic, leading to mixtures of the desired aldehydes **1b** and **2b** with the respective starting nitriles, which were difficult to separate.

The synthesis of the ethyl substituted ketodiester **4b** was initially attempted by a route similar to that previously employed for the preparation of **15**. The required  $\beta$ -ketoester **16** was obtained in 62% yield by Michael addition of ethyl acetylacetate to diethyl glutarate<sup>11</sup>



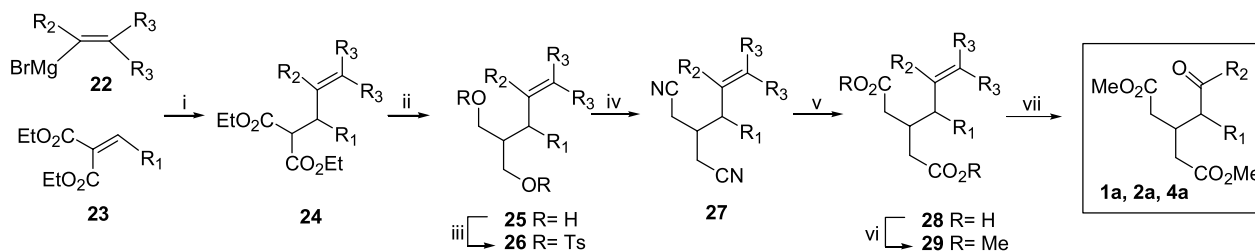
**Scheme 2.** Reagents: (i) NaOEt or *t*-BuOK, CH<sub>3</sub>COCH<sub>2</sub>CO<sub>2</sub>R<sub>1</sub>, EtOH or *t*-BuOH; (ii) DBU, Pd(acac)<sub>2</sub>, Ph<sub>3</sub>P, allyl acetate; (iii) H<sub>2</sub>, Pd-C; (iv) TFA, C<sub>6</sub>H<sub>5</sub>SMe, then toluene, reflux.

(Scheme 2). However, alkylation of **16** with ethyl iodide under a variety of conditions resulted in failure. Also unsuccessful were the attempts to directly prepare the alkylated product by Michael addition of ethyl 2-ethyl-3-oxobutanoate to diethyl glutarate.

In contrast, satisfactorily, **16** underwent a Pd-catalyzed C-allylation by treatment with allyl acetate.<sup>12</sup> Catalytic hydrogenation of the resulting product **17** gave the propyl substituted derivative **18**. However, the difficulties encountered in the deethoxycarbonylation of **18** prompted us to develop a similar sequence starting from *tert*-butyl acetylacetate. Thus, triester **19** was prepared in 74% yield,<sup>13</sup> allylated to **20** (69%), and then hydrogenated to give **21** (73%). Removal of the *tert*-butoxycarbonyl group with TFA and thioanisole<sup>6</sup> led to the propyl substituted ketodiester **5b** in 86% yield.

Although racemic ketodiester **5b** was a suitable substrate to study cyclocondensation reactions involving tandem DKR-dia stereoselective differentiation processes,<sup>2</sup> the scope of the above synthetic route is quite limited as a consequence of the need to introduce an allyl group on  $\beta$ -ketoester moiety of **16** or **19**. For this reason, and also taking into account the inconveniences of the synthetic routes depicted in Scheme 1, we designed a new synthetic route that could provide general access to 3-(2-oxoethyl)- and 3-acetylglutarates. It involves the introduction of an alkene moiety as a latent form of the aldehyde or ketone carbonyl group by conjugate addition<sup>14</sup> of an appropriately substituted vinylmagnesium bromide **22** to an alkylidenemalonate **23**, a bis-homologation of the resulting diester and, finally, the reductive ozonolysis of the carbon-carbon double bond (Scheme 3).

To check the viability of this synthetic route we considered the synthesis of the ethyl substituted ketone **4a**, which had been inaccessible by the route depicted in Scheme 2. Conjugate addition of isopropenylmagnesium bromide (**22**; R<sub>2</sub> = Me, R<sub>3</sub> = H) to diethyl propylidenemalonate (**23**; R<sub>1</sub> = Et) in the presence of CuCl gave the malonic ester derivative **24a** in 70% yield. LiAlH<sub>4</sub> reduction, followed by tosylation of the resulting diol **25a** and subsequent substitution of tosylate **26a** with NaCN gave dinitrile **27a**,



**Scheme 3.** Reagents and conditions: (i) CuCl; (ii) LiAlH<sub>4</sub>; (iii) KOH, TsCl; (iv) NaCN; (v) 35% aq. NaOH, MeOH, then 6 N HCl; (vi) Me<sub>3</sub>ClSi; (vii) O<sub>3</sub>, Me<sub>2</sub>S.

**Table 1.** Synthesis of the target  $\delta$ -oxodiester

Compound	R <sub>1</sub>	R <sub>2</sub>	R <sub>3</sub>	24 (%)	25 (%)	26 (%)	27 (%)	28 (%)	29 (%)	1a, 2a, 4a (%)
<b>a</b>	Et	Me	H	70	93	87	90	90	91	65 (4a: R <sub>1</sub> =Et; R <sub>2</sub> =Me)
<b>b</b>	Et	H	Me	74	94	88	90	82	92	64 (2a: R <sub>1</sub> =Et, R <sub>2</sub> =H)
<b>c</b>	Et	H	H	92	97	88	88	95	92	75 (2a: R <sub>1</sub> =Et, R <sub>2</sub> =H)
<b>d</b>	H	H	H	—	71	96	91	92	88	84 (1a: R <sub>1</sub> =R <sub>2</sub> =H)

which was then converted to diester **29a** via diacid **28a**. This bis-homologation sequence from **24a** took place in 60% overall yield. Finally, reductive ozonolysis of **29a** led to the target  $\delta$ -oxodiester **4a** in 65% yield.

A similar reaction sequence allowed us to prepare aldehyde diester **2a**, following two alternative routes (Table 1). Initially, we started from the malonic ester derivative **24b**, which was obtained in 74% yield by conjugate addition of 2-methyl-1-propenylmagnesium bromide (**22**; R<sub>2</sub>=H, R<sub>3</sub>=Me) to diethyl propylidene malonate (**23**; R<sub>1</sub>=Et). However, the yields of both the conjugate addition reaction and the final ozonolysis step were improved starting from vinylmagnesium bromide (**22**; R<sub>2</sub>=R<sub>3</sub>=H): diester **24c** was obtained in 92% yield, and the overall yield for the seven-step sequence leading to **2a** was 45%. The synthesis can be satisfactorily conducted on a 50–100 g scale and most of the steps take place in excellent yield.

Illustrating the general scope of the above route, aldehyde diester **1a** was satisfactorily obtained in 42% overall yield from the commercially available malonic ester derivative **24d**, via the known intermediates **25d–29d**.<sup>15</sup> In this series ozonolysis of the alkene moiety took place in 84% yield.

In conclusion, the synthetic sequence depicted in Scheme 3 provides a general, high yield route for the preparation of diversely substituted 3-(2-oxoethyl)- and 3-acetylglutarates on a multigram scale.

### 3. Experimental

#### 3.1. General experimental procedures

Melting points were determined in a capillary tube on a Büchi apparatus and are uncorrected. NMR spectra were recorded at 200, 300 or 400 MHz (<sup>1</sup>H) and 50.3, 75 or 100.6 MHz (<sup>13</sup>C), and chemical shifts are reported in  $\delta$  values downfield from TMS. Only noteworthy IR absorptions are listed. Thin-layer chromatography (TLC) was done on SiO<sub>2</sub> (silica gel 60 F<sub>254</sub>), and the spots were located with aqueous potassium permanganate solution or with

iodoplatinate reagent. Column chromatography was carried out using the flash chromatography technique. All non-aqueous reactions were performed under an inert atmosphere. Solvents for chromatography were distilled at atmospheric pressure prior to use and dried following standard procedures. Drying of the organic extracts during the workup of reactions was performed over anhydrous Na<sub>2</sub>SO<sub>4</sub> or MgSO<sub>4</sub>. Evaporation of solvents was accomplished with a rotatory evaporator. Microanalyses and HRMS were performed by Centre D'Investigació i Desenvolupament (CSIC), Barcelona and Unidade de Espectrometria de Masas, Santiago de Compostela.

**3.1.1. Dimethyl 2-(tert-butoxycarbonyl)-3-(2,2-dimethoxyethyl)glutarate (8).** *tert*-Butyl methyl malonate (762 mg, 4.38 mmol) and ester **6**<sup>5</sup> (504 mg, 2.9 mmol) were added to a cooled (0 °C) suspension of NaH (55% in oil dispersion, 23 mg, 0.58 mmol) in anhydrous THF (30 mL). The mixture was heated at reflux until disappearance of the starting compound was observed by TLC. The reaction was quenched with brine at 0 °C, and the aqueous phase was extracted with EtOAc. The combined organic extracts were dried and concentrated. Column chromatography (gradient of eluents hexane/EtOAc) of the residue afforded triester **8** (540 mg, 80%): IR (film) 1736 cm<sup>-1</sup>; <sup>1</sup>H NMR (CDCl<sub>3</sub>, 300 MHz)  $\delta$  1.45 (s, 9H, CCH<sub>3</sub>), 1.79 (m, 2H, CH<sub>2</sub>CHO), 2.59 (m, 2H, 2H-4), 2.72 (m, 1H, H-3), 3.30 (s, 6H, OCH<sub>3</sub>), 3.60 (dd, *J*=5.7, 1.9 Hz, 1H, H-2), 3.68 (s, 3H, CO<sub>2</sub>CH<sub>3</sub>), 3.72 (s, 3H, CO<sub>2</sub>CH<sub>3</sub>), 4.46 (t, *J*=5.4 Hz, 1H, CHOCH<sub>3</sub>); <sup>13</sup>C NMR (CDCl<sub>3</sub>, 75.4 MHz)  $\delta$  27.8 (CH<sub>3</sub>), 31.2 (CH), 34.2 (CH<sub>2</sub>), 35.8 (CH<sub>2</sub>), 51.5 (CH<sub>3</sub>), 52.1 (CH<sub>3</sub>), 52.5 (CH<sub>3</sub>), 52.9 (CH<sub>3</sub>), 54.8 (CH), 82.1 (C), 103.0 (CH), 167.3 (C), 169.1 (C), 172.6 (C).

**3.1.2. Methyl 4-(dimethoxymethyl)-2-hexenoate (9).** A solution of methyl 2-hexenoate<sup>5</sup> (1 g, 7.8 mmol) in anhydrous THF (2 mL) was slowly added to a cooled (−78 °C) solution of LDA (1.5 M in THF, 7.8 mmol) and HMPA (1.6 mL, 9.36 mmol) in anhydrous THF (6 mL), and the resulting mixture was stirred for 30 min at this temperature. Then, a solution of Me<sub>3</sub>SiCl (1.55 mL, 12.2 mmol) in anhydrous THF (2 mL) was slowly added, and the stirring was continued at room temperature for 2 h.

The mixture was diluted with pentane, washed with brine, dried, filtered, and concentrated. The ketene acetal obtained was dissolved in anhydrous  $\text{CH}_2\text{Cl}_2$  (10 mL) and stirred in presence of anhydrous  $\text{ZnBr}_2$  (1.75 g, 7.8 mmol) and anhydrous methyl orthoformate (2.6 mL, 23.4 mmol) at room temperature for 16 h. The crude mixture was poured into brine and extracted with EtOAc. The organic extracts were dried, filtered, and concentrated. Flash chromatography (hexane) of the residue afforded compounds **9** (230 mg, 15%) and **10** (460 mg, 30%). **9**: IR (film)  $1727\text{ cm}^{-1}$ ;  $^1\text{H}$  NMR ( $\text{CDCl}_3$ , 300 MHz)  $\delta$  0.86 (t,  $J=7.5$  Hz, 3H, H-6), 1.37 (ddd,  $J=15.0, 9.6, 7.5$  Hz, 1H, H-5), 1.67 (tdd,  $J=15.0, 7.5, 3.9$  Hz, 1H, H-5), 2.41 (ddd,  $J=9.6, 6.3, 2.4$  Hz, 1H, H-4), 3.34 (s, 3H,  $\text{OCH}_3$ ), 3.36 (s, 3H,  $\text{OCH}_3$ ), 3.73 (s, 3H,  $\text{CO}_2\text{CH}_3$ ), 4.25 (d,  $J=6.3$  Hz, 1H,  $\text{CHOCH}_3$ ), 5.88 (dd,  $J=15.6, 0.6$  Hz, 1H, H-2), 6.81 (dd,  $J=15.6, 9.6$  Hz, 1H, H-3);  $^{13}\text{C}$  NMR ( $\text{CDCl}_3$ , 75.4 MHz)  $\delta$  11.4 ( $\text{CH}_3$ ), 22.3 ( $\text{CH}_2$ ), 47.5 (CH), 51.4 ( $\text{CH}_3$ ), 54.0 ( $\text{CH}_3$ ), 54.3 ( $\text{CH}_3$ ), 106.1 (CH), 122.6 (CH), 147.8 (CH), 166.6 (C). HRMS calcd for  $\text{C}_{10}\text{H}_{18}\text{O}_4$  202.1202, found 202.1205. **10**: IR (film)  $1748\text{ cm}^{-1}$ ;  $^1\text{H}$  NMR ( $\text{CDCl}_3$ , 300 MHz)  $\delta$  0.98 (t,  $J=7.5$  Hz, 3H, H-6), 2.12 (ddd,  $J=15.0, 7.5, 1.5$  Hz, 1H, H-5), 3.31 (s, 3H,  $\text{OCH}_3$ ), 3.39 (s, 3H,  $\text{OCH}_3$ ), 3.69 (s, 3H,  $\text{CO}_2\text{CH}_3$ ), 3.70 (masked, 1H, H-2), 4.68 (d,  $J=7.8$  Hz, 1H,  $\text{CHOCH}_3$ ), 5.37 (dd,  $J=11.4, 1.5$  Hz, 1H, H-4), 5.64 (m, 1H, H-3);  $^{13}\text{C}$  NMR ( $\text{CDCl}_3$ , 75.4 MHz)  $\delta$  13.7 ( $\text{CH}_3$ ), 20.9 ( $\text{CH}_2$ ), 48.0 (CH), 51.8 ( $\text{CH}_3$ ), 52.8 ( $\text{CH}_3$ ), 54.7 ( $\text{CH}_3$ ), 104.2 (CH), 121.4 (CH), 136.3 (CH), 171.4 (C). HRMS calcd for  $\text{C}_{10}\text{H}_{18}\text{O}_4$  202.1202, found 202.1205.

**3.1.3. Methyl 2-[1-(methoxycarbonylmethyl)-3,3-dimethoxypropyl]-1,3-dithiolane-2-carboxylate (11).** Methyl 1,3-dithiolane-2-carboxylate (625 mg, 3.5 mmol) was added to a cooled ( $-78^\circ\text{C}$ ) solution of LDA (1.5 M in cyclohexane, 7.19 mmol) in anhydrous THF (30 mL), and the mixture was stirred for 15 min at this temperature. Then, a solution of acetal **6** (1.2 g, 7.56 mmol) in anhydrous THF (1 mL) was slowly added, and the mixture was stirred at room temperature for 4 h. The mixture was poured into brine, the aqueous layer was extracted with EtOAc, and the combined organic extracts were dried and concentrated. Flash chromatography of the resulting yellow oil (8:2 hexane/EtOAc) afforded pure compound **11** (1.1 g, 95%): IR (film)  $1737\text{ cm}^{-1}$ ;  $^1\text{H}$  NMR ( $\text{CDCl}_3$ , 300 MHz)  $\delta$  1.65 (ddd,  $J=14.1, 10.1, 6.0$  Hz, 1H, H-4), 1.84 (ddd,  $J=14.1, 5.4, 2.9$  Hz, 1H, H-4), 2.49 (dd,  $J=16.5, 6.0$  Hz, 1H, H-2), 2.79 (dd,  $J=16.5, 4.0$  Hz, 1H, H-2), 3.13 (m, 1H, H-3), 3.28 (s, 6H,  $\text{OCH}_3$ ), 3.30–3.41 (m, 4H,  $\text{S}(\text{CH}_2)_2\text{S}$ ), 3.69 (s, 3H,  $\text{CO}_2\text{CH}_3$ ), 3.78 (s, 3H,  $\text{CO}_2\text{CH}_3$ ), 4.47 (t,  $J=5.4$  Hz, 1H,  $\text{CHOCH}_3$ );  $^{13}\text{C}$  NMR ( $\text{CDCl}_3$ , 75.4 MHz)  $\delta$  37.1 ( $\text{CH}_2$ ), 37.3 ( $\text{CH}_2$ ), 38.3 (CH), 39.8 ( $\text{CH}_2$ ), 39.9 ( $\text{CH}_2$ ), 51.6 ( $\text{CH}_3$ ), 51.9 ( $\text{CH}_3$ ), 53.3 ( $\text{CH}_3$ ), 53.6 ( $\text{CH}_3$ ), 75.9 (CH and C), 171.9 (C), 172.9 (C). HRMS calcd for  $\text{C}_{13}\text{H}_{22}\text{O}_6\text{S}_2$  338.0859, found 338.0857.

**3.1.4. Dimethyl 3-(2,2-dimethoxyethyl)glutarate (12).** Compound **11** (900 mg, 2.6 mmol) was dissolved in a mixture of MeOH/THF (2:1, 7.5 mL) at  $0^\circ\text{C}$ . Then,  $\text{NiCl}_2 \cdot 6\text{H}_2\text{O}$  (5 g, 18.2 mmol) and  $\text{NaBH}_4$  (2 g, 54.2 mmol) were added, and the resulting mixture was stirred at  $0^\circ\text{C}$  for 30 min. The crude mixture was concentrated to give an oil, which was dissolved in EtOAc. The organic layer was washed with brine, dried,

filtered, and concentrated to give **12** (432 mg, 67%), which was used in the next reaction without further purification: IR (film)  $1736\text{ cm}^{-1}$ ;  $^1\text{H}$  NMR ( $\text{CDCl}_3$ , 300 MHz)  $\delta$  1.68 (t,  $J=5.9$  Hz, 2H,  $\text{CH}_2\text{CHO}$ ), 2.42–2.48 (m, 5H,  $\text{CH}(\text{CH}_2\text{CO}_2)_2$ ), 3.30 (s, 6H,  $\text{OCH}_3$ ), 3.67 (s, 6H,  $\text{CO}_2\text{CH}_3$ ), 4.45 (t,  $J=5.9$  Hz, 1H,  $\text{CHOCH}_3$ );  $^{13}\text{C}$  NMR ( $\text{CDCl}_3$ , 75.4 MHz)  $\delta$  28.3 (CH), 36.2 ( $\text{CH}_2$ ), 38.1 ( $\text{CH}_2$ ), 51.4 ( $\text{CH}_3$ ), 52.5 ( $\text{CH}_3$ ), 102.7 (CH), 172.5 (C).

**3.1.5. Diethyl 3-(cyanomethyl)glutarate (14).** Triester **13**<sup>1a,d</sup> (391 mg, 1.30 mmol) and LiCl (61 mg, 1.43 mmol) were dissolved in DMSO (2 mL) containing a few drops of  $\text{H}_2\text{O}$ , and the mixture was stirred at  $140^\circ\text{C}$  for 4 h. Then the mixture was cooled, dissolved in EtOAc, and washed with  $\text{H}_2\text{O}$ . The combined organic solutions were dried, filtered, and concentrated to give an oil. Flash chromatography (1:9 hexane/EtOAc) afforded **14** (222 mg, 75%) as an oil: IR (film)  $2246, 1726\text{ cm}^{-1}$ ;  $^1\text{H}$  NMR ( $\text{CDCl}_3$ , 200 MHz)  $\delta$  1.27 (t,  $J=7.4$  Hz, 6H,  $\text{CH}_3$ ), 2.53 (d,  $J=5.2$  Hz, 4H,  $\text{CH}_2\text{CO}_2$ ), 2.66 (masked, 1H, CH), 2.68 (d,  $J=2.2$  Hz, 2H,  $\text{CH}_2\text{CN}$ ), 4.17 (q,  $J=7.4$  Hz, 4H,  $\text{OCH}_2$ );  $^{13}\text{C}$  NMR ( $\text{CDCl}_3$ , 50.3 MHz)  $\delta$  14.0 ( $\text{CH}_3$ ), 21.3 ( $\text{CH}_2$ ), 28.7 (CH), 36.9 ( $\text{CH}_2$ ), 60.7 ( $\text{CH}_2$ ), 117.6 (C), 170.8 (C).

**3.1.6. Diethyl 3-(1-cyanopropyl)glutarate (15).** Compound **13** was ethylated following a previously reported procedure.<sup>1a,d</sup> The product (219 mg, 0.73 mmol), was treated with LiCl (34 mg, 0.80 mmol) in DMSO (2 mL) containing a few drops of  $\text{H}_2\text{O}$ , as in the above diethyl series, to give pure **15** (85 mg, 74%) after flash chromatography (EtOAc): IR (film)  $2978, 1736\text{ cm}^{-1}$ ;  $^1\text{H}$  NMR ( $\text{CDCl}_3$ , 300 MHz)  $\delta$  1.15 (t,  $J=7.2$  Hz, 3H,  $\text{CH}_3$ ), 1.27 (t,  $J=7.0$  Hz, 6H,  $\text{CH}_3$ ), 1.66 (qd,  $J=7.2, 2.3$  Hz, 2H,  $\text{CH}_2$ ), 2.40–2.58 (m, 4H, H-2 and H-4), 2.60 (m, 1H,  $\text{CHCN}$ ), 2.88 (ddd,  $J=8.4, 6.3, 4.2$  Hz, 1H, H-3), 4.16 (qd,  $J=7.0, 2.1$  Hz, 4H,  $\text{OCH}_2$ );  $^{13}\text{C}$  NMR ( $\text{CDCl}_3$ , 75.4 MHz)  $\delta$  12.0 ( $\text{CH}_3$ ), 14.0 ( $\text{CH}_3$ ), 23.3 ( $\text{CH}_2$ ), 33.0 (CH), 35.1 ( $\text{CH}_2$ ), 36.5 ( $\text{CH}_2$ ), 36.9 (CH), 60.7 ( $\text{CH}_2$ ), 60.8 ( $\text{CH}_2$ ), 120.0 (C), 171.2 (C), 171.3 (C).

**3.1.7. Diethyl 2-acetyl-3-(ethoxycarbonylmethyl)glutarate (16).** Ethyl acetylacrylate (22 g, 0.16 mmol) and a 0.57 M solution of NaOEt in EtOH (5 mL) were added to a solution of diethyl glutaconate (10 mL, 0.05 mmol) in absolute EtOH (20 mL), and the mixture was heated at reflux for 4 h. Then, 0.57 M NaOEt (5 mL) was added at intervals of 14, 8 and 14 h. After 6 h of additional reflux, concentrated AcOH (2 mL) was added, and the mixture was evaporated. The brown residue was dissolved in  $\text{Et}_2\text{O}$ , and the organic solution was exhaustively washed with  $\text{NaHCO}_3$  and brine, dried, and evaporated to give an oil. Purification by fractional distillation ( $150^\circ\text{C}$ , 1 mmHg) gave triester **16** (11 g, 62%): IR (film)  $1736, 1657\text{ cm}^{-1}$ ;  $^1\text{H}$  NMR ( $\text{CDCl}_3$ , 300 MHz)  $\delta$  1.25 (t,  $J=7.2$  Hz, 6H,  $\text{CH}_3$ ), 1.26 (t,  $J=7.2$  Hz, 3H,  $\text{CH}_3$ ), 2.27 (s, 3H,  $\text{COCH}_3$ ), 2.47 (dd,  $J=16.5, 7.5$  Hz, 1H,  $\text{CH}_2\text{CO}$ ), 2.49 (dd,  $J=16.5, 4.5$  Hz, 1H,  $\text{CH}_2\text{CO}$ ), 2.54 (dd,  $J=4.5, 6.3$  Hz, 1H,  $\text{CH}_2\text{CO}$ ), 2.59 (dd,  $J=16.5, 1.8$  Hz, 1H,  $\text{CH}_2\text{CO}$ ), 3.05 (ddt,  $J=13.0, 6.9, 1.8$  Hz, 1H, H-3), 3.93 (d,  $J=6.9$  Hz, 1H, H-2), 4.11 (q,  $J=7.2$  Hz, 4H,  $\text{OCH}_2$ ), 4.16 (q,  $J=7.2$  Hz, 2H,  $\text{OCH}_2$ );  $^{13}\text{C}$  NMR ( $\text{CDCl}_3$ , 75.4 MHz)  $\delta$  13.8 ( $\text{CH}_3$ ), 13.9 ( $\text{CH}_3$ ), 29.9 ( $\text{CH}_3$ ), 30.7 (CH), 35.2 ( $\text{CH}_2$ ), 35.5 ( $\text{CH}_2$ ), 60.4 ( $\text{CH}_2$ ), 60.5

(CH<sub>2</sub>), 61.3 (CH<sub>2</sub>), 61.5 (CH), 168.3 (C), 171.7 (C), 202.2 (C). HRMS calcd for C<sub>15</sub>H<sub>24</sub>O<sub>7</sub> 316.1526, found 316.1522.

**3.1.8. Diethyl 2-acetyl-2-allyl-3-(ethoxycarbonylmethyl)glutarate (17).** DBU (1.3 mL, 8.7 mmol), Pd(acac)<sub>2</sub> (132 mg, 0.4 mmol), Ph<sub>3</sub>P (457 mg, 1.7 mmol), and allyl acetate (1.4 mL, 13.5 mmol) were added to a solution of triester **16** (2.6 g, 8.7 mmol) in anhydrous toluene (43 mL), and the resulting mixture was heated at reflux for 6 h. The solvent was eliminated under reduced pressure, and the residue was dissolved in EtOAc. The organic extract was washed with aqueous 2 N HCl, dried, filtered, and concentrated to give a brown oil (3.7 g). Flash chromatography (hexane) afforded **17** (1.89 g, 64%) as a transparent oil: IR (film) 1639, 1735 cm<sup>-1</sup>; <sup>1</sup>H NMR (CDCl<sub>3</sub>, 300 MHz) δ 1.25 (t, *J*=7.2 Hz, 6H, CH<sub>3</sub>), 1.27 (t, *J*=7.2 Hz, 3H, CH<sub>3</sub>), 2.18 (s, 3H, COCH<sub>3</sub>), 2.30 (dd, *J*=16.0, 8.4 Hz, 1H, CH<sub>2</sub>CO), 2.41 (dd, *J*=16.0, 8.4 Hz, 1H, CH<sub>2</sub>CO), 2.55 (dd, *J*=16.0, 3.9 Hz, 1H, CH<sub>2</sub>CO), 2.58 (dd, *J*=16.0, 3.9 Hz, 1H, CH<sub>2</sub>CO), 2.63 (d, *J*=10.2 Hz, 2H, CH<sub>2</sub>CH=), 3.20 (dt, *J*=6.9, 3.9 Hz, 1H, H-3), 4.12 (ddd, *J*=14.4, 7.2, 3.0 Hz, 4H, OCH<sub>2</sub>), 4.24 (ddd, *J*=14.4, 7.2, 0.6 Hz, 2H, OCH<sub>2</sub>), 55.07–5.15 (m, 2H, CH<sub>2</sub>=), 5.74 (dd, *J*=17.1, 10.2 Hz, 1H, CH=); <sup>13</sup>C NMR (CDCl<sub>3</sub>, 75.4 MHz) δ 14.0 (CH<sub>3</sub>), 14.1 (CH<sub>3</sub>), 28.2 (CH<sub>3</sub>), 34.5 (CH), 35.8 (CH<sub>2</sub>), 36.7 (CH<sub>2</sub>), 36.9 (CH<sub>2</sub>), 60.5 (CH<sub>2</sub>), 60.6 (CH<sub>2</sub>), 61.5 (CH<sub>2</sub>), 66.3 (C), 119.1 (CH<sub>2</sub>=), 132.3 (CH=), 170.7 (C), 171.8 (C), 172.1 (C), 204.0 (C).

**3.1.9. Diethyl 2-acetyl-3-(ethoxycarbonylmethyl)-2-propylglutarate (18).** Pd-C (10%, 125 mg) was added to a solution of **17** (500 mg, 1.4 mmol) in MeOH (28 mL), and the resulting suspension was hydrogenated at atmospheric pressure for 4 h. The catalyst was removed by filtration, and the solution was concentrated to give **18** as an oil (430 mg, 85%), which was used in the next reaction without further purification: IR (film) 1709, 1736 cm<sup>-1</sup>; <sup>1</sup>H NMR (CDCl<sub>3</sub>, 300 MHz) δ 0.93 (t, *J*=7.2 Hz, 3H, CH<sub>3</sub>), 1.16 (m, 2H, CH<sub>2</sub>), 1.25 (t, *J*=7.2 Hz, 6H, CH<sub>3</sub>), 1.29 (t, *J*=7.2 Hz, 3H, CH<sub>3</sub>), 1.31 (t, *J*=7.2 Hz, 2H, CH<sub>2</sub>), 2.18 (s, 3H, CH<sub>3</sub>CO), 2.27 (dd, *J*=15.6, 8.4 Hz, 1H, CH<sub>2</sub>CO), 2.33 (dd, *J*=16.5, 8.4 Hz, 1H, CH<sub>2</sub>CO), 2.53 (dd, *J*=15.6, 3.5 Hz, 1H, CH<sub>2</sub>CO), 2.62 (dd, *J*=16.5, 3.5 Hz, 1H, CH<sub>2</sub>CO), 3.18 (dt, *J*=7.2, 3.5 Hz, 1H, H-3), 4.12 (ddd, *J*=14.4, 7.2, 1.8 Hz, 4H, OCH<sub>2</sub>), 4.23 (ddd, *J*=14.4, 7.2, 1.8 Hz, 2H, OCH<sub>2</sub>); <sup>13</sup>C NMR (CDCl<sub>3</sub>, 75.4 MHz) δ 14.0 (CH<sub>3</sub>), 14.1 (CH<sub>3</sub>), 14.2 (CH<sub>3</sub>), 14.5 (CH<sub>3</sub>), 17.5 (CH<sub>2</sub>), 28.1 (CH<sub>3</sub>), 34.1 (CH), 34.6 (CH<sub>2</sub>), 35.9 (CH<sub>2</sub>), 36.8 (CH<sub>2</sub>), 60.5 (CH<sub>2</sub>), 60.6 (CH<sub>2</sub>), 61.3 (CH<sub>2</sub>), 66.1 (C), 171.2 (C), 171.9 (C), 172.2 (C), 204.6 (C).

**3.1.10. Ethyl tert-butyl 2-acetyl-3-(ethoxycarbonylmethyl)glutarate (19).** Operating as described for the preparation of **16**, compound **19** was prepared from diethyl glutaconate (9.5 mL, 0.053 mmol), *tert*-butyl acetylacetate (9.2 g, 0.058 mmol), and 1 M *t*-BuOK in *t*-BuOH (5 mL) in anhydrous *t*-BuOH (11 mL). After fractionated distillation (150 °C, 1 mmHg), a mixture (16 g) of ketotriester **19** and starting material was obtained. Flash chromatography (hexane) afforded **19** (13.7 mg, 74%) as a transparent oil: IR (film) 1737 cm<sup>-1</sup>; <sup>1</sup>H NMR (CDCl<sub>3</sub>, 300 MHz) δ 1.24 (t, *J*=7.5 Hz, 6H, CH<sub>3</sub>), 1.95 (s, 9H, CH<sub>3</sub>), 2.25 (s, 3H, CH<sub>3</sub>CO), 2.39–2.61 (m, 4H, CH<sub>2</sub>CO), 3.0 (m, 1H, H-3),

3.80 (d, *J*=7.0 Hz, 1H, H-2), 4.13 (q, *J*=7.5 Hz, 4H, OCH<sub>2</sub>); <sup>13</sup>C NMR (CDCl<sub>3</sub>, 75.4 MHz) δ 14.0 (CH<sub>3</sub>), 27.9 (CH<sub>3</sub>), 29.9 (CH<sub>3</sub>), 30.7 (CH), 35.2 (CH<sub>2</sub>), 35.5 (CH<sub>2</sub>), 60.3 (CH<sub>2</sub>), 61.5 (CH), 82.3 (C), 167.4 (C), 171.6 (C), 171.7 (C), 202.3 (C). HRMS calcd for C<sub>17</sub>H<sub>28</sub>O<sub>7</sub> 344.1463, found 344.1460.

**3.1.11. Ethyl tert-butyl 2-acetyl-2-allyl-3-(ethoxycarbonylmethyl)glutarate (20).** Operating as described for the preparation of **17**, pure compound **20** (470 mg, 69%) was obtained from ketotriester **19** (610 mg, 1.77 mmol) after flash chromatography (hexane): IR (film) 1709, 1736 cm<sup>-1</sup>; <sup>1</sup>H NMR (CDCl<sub>3</sub>, 300 MHz) δ 1.25 (t, *J*=7.2 Hz, 6H, CH<sub>3</sub>), 1.49 (s, 9H, CH<sub>3</sub>), 2.18 (s, 3H, CH<sub>3</sub>CO), 2.25 (dd, *J*=15.6, 8.4 Hz, 1H, CH<sub>2</sub>CO), 2.32 (dd, *J*=16.5, 9.3 Hz, 1H, CH<sub>2</sub>CO), 2.53 (dd, *J*=15.6, 3.6 Hz, 1H, CH<sub>2</sub>CO), 2.59 (d, *J*=1.8 Hz, 2H, CH<sub>2</sub>CH=), 2.63 (dd, *J*=16.5, 2.4 Hz, 1H, CH<sub>2</sub>CO), 3.19 (m, 1H, H-3), 4.12 (qd, *J*=7.2, 2.4 Hz, 4H, OCH<sub>2</sub>), 5.06–5.14 (m, 2H, CH<sub>2</sub>=), 5.75 (dd, *J*=17.1, 10.2 Hz, 1H, CH=); <sup>13</sup>C NMR (CDCl<sub>3</sub>, 75.4 MHz) δ 14.0 (CH<sub>3</sub>), 14.1 (CH<sub>3</sub>), 27.9 (CH<sub>3</sub>), 28.3 (CH<sub>3</sub>), 34.5 (CH), 36.3 (CH<sub>2</sub>), 36.9 (CH<sub>2</sub>), 37.1 (CH<sub>2</sub>), 60.5 (CH<sub>2</sub>), 60.6 (CH<sub>2</sub>), 66.8 (C), 82.8 (C), 118.8 (CH<sub>2</sub>=), 132.6 (CH=), 169.7 (C), 171.9 (C), 172.1 (C), 204.2 (C).

**3.1.12. Ethyl tert-butyl 2-acetyl-3-(ethoxycarbonylmethyl)-2-propylglutarate (21).** Operating as described for the preparation of **18**, ketotriester **21** (800 mg, 73%) was obtained from **20** (1.2 g, 3.1 mmol) after flash chromatography (hexane): IR (film) 1708, 1732 cm<sup>-1</sup>; <sup>1</sup>H NMR (CDCl<sub>3</sub>, 300 MHz) δ 0.90 (t, *J*=6.0 Hz, 3H, CH<sub>3</sub>), 1.24 (masked, 2H, CH<sub>2</sub>), 1.25 (t, *J*=7.2 Hz, 6H, CH<sub>3</sub>), 1.49 (s, 9H, CH<sub>3</sub>), 1.77 (td, *J*=11.7, 5.4 Hz, 2H, CH<sub>2</sub>), 2.18 (s, 3H, CH<sub>3</sub>CO), 2.20 (dd, *J*=15.9, 7.8 Hz, 1H, CH<sub>2</sub>CO), 2.26 (dd, *J*=16.5, 9.3 Hz, 1H, CH<sub>2</sub>CO), 2.52 (dd, *J*=15.9, 4.2 Hz, 1H, CH<sub>2</sub>CO), 2.62 (dd, *J*=16.5, 3.0 Hz, 1H, CH<sub>2</sub>CO), 3.16 (m, 1H, H-3), 4.09 (qd, *J*=7.2, 2.4 Hz, 4H, OCH<sub>2</sub>); <sup>13</sup>C NMR (CDCl<sub>3</sub>, 75.4 MHz) δ 13.0 (CH<sub>3</sub>), 14.0 (CH<sub>3</sub>), 14.5 (CH<sub>3</sub>), 17.3 (CH<sub>2</sub>), 27.8 (CH<sub>3</sub>), 28.0 (CH<sub>3</sub>), 33.9 (CH), 34.5 (CH<sub>2</sub>), 36.2 (CH<sub>2</sub>), 37.1 (CH<sub>2</sub>), 60.3 (CH<sub>2</sub>), 60.5 (CH<sub>2</sub>), 66.5 (C), 82.4 (C), 170.1 (C), 171.9 (C), 172.1 (C), 204.6 (C). HRMS calcd for C<sub>20</sub>H<sub>34</sub>O<sub>7</sub> 386.2618, found 386.2609.

**3.1.13. Ethyl 3-(ethoxycarbonylmethyl)-4-propyl-5-oxohexanoate (5b).** Thioanisole (1.9 mL) and TFA (1.5 mL, 19.9 mmol) were added to a cooled (0 °C) solution of **21** (770 mg, 1.9 mmol) in CH<sub>2</sub>Cl<sub>2</sub> (9.6 mL). The mixture was stirred at room temperature for 8 h and concentrated. The residue was dissolved in anhydrous toluene (4 mL). The resulting solution was heated at reflux for 3 h and concentrated to dryness. Flash chromatography (hexane) afforded **5b** (660 mg, 86%): IR (film) 1738 cm<sup>-1</sup>; <sup>1</sup>H NMR (CDCl<sub>3</sub>, 300 MHz) δ 0.88 (t, *J*=10.5 Hz, 3H, CH<sub>3</sub>), 1.25 (td, *J*=10.5, 6.0 Hz, 6H, CH<sub>3</sub>), 1.27 (masked, 3H, CH<sub>2</sub>CH<sub>2</sub>), 1.61 (m, 1H, CH<sub>2</sub>CH<sub>2</sub>), 2.21 (s, 3H, CH<sub>3</sub>CO), 2.26 (d, *J*=11.0 Hz, 1H, CH<sub>2</sub>CO), 2.36 (d, *J*=8.0 Hz, 1H, CH<sub>2</sub>CO), 2.39 (d, *J*=11.0 Hz, 1H, CH<sub>2</sub>CO), 2.41 (masked, 1H, H-3), 2.42 (d, *J*=8.0 Hz, 1H, CH<sub>2</sub>CO), 2.70 (m, 1H, H-4), 4.13 (q, *J*=10.5 Hz, 4H, OCH<sub>2</sub>); <sup>13</sup>C NMR (CDCl<sub>3</sub>, 75.4 MHz) δ 14.1 (CH<sub>3</sub>), 14.2 (CH<sub>3</sub>), 21.0 (CH<sub>3</sub>), 29.0 (CH<sub>2</sub>), 30.5 (CH<sub>3</sub>), 32.6 (CH), 35.1 (CH<sub>2</sub>), 36.5 (CH<sub>2</sub>), 53.8 (CH), 60.5 (CH<sub>2</sub>), 172.1 (C), 211.2 (C). HRMS calcd for C<sub>15</sub>H<sub>26</sub>O<sub>5</sub> 286.1517, found 286.1520.



**3.1.14. Diethyl 2-(1-ethyl-2-methyl-2-propenyl)malonate (24a).** Diethyl 2-propylidenemalonate<sup>16</sup> (**23**, R<sub>1</sub>=Et; 45.5 g, 0.21 mol) in anhydrous Et<sub>2</sub>O (500 mL) was added to a cooled (−78 °C) suspension of CuCl (0.41 g, 4.1 mmol) and isopropenylmagnesium bromide (**22**, R<sub>2</sub>=Me, R<sub>3</sub>=H; 0.5 M in THF, 500 mL, 0.25 mol), and the mixture was stirred until the temperature was raised to 25 °C. Then saturated aqueous NH<sub>4</sub>Cl (200 mL) was added, and the aqueous layer was extracted with Et<sub>2</sub>O. The combined organic extracts were washed with brine, dried, and filtered. Flash chromatography (gradient hexane/EtOAc) afforded pure **24a** (41.3 g, 75%): IR (film) 1735 cm<sup>−1</sup>; <sup>1</sup>H NMR (CDCl<sub>3</sub>, 400 MHz, COSY, HETCOR) δ 0.82 (t, *J*=7.2 Hz, 3H, CH<sub>3</sub>), 1.22 (t, *J*=7.2 Hz, 3H, CH<sub>3</sub>), 1.27 (t, *J*=7.2 Hz, 3H, CH<sub>3</sub>), 1.30 (m, 1H, CH<sub>2</sub>), 1.50 (m, 1H, CH<sub>2</sub>), 1.68 (dd, *J*=1.5, 0.9 Hz, 3H, CH<sub>3</sub>), 2.77 (td, *J*=11.1, 3.6 Hz, 1H, CHC=), 3.42 (d, *J*=11.1 Hz, 1H, H-2), 4.12 (q, *J*=7.2 Hz, 1H, CH<sub>2</sub>O), 4.13 (q, *J*=7.2 Hz, 1H, CH<sub>2</sub>O), 4.20 (q, *J*=7.2 Hz, 2H, CH<sub>2</sub>O), 4.79 (m, 1H, =CH<sub>2</sub>), 4.85 (m, 1H, =CH<sub>2</sub>); <sup>13</sup>C NMR (CDCl<sub>3</sub>, 100.6 MHz, HETCOR) δ 11.2 (CH<sub>3</sub>), 13.9 (CH<sub>3</sub>), 14.0 (CH<sub>3</sub>), 18.7 (CH<sub>3</sub>), 23.5 (CH<sub>2</sub>), 48.4 (CH), 56.3 (CH), 61.0 (CH<sub>2</sub>), 61.2 (CH<sub>2</sub>), 114.2 (CH<sub>2</sub>), 143.2 (CH), 167.9 (C), 168.3 (C). Anal. Calcd for C<sub>13</sub>H<sub>22</sub>O<sub>4</sub>: C, 64.44; H, 9.15. Found: C, 64.37; H, 9.12.

**3.1.15. Diethyl 2-(1-ethyl-3-methyl-2-butenyl)malonate (24b).** Operating as above, pure **24b** (18.4 g, 74%) was obtained from 2-methyl-1-propenylmagnesium bromide (**22**, R<sub>2</sub>=H, R<sub>3</sub>=Me; 0.5 M in THF, 216 mL, 0.11 mol), CuCl (0.19 g, 1.8 mmol), and diethyl 2-propylidenemalonate<sup>16</sup> (**23**, R<sub>1</sub>=Et; 18.0 g, 0.09 mol) after flash chromatography (hexane, 25:1 hexane/EtOAc): IR (film) 1732 cm<sup>−1</sup>; <sup>1</sup>H NMR (CDCl<sub>3</sub>, 400 MHz, COSY, HETCOR) δ 0.83 (t, *J*=7.2 Hz, 3H, CH<sub>3</sub>), 1.15–1.21 (m, 1H, CH<sub>2</sub>), 1.22 (t, *J*=7.2 Hz, 3H, CH<sub>3</sub>), 1.26 (t, *J*=7.2 Hz, 3H, CH<sub>3</sub>), 1.48–1.58 (m, 1H, CH<sub>2</sub>), 1.65 (d, *J*=1.6 Hz, 3H, CH<sub>3</sub>C=), 1.69 (d, *J*=1.6 Hz, 3H, CH<sub>3</sub>C=), 2.96 (qd, *J*=9.6, 3.2 Hz, 1H, CHCH<sub>2</sub>), 3.24 (d, *J*=9.6 Hz, 1H, H-2), 4.07–4.16 (m, 2H, CH<sub>2</sub>O), 4.18 (q, *J*=7.2 Hz, 2H, CH<sub>2</sub>O), 4.88 (m, 1H, =CH); <sup>13</sup>C NMR (CDCl<sub>3</sub>, 100.6 MHz, HETCOR) δ 11.4 (CH<sub>3</sub>), 13.9 (CH<sub>3</sub>), 14.0 (CH<sub>3</sub>), 18.2 (CH<sub>3</sub>), 25.8 (CH<sub>3</sub>), 26.4 (CH<sub>2</sub>), 39.9 (CH), 57.2 (CH), 60.8 (CH<sub>2</sub>), 61.0 (CH<sub>2</sub>), 124.2 (CH), 134.4 (C), 168.2 (C), 168.5 (C). HRMS calcd for C<sub>14</sub>H<sub>24</sub>O<sub>4</sub> 256.1675, found 256.1675. Anal. Calcd for C<sub>14</sub>H<sub>24</sub>O<sub>4</sub>: C, 65.50; H, 9.44. Found: C, 65.43; H, 9.66.

**3.1.16. Diethyl 2-(1-ethyl-2-propenyl)malonate (24c).** Operating as above, pure **24c** (67.9 g, 92%) was obtained from vinylmagnesium bromide (**22**, R<sub>2</sub>=R<sub>3</sub>=H; 0.5 M in THF, 390 mL, 0.39 mol), CuCl (0.65 g, 6.5 mmol), and diethyl 2-propylidenemalonate<sup>16</sup> (**23**, R<sub>1</sub>=Et; 65 g, 0.32 mol) after flash chromatography (hexane, 95:5 hexane/EtOAc): IR (film) 1732 cm<sup>−1</sup>; <sup>1</sup>H NMR (CDCl<sub>3</sub>, 400 MHz, COSY, HETCOR) δ 0.88 (t, *J*=7.6 Hz, 3H, CH<sub>3</sub>), 1.24 (t, *J*=7.2 Hz, 3H, CH<sub>3</sub>), 1.27 (t, *J*=7.2 Hz, 3H, CH<sub>3</sub>), 1.29 (m, 1H, CH<sub>2</sub>), 1.53 (m, 1H, CH<sub>2</sub>), 2.68 (qd, *J*=9.2, 3.6 Hz, 1H, CHCH<sub>2</sub>), 3.35 (d, *J*=9.2 Hz, 1H, H-2), 4.15 (q, *J*=7.2 Hz, 2H, CH<sub>2</sub>O), 4.19 (q, *J*=7.2 Hz, 2H, CH<sub>2</sub>O), 5.07–5.12 (m, 2H, =CH<sub>2</sub>), 5.59–5.68 (m, 1H, =CH<sub>2</sub>); <sup>13</sup>C NMR (CDCl<sub>3</sub>, 75.4 MHz, HETCOR) δ 11.4 (CH<sub>3</sub>), 14.0 (CH<sub>3</sub>), 25.2 (CH<sub>2</sub>), 45.6 (CH), 56.6 (CH), 61.0 (CH<sub>2</sub>), 61.1 (CH<sub>2</sub>), 117.3

(CH<sub>2</sub>), 137.7 (CH), 168.0 (C), 168.2 (C). HRMS calcd for C<sub>12</sub>H<sub>20</sub>O<sub>4</sub> (M<sup>+</sup>+H) *m/z* 228.1362, found 229.1439.

**3.1.17. 2-(1-Ethyl-2-methyl-2-propenyl)-1,3-propanediol (25a).** A solution of malonate **24a** (15.3 g, 0.06 mol) in Et<sub>2</sub>O (100 mL) was slowly added to a suspension of LiAlH<sub>4</sub> (6 g, 0.16 mol) in anhydrous Et<sub>2</sub>O (100 mL) at 0 °C. The mixture was stirred under Ar at 0 °C for 30 min, at room temperature for 30 min, and heated at reflux for 8 h. Then, the temperature was lowered to 0 °C, and EtOH was slowly added until the formation of a transparent solution. After 30 min the solvent was eliminated under reduced pressure. The residue was dissolved in 20% aqueous KOH, and the mixture was heated at reflux for 2 h. The solution was extracted with Et<sub>2</sub>O, and the combined ethereal extracts were dried, filtered, and concentrated to give diol **25a** (9.32 g, 93%): IR (film) 3100–3500 cm<sup>−1</sup>; <sup>1</sup>H NMR (CDCl<sub>3</sub>, 400 MHz, COSY, HETCOR) δ 0.80 (t, *J*=7.2 Hz, 3H, CH<sub>3</sub>), 1.21–1.30 (m, 1H, CH<sub>2</sub>), 1.55–1.70 (m, 2H, CH<sub>2</sub> and CH<sub>2</sub>C=), 1.60 (s, 3H, CH<sub>3</sub>), 1.95 (s, 2H, OH), 2.09 (ddd, *J*=10.8, 10.4, 3.6 Hz, 1H, H-2), 3.69 (dd, *J*=10.0, 6.0 Hz, 1H, CH<sub>2</sub>O), 3.77–3.82 (m, 2H, CH<sub>2</sub>O), 3.96 (dd, *J*=10.8, 3.2 Hz, 1H, CH<sub>2</sub>O), 4.76 (m, 1H, =CH<sub>2</sub>), 4.85 (m, 1H, =CH<sub>2</sub>); <sup>13</sup>C NMR (CDCl<sub>3</sub>, 100.6 MHz, HETCOR) δ 11.9 (CH<sub>3</sub>), 18.2 (CH<sub>3</sub>), 22.4 (CH<sub>2</sub>), 43.3 (CH), 46.8 (CH), 63.7 (CH<sub>2</sub>), 64.7 (CH<sub>2</sub>), 113.3 (CH<sub>2</sub>), 145.0 (C).

**3.1.18. 2-(1-Ethyl-3-methyl-2-butenyl)-1,3-propanediol (25b).** Operating as above, diol **25b** (20.4 g, 94%) was obtained from diester **24b** (32.3 g, 0.13 mol) after purification of the crude mixture by flash chromatography (Et<sub>2</sub>O): IR (film) 2800–3500 cm<sup>−1</sup>; <sup>1</sup>H NMR (CDCl<sub>3</sub>, 400 MHz, COSY, HETCOR) δ 0.81 (t, *J*=7.6 Hz, 3H, CH<sub>3</sub>), 1.13–1.24 (m, 1H, CH<sub>2</sub>), 1.49–1.59 (m, 1H, CH<sub>2</sub>), 1.61 (d, *J*=1.2 Hz, 3H, CH<sub>3</sub>C=), 1.65–1.71 (m, 1H, H-2), 1.72 (d, *J*=1.2 Hz, 3H, CH<sub>3</sub>C=), 2.22–2.29 (m, 1H, CHC=), 2.38 (br s, 1H, OH), 2.52 (br s, 1H, OH), 3.68–3.78 (m, 2H, CH<sub>2</sub>O), 3.82–3.87 (m, 2H, CH<sub>2</sub>O), 4.86 (m, 1H, =CH); <sup>13</sup>C NMR (CDCl<sub>3</sub>, 100.6 MHz, HETCOR) δ 11.7 (CH<sub>3</sub>), 18.2 (CH<sub>3</sub>), 25.7 (CH<sub>3</sub>), 25.9 (CH<sub>2</sub>), 38.3 (CH), 46.3 (CH), 64.8 (CH<sub>2</sub>), 65.4 (CH<sub>2</sub>), 126.7 (CH), 133.0 (C); mp 43–46 °C (hexane). HRMS calcd for C<sub>14</sub>H<sub>24</sub>O<sub>4</sub> (M<sup>+</sup>+H) *m/z* 172.1463, found 173.1541. Anal. Calcd for C<sub>10</sub>H<sub>20</sub>O<sub>2</sub>: C, 69.72; H, 11.70. Found: C, 69.67; H, 11.70.

**3.1.19. 2-(1-Ethyl-2-propenyl)-1,3-propanediol (25c).** Operating as above, diol **25c** (12.3 g, 97%) was obtained from malonate **24c** (32.3 g, 0.13 mol): IR (film) 3000–3600 cm<sup>−1</sup>; <sup>1</sup>H NMR (CDCl<sub>3</sub>, 400 MHz, COSY, HETCOR) δ 0.86 (t, *J*=7.2 Hz, 3H, CH<sub>3</sub>), 1.28 (m, 1H, CH<sub>2</sub>), 1.55 (m, 1H, CH<sub>2</sub>), 1.73 (m, 1H, H-2), 2.01 (m, 1H, CHC=), 2.70 (br s, 2H, OH), 3.71 (dd, *J*=10.4, 7.6 Hz, 1H, CH<sub>2</sub>O), 3.76 (dd, *J*=10.4, 7.6 Hz, 1H, CH<sub>2</sub>O), 3.85 (dd, *J*=10.4, 3.6 Hz, 2H, CH<sub>2</sub>O), 5.02 (dd, *J*=16.8, 2.0 Hz, 1H, =CH<sub>2</sub> *trans*), 5.06 (dd, *J*=10.0, 2.0 Hz, 1H, =CH<sub>2</sub> *cis*), 5.55 (ddd, *J*=16.8, 10.0, 10.0 Hz, 1H, =CH); <sup>13</sup>C NMR (CDCl<sub>3</sub>, 75.4 MHz, HETCOR) δ 11.8 (CH<sub>3</sub>), 24.7 (CH<sub>2</sub>), 44.8 (CH), 45.2 (CH), 63.7 (CH<sub>2</sub>), 64.3 (CH<sub>2</sub>), 116.0 (CH<sub>2</sub>), 139.8 (CH). Anal. Calcd for C<sub>8</sub>H<sub>16</sub>O<sub>2</sub>·1/4 EtOAc: C, 65.03; H, 10.91. Found: C, 65.09; H, 11.20.

**3.1.20. 2-(1-Ethyl-2-methyl-2-propenyl)propane-1,3-diol ditosylate (26a).** A solution of diol **25a** (8.70 g, 0.058 mol)

and tosyl chloride (66 g, 0.35 mol) in anhydrous THF (200 mL) was added to a suspension of KOH (30 g, 0.52 mol) in anhydrous THF (100 mL) at 0 °C. The crude mixture was stirred at 0 °C for 2 h and at room temperature for additional 3 days. The organic solvent was removed at reduced pressure, and the resulting residue was dissolved in CH<sub>2</sub>Cl<sub>2</sub> (400 mL). The organic solution was washed with ice-water, the aqueous layer was extracted with CH<sub>2</sub>Cl<sub>2</sub>, and the combined organic extracts were washed with brine, dried, and filtered. Removal of the solvent followed by flash chromatography (gradient hexane/EtOAc) afforded ditosylate **26a** (17.3 g, 64%): IR (film) 1178, 1364 cm<sup>-1</sup>; <sup>1</sup>H NMR (CDCl<sub>3</sub>, 400 MHz, COSY, HETCOR) δ 0.67 (t, *J* = 7.2 Hz, 3H, CH<sub>3</sub>), 1.10 (m, 1H, CH<sub>2</sub>), 1.32 (m, 1H, CH<sub>2</sub>), 1.46 (d, *J* = 0.4 Hz, 3H, CH<sub>3</sub>), 1.90 (m, 1H, CHC=), 1.95 (qd, *J* = 10.4, 3.6 Hz, 1H, H-2), 2.45 (s, 3H, CH<sub>3</sub>Ar), 2.46 (s, 3H, CH<sub>3</sub>Ar), 3.79 (dd, *J* = 10.4, 7.6 Hz, 1H, CH<sub>2</sub>O), 4.00 (dd, *J* = 10.4, 5.6 Hz, 1H, CH<sub>2</sub>O), 4.02 (dd, *J* = 10.4, 6.8 Hz, 1H, CH<sub>2</sub>O), 4.15 (dd, *J* = 10.4, 3.2 Hz, 1H, CH<sub>2</sub>O), 4.61 (m, 1H, =CH<sub>2</sub>), 4.77 (m, 1H, =CH<sub>2</sub>), 7.33 (d, *J* = 8.0 Hz, 2H, ArH), 7.35 (d, *J* = 8.0 Hz, 2H, ArH), 7.71 (d, *J* = 8.0 Hz, 2H, ArH), 7.75 (d, *J* = 8.0 Hz, 2H, ArH); <sup>13</sup>C NMR (CDCl<sub>3</sub>, 100.6 MHz, HETCOR) δ 11.4 (CH<sub>3</sub>), 17.6 (CH<sub>3</sub>), 21.6 (CH<sub>3</sub>), 21.7 (CH<sub>2</sub>), 39.7 (CH), 45.7 (CH), 66.7 (CH<sub>2</sub>), 67.9 (CH<sub>2</sub>), 115.0 (CH<sub>2</sub>), 127.6 (CH), 127.7 (CH), 129.7 (CH), 129.8 (CH), 132.2 (C), 132.4 (C), 142.5 (CH), 144.8 (C), 144.9 (C). Anal. Calcd for C<sub>23</sub>H<sub>30</sub>O<sub>6</sub>S<sub>2</sub>: C, 59.20; H, 6.48; S, 13.74. Found: C, 59.39; H, 6.56; S, 13.88.

**3.1.21. 2-(1-Ethyl-3-methyl-2-butenyl)-1,3-propanediol ditosylate (26b).** Operating as above (reaction conditions: 18 h at 0 °C), ditosylate **26b** (43.9 g, 88%) was obtained from diol **25b** (18.0 g, 0.10 mol) after flash chromatography (8:1 hexane/EtOAc): IR (film) 1177, 1362 cm<sup>-1</sup>; <sup>1</sup>H NMR (CDCl<sub>3</sub>, 400 MHz, COSY, HETCOR) δ 0.70 (t, *J* = 7.2 Hz, 3H, CH<sub>3</sub>), 0.96–1.08 (m, 1H, CH<sub>2</sub>), 1.29–1.38 (m, 1H, CH<sub>2</sub>), 1.49 (d, *J* = 0.8 Hz, 3H, CH<sub>3</sub>C=), 1.63 (d, *J* = 1.2 Hz, 3H, CH<sub>3</sub>C=), 1.83 (m, 1H, H-2), 2.18–2.26 (m, 1H, CHC=), 2.46 (s, 6H, CH<sub>3</sub>Ar), 3.85 (dd, *J* = 10.0, 7.6 Hz, 1H, CH<sub>2</sub>O), 3.96–4.06 (m, 3H, CH<sub>2</sub>O), 4.62 (m, 1H, =CH), 7.34 (d, *J* = 8.0 Hz, 2H, ArH), 7.35 (d, *J* = 8.0 Hz, 2H, ArH), 7.71 (d, *J* = 8.4 Hz, 2H, ArH), 7.74 (d, *J* = 8.4 Hz, 2H, ArH); <sup>13</sup>C NMR (CDCl<sub>3</sub>, 100.6 MHz, HETCOR) δ 11.3 (CH<sub>3</sub>), 18.3 (CH<sub>3</sub>), 21.6 (CH<sub>3</sub>), 25.2 (CH<sub>2</sub>), 25.8 (CH<sub>3</sub>), 37.1 (CH), 42.2 (CH), 67.6 (CH<sub>2</sub>), 67.8 (CH<sub>2</sub>), 124.5 (CH), 127.8 (CH), 127.9 (CH), 129.8 (CH), 129.9 (CH), 132.5 (C), 132.6 (C), 135.2 (C), 144.8 (C), 144.9 (C). HRMS calcd for C<sub>24</sub>H<sub>32</sub>O<sub>6</sub>S<sub>2</sub> (M<sup>+</sup> + H) *m/z* 480.1640, found 481.1719. Anal. Calcd for C<sub>24</sub>H<sub>32</sub>O<sub>6</sub>S<sub>2</sub>: C, 59.97; H, 6.71; S, 13.34. Found: C, 60.04; H, 6.96; S, 13.24.

**3.1.22. 2-(1-Ethyl-2-propenyl)-1,3-propanediol ditosylate (26c).** Operating as above, ditosylate **26c** (81.1 g, 88%) was obtained from diol **25c** (15 g, 0.10 mol) after flash chromatography (4:1 hexane/EtOAc): IR (NaCl) 1167, 1360 cm<sup>-1</sup>; <sup>1</sup>H NMR (CDCl<sub>3</sub>, 400 MHz, COSY, HETCOR) δ 0.75 (t, *J* = 7.6 Hz, 3H, CH<sub>3</sub>), 1.14 (m, 1H, CH<sub>2</sub>), 1.34 (m, 1H, CH<sub>2</sub>), 1.96 (m, 2H, CHC= and H-2), 2.46 (s, 6H, CH<sub>3</sub>Ar), 3.85 (dd, *J* = 10.0, 7.6 Hz, 1H, CH<sub>2</sub>O), 3.98 (dd, *J* = 10.0, 5.2 Hz, 1H, CH<sub>2</sub>O), 4.04 (dd, *J* = 10.0, 4.8 Hz, 1H, CH<sub>2</sub>O), 4.08 (dd, *J* = 10.0, 4.0 Hz, 1H, CH<sub>2</sub>O), 4.88 (dd, *J* = 16.8, 1.6 Hz, 1H, =CH<sub>2</sub> *trans*), 5.00 (dd, *J* = 10.0, 1.6 Hz, 1H, =CH<sub>2</sub> *cis*), 5.32 (ddd, *J* = 16.8, 10.0,

10.0 Hz, 1H, =CH), 7.35 (m, 4H, ArH), 7.74 (m, 4H, ArH); <sup>13</sup>C NMR (CDCl<sub>3</sub>, 75.4 MHz, HETCOR) δ 11.4 (CH<sub>3</sub>), 21.6 (CH<sub>3</sub>), 24.1 (CH<sub>2</sub>), 41.1 (CH), 43.5 (CH), 67.3 (CH<sub>2</sub>), 67.5 (CH<sub>2</sub>), 118.0 (CH<sub>2</sub>), 127.7 (CH), 127.8 (CH), 129.7 (CH), 129.8 (CH), 132.3 (C), 132.4 (C), 137.5 (CH), 144.8 (C), 144.9 (C). Anal. Calcd for C<sub>22</sub>H<sub>28</sub>O<sub>6</sub>S<sub>2</sub>: C, 58.39; H, 6.24; S, 14.17. Found: C, 58.58; H, 6.30; S, 13.90.

**3.1.23. 3-(1-Ethyl-2-methyl-2-propenyl)pentanedinitrile (27a).** Compound **26a** (3.8 g, 8.15 mmol) and NaCN (1.6 g, 33 mmol) were dissolved in anhydrous DMSO (30 mL), and the mixture was stirred under Ar at room temperature for 10 min and at 75 °C for 20 h. The crude mixture was diluted with EtOAc (100 mL) and ice-H<sub>2</sub>O (100 mL). The aqueous layer was extracted with EtOAc. The combined organic extracts were washed with brine, dried, and concentrated to give an oil, which was chromatographed (6:1 hexane/EtOAc) to give pure **27a** (1.24 g, 86%): IR (film) 2243 cm<sup>-1</sup>; <sup>1</sup>H NMR (CDCl<sub>3</sub>, 400 MHz, COSY, HETCOR) δ 0.87 (t, *J* = 7.2 Hz, 3H, CH<sub>3</sub>), 1.28 (m, 1H, CH<sub>2</sub>), 1.57 (m, 1H, CH<sub>2</sub>), 1.61 (s, 3H, CH<sub>3</sub>), 2.05 (m, 2H, H-3 and CHC=), 2.40 (dd, *J* = 17.2, 7.6 Hz, 1H, CH<sub>2</sub>CN), 2.58 (dd, *J* = 17.2, 6.4 Hz, 1H, CH<sub>2</sub>CN), 2.64 (dd, *J* = 17.2, 2.6 Hz, 1H, CH<sub>2</sub>CN), 2.76 (dd, *J* = 17.2, 3.6 Hz, 1H, CH<sub>2</sub>CN), 4.89 (m, 1H, =CH<sub>2</sub>), 5.00 (m, 1H, =CH<sub>2</sub>); <sup>13</sup>C NMR (CDCl<sub>3</sub>, 100.6 MHz, HETCOR) δ 11.6 (CH<sub>3</sub>), 17.8 (CH<sub>3</sub>), 19.5 (CH<sub>2</sub>), 20.7 (CH<sub>2</sub>), 22.2 (CH<sub>2</sub>), 34.8 (CH), 51.1 (CH), 116.4 (CH<sub>2</sub>), 117.0 (C), 117.4 (C), 142.2 (C). Anal. Calcd for C<sub>11</sub>H<sub>16</sub>N<sub>2</sub>: C, 74.96; H, 9.15; N, 15.89. Found: C, 75.01; H, 9.15; N, 15.71.

**3.1.24. 3-(1-Ethyl-3-methyl-2-butenyl)pentanedinitrile (27b).** Operating as above, dinitrile **27b** (15.5 g, 90%) was obtained from ditosylate **26b** (43.5 g, 0.09 mol) after flash chromatography (3:7 hexane/EtOAc): IR (film) 2247 cm<sup>-1</sup>; <sup>1</sup>H NMR (CDCl<sub>3</sub>, 400 MHz, COSY, HETCOR) δ 0.86 (t, *J* = 7.2 Hz, 3H, CH<sub>3</sub>), 1.20 (m, 1H, CH<sub>2</sub>), 1.54 (m, 1H, CH<sub>2</sub>), 1.68 (d, *J* = 1.2 Hz, 3H, CH<sub>3</sub>C=), 1.77 (d, *J* = 1.2 Hz, 3H, CH<sub>3</sub>C=), 2.02 (m, 1H, H-3), 2.34–2.42 (m, 2H, CH<sub>2</sub>CN and CHC=), 2.52–2.65 (m, 3H, CH<sub>2</sub>CN), 4.75 (dm, *J* = 10.4 Hz, 1H, =CH); <sup>13</sup>C NMR (CDCl<sub>3</sub>, 100.6 MHz, HETCOR) δ 11.4 (CH<sub>3</sub>), 18.5 (CH<sub>3</sub>), 19.4 (CH<sub>2</sub>), 19.9 (CH<sub>2</sub>), 25.5 (CH<sub>2</sub>), 25.9 (CH<sub>3</sub>), 37.4 (CH), 41.6 (CH), 117.4 (C), 117.8 (C), 123.3 (CH), 137.0 (C). HRMS calcd for C<sub>12</sub>H<sub>20</sub>N<sub>2</sub> (M<sup>+</sup> + H) *m/z* 190.1470, found 191.1548. Anal. Calcd for C<sub>12</sub>H<sub>18</sub>N<sub>2</sub>: C, 75.74; H, 9.53; N, 14.72. Found: C, 75.94; H, 9.60; N, 14.76.

**3.1.25. 3-(1-Ethyl-2-propenyl)pentanedinitrile (27c).** Operating as above (reaction time 8 h), compound **27c** (24.6 g, 88%) was obtained from **26c** (78 g, 0.17 mol) after flash chromatography (4:1 hexane/EtOAc): IR (film) 2247 cm<sup>-1</sup>; <sup>1</sup>H NMR (CDCl<sub>3</sub>, 400 MHz, COSY, HETCOR) δ 0.91 (t, *J* = 7.2 Hz, 3H, CH<sub>3</sub>), 1.32 (m, 1H, CH<sub>2</sub>), 1.54 (m, 1H, CH<sub>2</sub>), 2.11 (m, 2H, H-3 and CHC=), 2.39 (dd, *J* = 17.2, 8.0 Hz, 1H, CH<sub>2</sub>CN), 2.58 (dd, *J* = 17.2, 6.4 Hz, 1H, CH<sub>2</sub>CN), 2.61 (dd, *J* = 10.0, 6.0 Hz, 1H, CH<sub>2</sub>CN), 2.65 (dd, *J* = 10.0, 4.0 Hz, 1H, CH<sub>2</sub>CN), 5.21 (ddd, *J* = 16.8, 10.0, 0.4 Hz, 1H, =CH<sub>2</sub> *trans*), 5.27 (dd, *J* = 10.0, 1.6 Hz, 1H, =CH<sub>2</sub> *cis*), 5.45 (ddd, *J* = 16.8, 10.0, 10.0 Hz, 1H, =CH); <sup>13</sup>C NMR (CDCl<sub>3</sub>, 75.4 MHz, HETCOR) δ 11.3 (CH<sub>3</sub>), 19.2 (CH<sub>2</sub>), 19.7 (CH<sub>2</sub>), 24.2 (CH<sub>2</sub>), 35.8 (CH), 47.7 (CH), 117.1 (C), 117.3 (C), 119.4

(CH<sub>2</sub>), 136.2 (CH). Anal. Calcd for C<sub>10</sub>H<sub>14</sub>N<sub>2</sub>: C, 74.03; H, 8.70; N, 17.27. Found: C, 73.63; H, 8.67; N, 17.14.

**3.1.26. 3-(1-Ethyl-2-methyl-2-propenyl)pentanedioic acid (28a).** A mixture of dinitrile **27a** (1.05 g, 6 mmol) and 35% aqueous NaOH solution (15 g) in MeOH (20 mL) was heated at reflux for 4 h. The MeOH was eliminated under reduced pressure, and the aqueous solution was heated at reflux temperature for additional 2 h. The crude mixture was cooled at 0 °C and brought to pH 1 by careful addition of 6 N aqueous HCl. The aqueous layer was extracted with EtOAc, and the combined organic extracts were washed with brine, dried, and concentrated. Flash chromatography (Et<sub>2</sub>O) gave diacid **28a** (1.1 g, 86%): IR (film) 1724, 2500–3500 cm<sup>-1</sup>; <sup>1</sup>H NMR (CDCl<sub>3</sub>, 400 MHz, COSY, HETCOR) δ 0.83 (t, *J* = 7.2 Hz, 3H, CH<sub>3</sub>), 1.31 (m, 1H, CH<sub>2</sub>), 1.53 (m, 1H, CH<sub>2</sub>), 1.65 (s, 3H, CH<sub>3</sub>), 1.83 (m, 1H, CHC=), 2.16 (m, 2H, CH<sub>2</sub>CO), 2.46 (m, 1H, H-3), 2.57 (dd, *J* = 16.0, 2.0 Hz, 1H, CH<sub>2</sub>CO), 2.63 (dd, *J* = 14.4, 2.8 Hz, 1H, CH<sub>2</sub>CO), 4.72 (m, 1H, =CH<sub>2</sub>), 4.92 (m, 1H, =CH<sub>2</sub>); <sup>13</sup>C NMR (CDCl<sub>3</sub>, 100.6 MHz, HETCOR) δ 12.4 (CH<sub>3</sub>), 19.4 (CH<sub>3</sub>), 22.4 (CH<sub>2</sub>), 35.0 (CH), 38.1 (CH<sub>2</sub>), 38.7 (CH<sub>2</sub>), 53.4 (CH), 114.8 (CH<sub>2</sub>), 144.6 (C), 180.6 (C). Anal. Calcd for C<sub>11</sub>H<sub>18</sub>O<sub>4</sub>: C, 61.66; H, 8.47. Found: C, 61.25; H, 8.58.

**3.1.27. 3-(1-Ethyl-3-methyl-2-butenyl)pentanedioic acid (28b).** Operating as above, pure diacid **28b** (16.7 g, 82%) was obtained from compound **27b** (17.0 g, 0.09 mol) after flash chromatography (Et<sub>2</sub>O): IR (film) 1697, 2800–3500 cm<sup>-1</sup>; <sup>1</sup>H NMR (CDCl<sub>3</sub>, 400 MHz, COSY, HETCOR) δ 0.83 (t, *J* = 7.2 Hz, 3H, CH<sub>3</sub>), 1.20 (m, 1H, CH<sub>2</sub>), 1.43–1.51 (m, 1H, CH<sub>2</sub>), 1.60 (s, 3H, CH<sub>3</sub>C=), 1.72 (s, 3H, CH<sub>3</sub>C=), 2.18–2.31 (m, 3H, CH<sub>2</sub>CO, CHC= and H-3), 2.40–2.53 (m, 3H, CH<sub>2</sub>CO), 4.79 (d, *J* = 10.4 Hz, 1H, =CH), 6.10 (s.a., 2H, OH); <sup>13</sup>C NMR (CDCl<sub>3</sub>, 100.6 MHz, HETCOR) δ 11.8 (CH<sub>3</sub>), 18.3 (CH<sub>3</sub>), 25.7 (CH<sub>2</sub>), 25.9 (CH<sub>3</sub>), 35.6 (CH<sub>2</sub>), 36.5 (CH), 37.8 (CH<sub>2</sub>), 43.2 (CH), 125.1 (CH), 134.5 (C), 178.9 (C); mp 99–101 °C. HRMS calcd for C<sub>12</sub>H<sub>20</sub>O<sub>4</sub> 228.1362, found 228.1362. Anal. Calcd for C<sub>10</sub>H<sub>20</sub>O<sub>4</sub>: C, 63.14; H, 8.83. Found: C, 63.34; H, 8.98.

**3.1.28. 3-(1-Ethyl-2-propenyl)pentanedioic acid (28c).** Operating as above, diacid **28c** (25.8 g, 95%) was obtained from **27c** (22 g, 0.14 mol): IR (film) 1721, 2500–3500 cm<sup>-1</sup>; <sup>1</sup>H NMR (CDCl<sub>3</sub>, 400 MHz, COSY, HETCOR) δ 0.89 (t, *J* = 7.2 Hz, 3H, CH<sub>3</sub>), 1.34 (m, 1H, CH<sub>2</sub>), 1.48 (m, 1H, CH<sub>2</sub>), 1.91 (m, 1H, CH), 2.16 (dd, *J* = 15.2, 12.0 Hz, 1H, CH<sub>2</sub>CO), 2.25 (dd, *J* = 14.0, 11.2 Hz, 1H, CH<sub>2</sub>CO), 2.44 (ddd, *J* = 14.0, 2.0, 0.8 Hz, 1H, CH<sub>2</sub>CO), 2.56 (m, 2H, H-3, CH<sub>2</sub>CO), 5.04 (ddd, *J* = 16.8, 2.0, 0.8 Hz, 1H, =CH<sub>2</sub> *trans*), 5.14 (dd, *J* = 10.4, 2.0 Hz, 1H, =CH<sub>2</sub> *cis*), 5.50 (ddd, *J* = 16.8, 10.4, 9.2 Hz, 1H, =CH); <sup>13</sup>C NMR (CDCl<sub>3</sub>, 100.6 MHz, HETCOR) δ 11.9 (CH<sub>3</sub>), 24.6 (CH<sub>2</sub>), 35.9 (CH), 36.1 (CH<sub>2</sub>), 38.7 (CH<sub>2</sub>), 50.4 (CH), 117.8 (CH<sub>2</sub>), 138.1 (CH), 180.1 (C), 180.2 (C); mp 78–79 °C (hexane). Anal. Calcd for C<sub>10</sub>H<sub>16</sub>O<sub>4</sub>: C, 59.98; H, 8.05. Found: C, 60.15; H, 8.05.

**3.1.29. Dimethyl 3-(1-ethyl-2-methyl-2-propenyl)pentanedioate (29a).** Me<sub>3</sub>SiCl (50 mL, 393 mol) was added to a solution of diacid **28a** (19.1 g, 89 mmol) in anhydrous MeOH (300 mL), and the mixture was stirred at

room temperature for 24 h. The solvent was eliminated under reduced pressure, and the residue was dissolved in Et<sub>2</sub>O and washed with 5% aqueous NaHCO<sub>3</sub>. The aqueous layer was extracted with Et<sub>2</sub>O, and the combined organic extracts were washed with brine, dried, and evaporated to give pure **29a** (19.6 g, 91%): IR (film) 1739 cm<sup>-1</sup>; <sup>1</sup>H NMR (CDCl<sub>3</sub>, 400 MHz, COSY, HETCOR) δ 0.80 (t, *J* = 7.2 Hz, 3H, CH<sub>3</sub>), 1.19–1.31 (m, 1H, CH<sub>2</sub>), 1.45–1.54 (m, 1H, CH<sub>2</sub>), 1.62 (s, 3H, CH<sub>3</sub>), 1.94–2.00 (m, 1H, CHC=), 2.28–2.52 (m, 5H, H-2, H-4 and H-3), 3.65 (s, 3H, OCH<sub>3</sub>), 3.66 (s, 3H, OCH<sub>3</sub>), 4.70 (m, 1H, =CH<sub>2</sub>), 4.87 (m, 1H, =CH<sub>2</sub>); <sup>13</sup>C NMR (CDCl<sub>3</sub>, 100.6 MHz, HETCOR) δ 12.1 (CH<sub>3</sub>), 19.0 (CH<sub>3</sub>), 22.0 (CH<sub>2</sub>), 34.1 (CH), 35.8 (CH<sub>2</sub>), 36.7 (CH<sub>2</sub>), 51.3 (CH<sub>3</sub>), 51.4 (CH<sub>3</sub>), 51.7 (CH), 113.9 (CH<sub>2</sub>), 144.6 (C), 173.1 (C). Anal. Calcd for C<sub>13</sub>H<sub>22</sub>O<sub>4</sub>: C, 64.44; H, 9.15. Found: C, 64.40; H, 9.10.

**3.1.30. Dimethyl 3-(1-ethyl-3-methyl-2-butenyl)pentanedioate (29b).** Operating as above, pure compound **29b** (16.4, 92%) was obtained from diacid **28b** (15.9 g, 0.07 mol) after flash chromatography (Et<sub>2</sub>O): IR (film) 1739 cm<sup>-1</sup>; <sup>1</sup>H NMR (CDCl<sub>3</sub>, 400 MHz, COSY, HETCOR) δ 0.81 (t, *J* = 7.2 Hz, 3H, CH<sub>3</sub>), 1.10–1.22 (m, 1H, CH<sub>2</sub>), 1.42–1.53 (m, 1H, CH<sub>2</sub>), 1.57 (d, *J* = 1.6 Hz, 3H, CH<sub>3</sub>C=), 1.71 (d, *J* = 1.2 Hz, 3H, CH<sub>3</sub>C=), 2.18–2.46 (m, 6H, H-2, H-3, H-4, and CHC=), 3.65 (s, 6H, OCH<sub>3</sub>), 4.78 (dm, *J* = 10.4 Hz, 1H, =CH); <sup>13</sup>C NMR (CDCl<sub>3</sub>, 100.6 MHz, HETCOR) δ 11.9 (CH<sub>3</sub>), 18.2 (CH<sub>3</sub>), 25.6 (CH<sub>2</sub>), 25.9 (CH<sub>3</sub>), 35.3 (CH<sub>2</sub>), 36.4 (CH), 36.7 (CH<sub>2</sub>), 42.3 (CH), 51.3 (CH<sub>3</sub>), 51.4 (CH<sub>3</sub>), 125.4 (CH), 134.3 (C), 173.3 (C), 173.6 (C). HRMS calcd for C<sub>14</sub>H<sub>24</sub>O<sub>4</sub> 256.1675, found 256.1675. Anal. Calcd for C<sub>14</sub>H<sub>24</sub>O<sub>4</sub> · 1/4 EtOAc: C, 64.72; H, 9.41. Found: C, 65.01; H, 9.71.

**3.1.31. Dimethyl 3-(1-ethyl-2-propenyl)pentanedioate (29c).** Operating as above, pure **29c** (27.1 g, 92%) was obtained from diacid **28c** (25.8 g, 0.13 mol) after flash chromatography (Et<sub>2</sub>O): IR (film) 1739 cm<sup>-1</sup>; <sup>1</sup>H NMR (CDCl<sub>3</sub>, 400 MHz, COSY, HETCOR) δ 0.87 (t, *J* = 7.2 Hz, 3H, CH<sub>3</sub>), 1.27 (m, 1H, CH<sub>2</sub>), 1.47 (m, 1H, CH<sub>2</sub>), 1.98 (m, 1H, CHC=), 2.19 (dd, *J* = 16.8, 10.0 Hz, 1H, H-2), 2.37 (m, 2H, H-2), 2.44 (m, 2H, H-2 and H-3), 3.65 (s, 3H, OCH<sub>3</sub>), 3.66 (s, 3H, OCH<sub>3</sub>), 5.01 (ddd, *J* = 17.2, 2.0, 0.8 Hz, 1H, =CH<sub>2</sub> *trans*), 5.11 (dd, *J* = 10.4, 2.0 Hz, 1H, =CH<sub>2</sub> *cis*), 5.47 (ddd, *J* = 16.8, 10.4, 9.2 Hz, 1H, =CH); <sup>13</sup>C NMR (CDCl<sub>3</sub>, 75.4 MHz, HETCOR) δ 11.9 (CH<sub>3</sub>), 24.4 (CH<sub>2</sub>), 35.0 (CH<sub>2</sub>), 35.4 (CH), 36.7 (CH<sub>2</sub>), 48.6 (CH), 51.2 (CH<sub>3</sub>), 51.3 (CH<sub>3</sub>), 117.3 (CH<sub>2</sub>), 138.3 (CH), 172.8 (C), 173.0 (C). Anal. Calcd for C<sub>12</sub>H<sub>20</sub>O<sub>4</sub>: C, 63.14; H, 8.83. Found: C, 63.00; H, 8.79.

**3.1.32. Dimethyl and diethyl 3-(2-oxoethyl)glutarate (1).** *Method A.* Operating as described for the preparation of compound **5b** (reaction time 16 h), methyl ester **1a** (70.3 mg, 57%) was obtained from triester **8** (211 mg, 0.60 mmol) after flash chromatography (hexane): IR (film) 1735 cm<sup>-1</sup>; <sup>1</sup>H NMR (CDCl<sub>3</sub>, 300 MHz) δ 2.46 (dd, *J* = 6.6, 4.2 Hz, 4H, H-2 and H-4), 2.64 (dd, *J* = 6.3, 1.5 Hz, 2H, CH<sub>2</sub>CHO), 2.88 (td, *J* = 13.2, 6.3 Hz, 1H, H-3), 3.67 (s, 6H, OCH<sub>3</sub>), 9.79 (s, 1H, CHO); <sup>13</sup>C NMR (CDCl<sub>3</sub>, 75.4 MHz) δ 26.5 (CH), 37.6 (CH<sub>2</sub>), 47.3 (CH<sub>2</sub>), 51.6 (CH<sub>3</sub>), 172.1 (C), 200.4 (C). HRMS calcd for C<sub>9</sub>H<sub>14</sub>O<sub>5</sub> 202.1723, found 202.1719.

**Method B.** A solution of  $\text{LiBF}_4$  (132 mg, 1.3 mmol) in acetonitrile (15 mL) containing 2% of  $\text{H}_2\text{O}$  was added via cannula to a solution of acetal **12** (326 mg, 1.31 mmol) in acetonitrile (2.5 mL), and the resulting solution was stirred at room temperature for 3 h. The crude mixture was poured into brine, and the aqueous layer was extracted with EtOAc. The combined organic extracts were dried, filtered, and concentrated. The resulting oil was chromatographed (hexane) affording compound **1a** (161 mg, 61%).

**Method C.** A mixture of nitrile **15** (222 mg, 0.98 mmol),  $\text{NaH}_2\text{PO}_2$  (650 mg), and Raney Ni (108 mg) in pyridine-AcOH- $\text{H}_2\text{O}$  (2:1:1, 8 mL) was stirred at 50 °C for 5 h. The catalyst was removed by filtration, and the solvent was evaporated. The residue was dissolved in EtOAc, and the organic layer was washed with  $\text{H}_2\text{O}$ , dried, filtered, and concentrated to give a yellow oil (169 mg), which was chromatographed (1:1 hexane/EtOAc) affording ethyl glutarate **1b** (143 mg, 64%) as a transparent oil: IR (film) 1736  $\text{cm}^{-1}$ ;  $^1\text{H}$  NMR ( $\text{CDCl}_3$ , 300 MHz)  $\delta$  1.25 (t,  $J=7.2$  Hz, 6H,  $\text{CH}_3$ ), 2.45 (dd,  $J=6.6, 4.2$  Hz, 4H, H-2 and H-4), 2.63 (dd,  $J=6.6, 1.2$  Hz, 2H,  $\text{CH}_2\text{CHO}$ ), 2.88 (q,  $J=6.6$  Hz, 1H, H-3), 4.11 (q,  $J=7.2$  Hz, 4H,  $\text{CH}_2$ ), 9.75 (s, 1H, CHO);  $^{13}\text{C}$  NMR ( $\text{CDCl}_3$ , 75.4 MHz)  $\delta$  14.2 ( $\text{CH}_3$ ), 26.5 (CH), 37.9 ( $\text{CH}_2$ ), 47.3 ( $\text{CH}_2$ ), 60.4 ( $\text{CH}_2$ ), 171.6 (C), 200.5 (C).

**Method D.** Malonate (**24d**) was converted to dimethyl 3-allylpentadioate (**29d**) via the intermediates **25d–28d** in the yields indicated in Table 1, following reported procedures.<sup>15</sup> A stream of ozone gas was bubbled through a cooled (−78 °C) solution of diester **29d** (2.5 g, 12.5 mmol) in  $\text{CH}_2\text{Cl}_2$  (40 mL) until it turned pale blue. The solution was purged with Ar until disappearance of the blue color. Then  $\text{SMe}_2$  (35 mL, 475 mmol) was added, and the temperature was raised to 25 °C. After 30 h of stirring, the crude mixture was evaporated under reduced pressure. The residue was dissolved in  $\text{CH}_2\text{Cl}_2$  and washed with  $\text{H}_2\text{O}$ . The aqueous layer was extracted with  $\text{CH}_2\text{Cl}_2$ , and the combined organic extracts were washed with brine, dried, and filtered to give, after column chromatography (3:1 hexane/EtOAc), pure methyl ester **1a** (2.10 g, 84%).

**3.1.33. Dimethyl and diethyl 3-(1-formylpropyl)glutarate (2).** **Method A.** Nitrile **15** (100 mg, 0.39 mmol) was reduced operating as described in the above Method C, with addition of  $\text{NaH}_2\text{PO}_2$  (273 mg) and Raney Ni (65 mg) at intervals of 6 h during 24 h. After flash chromatography (1:1 hexane/EtOAc) a 4:1 mixture of **2b** and **15** (71 mg, 57%) was obtained;  $^1\text{H}$  NMR ( $\text{CDCl}_3$ , 300 MHz)  $\delta$  0.95 (t,  $J=7.4$  Hz, 3H,  $\text{CH}_3$ ), 1.25 (t,  $J=7.6$  Hz, 6H,  $\text{CH}_3$ ), 1.69 (dd,  $J=7.6, 2.2$  Hz, 2H,  $\text{CH}_2$ ), 2.37–2.55 (m, 4H, H-2 and H-4), 2.61 (m, 1H, H-3), 2.83 (m, 1H,  $\text{CHCHO}$ ), 4.07–4.21 (m, 4H,  $\text{CH}_2$ ), 9.66 (d,  $J=2.2$  Hz, 1H, CHO);  $^{13}\text{C}$  NMR ( $\text{CDCl}_3$ , 75.4 MHz)  $\delta$  12.1 ( $\text{CH}_3$ ), 14.1 ( $\text{CH}_3$ ), 22.2 ( $\text{CH}_2$ ), 33.2 (CH), 33.6 ( $\text{CH}_2$ ), 33.7 ( $\text{CH}_2$ ), 49.2 (CH), 60.4 ( $\text{CH}_2$ ), 60.5 ( $\text{CH}_2$ ), 172.0 (C), 172.2 (C), 203.7 (C).

**Method B.** Diester **29b** (262 mg, 1.02 mmol) was ozonolyzed as described in the above Method D. After stirring in the presence of  $\text{SMe}_2$  for 4 h and flash chromatography (1:1 hexane/EtOAc), ketodiester **2a** (150 mg, 64%) was obtained: IR (film) 1735  $\text{cm}^{-1}$ ;  $^1\text{H}$  NMR ( $\text{CDCl}_3$ ,

300 MHz, COSY, HETCOR)  $\delta$  0.96 (t,  $J=7.2$  Hz, 3H,  $\text{CH}_3$ ), 1.67–1.82 (m, 1H,  $\text{CH}_2$ ), 1.42–1.56 (m, 1H,  $\text{CH}_2$ ), 2.40–2.48 (m, 5H, H-2, H-4 and  $\text{CHCHO}$ ), 2.80 (m, 1H, H-3), 3.67 (s, 3H,  $\text{OCH}_3$ ), 3.68 (s, 3H,  $\text{OCH}_3$ ), 9.66 (d,  $J=2,4$  Hz, 1H, CHO);  $^{13}\text{C}$  NMR ( $\text{CDCl}_3$ , 75.4 MHz, HETCOR)  $\delta$  12.0 ( $\text{CH}_3$ ), 18.6 ( $\text{CH}_2$ ), 31.3 (CH), 35.4 ( $\text{CH}_2$ ), 35.7 ( $\text{CH}_2$ ), 51.6 ( $\text{CH}_3$ ), 51.7 ( $\text{CH}_3$ ), 55.4 (CH), 172.2 (C), 172.3 (C), 203.5 (C).

**Method C.** Operating as described in the above Method D, diester **2a** (1.09 g, 75%) was obtained from **29c** (1.5 g, 6.6 mol) after flash chromatography (1:1 hexane/EtOAc).

**3.1.34. Dimethyl 3-(1-ethyl-2-oxopropyl)pentadionate (4a).** Diester **29a** (2.5 g, 10 mmol) was ozonolyzed as described in the above Method D. After stirring in the presence of  $\text{SMe}_2$  for 20 h and flash chromatography (gradient hexane–EtOAc), ketodiester **4a** (1.76 g, 65%) was obtained: IR (film) 1710, 1735  $\text{cm}^{-1}$ ;  $^1\text{H}$  NMR ( $\text{CDCl}_3$ , 400 MHz, COSY, HETCOR)  $\delta$  0.85 (t,  $J=7.2$  Hz, 3H,  $\text{CH}_3$ ), 1.35–1.45 (m, 1H,  $\text{CH}_2$ ), 1.60–1.71 (m, 1H,  $\text{CH}_2$ ), 2.21 (s, 3H,  $\text{CH}_3$ ), 2.28 (dd,  $J=16.0, 8.0$  Hz, 1H, H-2 or H-4), 2.37–2.49 (m, 3H, H-2 and H-4), 2.62–2.71 (m, 2H, H-3 and  $\text{CHCO}$ ), 3.66 (s, 3H,  $\text{OCH}_3$ ), 3.69 (s, 3H,  $\text{OCH}_3$ );  $^{13}\text{C}$  NMR ( $\text{CDCl}_3$ , 50 MHz, HETCOR)  $\delta$  12.0 ( $\text{CH}_3$ ), 20.0 ( $\text{CH}_2$ ), 30.6 ( $\text{CH}_3$ ), 32.3 (CH), 34.7 ( $\text{CH}_2$ ) 36.1 ( $\text{CH}_2$ ), 51.5 ( $\text{CH}_3$ ), 55.5 (CH), 172.3 (C), 172.4 (C), 210.9 (C). Anal. Calcd for  $\text{C}_{12}\text{H}_{20}\text{O}_5$ : C, 59.00; H, 8.25. Found: C, 58.73; H, 8.23.

## Acknowledgements

This work was supported by the Ministry of Science and Technology (Spain)-FEDER through project BQU2003-00505. Thanks are also due to the DURSI, Generalitat de Catalunya, for Grant 2001SGR-0084 and the Ministry of Education, Culture and Sport (Spain) for a fellowship to O.B., and the Fundação para a Ciência e Tecnologia (Portugal) for a postdoctoral Grant to M.M.M. Santos.

## References and notes

- (a) Evstigneeva, R. P.; Preobrazhensky, N. A. *Tetrahedron* **1958**, *4*, 223. (b) van Tamelen, E. E.; Aldrich, P. E.; Hester, J. B., Jr. *J. Am. Chem. Soc.* **1959**, *81*, 6214. (c) Winterfeldt, E. *Chem. Ber.* **1964**, *97*, 2463. (d) van Tamelen, E. E.; Hester, J. B., Jr. *J. Am. Chem. Soc.* **1969**, *91*, 7342. (e) van Tamelen, E. E.; Placeway, C.; Schiemenz, G. P.; Wright, I. G. *J. Am. Chem. Soc.* **1969**, *91*, 7359. (f) Lögers, M.; Overman, L. E.; Welmaker, G. S. *J. Am. Chem. Soc.* **1995**, *117*, 9139.
- (a) Amat, M.; Cantó, M.; Llor, N.; Ponzó, V.; Pérez, M.; Bosch, J. *Angew. Chem., Int. Ed.* **2002**, *41*, 335. (b) Amat, M.; Bassas, O.; Pericàs, M. A.; Pastó, M.; Bosch, J. *Chem. Commun.* **2005**, 1327. (c) Bassas, O.; Llor, N.; Santos, M. M. M.; Griera, R.; Molins, E.; Amat, M.; Bosch, J. *Org. Lett.*, **2005**, *7*, 0000.
- For a recent review, see: Pellissier, H. *Tetrahedron* **2003**, *59*, 8291.

4. Luckes, R.; Palecek, J. *Coll. Czech. Chem. Commun.* **1964**, *29*, 1073.
5. Chow, H.-F.; Fleming, I. *J. Chem. Soc., Perkin Trans. 1* **1998**, 2651. We used *t*-BuMe<sub>2</sub>SiCl instead of Me<sub>3</sub>SiCl as described in the original procedure.
6. (a) Evans, D. A.; Ellman, J. A. *J. Am. Chem. Soc.* **1989**, *111*, 1063. (b) Fujii, N.; Otaka, A.; Ikemura, O.; Akaji, K.; Funakoshi, S.; Hayashi, Y.; Kuroda, Y.; Yajima, H. *J. Chem. Soc., Chem. Commun.* **1987**, 274.
7. The conjugate addition of the lithium enolates derived from methyl or *tert*-butyl acetate, or methyl 1,3-dithiolane-2-carboxylate to **9** was also unsuccessful.
8. (a) Lipshutz, B. H.; Harvey, D. F. *Synth. Commun.* **1982**, *12*, 267. (b) Roush, W. R.; Sciotti, R. J. *J. Am. Chem. Soc.* **1994**, *116*, 6457.
9. (a) Krapcho, A. P. *Synthesis* **1982**, 805. (b) Krapcho, A. P. *Synthesis* **1982**, 893.
10. (a) Heffner, R. J.; Jiang, J.; Joullié, M. M. *J. Am. Chem. Soc.* **1992**, *114*, 10181. (b) Flanagan, D. M.; Joullié, M. M. *Synth. Commun.* **1990**, *20*, 459. (c) Compagnone, R. S.; Rapoport, H. *J. Org. Chem.* **1986**, *51*, 1713. (d) Backeberg, O. G.; Staskun, B. *J. Chem. Soc.* **1962**, 3961.
11. For a similar preparation of the methyl ester analog of **16**, see Ref. **1e**.
12. (a) Moreno-Mañas, M.; Ribas, J.; Virgili, A. *J. Org. Chem.* **1988**, *53*, 5328. (b) Moreno-Mañas, M.; Prat, M.; Ribas, J.; Virgili, A. *Tetrahedron Lett.* **1988**, *29*, 581. (c) Prat, M.; Moreno-Mañas, M. *Tetrahedron* **1988**, *44*, 7205.
13. Sundberg, R. J.; Holcombe, F. O., Jr. *J. Org. Chem.* **1969**, *34*, 3273.
14. Cuvigny, T.; Normant, H. *Bull. Soc. Chim. Fr.* **1961**, 2423.
15. (a) Sells, T. B.; Nair, V. *Tetrahedron* **1994**, *50*, 117. (b) Samu, E.; Huszthy, P.; Somogyi, L.; Hollósi, M. *Tetrahedron: Asymmetry* **1999**, *10*, 2775. (c) Kim, D.; Lee, J.; Chang, J.; Kim, S. *Tetrahedron* **2001**, *57*, 1247.
16. Lehnert, W. *Tetrahedron Lett.* **1970**, 4723.

# Asymmetric total synthesis of B-ring modified (–)-epicatechin gallate analogues and their modulation of $\beta$ -lactam resistance in *Staphylococcus aureus*

James C. Anderson,<sup>a,\*</sup> Catherine Headley,<sup>a</sup> Paul D. Stapleton<sup>b</sup> and Peter W. Taylor<sup>b,\*</sup>

<sup>a</sup>School of Chemistry, University of Nottingham, Nottingham, NG7 2RD, UK

<sup>b</sup>Microbiology Group, School of Pharmacy, University of London, 29-39 Brunswick Square, London, WC1, 1AX, UK

Received 20 April 2005; revised 10 May 2005; accepted 26 May 2005

Available online 20 June 2005

**Abstract**—Two enantiomerically pure B-ring modified analogues of (–)-epicatechin gallate were synthesised and their modulation of  $\beta$ -lactam resistance using three strains of methicillin resistant *Staphylococcus aureus* (BB 568, EMRSA-15 and EMRSA-16) evaluated. Sub-inhibitory concentrations (12.5 and 25 mg/L) of the two analogues fully sensitised each of the three MRSA strains to oxacillin, reducing the MIC to less than 0.5 mg/L, identical to levels achieved with ECg. Lower concentrations demonstrated that the position and degree of hydroxylation of the B-ring is important for activity.

© 2005 Elsevier Ltd. All rights reserved.

## 1. Introduction

The benefits to health of green tea (*Camellia sinensis*) are well documented<sup>1</sup> and are attributable, in the main, to polyphenolic constituents that include (–)-epicatechin (EC), (–)-epigallocatechin (EGC), (–)-epicatechin gallate (ECg) and (–)-epigallocatechin gallate (EGCg), the four most abundant catechins present in green tea (~10% of dry weight, Fig. 1).<sup>2</sup> In addition to their capacity to inhibit the development of tumours,<sup>3</sup> catechins possess weak antibacterial properties<sup>4</sup> and catechin gallates are able to reduce the resistance of the opportunistic human pathogen *Staphylococcus aureus* to a wide spectrum of  $\beta$ -lactam antibiotics, such as methicillin, oxacillin and flucloxacillin.<sup>5</sup> Strains of methicillin-resistant *S. aureus* (MRSA) have emerged in recent years as a major cause of hospital-acquired infection and the difficulty in treating these infections is compounded by the fact that they are often also resistant to a wide range of other antibiotics.<sup>6</sup> The recent introduction of two novel antibacterial agents, quinupristin/dalfopristin and linezolid, has provided efficacious and safe therapeutic options for MRSA but there remains an urgent need for new treatments of these infections, in particular with agents that suppress or abrogate the emergence of drug resistance.

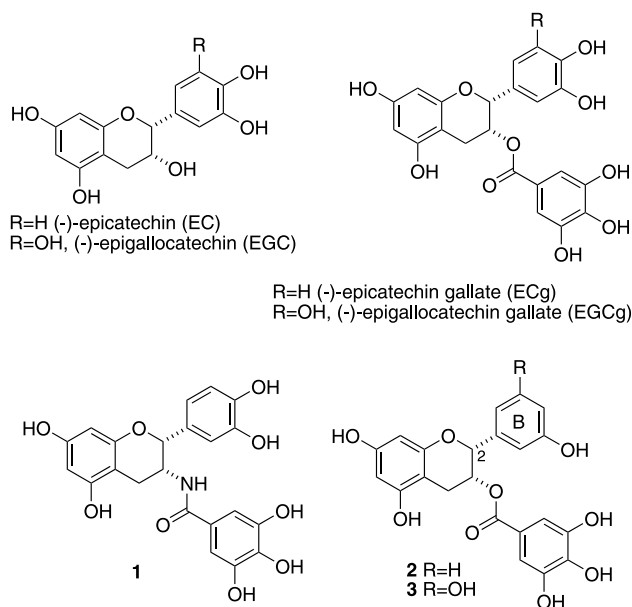
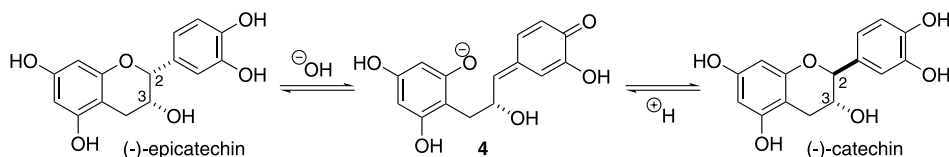


Figure 1.

The resistance modifying capacity of catechin gallates raises the possibility that such molecules could be used in combination with  $\beta$ -lactam agents that are currently of limited use in the treatment of MRSA infections. Naturally occurring catechin gallates, such as the potent modifier ECg,<sup>7</sup> are rapidly degraded in vivo to inactive products due

**Keywords:** Epicatechin gallate; Asymmetric synthesis; Oxacillin; MRSA.  
\* Corresponding authors. Tel.: +44 1159514194; fax: +44 1159513564 (J.C.A.); fax: +44 2077535867 (P.W.T.); e-mail addresses: j.anderson@nottingham.ac.uk; peter.taylor@ulsop.ac.uk



Scheme 1.

to the presence of esterase-susceptible linkage groups.<sup>8</sup> In addition, ECg and other catechin gallates are also known to undergo C-2 epimerisation in hot water or dilute hydroxide.<sup>9–11</sup> We have determined that the presence of the galloyl moiety is essential for  $\beta$ -lactam resistance modification by ECg.<sup>7</sup> In order to prevent the esterase-mediated removal of the galloyl moiety from catechin gallates, the initial step in the metabolism of these molecules, we have designed, synthesised and evaluated an amide ECg analogue **1** (Fig. 1) in which the hydrolytically susceptible ester bond was replaced with an inherently more stable amide linkage.<sup>12</sup> This compound reduced the oxacillin resistance of MRSA strains to levels that are comparable to those achieved with ECg.<sup>12</sup> In order to further improve the pharmacological profile of ECg, we have examined the effect of the degree of hydroxylation of the B-ring (Fig. 1) on modification of  $\beta$ -lactam resistance in MRSA: although the mechanism of modification is at present only partially understood, it is likely to involve a reduction in efficiency of membrane-associated cell wall synthesis as a result of intercalation of ECg into the staphylococcal cytoplasmic membrane.<sup>13</sup> Recent work has shown that catechins in the nanomole range are able to modulate the structure and function of model membranes due to their capacity to partition into the phospholipid palisade.<sup>14</sup> Galloyl catechins bound more avidly than either EC or EGC to small unilamellar vesicles produced from phosphatidyl choline, and ECg had a greater affinity for the membrane bilayer than EGCg.<sup>14</sup> The relative affinity of catechins for membrane bilayers is reflected in their capacity to modulate  $\beta$ -lactam resistance and their partition coefficients in *n*-octanol-saline. ECg differs from EGCg only by the absence of a hydroxyl function at one of the other *meta*- position of the B-ring; we surmised that a further reduction in the degree of hydroxylation of the B-ring would enhance anti-MRSA effects by increasing the affinity of these analogues for lipid bilayers.

The facility for epimerization may also be due to the extent of hydroxylation of the aromatic B-ring. Rate measurements of epimerization of tea catechins in tea infusion indicated that the presence of hydroxyl groups on the B-ring of catechin structures promoted epimerization.<sup>11</sup> The most reasonable mechanism for epimerization involves the intermediate quinone methide **4**, proposed by Mehta and Whalley,<sup>15</sup> which is also supported by the fact that epimerization only affects the stereochemistry at C-2. (Scheme 1).<sup>16</sup> It has also been noted that under basic reaction conditions epimerization of epicatechin type molecules (2,3-*cis*) reaches an equilibrium in which the catechin type skeleton (2,3-*trans*) predominates.<sup>10</sup>

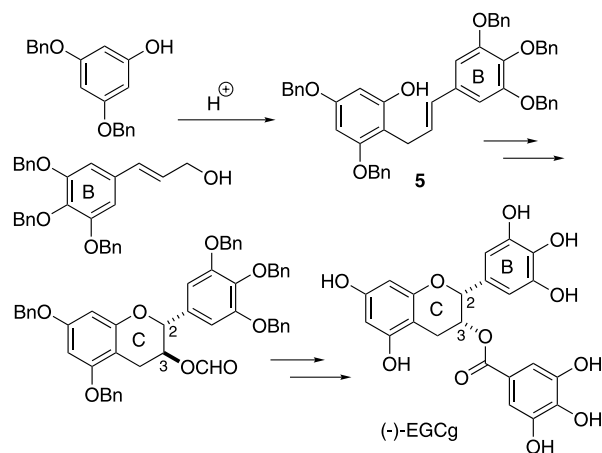
We proposed that a further reduction in the degree of hydroxylation of the B-ring would enhance anti-MRSA effects by increasing the affinity of these analogues for lipid

bilayers. Specifically, modified ECg molecule **2** that did not possess the *para*-hydroxyl group would also be less prone to epimerization via a quinone methide-like intermediate due to the removal of this anchimeric substituent. We have synthesized this compound (**2**) in enantiomerically pure form, as well as the 3,5-dihydroxy B-ring (**3**) to compare their capacity to suppress the resistance of MRSA isolates to the  $\beta$ -lactam antibiotic oxacillin.

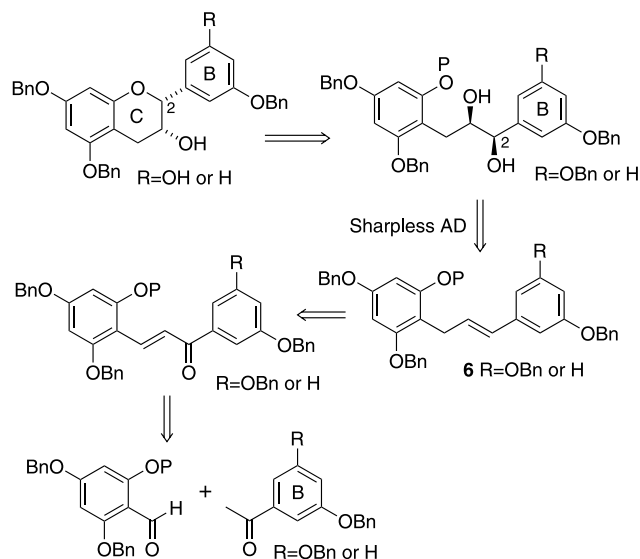
## 2. Chemical synthesis

We desired a flexible total synthesis that would allow access to analogues of ECg with respect to the number and location of the hydroxyl groups and also to individual stereoisomers. During the initial stages of our work there appeared two total syntheses of EGCg,<sup>17,18</sup> both forming the gallate ester bond at a late stage in the synthesis. The synthesis<sup>15</sup> by Li and Chan was enantioselective based upon the Sharpless asymmetric dihydroxylation<sup>19</sup> of **5** followed by subsequent cyclisation via an *ortho* ester to give the C-ring catechin 2,3-*trans* stereochemistry (Scheme 2).<sup>15</sup> Using a published stereochemical inversion of the C-3 hydroxyl of catechin derivatives,<sup>20</sup> oxidation of the C-3 hydroxyl group and reduction furnished the epicatechin 2,3-*cis* stereochemistry.

Our attempts at an analogous route using a 3-hydroxylated or 3,5-dihydroxylated B-ring failed at the acid induced coupling stage in an attempt to give the analogue of **5**. Presumably the *para*-oxygen functionality is important for the success of this coupling. It was also noted in Li and Chan's work<sup>17</sup> that under cyclisation conditions to give directly the *cis*-2,3 C-ring, the integrity at the benzylic C-2 position was compromised by the oxygenation of the B-ring, again most probably due to the *para*-hydroxyl group. We decided to access **6**, the 3-hydroxylated and 3,5-dihydroxylated B-ring analogue of **5** (Scheme 3), by using an aldol



Scheme 2.

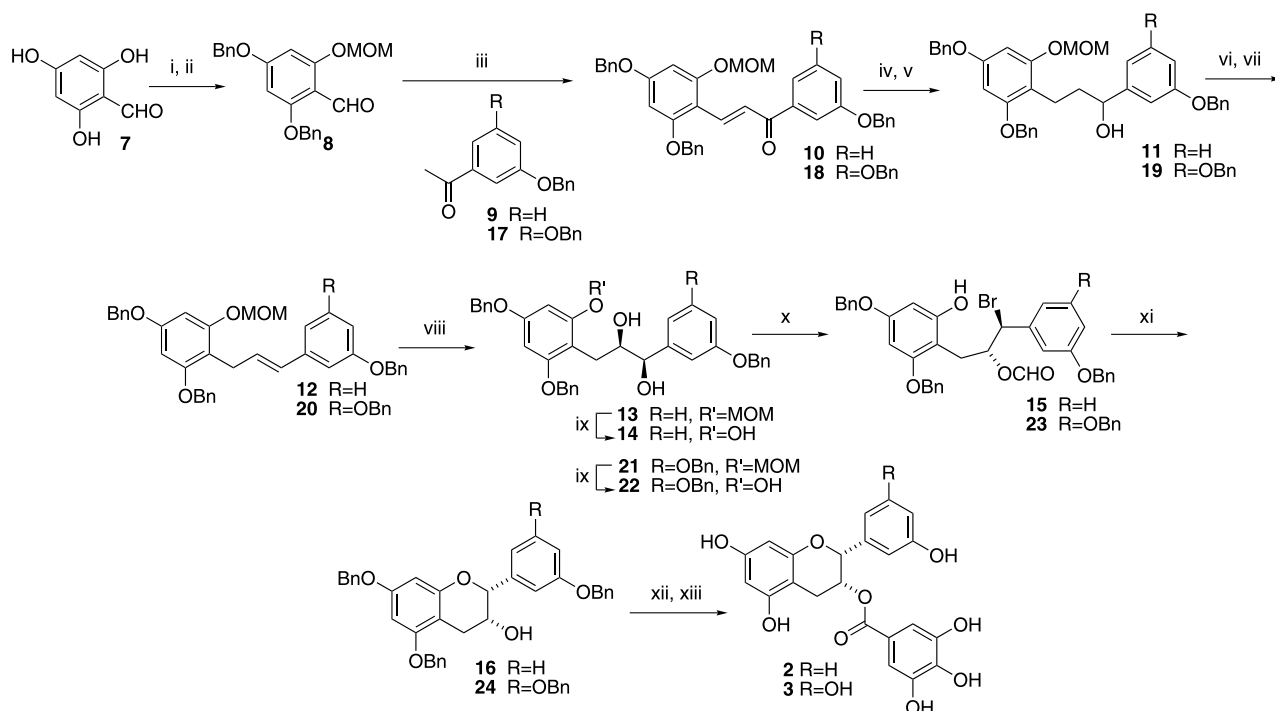


Scheme 3. Retrosynthesis.

dehydration/reduction protocol. We were confident that the reported loss of stereochemical integrity at C-2 upon cyclisation to form the C-ring would be impeded due to the lack of B-ring *para*-oxygenation. Both of the published syntheses<sup>17,18</sup> had shown that global debenzoylation was high yielding and so we opted to use the benzyl protecting group except for the orthogonal protecting group P. Our retrosynthesis is detailed in Scheme 3.

Selective 2,4-benzoylation<sup>21</sup> of 2,4,6-trihydroxybenzaldehyde (**7**), by treatment with  $K_2CO_3$  and BnBr, was followed by standard MOM protection of the remaining 6-hydroxyl group to give **8** (Scheme 4). We planned that the MOM group would be orthogonal to the benzyl groups and could be selectively removed under acidic conditions that may facilitate cyclisation to form the C-ring. Condensation<sup>22</sup> of **8** with 3-benzoyloxyacetophenone (**9**) gave enone **10** uneventfully in good yield. Reduction of the enone system to the alcohol and subsequent elimination to give the alkene was surprisingly capricious. Protocols for one step reduction<sup>23</sup> of the enone to the alcohol gave mixtures of reduction products and it was more efficient for material throughput to perform a two step reduction of the enone alkene with catechol borane<sup>24</sup> and then the resultant ketone with  $NaBH_4$ . Direct dehydration using acidic reagents was prohibited due to the lability of the MOM ether. The use of activating dehydration reagents; Burgess' reagent and DCC,<sup>25</sup> were slow and unable to give complete conversion. Elimination was achieved by conversion of the benzyl alcohol **11** to the corresponding bromide and then heating in the presence of DBU. The overall reductive isomerisation of enone **10** to alkene **12** was achieved in a four steps with an overall yield of 42% (Scheme 4).

Dihydroxylation of **12** using AD-mix- $\beta$ <sup>®19</sup> gave **13** with an initial 75% ee (65%).<sup>26</sup> Recrystallisation gave a 48% isolated yield of enantiomerically pure **13**. Removal of the MOM ether (3 M HCl) gave triol **14**, but attempts at direct acid catalysed cyclisation (3 M HCl) proved impossible.



**Scheme 4.** Reagents: (i)  $K_2CO_3$ , BnBr, DMF, rt, 16 h, 69%; (ii) NaH, MOMCl, THF 0 °C to rt, 88%; (iii) KOH aq. (50%), EtOH, THF, rt, 16 h, R=H 69%, R=OBn 94%; (iv) Catechol borane, THF, -78 °C to rt, R=H 86% crude, R=OBn 86% crude; (v)  $NaBH_4$ , MeOH, rt, R=H 99% crude, R=OBn 99% crude; (vi)  $PPh_3$ ,  $Br_2$ ,  $Et_3N$ ,  $CH_2Cl_2$ , 0 °C to rt, R=H 85%, R=OBn 99%; (vii) DBU, PhMe, 110 °C, 16 h, R=H 57%, R=OBn 53%; (viii) AD-mix- $\beta$ <sup>®</sup>, *t*-BuOH,  $H_2O$ ,  $MeSO_2NH_2$ , 0 °C, 5 days, R=H 65% @ 75% ee, 48% @ >99% ee, R=OBn 82% @ 75% ee, 46% @ >99% ee; (ix) HCl, MeOH,  $Et_2O$ , reflux, 5 h, R=H 100% crude, R=OBn 100% crude; (x)  $HC(OAc)_3$ , PPTS cat.,  $CH_2Cl_2$ , rt; w/up then AcBr,  $CH_2Cl_2$ , rt, R=H 88% crude, R=OBn 91% crude; (xi)  $K_2CO_3$ , acetone, rt, 5 h; w/up then  $K_2CO_3$ , MeOH, rt, 16 h, R=H 61%, R=OBn 45%; (xii) DCC, tri-OBn gallic acid, DMAP,  $CH_2Cl_2$ , rt, 16 h, R=H 64%, R=OBn 67%; (xiii)  $H_2$ , 10% Pd(OH)<sub>2</sub>/C, EtOAc, rt, 12 h, R=H 94%, R=OH 37%.



Presumably similar cyclisations in the literature<sup>17,27</sup> have relied upon the ring B para-hydroxyl group activating the benzylic hydroxyl group toward cyclisation. Although, this meant we had to adopt an alternative and longer synthetic route to form ring C, this was again circumstantial evidence to support our hypothesis that ECg analogues **2** and **3** would be more stable toward possible epimerization (Scheme 1). Cyclisation to the 2,3-*cis* substituted C-ring followed Li and Chan's protocol<sup>17</sup> whereby the corresponding cyclic orthoformate of **14** was ring opened with acetyl bromide<sup>28</sup> to give benzylic bromide **15** as a single diastereoisomer by <sup>1</sup>H NMR. Immediate treatment with K<sub>2</sub>CO<sub>3</sub> caused cyclisation and deformylation to give the *cis*-2,3 substituted C-ring compound **16**. Completion of the synthesis was achieved by DCC induced coupling with 3,4,5-tribenzyloxy benzoic acid (55%) and subsequent global debenylation by hydrogenolysis with Pd(OH)<sub>2</sub> catalysis (48%) to give the enantiomerically pure 3-hydroxy B-ring analogue (–)-**2** of ECg. The stereochemical integrity of the 2,3-*cis* substitution was proven from the multiplicity of the <sup>1</sup>H NMR signal of C–1H (**2**,  $\delta$  5.27, s) that compares favourably with the analogous signal in (–)-EGCg ( $\delta$  5.36, d,  $J=1.2$  Hz)<sup>17</sup> and 5,7,3',4'-tetra-*O*-benzyl-(–)-epicatechin ( $\delta$  4.91, s).<sup>29</sup> Contrasting signals in similar molecules possessing the 2,3-*trans* relationship also support this; 5,7,3',4',5'-penta-*O*-benzyl-gallocatechin ( $\delta$  4.65, d,  $J=8.1$  Hz)<sup>17</sup> and 5,7,3',4'-tetra-*O*-benzyl-(+)-catechin ( $\delta$  4.63, d,  $J=8.5$  Hz).<sup>21</sup> Absolute stereochemistry was assumed from the Sharpless mnemonic for AD-mix- $\beta$ <sup>19</sup> and the fact that the final compound exhibits the same sense of optical rotation as naturally occurring (–)-ECg.

Repetition of this synthesis starting with 3,5-dibenzyloxyacetophenone **17** led to the enantiomerically pure 3,5-dihydroxy B-ring analogue (–)-**3** of ECg uneventfully in similar yield. The 2,3-*cis* stereochemical relationship was again verified from the multiplicity of the <sup>1</sup>H NMR signal of C–1H (**3**,  $\delta$  4.99, s) that compares favourably with the above data.

### 3. Microbiological evaluation

With the B-ring modified analogues **2** and **3** in hand, their efficacy as modulators for  $\beta$ -lactam resistance in *S. aureus* was evaluated by determining their capacity to reduce the minimum inhibitory concentration (MIC) of oxacillin against MRSA strains BB 568, EMRSA-15 and EMRSA-16 (Table 1). The monohydroxylated B-ring analogue **2** possessed little or no intrinsic antibacterial activity against the three MRSA strains and in this respect was comparable to ECg (Table 1). Interestingly, the 3,5-dihydroxy B-ring analogue **3** showed weak to moderate anti-staphylococcal activity that was significantly higher than that shown by ECg and analogue **2**, suggesting that the position of hydroxyl groups on the B-ring may influence the intrinsic antibacterial activity of ECg analogues. Sub-inhibitory concentrations (6.25, 12.5 and 25 mg/L) of both compounds were effective in reducing the MIC of all three strains examined. At a concentration of 25 mg/L, ECg and the two analogues (**2** and **3**) fully sensitised each of the three MRSA strains to oxacillin, reducing the MICs to less than 0.5 mg/L, a figure well below the clinically-relevant breakpoint for

Table 1. Antibacterial activity of ECg, **2** and **3** and in combination with oxacillin against methicillin-resistant *S. aureus* (MRSA) strains

MRSA Strain	MIC (mg/L) <sup>a</sup>			Oxacillin MIC (mg/L) <sup>a</sup>						
	ECg	<b>2</b>	<b>3</b>	ECg <sup>b</sup>		<b>2</b> <sup>b</sup>		<b>3</b> <sup>b</sup>		
				6.25	12.5	6.25	12.5	6.25	12.5	25
BB 568	256	>128	128	1	≤0.5	16	2	≤0.5	16	1
EMRSA-15	256	>128	64	≤0.5	≤0.5	2	≤0.5	≤0.5	2	≤0.5
EMRSA-16	128	128	32	≤0.5	≤0.5	32	1	≤0.5	64	≤0.5

<sup>a</sup> MIC's were determined in Mueller-Hinton Broth + 2% salt at 35 °C after 24 h incubation.

<sup>b</sup> Fixed concentrations of the compound were used (6.25, 12.5 and 25 mg/L).

$\beta$ -lactam antibiotics. At 6.25 mg/L of catechin gallate, the lowest concentration used in this study, both the mono-hydroxylated B-ring analogue and the 3,5-dihydroxy B-ring analogue were less potent than the natural compound (Table 1).

## 4. Conclusion

A flexible asymmetric synthesis of two B-ring modified ECg analogues has been developed that originates from an aldol dehydration/reduction protocol to form a key A,B-ring styrene precursor. We believe this strategy could be used to synthesise other B and A ring modified ECg analogues for biological evaluation. The control of absolute stereochemistry by the Sharpless asymmetric dihydroxylation, and subsequent stereoselective cyclisation to form the C-ring is an analogous strategy to that reported by Li and Chan<sup>17</sup> in their synthesis of EGCg. As demonstrated by them this route can provide either enantiomer of the desired analogues. Biological evaluation showed that at concentrations of 12.5 and 25 mg/L, ECg and the two B-ring analogues (**2** and **3**) fully sensitised each of the three MRSA strains to oxacillin, reducing the MICs to less than 0.5 mg/L. Results at lower concentration of catechin suggests that not only the degree, but the relative position of hydroxylation of the B-ring is important for optimal interaction with biological membranes in MRSA. We are currently investigating the intrinsic stability of ECg, **2** and **3**, and their capacity to intercalate into staphylococcal membranes, the results of which will be reported in due course.

## 5. Experimental

### 5.1. General

Our general experimental details have been reported.<sup>30</sup>

**5.1.1. 4,6-Dibenzoyloxy-2-O-methoxymethylbenzaldehyde (8).** To a stirred solution of aldehyde **7** (5.0 g, 35 mmol) in DMF (50 mL) was added  $K_2CO_3$  (9.7 g, 70 mmol) followed by BnBr (8.4 mL, 70 mmol) and the mixture was stirred at rt overnight. The mixture was then diluted with  $Et_2O$  (100 mL) and washed with  $H_2O$  (100 mL), dried ( $MgSO_4$ ), filtered and concentrated in vacuo to yield a yellow solid, which was recrystallised from  $Et_2O$  to furnish the 4,6-dibenzyl protected aldehyde as a pale yellow semi-solid (8.1 g, 69%); IR  $\nu_{max}$  2922, 1635  $cm^{-1}$ ;  $^1H$  NMR (400 MHz,  $CDCl_3$ )  $\delta$  5.04 (s, 2H,  $OCH_2Ph$ ), 5.06 (s, 2H,  $OCH_2Ph$ ), 6.14 (d, 1H,  $J=2.1$  Hz,  $ArH$ ), 6.17 (d, 1H,  $J=2.1$  Hz,  $ArH$ ), 7.37–7.50 (m, 10H,  $ArH$ ), 10.24 (s, 1H,  $CHO$ );  $^{13}C$  NMR (100 MHz,  $CDCl_3$ )  $\delta$  70.9, 80.1, 92.8, 94.6, 106.8, 127.5, 127.9, 128.0, 128.1, 128.8, 128.9, 129.0, 129.2, 129.3, 136.1, 163.1, 166.6, 166.8, 192.4; MS (ES,  $m/z$ ) 334 ( $M^+$ , 20%), 91 ( $Bn^+$ , 100%); HRMS (ES,  $m/z$ ) found 334.1215,  $C_{21}H_{18}O_4$  requires 334.1205.

To a stirred solution of NaH (2.6 g, 66 mmol) in THF (100 mL) at 0 °C was added the 4,6-dibenzyl protected aldehyde (11 g, 33 mmol), in THF (30 mL). After 5 min MOMCl (5.0 mL, 33 mmol) was added and the mixture

allowed to warm to rt. Brine (5.0 mL) was then added and the reaction partitioned between  $Et_2O$  (100 mL) and  $H_2O$  (100 mL), the organic layer was dried ( $MgSO_4$ ), filtered and concentrated in vacuo to yield aldehyde **8** as a brown oil (11 g, 88%); IR  $\nu_{max}$  3063, 3031, 2875  $cm^{-1}$ ;  $^1H$  NMR (400 MHz,  $CDCl_3$ )  $\delta$  3.53 (s, 3H,  $OCH_2OCH_3$ ), 5.09 (s, 2H,  $OCH_2Ph$ ), 5.15 (s, 2H,  $OCH_2Ph$ ), 5.27 (s, 2H,  $OCH_2OCH_3$ ), 6.30 (d, 1H,  $J=2.1$  Hz,  $ArH$ ), 6.48 (d, 1H,  $J=2.1$  Hz,  $ArH$ ), 7.35–7.48 (m, 10H,  $ArH$ ), 10.49 (s, 1H,  $CHO$ );  $^{13}C$  NMR (100 MHz,  $CDCl_3$ )  $\delta$  56.9, 70.8, 71.0, 94.5, 95.1, 95.4, 110.5, 127.4, 127.5, 128.1, 128.4, 128.8, 128.9, 129.0, 129.1, 129.2, 136.2, 136.5, 161.8, 163.3, 165.3, 188.0; MS (ES,  $m/z$ ) 378 ( $M^+$ , 10%), 91 ( $Bn^+$ , 100%); HRMS (ES,  $m/z$ ) found 378.1456,  $C_{23}H_{22}O_5$  requires 378.1467.

**5.1.2. 3',4,6-Tribenzoyloxy-2-O-methoxymethyl-E-retrochalcone (10).** To a solution of acetophenone **9** (6.9 g, 32 mmol) in EtOH (100 mL) was added aq. KOH solution (10 mL of 50% m/v) and the mixture stirred at rt for 20 min. A solution of benzaldehyde **8** (11 g, 29 mmol) in THF (50 mL) was then added, and the mixture stirred overnight. The precipitate, which had formed was then filtered and washed with  $Et_2O$  to yield chalcone **10** (12 g, 69%), as a fine yellow powder; mp 108–110 °C; IR  $\nu_{max}$  3064, 3032, 2933, 1601, 1566, 1159  $cm^{-1}$ ;  $^1H$  NMR (500 MHz,  $CDCl_3$ )  $\delta$  3.60 (s, 3H,  $OCH_2OCH_3$ ), 5.16 (s, 2H,  $OCH_2Ph$ ), 5.17 (s, 2H,  $OCH_2Ph$ ), 5.19 (s, 2H,  $OCH_2Ph$ ), 5.35 (s, 2H,  $OCH_2OCH_3$ ), 6.46 (d, 1H,  $J=2.2$  Hz,  $ArH$ ), 6.62 (d, 1H,  $J=2.2$  Hz,  $ArH$ ), 7.19–7.21 (m, 1H,  $ArH$ ), 7.28–7.30 (m, 2H,  $ArH$ ), 7.42–7.57 (m, 15H,  $ArH$ ), 7.66 (d, 1H,  $ArH$ ), 7.99 (d, 1H,  $J=16$  Hz,  $ArCH=CHCO$ ), 8.41 (d, 1H,  $J=16$  Hz,  $ArCH=CHCO$ );  $^{13}C$  NMR (100 MHz,  $CDCl_3$ )  $\delta$  56.9, 70.5, 70.7, 71.4, 94.5, 94.9, 95.3, 108.2, 114.0, 119.9, 121.7, 122.5, 128.1, 128.5, 128.6, 128.7, 128.8, 129.0, 129.1, 129.3, 129.8, 136.2, 136.5, 136.7, 137.2, 140.9, 159.4, 159.9, 161.3, 162.5, 191.5; MS (ES,  $m/z$ ) 586 ( $M^+$ , 7%), 91 ( $Bn^+$ , 100%); HRMS (ES,  $m/z$ ) found 586.2340,  $C_{38}H_{34}O_6$  requires 586.2355.

**5.1.3. 1-(3'-Benzoyloxyphenyl)-3-(2''-O-methoxymethyl-4'',6''-dibenzoyloxyphenyl)propan-1-ol (11).** Catechol borane (1 M solution in THF, 10 mL, 10 mmol) was added dropwise to a stirred solution of chalcone **10** (5.0 g, 8.5 mmol) in THF (80 mL) at –78 °C. The mixture was allowed to warm to rt and stirred for a further 1 h before acetone (10 mL) and sat. aq.  $NH_4Cl$  (10 mL) were added. The mixture was extracted into  $Et_2O$  ( $2 \times 50$  mL), the combined organic layers washed with 2 M NaOH (50 mL) and brine (50 mL), then dried ( $MgSO_4$ ) filtered, and concentrated in vacuo to afford the corresponding ketone (4.3 g, 86%). The crude ketone was immediately dissolved in methanol (30 mL) and  $NaBH_4$  (310 mg, 8.0 mmol) was added at rt. The mixture was stirred for 1 h before all volatile material was removed in vacuo,  $H_2O$  (50 mL) added and the mixture extracted into  $Et_2O$  ( $3 \times 30$  mL). The combined organic layers were dried ( $MgSO_4$ ) filtered, and concentrated in vacuo to give alcohol **11** (5.0 g, 99%) as a pale yellow solid; mp 120–122 °C; IR  $\nu_{max}$  3500, 2931, 1604  $cm^{-1}$ ;  $^1H$  NMR (400 MHz,  $CDCl_3$ )  $\delta$  1.95–2.08 (m, 2H,  $ArCH_2CH_2CHOH$ ), 2.90–2.92 (m, 2H,  $ArCH_2CH_2CHBr$ ), 3.52 (s, 3H,  $OCH_2OCH_3$ ), 4.61 (dd, 1H,  $J=8.8$ , 4.3 Hz,  $ArCH_2CH_2CHOH$ ), 5.07 (s, 2H,  $OCH_2Ph$ ), 5.08 (s, 2H,  $OCH_2Ph$ ), 5.09 (s, 2H,  $OCH_2Ph$ ), 5.23 (s, 2H,

OCH<sub>2</sub>OCH<sub>3</sub>), 6.41 (d, 1H, *J*=2.2 Hz, *ArH*), 6.55 (d, 1H, *J*=2.2 Hz, *ArH*), 6.90 (ddd, 1H, *J*=8.2, 2.6, 0.8 Hz, *ArH*), 6.93 (d, 1H, *J*=8.2 Hz, *ArH*), 7.06 (apt, 1H, *J*=2.6 Hz, *ArH*), 7.26 (t, 1H, *J*=8.2 Hz, *ArH*), 7.35–7.50 (m, 15H, *ArH*); <sup>13</sup>C NMR (100 MHz, CDCl<sub>3</sub>) δ 19.7, 39.3, 56.7, 70.3, 70.7, 70.9, 73.4, 94.8, 95.0, 95.3, 112.1, 112.8, 113.9, 118.9, 127.7, 128.0, 128.1, 128.3, 128.4, 128.5, 129.0, 129.1, 129.7, 137.3, 137.6, 146.9, 156.9, 158.3, 158.9, 159.3; MS (ES, *m/z*) 613 (M<sup>+</sup>+Na, 80%), 523 (M<sup>+</sup>–67, 100%); HRMS (ES, *m/z*) found 613.2578, C<sub>38</sub>H<sub>38</sub>O<sub>6</sub>Na requires 613.2566.

**5.1.4. (*E*)-1-(3'-Benzyloxyphenyl)-3-(2''-O-methoxymethyl-4''',6'''-dibenzoyloxyphenyl)propene (12).** To a stirred solution of PPh<sub>3</sub> (1.4 g, 5.4 mmol) in CH<sub>2</sub>Cl<sub>2</sub> (20 mL) at 0 °C was added Br<sub>2</sub> (0.30 mL, 5.4 mmol) dropwise and after 5 min, Et<sub>3</sub>N (0.90 mL, 9.7 mmol) was added and the mixture stirred for a further 5 min. A solution of the alcohol **11** (2.1 g, 3.6 mmol) in CH<sub>2</sub>Cl<sub>2</sub> (10 mL) was then added dropwise and the mixture allowed to warm to rt. After 2 h the mixture was concentrated in vacuo and purified by flash chromatography (neutral alumina, 50% Et<sub>2</sub>O/hexanes) to afford the bromide as a yellow oil (2.0 g, 85%); IR ν<sub>max</sub> 2931, 1594, 1150 cm<sup>-1</sup>; <sup>1</sup>H NMR (400 MHz, CDCl<sub>3</sub>) δ 2.50–2.58 (m, 2H, ArCH<sub>2</sub>CH<sub>2</sub>CHBr), 2.74–2.76 (m, 1H, ArCH<sub>2</sub>CH<sub>2</sub>CHBr), 2.89–2.93 (m, 1H, ArCH<sub>2</sub>CH<sub>2</sub>CHBr), 3.52 (s, 3H, OCH<sub>2</sub>OCH<sub>3</sub>), 5.05–5.09 (m, 7H, 3×OCH<sub>2</sub>Ph and ArCH<sub>2</sub>CH<sub>2</sub>CHBr), 5.21 (dd, 2H, *J*=8.0, 6.7 Hz, OCH<sub>2</sub>OCH<sub>3</sub>), 6.37 (d, 1H, *J*=2.3 Hz, *ArH*), 6.53 (d, 1H, *J*=2.2 Hz, *ArH*), 6.89 (ddd, 1H, *J*=8.2, 2.5, 0.8 Hz, *ArH*), 7.00 (d, 1H, *J*=7.8 Hz, *ArH*), 7.07 (t, 1H, *J*=2.2 Hz, *ArH*), 7.20–7.23 (m, 1H, *ArH*), 7.33–7.47 (m, 15H, 15×*ArH*); <sup>13</sup>C NMR (100 MHz, CDCl<sub>3</sub>) δ 22.5, 39.8, 56.0, 56.5, 56.6, 70.5, 70.6, 70.7, 94.6, 94.9, 95.1, 111.8, 114.7, 120.5, 127.6, 127.7, 127.9, 128.0, 128.1, 128.3, 128.5, 129.0, 130.0, 137.3, 137.4, 137.6, 144.3, 157.0, 158.3, 159.0, 159.3; MS (FAB, *m/z*) 654 (M<sup>+</sup>, 100%); HRMS (FAB, *m/z*) found 654.1809, C<sub>38</sub>H<sub>37</sub>O<sub>5</sub>Br requires 654.1804.

A solution of bromide (3.3 g, 5.0 mmol) in DBU and toluene (25 mL, 4:1), was heated to reflux overnight. The mixture was then allowed to cool and extracted into Et<sub>2</sub>O (3×25 mL). The combined organic layers were dried (MgSO<sub>4</sub>), filtered and concentrated in vacuo. Purification by flash chromatography (Silica, 20% Et<sub>2</sub>O/hexanes) gave styrene **12** (1.68 g, 57%) as a colourless oil; IR ν<sub>max</sub> 3031, 2929, 1592 cm<sup>-1</sup>; <sup>1</sup>H NMR (400 MHz, CDCl<sub>3</sub>) δ 3.53 (s, 3H, OCH<sub>2</sub>OCH<sub>3</sub>), 3.63–3.64 (m, 2H, ArCH<sub>2</sub>CH=CH), 5.08–5.10 (m, 6H, 3×OCH<sub>2</sub>Ph), 5.24 (s, 2H, OCH<sub>2</sub>OCH<sub>3</sub>), 6.38–6.41 (m, 3H, ArCH<sub>2</sub>CH=CH and *ArH*), 6.55 (d, 1H, *J*=2.3 Hz, *ArH*), 6.95–7.00 (m, 1H, *ArH*), 7.24 (t, 1H, *J*=4.3 Hz, *ArH*), 7.33–7.50 (m, 16H, *ArH*); <sup>13</sup>C NMR (100 MHz, CDCl<sub>3</sub>) δ 27.0, 56.5, 70.3, 70.4, 70.7, 94.7, 95.0, 95.1, 110.9, 112.7, 113.6, 127.7, 127.9, 128.0, 128.1, 128.2, 128.3, 128.5, 129.0, 129.7, 129.8, 130.2, 137.4, 137.6, 140.1, 156.8, 158.3, 159.1, 159.4; MS (ES, *m/z*) 573 (MH<sup>+</sup>, 100%); HRMS (ES, *m/z*) found 573.2556, C<sub>38</sub>H<sub>37</sub>O<sub>5</sub> requires 573.2641.

**5.1.5. (1*R*,2*R*)-1-(3'-Benzyloxyphenyl)-3-(2''-O-methoxymethyl-4''',6'''-dibenzoyloxyphenyl)propane-1,2-diol (13).** To a solution of AD-mix-β<sup>®</sup> (5.0 g) in *t*-BuOH (30 mL) and H<sub>2</sub>O (30 mL) at 0 °C was added methane sulfonamide

(270 mg, 2.9 mmol) followed by styrene **12** (1.5 g, 2.6 mmol) in THF (30 mL) and the mixture stirred at 0 °C for 5 days. Solid sodium sulfite (5 g) was added and the product was extracted into EtOAc (3×30 mL), the combined organics dried (MgSO<sub>4</sub>), filtered and concentrated in vacuo to yield the crude product, which was purified by flash chromatography (Silica, 80% Et<sub>2</sub>O/hexanes) to yield the desired product **13** as a white solid (1.0 g, 65%, 75% ee by HPLC<sup>26</sup>) that was then recrystallised (80% Et<sub>2</sub>O/EtOAc) to give enantiomerically pure **13** (740 mg, 48%); mp 114–116 °C; IR ν<sub>max</sub> 3405, 2964, 2923, 2851, 1605 cm<sup>-1</sup>; <sup>1</sup>H NMR (500 MHz, CDCl<sub>3</sub>) δ 2.60 (br s, 1H, OH), 2.97 (dd, 1H, *J*=14, 5.8 Hz, ArCH<sub>2</sub>CH(OH)CH(OH)), 3.03 (dd, 1H, *J*=14, 8.1 Hz, ArCH<sub>2</sub>CH(OH)CH(OH)), 3.36 (br s, 1H, OH), 3.53 (s, 3H, OCH<sub>2</sub>OCH<sub>3</sub>), 4.02–4.05 (m, 1H, ArCH<sub>2</sub>CH(OH)CH(OH)), 4.60 (d, 1H, *J*=4.8 Hz, ArCH<sub>2</sub>CH(OH)CH(OH)), 5.11–5.13 (m, 6H, 3×OCH<sub>2</sub>Ph), 5.22 (dd, 2H, *J*=11, 6.7 Hz, OCH<sub>2</sub>OCH<sub>3</sub>), 6.47 (d, 1H, *J*=2.2 Hz, *ArH*), 6.58 (d, 1H, *J*=2.2 Hz, *ArH*), 6.98 (dd, 1H, *J*=8.2, 2.0 Hz, *ArH*), 7.03 (d, 1H, *J*=8.2 Hz, *ArH*), 7.15 (apt, 1H, *J*=2.0 Hz, *ArH*), 7.32 (t, 1H, *J*=8.2 Hz, *ArH*), 7.40–7.53 (m, 15H, *ArH*); <sup>13</sup>C NMR (100 MHz, CDCl<sub>3</sub>) δ 27.9, 56.7, 70.4, 70.7, 71.0, 76.1, 76.7, 94.9, 95.1, 95.2, 108.7, 113.8, 114.3, 119.8, 127.7, 128.0, 128.1, 128.4, 128.5, 128.6, 129.0, 129.2, 129.7, 137.2, 137.5, 143.4, 157.2, 158.5, 159.3, 159.4; MS (ES, *m/z*) 629 (M<sup>+</sup>+Na, 100%); HRMS (ES, *m/z*) found 629.2629, C<sub>38</sub>H<sub>38</sub>O<sub>7</sub>Na requires 629.2515; [α]<sub>D</sub> +9.9 (c 0.1, CH<sub>2</sub>Cl<sub>2</sub>, at 21 °C).

**5.1.6. (1*R*,2*R*)-1-(3'-Benzyloxyphenyl)-3-(2''hydroxy-4''',6'''-dibenzoyloxyphenyl)propane-1,2-diol (14).** To a solution of diol **13** (740 mg, 1.2 mmol) in MeOH (10 mL) and Et<sub>2</sub>O (10 mL) was added conc. HCl (5 drops) and the mixture heated at reflux for 5 h. The mixture was then concentrated in vacuo, diluted with EtOAc and washed with H<sub>2</sub>O, the organic layer was dried (MgSO<sub>4</sub>), filtered and concentrated in vacuo to yield the product **14** as a white solid (730 mg, 100%); mp 120–122 °C; IR ν<sub>max</sub> 3436, 2923, 1739 cm<sup>-1</sup>; <sup>1</sup>H NMR (400 MHz, CDCl<sub>3</sub>) δ 2.81 (dd, 1H, *J*=15, 8.5 Hz, ArCH<sub>2</sub>CH(OH)CH(OH)), 2.97 (dd, 1H, *J*=15, 3.8 Hz, ArCH<sub>2</sub>CH(OH)CH(OH)), 4.00–4.04 (m, 1H, ArCH<sub>2</sub>CH(OH)CH(OH)), 4.50 (d, 1H, *J*=6.3 Hz, ArCH<sub>2</sub>CH(OH)CH(OH)), 4.90 (dd, 2H, *J*=14, 12 Hz, OCH<sub>2</sub>Ph), 4.99–5.01 (m, 4H, 2×OCH<sub>2</sub>Ph), 6.26 (d, 1H, *J*=2.3 Hz, *ArH*), 6.31 (d, 1H, *J*=2.3 Hz, *ArH*), 6.88–6.92 (m, 1H, *ArH*), 6.99–7.00 (m, 1H, *ArH*), 7.17–7.20 (m, 2H, *ArH*), 7.33–7.47 (m, 15H, *ArH*); <sup>13</sup>C NMR (100 MHz, CDCl<sub>3</sub>) δ 27.1, 70.4, 70.5, 77.2, 77.3, 93.9, 96.3, 106.7, 119.8, 127.2, 127.3, 128.0, 128.1, 128.4, 128.9, 129.0, 130.1, 137.3, 137.4, 142.6, 157.7, 158.3, 159.3, 159.5; MS (ES, *m/z*) 585 (M<sup>+</sup>+Na, 40%), 563 (MH<sup>+</sup>, 100%); HRMS (ES, *m/z*) found 563.2358, C<sub>36</sub>H<sub>35</sub>O<sub>6</sub> requires 563.2434; [α]<sub>D</sub> –15.6 (c 3.7, CH<sub>2</sub>Cl<sub>2</sub>, at 24 °C).

**5.1.7. (1*S*,2*R*)-1-Bromo-2-formate (15).** To a solution of triol **14** (730 mg, 1.3 mmol) in CH<sub>2</sub>Cl<sub>2</sub> (15 mL) was added trimethyl orthoformate (1.4 mL, 13 mmol) followed by PPTS (5.0 mg) and the mixture stirred at rt for 10 min. The mixture was then washed with satd. aq. NaHCO<sub>3</sub> (10 mL), dried (MgSO<sub>4</sub>), filtered and concentrated to in vacuo. The crude cyclic orthoformate was then redissolved in CH<sub>2</sub>Cl<sub>2</sub> (15 mL), treated with AcBr (0.14 mL, 1.9 mmol) and stirred

for 10 min at rt. The mixture was then washed with satd. aq. NaHCO<sub>3</sub> (10 mL) and concentrated in vacuo to afford bromo formate **15** as a brown foam (750 mg, 88%). This compound was used immediately without purification or characterisation.

**5.1.8. (2R,3R)-3'-Benzyloxy-4'',6''-dibenzyloxyflavan (16).** Crude bromo formate **15** (750 mg, 1.1 mmol) was treated with K<sub>2</sub>CO<sub>3</sub> (170 mg, 1.1 mmol) in acetone (10 mL) and stirred at rt over 5 h. The mixture was diluted with H<sub>2</sub>O (5.0 mL), extracted into EtOAc (3 × 10 mL), the combined organics dried with (MgSO<sub>4</sub>), filtered and concentrated to dryness. The resulting compound was then redissolved in MeOH (10 mL), treated with K<sub>2</sub>CO<sub>3</sub> (170 mg, 1.1 mmol) and the mixture stirred at rt overnight. The mixture was then concentrated in vacuo, extracted into EtOAc (3 × 15 mL), the combined organics dried (MgSO<sub>4</sub>), filtered, concentrated to dryness and the product purified by flash chromatography (Silica, 50% Et<sub>2</sub>O/hexanes) to give **16** as a colourless oil (310 mg, 61%); IR  $\nu_{\max}$  3439, 3031, 2924, 1619, 1592 cm<sup>-1</sup>; <sup>1</sup>H NMR (500 MHz, CDCl<sub>3</sub>)  $\delta$  3.06 (dd, 1H, *J* = 17, 4.4 Hz, ArCH<sub>2</sub>CHCHO), 3.11 (dd, 1H, *J* = 9.8, 2.1 Hz, ArCH<sub>2</sub>CHCHO), 4.39 (br s, 1H, ArCH<sub>2</sub>CHCHO), 5.10–5.15 (m, 5H, ArCH<sub>2</sub>CHCHO, and 2 × OCH<sub>2</sub>Ph), 5.19 (s, 2H, OCH<sub>2</sub>Ph), 6.38 (d, 1H, *J* = 2.3 Hz, ArH), 6.40 (d, 1H, *J* = 2.3 Hz, ArH), 7.06 (dd, 1H, *J* = 8.2, 2.5 Hz, ArH), 7.18 (dd, 1H, *J* = 8.2, 0.6 Hz, ArH), 7.29 (s, 1H, ArH), 7.41–7.56 (m, 16H, ArH); <sup>13</sup>C NMR (100 MHz, CDCl<sub>3</sub>)  $\delta$  28.3, 66.5, 69.9, 70.1, 70.2, 78.6, 94.2, 94.7, 101.0, 113.0, 114.4, 118.8, 127.2, 127.3, 127.7, 128.0, 128.1, 128.6, 128.7, 129.8, 136.9, 137.1, 139.9, 155.2, 158.4, 158.8, 159.1; MS (ES, *m/z*) 567 (M<sup>+</sup> + Na, 20%), 545 (MH<sup>+</sup>, 100%); HRMS (ES, *m/z*) found 567.2111, C<sub>36</sub>H<sub>32</sub>O<sub>5</sub>Na requires 567.2147; [ $\alpha$ ]<sub>D</sub> –25.7 (*c* 3.4, CH<sub>2</sub>Cl<sub>2</sub>, at 23 °C).

**5.1.9. (–)-3-Hydroxy B-ring modified (–)-ECg (2).** To a solution of tri-*O*-benzyl gallic acid (54 mg, 0.12 mmol) in CH<sub>2</sub>Cl<sub>2</sub> (5.0 mL) was added DCC (25 mg, 0.12 mmol) and the mixture was stirred at rt for 5 min. Alcohol **16** (42 mg, 0.081 mmol) was then added in CH<sub>2</sub>Cl<sub>2</sub> (5.0 mL) followed by DMAP (5.0 mg) and the mixture was stirred at rt overnight. The mixture was then filtered, concentrated in vacuo and purified by flash chromatography (Silica, 10% Et<sub>2</sub>O/hexanes) to yield the globally protected gallate ester as a colourless oil (49 mg, 64%); IR  $\nu_{\max}$  2923, 2851, 1707, 1590 cm<sup>-1</sup>; <sup>1</sup>H NMR (400 MHz, CDCl<sub>3</sub>)  $\delta$  3.19 (d, 2H, *J* = 3.4 Hz, ArCH<sub>2</sub>CHCHO), 4.82 (d, 1H, *J* = 11 Hz, OCH<sub>2</sub>Ph), 4.91 (d, 1H, *J* = 11 Hz, OCH<sub>2</sub>Ph), 5.08–5.10 (m, 11H, ArCH<sub>2</sub>CHCHO, and 5 × OCH<sub>2</sub>Ph), 5.70–5.71 (m, 1H, ArCH<sub>2</sub>CHCHO), 6.39 (d, 1H, *J* = 2.3 Hz, ArH), 6.47 (d, 1H, *J* = 2.3 Hz, ArH), 6.93 (dd, 1H, *J* = 7.9, 2.2 Hz, ArH), 7.06 (d, 1H, *J* = 7.9 Hz, ArH), 7.20–7.21 (m, 1H, ArH), 7.33–7.52 (m, 33H, ArH); <sup>13</sup>C NMR (100 MHz, CDCl<sub>3</sub>)  $\delta$  26.5, 69.2, 70.4, 70.6, 71.4, 71.9, 75.0, 78.1, 94.4, 95.2, 101.4, 109.5, 110.6, 113.7, 114.9, 119.6, 127.7, 128.0, 128.1, 128.2, 128.4, 128.5, 128.6, 128.7, 129.0, 129.1, 129.9, 137.0, 137.3, 137.9, 139.9, 142.9, 152.8, 156.0, 158.5, 159.3, 165.6; MS (ES, *m/z*) 967 (M<sup>+</sup>, 5%), 647 (MH<sup>+</sup> – 318, 100%); HRMS (ES, *m/z*) found 967.3859, C<sub>64</sub>H<sub>55</sub>O<sub>9</sub> requires 967.3846; [ $\alpha$ ]<sub>D</sub> –31.4 (*c* 3.3, CH<sub>2</sub>Cl<sub>2</sub>, at 23 °C).

A solution of the globally protected gallate ester (170 mg, 0.18 mmol) and 10% Pd (OH)<sub>2</sub> (10 mg) in EtOAc (10 mL)

was stirred under an atmosphere of H<sub>2</sub> (balloon) for 12 h. The mixture was then filtered through celite, concentrated in vacuo and purified by flash chromatography (Silica, Et<sub>2</sub>O) to yield the product (–)-**2** (72 mg, 94%) as an off-white solid; mp >200 °C; IR  $\nu_{\max}$  3329 (br), 2950, 1607 cm<sup>-1</sup>; <sup>1</sup>H NMR (500 MHz, (CD<sub>3</sub>)<sub>2</sub>CO)  $\delta$  2.99 (dd, 1H, *J* = 18, 2.0 Hz, ArCH<sub>2</sub>CHCHO), 3.12 (dd, 1H, *J* = 18, 4.6 Hz, ArCH<sub>2</sub>CHCHO), 3.15 (br s, 1H, OH), 5.27 (s, 1H, ArCH<sub>2</sub>CHCHO), 5.64–5.66 (m, 1H, ArCH<sub>2</sub>CHCHO), 6.11 (d, 1H, *J* = 2.3 Hz, ArH), 6.12 (d, 1H, *J* = 2.3 Hz, ArH), 6.77 (ddd, 1H, *J* = 8.0, 2.5, 0.9 Hz, ArH), 7.07–7.20 (m, 5H, ArH), 8.36 (br s, 5H, OH); <sup>13</sup>C NMR (125 MHz, (CD<sub>3</sub>)<sub>2</sub>O)  $\delta$  13.5, 68.4, 77.2, 94.9, 95.7, 98.0, 109.0, 113.9, 114.6, 117.7, 120.8, 129.0, 138.0, 140.4, 145.1, 156.0, 156.6, 157.0, 157.2, 165.1; MS (ES, *m/z*) 449 (M<sup>+</sup> + Na, 65%), 257 (M<sup>+</sup> – 151, 100%); HRMS (ES, *m/z*) found 449.0818, C<sub>22</sub>H<sub>18</sub>O<sub>9</sub>Na requires 449.0846; [ $\alpha$ ]<sub>D</sub> –130.8 (*c* 0.3, (CH<sub>3</sub>)<sub>2</sub>CO, at 23 °C).

**5.1.10. 3',4,5',6-Tetrabenzoyloxy-2-O-methoxymethyl-E-retro-chalcone (18).** Acetophenone **17** (3.3 g, 13 mmol) and benzaldehyde **8** (4.2 g, 11 mmol) were condensed in an identical manner to the preparation of **10** to give **18** (6.5 g, 94%), as a fine yellow powder; mp 108–110 °C; IR  $\nu_{\max}$  2933, 2872, 1650, 1585, 1568, 1454 cm<sup>-1</sup>; <sup>1</sup>H NMR (400 MHz, CDCl<sub>3</sub>)  $\delta$  3.59 (s, 3H, OCH<sub>2</sub>OCH<sub>3</sub>), 5.09 (s, 4H, 2 × OCH<sub>2</sub>Ph), 5.16 (s, 2H, OCH<sub>2</sub>Ph), 5.20 (s, 2H, OCH<sub>2</sub>Ph), 5.34 (s, 2H, OCH<sub>2</sub>OCH<sub>3</sub>), 6.28 (d, 1H, *J* = 2.2 Hz, ArH), 6.60 (d, 1H, *J* = 2.2 Hz, ArH), 6.84, (t, 1H, *J* = 2.3 Hz, ArH), 7.23 (t, 1H, *J* = 2.3 Hz, ArH), 7.35–7.53 (m, 21H, ArH), 7.94 (d, 1H, *J* = 16 Hz, ArCH<sub>2</sub>CH=CHCO), 8.41 (d, 1H, *J* = 16 Hz, ArCH<sub>2</sub>CH=CHCO); <sup>13</sup>C NMR (125 MHz, CDCl<sub>3</sub>)  $\delta$  56.1, 70.1, 70.3, 70.9, 94.4, 94.5, 94.7, 95.0, 106.9, 107.4, 107.7, 122.3, 126.7, 127.3, 127.5, 127.6, 127.7, 127.8, 128.1, 128.3, 128.7, 128.9, 136.1, 139.7, 159.5, 159.6, 160.7, 162.1, 191.4; MS (ES, *m/z*) 693 (MH<sup>+</sup>, 20%); HRMS (ES, *m/z*) found 693.2817, C<sub>45</sub>H<sub>41</sub>O<sub>7</sub> requires 693.2852.

**5.1.11. 1-(3',5'-Dibenzyloxyphenyl)-3-(2''-O-methoxymethyl-4'',6''-dibenzyloxyphenyl)propan-1-ol (19).** In an identical manner to the preparation of **11** chalcone **18** (5.9 g, 9.5 mmol) was converted into crude ketone (4.7 g, 86%) and then alcohol **19** (4.7 g, 99%) as a pale yellow solid; mp 119–120 °C; IR  $\nu_{\max}$  3575, 2946, 1594, 1497, 1453 cm<sup>-1</sup>; <sup>1</sup>H NMR (400 MHz, CDCl<sub>3</sub>)  $\delta$  1.99 (m, 2H, ArCH<sub>2</sub>CH<sub>2</sub>CHOH), 2.87 (m, 3H, ArCH<sub>2</sub>CH<sub>2</sub>CHOH and OH), 3.50 (s, 3H, OCH<sub>2</sub>OCH<sub>3</sub>), 4.53 (m, 1H, CHOH), 5.02 (s, 4H, 2 × OCH<sub>2</sub>Ph), 5.05 (s, 2H, OCH<sub>2</sub>Ph), 5.07 (s, 2H, OCH<sub>2</sub>Ph), 5.21 (s, 2H, OCH<sub>2</sub>OCH<sub>3</sub>), 6.37 (s, 1H, ArH), 6.57 (s, 2H, ArH), 6.68 (s, 2H, ArH), 7.24–7.47 (m, 20H, ArH); <sup>13</sup>C NMR (100 MHz, CDCl<sub>3</sub>)  $\delta$  0.7, 39.2, 56.6, 70.5, 70.8, 73.5, 94.8, 95.0, 95.3, 101.1, 105.4, 112.0, 127.6, 128.0, 128.1, 128.3, 128.4, 128.5, 129.0, 129.1, 137.3, 147.8, 156.158.3, 160.3; MS (ES, *m/z*) 719 (M<sup>+</sup> + Na, 30%), 239 (M<sup>+</sup> – 480, 100%); HRMS (ES, *m/z*) found 719.2916, C<sub>45</sub>H<sub>44</sub>O<sub>7</sub>Na requires 719.2985.

**5.1.12. (E)-1-(3',5'-Dibenzyloxyphenyl)-3-(2''-O-methoxymethyl-4'',6''-dibenzyloxyphenyl)propene (20).** In an identical manner to the preparation of **12**, alcohol **19** (2.5 g, 4.0 mmol) gave the corresponding bromide (2.8 g, 99%) as a white solid; mp 114–115 °C; IR  $\nu_{\max}$  3062, 2932,

1595, 1497, 1453  $\text{cm}^{-1}$ ;  $^1\text{H}$  NMR (400 MHz,  $\text{CDCl}_3$ )  $\delta$  2.51 (m, 2H,  $\text{ArCH}_2\text{CH}_2\text{CHBr}$ ), 2.78 (m, 1H,  $\text{ArCH}_2\text{CH}_2\text{CHBr}$ ), 2.93 (m, 1H,  $\text{ArCH}_2\text{CH}_2\text{CHBr}$ ), 3.52 (s, 3H,  $\text{OCH}_2\text{OCH}_3$ ), 5.06 (m, 9H,  $4 \times \text{OCH}_2\text{Ph} + \text{CHBr}$ ), 5.21 (s, 2H,  $\text{OCH}_2\text{OCH}_3$ ), 6.36 (d, 1H,  $J=2.2$  Hz, *ArH*), 5.85 (d, 1H,  $J=2.2$  Hz, *ArH*), 6.59 (t, 1H,  $J=2.2$  Hz, *ArH*), 6.75 (d, 2H,  $J=2.2$  Hz, *ArH*), 7.33–7.53 (m, 20H, *ArH*);  $^{13}\text{C}$  NMR (100 MHz,  $\text{CDCl}_3$ )  $\delta$  22.5, 39.7, 56.1, 56.6, 70.6, 94.7, 94.9, 95.2, 102.1, 107.2, 111.8, 127.4, 127.7, 128.0, 128.1, 128.2, 128.4, 128.5, 129.0, 137.2, 137.6, 145.0, 157.0, 158.3, 159.0, 160.4; MS (ES,  $m/z$ ) 760 ( $\text{M}^+$ , 10%), 723 ( $\text{M}^+ - 37$ , 100%); HRMS (ES,  $m/z$ ) found 760.2229,  $\text{C}_{45}\text{H}_{44}\text{O}_6\text{Br}$  requires 760.2222.

The bromide (2.8 g, 4.0 mmol) gave styrene **20** (1.3 g, 53%) as a white solid; mp 103–104 °C; IR  $\nu_{\text{max}}$  3087, 2932, 1676, 1593, 1497, 1453  $\text{cm}^{-1}$ ;  $^1\text{H}$  NMR (400 MHz,  $\text{CDCl}_3$ )  $\delta$  3.53 (s, 3H,  $\text{OCH}_2\text{OCH}_3$ ), 3.65–3.66 (m, 2H,  $\text{CH}_2\text{CH}=\text{CH}$ ), 5.09 (s, 4H,  $2 \times \text{OCH}_2\text{Ph}$ ), 5.11 (s, 2H,  $\text{OCH}_2\text{Ph}$ ), 5.14 (s, 2H,  $\text{OCH}_2\text{Ph}$ ), 5.25 (s, 2H,  $\text{OCH}_2\text{OCH}_3$ ), 6.37–6.38 (m, 2H,  $\text{ArCH}_2\text{CH}=\text{CH}$ ), 6.42 (d, 1H,  $J=2.2$  Hz, *ArH*), 6.54 (t, 1H,  $J=2.2$  Hz, *ArH*), 6.57 (d, 1H,  $J=2.2$  Hz, *ArH*), 6.64 (s, 1H, *ArH*), 6.65 (s, 1H, *ArH*), 7.34–7.56 (m, 20H, *ArH*);  $^{13}\text{C}$  NMR (100 MHz,  $\text{CDCl}_3$ )  $\delta$  27.0, 56.6, 70.4, 70.5, 70.6, 70.7, 94.7, 95.0, 95.1, 101.1, 105.8, 108.3, 110.9, 127.6, 127.7, 128.0, 128.1, 128.3, 128.4, 128.5, 129.0, 129.1, 129.9, 130.5, 137.3, 137.4, 137.5, 137.7, 140.7, 156.9, 158.4, 159.1, 160.5; MS (ES,  $m/z$ ) 679 ( $\text{MH}^+$ , 10%), 576 ( $\text{M}^+ - 103$ , 100%); HRMS (ES,  $m/z$ ) found 679.3167  $\text{C}_{45}\text{H}_{43}\text{O}_6$  requires 679.3060.

**5.1.13. (1*R*,2*R*)-1-(3',5'-Dibenzoyloxyphenyl)-3-(2''-O-methoxymethyl-4'',6''-dibenzoyloxyphenyl)propane-1,2-diol (21).** In an identical manner to the preparation of **13** styrene **20** (1.4 g, 2.3 mmol) gave **21** as a white solid (1.2 g, 82%, 75% *ee* by HPLC<sup>15</sup>) that was then recrystallised (80%  $\text{Et}_2\text{O}/\text{EtOAc}$ ) to give enantiomerically pure **21** (670 mg, 46%); mp 84–86 °C; IR  $\nu_{\text{max}}$  3520, 2928, 1594, 1151  $\text{cm}^{-1}$ ;  $^1\text{H}$  NMR (500 MHz,  $\text{CDCl}_3$ )  $\delta$  2.99–3.10 (m, 2H,  $\text{ArCH}_2\text{CH}(\text{OH})\text{CH}(\text{OH})$ ), 3.55 (s, 3H,  $\text{OCH}_2\text{OCH}_3$ ), 4.06–4.09 (m, 1H,  $\text{ArCH}_2\text{CH}(\text{OH})\text{CH}(\text{OH})$ ), 4.60 (d, 1H,  $J=4.5$  Hz,  $\text{ArCH}_2\text{CH}(\text{OH})\text{CH}(\text{OH})$ ), 5.11 (s, 4H,  $2 \times \text{OCH}_2\text{Ph}$ ), 5.13 (s, 2H,  $\text{OCH}_2\text{Ph}$ ), 5.14 (s, 2H,  $\text{OCH}_2\text{Ph}$ ), 5.25 (dd, 2H,  $J=13$ , 6.7 Hz,  $\text{OCH}_2\text{OCH}_3$ ), 6.47 (d, 1H,  $J=2.2$  Hz, *ArH*), 6.58 (d, 1H,  $J=2.2$  Hz, *ArH*), 7.00 (t, 1H,  $J=2.1$  Hz, *ArH*), 7.05 (s, 1H, *ArH*), 7.12 (s, 1H, *ArH*), 7.40–7.53 (m, 20H, *ArH*);  $^{13}\text{C}$  NMR (100 MHz,  $\text{CDCl}_3$ )  $\delta$  27.6, 56.4, 70.1, 70.3, 70.6, 75.7, 76.2, 94.5, 94.7, 94.9, 101.2, 105.9, 108.3, 127.3, 127.8, 128.1, 128.2, 128.7, 128.9, 136.6, 136.8, 137.0, 143.9, 156.9, 158.1, 159.0, 160.0; MS (ES,  $m/z$ ) 735 ( $\text{MH}^+$ , 80%), 363 ( $\text{M}^+ - 372$ , 100%); HRMS (ES,  $m/z$ ) found 735.2970,  $\text{C}_{45}\text{H}_{45}\text{O}_8$  requires 735.2958;  $[\alpha]_{\text{D}} + 3.0$  (*c* 0.1,  $\text{CH}_2\text{Cl}_2$ , at 24 °C).

**5.1.14. (1*R*,2*R*)-1-(3',5'-Dibenzoyloxyphenyl)-3-(2''-hydroxy-4'',6''-dibenzoyloxyphenyl)propane-1,2-diol (22).** In an identical manner to the preparation of **14** diol **21** (670 mg, 1.0 mmol) gave triol **22** as a white solid (600 mg, 100%); mp 91–92 °C; IR  $\nu_{\text{max}}$  3384, 3031, 2910, 1595, 1150  $\text{cm}^{-1}$ ;  $^1\text{H}$  NMR (400 MHz,  $\text{CDCl}_3$ )  $\delta$  2.86 (dd, 1H,  $J=15$ , 12 Hz,  $\text{ArCH}_2\text{CH}(\text{OH})\text{CH}(\text{OH})$ ), 3.01 (dd, 1H,  $J=15$ , 3.7 Hz,  $\text{ArCH}_2\text{CH}(\text{OH})\text{CH}(\text{OH})$ ), 4.02–4.05 (m, 1H,  $\text{ArCH}_2\text{CH}(\text{OH})\text{CH}(\text{OH})$ ), 4.50 (d, 1H,  $J=5.9$  Hz,

$\text{ArCH}_2\text{CH}(\text{OH})\text{CH}(\text{OH})$ ), 4.89–5.00 (m, 8H,  $4 \times \text{OCH}_2\text{Ph}$ ), 6.26 (d, 1H,  $J=2.3$  Hz, *ArH*), 6.31 (d, 1H,  $J=2.3$  Hz, *ArH*), 6.56 (t, 1H,  $J=2.1$  Hz, *ArH*), 6.63 (s, 1H, *ArH*), 6.64 (s, 1H, *ArH*), 7.18–7.48 (m, 20H, *ArH*);  $^{13}\text{C}$  NMR (100 MHz,  $\text{CDCl}_3$ )  $\delta$  27.2, 70.4, 70.5, 77.1, 94.0, 96.3, 102.3, 106.4, 106.7, 127.1, 128.0, 128.1, 128.4, 128.5, 128.9, 129.0, 129.1, 137.2, 137.4, 143.5, 157.6, 158.3, 159.5, 160.4; MS (ES,  $m/z$ ) 669 ( $\text{MH}^+$ , 100%); HRMS (ES,  $m/z$ ) found 669.2855,  $\text{C}_{43}\text{H}_{41}\text{O}_7$  requires 669.2852;  $[\alpha]_{\text{D}} - 7.5$  (*c* 4.2,  $\text{CH}_2\text{Cl}_2$ , at 24 °C).

**5.1.15. (1*S*,2*R*)-1-Bromo-2-formate (23).** In an identical manner to the preparation of **15** triol **22** (550 mg, 0.93 mmol) gave bromo formate **23** as a brown foam (580 mg, 91%). This compound was used immediately without purification or characterisation.

**5.1.16. (2*R*,3*R*)-3',5'-Dibenzoyloxy-4'',6''-dibenzoyloxyflavan (24).** In an identical manner to the preparation of **16** crude bromo formate **23** (580 mg, 0.90 mmol) gave **24** as a colourless oil (222 mg, 45%); IR  $\nu_{\text{max}}$  3562, 3064, 3032, 2925, 1593, 1150  $\text{cm}^{-1}$ ;  $^1\text{H}$  NMR (400 MHz,  $\text{CDCl}_3$ )  $\delta$  1.65 (d, 1H,  $J=5.2$  Hz, *OH*), 2.87 (dd, 1H,  $J=18$ , 4.4 Hz,  $\text{ArCH}_2\text{CHCHO}$ ), 2.97 (dd, 1H,  $J=18$ , 2.0 Hz,  $\text{ArCH}_2\text{CHCHO}$ ), 4.19–4.23 (m, 1H,  $\text{ArCH}_2\text{CHCHO}$ ), 4.86 (s, 1H,  $\text{ArCH}_2\text{CHCHO}$ ), 4.88–5.02 (m, 8H,  $4 \times \text{OCH}_2\text{Ph}$ ), 6.21 (d, 1H,  $J=2.4$  Hz, *ArH*), 6.23 (d, 1H,  $J=2.4$  Hz, *ArH*), 6.53 (t, 1H,  $J=2.4$  Hz, *ArH*), 6.70 (s, 1H, *ArH*), 6.71 (s, 1H, *ArH*), 7.21–7.30 (m, 20H, *ArH*);  $^{13}\text{C}$  NMR (100 MHz,  $\text{CDCl}_3$ )  $\delta$  28.2, 66.5, 70.0, 70.2, 77.2, 78.6, 94.1, 94.7, 101.0, 101.6, 105.4, 127.2, 127.6, 127.9, 128.1, 128.5, 128.6, 136.7, 136.9, 137.0, 140.7, 155.1, 158.3, 158.8, 160.2; MS (ES,  $m/z$ ) 651 ( $\text{MH}^+$ , 80%), 225 ( $\text{M} - 426$ , 100%); HRMS (ES,  $m/z$ ) found 651.2741,  $\text{C}_{43}\text{H}_{39}\text{O}_6$  requires 651.2747;  $[\alpha]_{\text{D}} - 17.2$  (*c* 0.8,  $\text{CH}_2\text{Cl}_2$ , at 24 °C).

**5.1.17. (–)-3,5-Dihydroxy B-ring modified (–)-ECg (3).** In an identical manner to the preparation of **2**, alcohol **24** (100 mg, 0.17 mmol) was converted to the globally protected gallate ester (120 mg, 67%); IR  $\nu_{\text{max}}$  3063, 3031, 1714, 1593  $\text{cm}^{-1}$ ;  $^1\text{H}$  NMR (400 MHz,  $\text{CDCl}_3$ )  $\delta$  3.03 (d, 2H,  $J=3.2$  Hz,  $\text{ArCH}_2\text{CHCHO}$ ), 4.65 (d, 1H,  $J=12$  Hz,  $\text{OCH}_2\text{Ph}$ ), 4.73 (d, 1H,  $J=12$  Hz,  $\text{OCH}_2\text{Ph}$ ), 4.86–5.10 (m, 13H,  $\text{ArCH}_2\text{CHCHO}$ , and  $6 \times \text{OCH}_2\text{Ph}$ ), 5.56–5.57 (m, 1H,  $\text{ArCH}_2\text{CHCHO}$ ), 6.23 (d, 1H,  $J=2.4$  Hz, *ArH*), 6.31 (d, 1H,  $J=2.4$  Hz, *ArH*), 6.42 (t, 1H,  $J=2.0$  Hz, *ArH*), 6.64 (s, 1H, *ArH*), 6.65 (s, 1H, *ArH*), 7.13–7.24 (m, 37H, *ArH*);  $^{13}\text{C}$  NMR (100 MHz,  $\text{CDCl}_3$ )  $\delta$  26.5, 68.7, 70.0, 70.1, 70.2, 71.0, 75.1, 77.9, 94.0, 94.8, 101.0, 101.2, 106.0, 109.1, 125.1, 127.3, 127.5, 127.6, 127.7, 127.8, 127.9, 128.0, 128.2, 128.4, 128.6, 136.6, 136.7, 136.9, 137.5, 138.1, 142.6, 152.4, 155.6, 158.0, 158.9, 160.0, 165.1;  $[\alpha]_{\text{D}} - 43.8$  (*c* 2.4,  $\text{CH}_2\text{Cl}_2$ , at 24 °C).

A solution of the globally protected gallate ester (120 mg, 0.11 mmol) was hydrogenolysed to give (–)-**3** (18 mg, 37%) as an off-white solid; mp > 200 °C; IR  $\nu_{\text{max}}$  3332, 1608, 1237  $\text{cm}^{-1}$ ;  $^1\text{H}$  NMR (400 MHz,  $(\text{CD}_3)_2\text{CO}$ )  $\delta$  2.76–2.95 (m, 2H,  $\text{ArCH}_2\text{CHCHO}$ ), 4.99 (s, 1H,  $\text{ArCH}_2\text{CHCHO}$ ), 5.46–5.48 (m, 1H,  $\text{ArCH}_2\text{CHCHO}$ ), 5.91–5.93 (m, 2H, *ArH*), 6.11 (t, 1H,  $J=2.4$  Hz, *ArH*), 6.43–6.44 (m, 2H, *ArH*), 6.88 (s, 2H, *ArH*), 8.01 (br s, 7H, *OH*);  $^{13}\text{C}$  NMR (100 MHz,  $(\text{CD}_3)_2\text{O}$ )  $\delta$  20.7, 26.6, 60.8, 66.6, 69.2, 78.1,

95.8, 96.6, 99.1, 102.8, 106.0, 110.0, 121.8, 138.8, 139.0, 141.0, 146.0, 156.9, 157.5, 157.8, 159.2, 166.1; MS (ES,  $m/z$ ) 443 ( $MH^+$ , 80%), 273 ( $M^+ - 169$ , 100%); HRMS (ES,  $m/z$ ) found 443.1017,  $C_{22}H_{19}O_{10}$  requires 443.0978;  $[\alpha]_D -55.0$  ( $c$  2.5,  $(CH_3)_2O$ , at 24 °C).

**5.2. Microbiological evaluation of 2 and 3.** *S. aureus* BB 568 was provided by Professor B. Berger-Bächi, University of Zürich, Switzerland. EMRSA-15 and EMRSA-16 were clinical isolates obtained from the Royal Free Hospital London. The capacity of the various compounds to modulate  $\beta$ -lactam resistance was evaluated by determination of the MIC at a fixed concentration in combination with oxacillin. Assays were performed in 96-well microtiter trays with a bacterial inoculum of about  $10^4$  colony-forming units in 100  $\mu$ l of Mueller-Hinton broth (Oxoid, Basingstoke, UK) supplemented with 2% w/v NaCl. Doubling dilutions of oxacillin were employed. MIC values were recorded after incubation of the trays at 35 °C for 24 h. *S. aureus* ATCC 29213 was used as the standard. The intrinsic anti-staphylococcal activity of compounds was also evaluated using these methods.

#### Acknowledgements

This work was supported by MRC Strategic Grant G0000996. We thank S. Shah for undertaking the antibacterial assays, Mr. T. Hollingworth and Mr. D. Hooper for providing mass spectra and Mr. T. J. Spencer for micro analytical data.

#### References and notes

- (a) Salah, N.; Miller, N. J.; Paganga, G.; Tijburg, L.; Bolwell, G. P.; Rice-Evans, C. *Arch. Biochem. Biophys.* **1995**, *322*, 339. (b) Suganuma, M.; Okabe, S.; Oniyama, M.; Tada, Y.; Ito, H.; Fujiki, H. *Carcinogenesis* **1998**, *19*, 1771. (c) Ahmad, N.; Mukhta, H. *Nutr. Rev.* **1999**, *57*, 78. (d) Matsuo, N.; Yamada, K.; Shoji, K.; Mori, M.; Sugano, M. *Allergy* **1997**, *52*, 58. (e) Miura, S.; Watanabe, J.; Sano, M.; Tomita, T.; Osawa, T.; Hara, Y.; Tomita, I. *Biol. Pharm. Bull.* **1995**, *18*, 1.
- (a) Chu, D. C. In *Chemistry and Applications of Green Tea*; Yamamoto, T., Juneja, L. R., Chu, D. C., Kim, M., Eds.; CRC: Boca Raton, FL, 1997; pp 1–11. (b) Chu, D. C.; Juneja, L. R. In *Chemistry and Applications of Green Tea*; Yamamoto, T., Juneja, L. R., Chu, D. C., Kim, M., Eds.; CRC: Boca Raton, FL, 1997; pp 13–32.
- (a) Yang, C. S.; Wang, Z. Y. *J. Natl. Cancer Res.* **1993**, *85*, 1038. (b) Kato, I.; Tominaga, S.; Matsuura, A.; Yoshii, Y.; Shirai, M.; Kobayashi, S. A. *Jpn. J. Cancer Res.* **1990**, *81*, 1101. (c) Zheng, W.; Doyle, T. J.; Hong, C. P.; Kushi, L. H.; Sellers, T. A.; Folsom, A. R. *Proc. Am. Assoc. Cancer Res.* **1995**, *36*, 278. (d) Yang, C. S.; Chen, L.; Lee, M. J.; Landau, J. M. *Adv. Exp. Med. Biol.* **1996**, *401*, 971. (e) Fujiki, H.; Suganuma, M.; Okabe, S.; Komori, A.; Sueoka, E.; Sueoka, N.; Kozu, T.; Sakai, Y. *Nutr. Rev.* **1996**, *54*, S67. (f) Imai, K.; Suga, K.; Nakachi, K. *Prev. Med.* **1997**, *26*, 769. (g) Nakachi, K.; Suemasu, K.; Suga, K.; Takeo, T.; Imai, K.; Higashi, Y. *Jpn. J. Cancer Res.* **1998**, *89*, 254.
- (a) Amarowicz, R.; Pegg, R. B.; Bautista, D. A. *Nahrung* **2000**, *44*, 60. (b) Yee, Y.-K.; Koo, M. W.-L. *Aliment. Pharmacol. Ther.* **2000**, *14*, 635. (c) Sakanaka, S.; Kim, M.; Taniguchi, M.; Yamamoto, T. *Agric. Biol. Chem.* **1989**, *53*, 2307. (d) Mabe, K.; Yamada, M.; Oguni, I.; Takahashi, T. *Antimicrob. Agents Chemother.* **1999**, *43*, 1788.
- (a) Hamiltom-Miller, J. M. T.; Shah, S. J. *Antimicrob. Chemother.* **2000**, *46*, 847. (b) Shiota, S.; Shimizu, M.; Mizushima, T.; Ito, H.; Hitano, T.; Yoshida, T.; Tsuchiya, T. *Biol. Pharm. Bull.* **1999**, *22*, 1388. (c) Stapleton, P. D.; Taylor, P. W. *Sci. Progr.* **2002**, *85*, 57.
- Firth, N. In *Multiple Drug Resistant Bacteria*; Ambile-Cuevas, C. F., Ed.; Horizon Scientific: Wymondham, 2003; pp 33–60.
- Stapleton, P. D.; Shah, S.; Anderson, J. C.; Hara, Y.; Hamilton-Miller, J. M. T.; Taylor, P. W. *Int. J. Antimicrob. Agents* **2004**, *23*, 462.
- Kohri, T.; Matsumoto, N.; Yamakawa, M.; Suzuki, M.; Nanjo, F.; Hara, Y.; Oku, N. *J. Agric. Food Chem.* **2001**, *49*, 4102.
- (a) Freudenberg, K.; Böhme, O.; Purman, L. *Ber. Dtsch. Chem. Ges. B* **1922**, *55*, 1734. (b) Freudenberg, K.; Purman, L. *Justus Liebigs Ann. Chem.* **1924**, *437*, 274.
- Kiatgrajai, P.; Wellons, J. D.; Gollob, L.; White, J. D. *J. Org. Chem.* **1982**, *47*, 2910.
- Suzuki, M.; Sano, M.; Yoshida, R.; Degawa, M.; Miyase, T.; Maeda-Yamamoto, M. *J. Agric. Food Chem.* **2003**, *51*, 510.
- Anderson, J. C.; Headley, C.; Stapleton, P. D.; Taylor, P. W. *Bioorg. Med. Chem. Lett.* **2005**, *15*, 2633.
- Taylor, P. W.; Stapleton, P. D.; Shah, S.; Anderson, J. C. *ICOS Proc.* **2004**, *4*, 414–417.
- Hashimoto, T.; Kumazawa, S.; Nanjo, F.; Hara, Y.; Nakayama, T. *Biosci. Biotechnol. Biochem.* **1999**, *63*, 2252.
- Mehta, P. P.; Whalley, W. B. *J. Chem. Soc.* **1963**, 5327.
- Freudenberg, K. *Sci. Proc. Roy. Dublin Soc.* **1956**, *27*, 153.
- Li, L.; Chan, T. H. *Org. Lett.* **2001**, *3*, 739.
- Zaveri, N. T. *Org. Lett.* **2001**, *3*, 843.
- Kolb, H. C.; VanNieuwenhze, M. S.; Sharpless, K. B. *Chem. Rev.* **1994**, *94*, 2483.
- Tukmantel, W.; Kozikowski, A. P.; Romanczyk, L. J., Jr. *J. Am. Chem. Soc.* **1999**, *121*, 12073.
- Bass, R. J.; Banks, B. J.; Leeming, M. R. G.; Snarey, M. *J. Chem. Soc., Perkin Trans. 1* **1981**, 124.
- Van Rensburg, H.; Heerden, P. S.; Ferreria, D. *J. Chem. Soc., Perkin Trans. 1* **1997**, 3415.
- (a) LiAlH<sub>4</sub> see: Fukuzawa, S.; Fujinami, T.; Yamauchi, S.; Sakai, S. *J. Chem. Soc., Perkin Trans. 1* **1986**, 1929. (b) NaBH<sub>4</sub>, CoCl<sub>2</sub> see: Aramini, A.; Brinchi, L.; Germani, R.; Savelli, G. *Eur. J. Org. Chem.* **2000**, *9*, 1793.
- Evans, D. A.; Fu, G. C. *J. Org. Chem.* **1990**, *55*, 5678.
- Alexandre, C.; Rouessac, F. *Bull. Soc. Chim. Fr.* **1971**, 1837.
- Enantiomeric purity measured by HPLC analysis against a racemic sample on a Chiralcel AD column *i*-PrOH/hexane (60:40), 0.15 mL min<sup>-1</sup>, *R*<sub>t</sub> *R,R* (major) 20.3 min, *S,S* 24.7 min. Absolute configuration was assumed from the Sharpless mnemonic (see Ref. 19).
- Van Rensburg, H.; Heerden, P. S.; Bezuidenhoudt, B. C. B.; Ferreria, D. *Tetrahedron Lett.* **1997**, *17*, 3415.
- (a) Baganz, H.; Domaschke, L. *Chem. Ber.* **1958**, *91*, 653. (b) Kolb, H. C.; Sharpless, K. B. *Tetrahedron* **1992**, *48*, 10515.
- Tukmantel, W.; Kozikowski, A. P.; Romanczyk, L. J. *J. Am. Chem. Soc.* **1999**, *121*, 12073.
- Anderson, J. C.; Blake, A. J.; Graham, J. P.; Wilson, C. *Org. Biomol. Chem.* **2003**, *1*, 2877.

# Synthesis of ketene phenyl- and butyltelluroacetals by a Horner–Wittig route

Claudio C. Silveira,<sup>a,\*</sup> Rodrigo Cella,<sup>a</sup> Antonio L. Braga,<sup>a</sup> Raquel G. Jacob,<sup>a</sup> Eder J. Lenardão<sup>b</sup> and Gelson Perin<sup>b,\*</sup>

<sup>a</sup>Departamento de Química, Universidade Federal de Santa Maria, UFSM, C.P. 5001, 97105-900 Santa Maria, RS, Brazil

<sup>b</sup>Departamento de Química, Universidade Federal de Pelotas, UFPel, PO Box 354, 96010-900 Pelotas, RS, Brazil

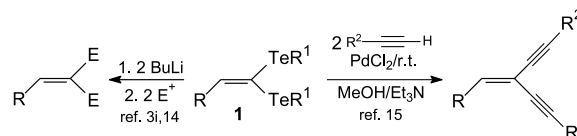
Received 31 March 2005; revised 25 May 2005; accepted 26 May 2005

Available online 17 June 2005

**Abstract**—New and efficient methods were developed to prepare ketene organytelluroacetals in moderate to excellent yields. This was accomplished by reaction of phenyl- or butyltelluromethylphosphonates with phenyl- or butyltellurenyl halides and aldehydes or cyclohexanone, under basic conditions. This Horner–Wittig protocol allows the preparation of several new tri- and tetra-substituted olefins. © 2005 Elsevier Ltd. All rights reserved.

## 1. Introduction

Vinyl tellurides have recently been recognized as important synthetic reagents and intermediates, because they are used in a variety of carbon–carbon bond forming reactions.<sup>1,2</sup> The most useful reaction of vinyl tellurides involves transmetalation by treatment with lithium,<sup>3</sup> Li/Ce,<sup>3a</sup> Li/Zn,<sup>4</sup> sodium,<sup>5</sup> copper,<sup>3g,6</sup> zinc,<sup>7</sup> and calcium organyls<sup>5</sup> as well as with Grignard reagents,<sup>3a,8</sup> followed by the capture of the resulting vinyl anion with electrophiles. An important characteristic of this metal/metalloid exchange is that, in the majority of these reactions, the geometry of the original double bond is retained.<sup>1</sup> More recently, very useful applications of vinyl tellurides have emerged as powerful tools for C–C bond construction: the homocoupling<sup>9</sup> of vinyl tellurides and their direct cross-coupling reactions with terminal alkynes,<sup>10</sup> Grignard reagents,<sup>11</sup> alkylzinc<sup>7a</sup> and alkylnylzinc derivatives.<sup>7b</sup> These are efficient protocols to prepare conjugated dienes, enynes and enediynes. The coupling can be catalyzed by palladium,<sup>7a,b,10,11</sup> Ni(II)<sup>10b,11</sup> or Co(II).<sup>11a,d</sup> Vinyl tellurides can also react with carbon monoxide in presence of Pd(II) salts to produce  $\alpha,\beta$ -unsaturated acids, esters and butenolides.<sup>12,13</sup> In this way, ketene organytelluroacetals **1**, are very useful both as vinyl 1,1-dianions<sup>3i,14</sup> or as vinyl 1,1-dicarbocation<sup>15</sup> equivalents



**Scheme 1.** High functionality of ketene organytelluroacetals **1**.

in Te/Metal exchanges and in cross-coupling reactions, respectively (Scheme 1).

When ketene organytelluroacetals **1** were submitted to Pd(II)-catalyzed cross-coupling with terminal alkynes,<sup>15</sup> only the butyltelluroacetals afforded the respective enediynes in good yields. This observation is related to a previous report<sup>3c</sup> indicating that vinylaryltellurides gave mixtures of vinyl- and aryllithiums by transmetalation with alkyllithiums.

In spite of the high synthetic potential of ketene organytelluroacetals, up to recent times these compounds were virtually unknown.<sup>16</sup>

To our knowledge, the only methods described for their preparation involve the hydrozirconation of acetylenic tellurides followed by transmetalation using a butyltellurenyl halide<sup>16a,b</sup> and the reaction of vinylcarbenes with diphenyl ditelluride (only two examples, in low yields).<sup>16c</sup> Moreover, the preparation of ketene telluroacetals with chain elongation is not possible by using these methods, which obviously limits their application in organic synthesis.

**Keywords:** Wittig reaction; Aldehydes; Ketene telluroacetals; Tellurium and compounds.

\* Corresponding authors. Tel./fax: +55 55 220 8754 (C.C.S.); tel./fax: +55 53 275 7354 (G.P.); e-mail addresses: silveira@quimica.ufsm.br; gelson\_perin@ufpel.edu.br

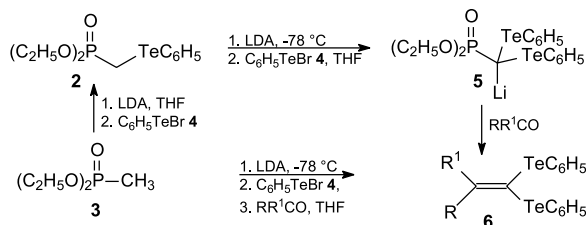
In the last years, our group has described practical and efficient methodologies for the preparation of vinyl chalcogenides based on Wittig and Horner–Wittig reactions,<sup>17,18</sup> including preliminary results on the synthesis of ketene phenyltelluroacetals by a Horner–Wittig methodology.<sup>16d</sup>

Due to our continuous interest on vinylic tellurium species, we describe here a full account on the synthesis of ketene phenyltelluroacetals and also a study of the synthesis of ketene butyltelluroacetals employing the same strategy.

## 2. Results and discussion

### 2.1. Preparation of ketene phenyltelluroacetals

Phenyltelluromethylphosphonate **2**, a reagent available on large scale and easily obtained in good yields by the reaction of diethyl methylphosphonate anion **3-Li** and phenyltellurenyl bromide **4**, was selected as starting material



**Scheme 2.** Synthesis of ketene phenyltelluroacetals.

(Scheme 2).<sup>19</sup> Treatment of **2** with LDA and phenyltellurenyl bromide **4** in THF, generated the lithiated species **5** which, upon reaction with aldehydes or cyclohexanone, afforded ketene phenyltelluroacetals **6a–g**, in a one-pot process (without isolation of intermediates), as depicted in Scheme 2. In most cases, good to excellent yields (72–94%) were obtained by using aromatic and aliphatic aldehydes (entries 1–5, Table 1). However, the reactions performed with acrolein and cyclohexanone gave the corresponding products in noticeably lower yields (entries 6 and 7, Table 1).

It was observed that the use of an excess of the phenyltelluromethylphosphonate **2** was required to afford **6a–g** in good yields. For example, reaction of 1.3 equiv of **2** with C<sub>6</sub>H<sub>5</sub>TeBr, followed by the addition of furfural, provided **6b** in 30% yield (entry 1, Table 2), while the yields increased to 64, 78 and 94% when 1.5, 1.7 and 2.0 equiv of **2**, were, respectively, employed (entries 2–4, Table 2). Therefore, and in view of the easy preparation of **2**, an excess (2 equiv) was used for the present study. Alternatively, compounds **6a–g** could be obtained directly from **3**, by reacting with LDA, phenyltellurenyl bromide **4** and then with the required carbonyl compound (Scheme 2). However, despite being an easier procedure, yield of **6b** was not satisfactory (entry 5, Table 2).

A very interesting feature was the fact that the corresponding vinyl telluride, a possible by-product resulting from the direct reaction of the anion derived from **2** with aldehydes, was not formed under the employed conditions (reactions at room temperature). It has been described that sodium salts

**Table 1.** Preparation of ketene bis(phenyltelluro) acetals **6** employing the strategy of Scheme 2

Entry	R	R <sup>1</sup>	Product <b>6</b>	Reaction time (h) <sup>a</sup>	Yields (%) <sup>b</sup>
1 <sup>c</sup>	C <sub>6</sub> H <sub>5</sub>	H		1	88
2	2-Furyl	H		1	94
3 <sup>d</sup>	4-NO <sub>2</sub> C <sub>6</sub> H <sub>4</sub>	H		1	72
4	CH <sub>3</sub> CH <sub>2</sub> CH <sub>2</sub>	H		2	94
5	(CH <sub>3</sub> ) <sub>2</sub> CH	H		2	84
6	CH <sub>2</sub> CH	H		2	41
7	–CH <sub>2</sub> (CH <sub>2</sub> ) <sub>3</sub> CH <sub>2</sub> –	H		2	16

<sup>a</sup> At room temperature.

<sup>b</sup> Isolated yields by column chromatography.

<sup>c</sup> Mp 67.9–69.2 °C (hexane).

<sup>d</sup> Mp 81.9–82.9 °C (hexane).



**Table 2.** Reaction of **2** or **3** with furfural to afford **6b**

Entry	Molar equivalents				Yield (%)
	<b>2</b>	<b>3</b>	LDA	C <sub>6</sub> H <sub>5</sub> TeBr	
1	1.3	—	2.4	1	30
2	1.5	—	2.6	1	64
3	1.7	—	2.8	1	78
4	2.0	—	3.1	1	94
5	—	1	3.1	2	45

of tellurophosphonates **2** required reflux in THF to react with aromatic aldehydes.<sup>19</sup> As a result of the more effective stabilizing capability of two C<sub>6</sub>H<sub>5</sub>Te groups the lithium intermediate **5** reacts with aromatic and aliphatic aldehydes and cyclohexanone at room temperature to give the desired products **6a–g**.

## 2.2. Preparation of ketene butyltelluroacetals

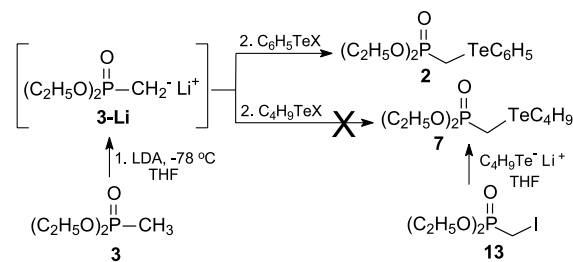
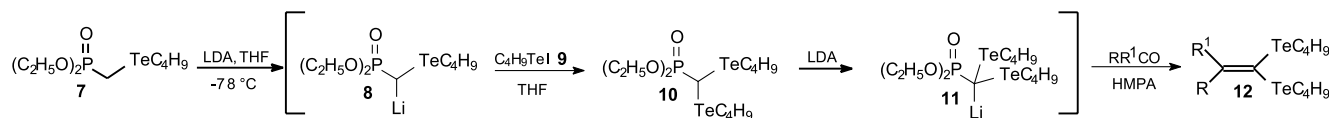
In view of the known cleaner Metal/Te exchange and cross-coupling reactions of vinyl butyltellurides as compared with their phenyltelluride analogs,<sup>3e,15</sup> we decided to perform a study on the preparation of ketene butyltelluroacetals by our Horner–Wittig route. In this way, treatment of butyltelluro-methylphosphonate<sup>19</sup> **7** with LDA generated the lithiated species **8**, which upon reaction with butyltellurenyl iodide **9** in THF afforded the bis(butyltelluro)phosphonate intermediate **10**, as depicted in Scheme 3. The deprotonation of **10** at the expense of excess of base used, followed by the reaction with a carbonyl compound, gave the desired product **12** in a one-pot process (Scheme 3). Similar results were observed when C<sub>4</sub>H<sub>9</sub>TeBr [obtained in situ by the addition of Br<sub>2</sub> to a solution of (C<sub>4</sub>H<sub>9</sub>Te)<sub>2</sub> in THF] was used.

For the reactions described in Scheme 3, a detailed study of the experimental conditions was performed using benzaldehyde as the carbonyl component. By employing the optimal conditions described above for preparation of the phenyltellurium analogs **6a–g** (2 equiv of **7**, THF, rt), the yield of **12a** was unsatisfactory (entry 1, Table 3). We observed that a larger excess of the butyltellurophosphonate **7** and HMPA (1 mL) was required to afford good yields of the products **12a–h**. For example, benzaldehyde reacted with 4 equiv of **7** using THF as solvent, providing **12a** in 28% yield, while the yield increased to 72% by addition of

HMPA as co-solvent (entries 2 and 3, Table 3). It was also observed that the yields were highly dependent upon the amounts of **7** and LDA (entries 4–6, Table 3), with the best results achieved by using 4 equiv of **7**, 5.1 equiv of LDA and only 1 equiv of C<sub>4</sub>H<sub>9</sub>TeI (entry 6, Table 3).

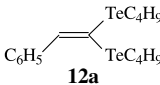
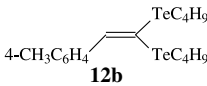
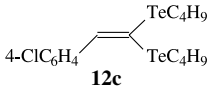
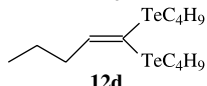
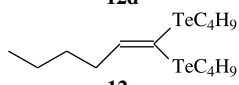
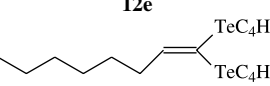
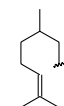
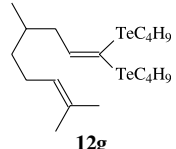
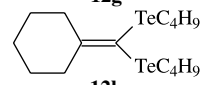
Although these large amounts of **7** and LDA could allow the generation of a great excess of the intermediate **8**, the formation of vinyl tellurides derived from the reaction of this species with the carbonyl compounds were not observed. Thus, 1-butyltelluro-2-phenylethene was not detected when benzaldehyde was employed, even in the presence of HMPA and under reflux. This observation reflects the greater reactivity of the phenyltelluro-phosphonate **2** when compared with its congener butyl tellurophosphonate **7**.<sup>19</sup>

The need of larger amounts of **7** can be explained by the lower reactivity of its anion **8-Li** towards tellurenyl halides (Scheme 3), when compared with **2-Li**. This characteristic is evidenced in the preparation of the organyltellurophosphonates **2** and **7** (Scheme 4). While phenyltellurophosphonate **2** can be prepared by the direct telluration of **3-Li** with phenyltellurenyl halides, no reaction was observed

**Scheme 4.** Synthesis of organyltellurophosphonates.**Scheme 3.** Synthesis of ketene butyltelluroacetals.**Table 3.** Synthesis of **12a** by reaction of **7** with benzaldehyde

Entry	Molar equivalents					Yield (%)
	<b>7</b>	LDA	C <sub>4</sub> H <sub>9</sub> TeI	HMPA (mL)		
1	2	3.1	1	—	26	
2	4	6.1	2	—	28	
3	4	6.1	2	1.0	72	
4	2	3.1	1	1.0	29	
5	3	4.1	1	1.0	54	
6	4	5.1	1	1.0	75	
7	3	5.1	2	1.0	53	

**Table 4.** Preparation of ketene bis(butyltelluro) acetals **12** employing the strategy of Scheme 3

Entry	R	R <sup>1</sup>	Product <b>12</b>	Reaction time (h) <sup>a</sup>	Yields (%) <sup>b</sup>
1	C <sub>6</sub> H <sub>5</sub>	H		2	75
2	4-MeC <sub>6</sub> H <sub>4</sub>	H		2	70
3	4-ClC <sub>6</sub> H <sub>4</sub>	H		2	63
4	CH <sub>3</sub> CH <sub>2</sub> CH <sub>2</sub>	H		3	87
5	CH <sub>3</sub> (CH <sub>2</sub> ) <sub>2</sub> CH <sub>2</sub>	H		3	91
6	CH <sub>3</sub> (CH <sub>2</sub> ) <sub>4</sub> CH <sub>2</sub>	H		3	92
7		H		3	90
8	-CH <sub>2</sub> (CH <sub>2</sub> ) <sub>3</sub> CH <sub>2</sub> -			3	34

<sup>a</sup> At room temperature.<sup>b</sup> Isolated yields by column chromatography.

when butyltelluryl halides were added to **3-Li**. To circumvent this problem, an alternative procedure was envisaged to prepare **7**, based on the substitution reaction of the corresponding iodomethyl phosphonate **13** by the very nucleophilic lithium butyltelluroate in 55% yield (Scheme 4).<sup>19</sup>

However, the presence of the butyltellurium group in the intermediate phosphonate **8-Li** made it possible to react with butyltellurenyl halides to afford the products **12** in the presence of HMPA, via bis(butyltelluro)phosphonate **10**.

A possible explanation for the difference of reactivity between phenyltellurenyl- and butyltellurenyl halides in the alkylation step described on Scheme 4 would be the higher electrophilicity of the phenyltellurenyl group when compared to butyltellurenyl and the largest steric hindrance of the *n*-butyl group.<sup>20</sup>

Having in hands the best conditions for the reaction described in Scheme 3, a detailed study was performed with other carbonyl compounds with the results presented in Table 4. In most cases, good to excellent yields (63–92%) were obtained by using several aromatic and aliphatic aldehydes (Table 4). The reaction of **7** with ketones was also examined. Unfortunately, we only observed reaction with cyclohexanone and in low yield (34%, entry 8, Table 4). Other ketones such as acetophenone and 3-pentanone failed to give the desired products. Although most experiments

were performed on a 1.0 mmol scale, the reactions can also be performed successfully on larger scales (e.g., 10 mmol) with comparable yields. The compounds **12a–c** (from the reaction with aromatic aldehydes) could be easily purified by column chromatography. However, the products **12d–h** were obtained as mixtures with dibutyl ditelluride, inseparable by column chromatography. In these cases, easy separations were achieved by converting the dibutyl ditelluride into dibutyl telluride, by reduction with NaBH<sub>4</sub>/EtOH and subsequent reaction with *n*-butyl bromide (see Section 4).

### 3. Conclusions

Summarizing, we have developed a simple methodology for the synthesis of new tri- and tetra-substituted ketene bis(phenyltelluro) acetals and bis(butyltelluro) acetals. Studies involving the chemical reactivity and use of these species for the preparation of naturally occurring unsaturated compounds are currently in progress.

## 4. Experimental

### 4.1. General remarks

The <sup>1</sup>H and <sup>13</sup>C NMR spectra of CDCl<sub>3</sub> solutions were recorded with a 80 MHz or a 200 MHz spectrometer, as

noted. Chemical shifts are expressed as parts per million (ppm) downfield from tetramethylsilane as an internal standard. Mass spectra (EI) were obtained at 70 eV with a Hewlett Packard EM/CG HP-5988A spectrometer and elemental analyses were performed with a Vario EL Elementar Analysis System. Merck's silica gel (230–400 mesh) was used for flash chromatography. THF was distilled over sodium/benzophenone immediately before use. The aldehydes were distilled immediately before use.

#### 4.2. General procedure for the synthesis of ketene bis(phenyltelluro) acetals 6

To a solution of LDA (3.1 mmol) in THF (4 mL) cooled to  $-78^{\circ}\text{C}$ , under nitrogen, was added dropwise a solution of **2** (0.71 g, 2 mmol) in THF (1 mL). The reaction was warmed up to  $0^{\circ}\text{C}$  and stirred 30 min at this temperature. Then, the reaction flask was cooled to  $-78^{\circ}\text{C}$  and  $\text{C}_6\text{H}_5\text{TeBr}$  (1 mmol, prepared in situ from  $\text{C}_6\text{H}_5\text{TeTeC}_6\text{H}_5$  and  $\text{Br}_2$ ) in THF (2 mL) was added. At the beginning, the  $\text{C}_6\text{H}_5\text{TeBr}$  consumption was fast but at the end of the addition, a slightly red solution remained which turns yellow in ca. 20 min. The temperature was again raised to  $0^{\circ}\text{C}$  for 30 min, the carbonyl compound (1 mmol) in THF (1 mL) was added and the reaction mixture stirred for 1–2 h at room temperature (see Table 1). The reaction was quenched by addition of water and extracted with ethyl acetate ( $3 \times 25$  mL). The organic layer was dried over  $\text{MgSO}_4$  and the solvent removed under vacuum. The residue was purified by column chromatography ( $\text{SiO}_2$ ) using hexanes as eluent. Spectral data of **6a–g** are listed below.

**4.2.1. 1,1-Bis(phenyltelluro)-2-phenyl-1-ethene 6a.** Yield 0.454 g (88%). MS  $m/z$  (rel. int.) 514 ( $\text{M}^+ - 2$ , 9.2), 309 (10.9), 207 (49.0), 77 (100.0).  $^1\text{H}$  NMR (80 MHz,  $\text{CDCl}_3$ )  $\delta$  7.00–7.50 (m, 11H); 7.60 (s, 1H); 7.65–7.93 (m, 4H);  $^{13}\text{C}$  NMR (20 MHz,  $\text{CDCl}_3$ )  $\delta$  85.8, 116.1, 118.1, 127.5, 128.1, 128.9, 129.5, 139.4, 140.6, 140.9, 145.7. Anal. Calcd for  $\text{C}_{20}\text{H}_{16}\text{Te}_2$ : C, 46.96; H, 3.15. Found: C, 46.83; H, 3.22.

**4.2.2. 1,1-Bis(phenyltelluro)-2-(2-furyl)-1-ethene 6b.** Yield 0.476 g (94%). MS  $m/z$  (rel. int.) 503 ( $\text{M}^+ - 3$ , 9.0), 205 (20.0), 77 (100.0).  $^1\text{H}$  NMR (80 MHz,  $\text{CDCl}_3$ )  $\delta$  6.10 (d,  $J=3.4$  Hz, 1H); 6.33 (dd,  $J=3.4$  Hz, 1H); 7.10–7.33 (m, 7H); 7.42 (s, 1H); 7.62–7.75 (m, 2H); 7.80–8.00 (m, 2H);  $^{13}\text{C}$  NMR (20 MHz,  $\text{CDCl}_3$ )  $\delta$  83.0, 108.8, 111.2, 116.7, 117.7, 128.2, 128.8, 129.1, 129.4, 130.5, 139.7, 141.8, 154.9. Anal. Calcd for  $\text{C}_{18}\text{H}_{14}\text{OTe}_2$ : C, 43.11; H, 2.81. Found: C, 42.82; H, 3.06.

**4.2.3. 1,1-Bis(phenyltelluro)-2-(4-nitrophenyl)-1-ethene 6c.** Yield 0.404 g (72%). MS  $m/z$  (rel. int.) 557 ( $\text{M}^+ - 4$ , 1.9), 353 (2.6), 207 (36.0), 77 (100.0).  $^1\text{H}$  NMR (80 MHz,  $\text{CDCl}_3$ )  $\delta$  7.07–7.22 (m, 2H); 7.23–7.41 (m, 6H); 7.42 (s, 1H); 7.74–7.87 (m, 4H); 7.95–8.18 (m, 2H);  $^{13}\text{C}$  NMR (20 MHz,  $\text{CDCl}_3$ )  $\delta$  93.0, 115.1, 118.1, 123.4, 128.1, 128.9, 129.2, 129.3, 129.8, 140.0, 140.6, 140.9, 146.0, 146.6. Anal. Calcd for  $\text{C}_{20}\text{H}_{15}\text{NO}_2\text{Te}_2$ : C, 43.16; H, 2.72. Found: C, 43.16; H, 2.81.

**4.2.4. 1,1-Bis(phenyltelluro)-1-pentene 6d.** Yield 0.453 g (94%). MS  $m/z$  (rel. int.) 479 ( $\text{M}^+ - 3$ , 32.0), 207 (9.0), 145 (90.0), 77 (100.0).  $^1\text{H}$  NMR (80 MHz,  $\text{CDCl}_3$ )  $\delta$  0.85 (t,  $J=$

7.1 Hz, 3H); 1.20–1.60 (m, 2H); 2.20 (q,  $J=7.1$  Hz, 2H); 6.61 (t,  $J=7.0$  Hz, 1H); 7.00–7.30 (m, 6H); 7.55–7.90 (m, 4H);  $^{13}\text{C}$  NMR (20 MHz,  $\text{CDCl}_3$ )  $\delta$  13.6, 22.0, 41.1, 80.2, 116.5, 118.1, 127.9, 129.1, 129.3, 138.6, 153.1. Anal. Calcd for  $\text{C}_{17}\text{H}_{18}\text{Te}_2$ : C, 42.76; H, 3.80. Found: C, 42.75; H, 3.70.

**4.2.5. 1,1-Bis(phenyltelluro)-3-methyl-1-butene 6e.** Yield 0.405 g (84%). MS  $m/z$  (rel. int.) 479 ( $\text{M}^+ - 3$ , 12.0), 207 (2.0), 145 (100.0), 77 (34.0).  $^1\text{H}$  NMR (80 MHz,  $\text{CDCl}_3$ )  $\delta$  0.95 (d,  $J=6.4$  Hz, 6H); 2.30–3.00 (m, 1H); 6.44 (d,  $J=8.8$  Hz, 1H); 7.00–7.30 (m, 6H); 7.55–7.80 (m, 4H);  $^{13}\text{C}$  NMR (20 MHz,  $\text{CDCl}_3$ )  $\delta$  21.9, 39.0, 127.9, 128.0, 129.1, 129.3, 138.4, 138.7, 160.4. Anal. Calcd for  $\text{C}_{17}\text{H}_{18}\text{Te}_2$ : C, 42.76; H, 3.80. Found: C, 42.81; H, 3.73.

**4.2.6. 1,1-Bis(phenyltelluro)-1,3-butadiene 6f.** Yield 0.191 g (41%). MS  $m/z$  (rel. int.) 464 ( $\text{M}^+ - 2$ , 3.8), 207 (21.5) 77 (100.0).  $^1\text{H}$  NMR (80 MHz,  $\text{CDCl}_3$ )  $\delta$  5.07 (dd,  $J=15.5$ , 2.5 Hz, 1H); 5.11 (dd,  $J=10.2$ , 2.5 Hz, 1H); 6.34–6.79 (m, 1H); 6.96 (d,  $J=10.0$  Hz, 1H); 7.03–7.40 (m, 6H); 7.62–7.82 (m, 4H);  $^{13}\text{C}$  NMR (20 MHz,  $\text{CDCl}_3$ )  $\delta$  116.2, 118.4, 118.6, 128.1, 128.5, 129.2, 129.6, 138.1, 139.4, 139.6, 147.6. Anal. Calcd for  $\text{C}_{16}\text{H}_{14}\text{Te}_2$ : C, 41.64; H, 3.06. Found: C, 41.47; H, 2.94.

**4.2.7. 1,1-Bis(phenyltelluro)-2-cyclohexanyl-ethene 6g.** Yield 0.081 g (16%). MS  $m/z$  (rel. int.) 506 ( $\text{M}^+ - 2$ , 13.2), 299 (9.0), 77 (100.0).  $^1\text{H}$  NMR (80 MHz,  $\text{CDCl}_3$ )  $\delta$  1.35–1.55 (m, 6H); 2.50–2.75 (m, 4H); 7.00–7.30 (m, 6H); 7.61–7.49 (m, 4H). Anal. Calcd for  $\text{C}_{19}\text{H}_{20}\text{Te}_2$ : C, 45.32; H, 4.00. Found: C, 45.31; H, 3.99.

#### 4.3. General procedure for the synthesis of ketene bis(butyltelluro) acetals 12

To a solution of LDA (5.1 mmol) in THF (4 mL) cooled to  $-78^{\circ}\text{C}$ , under nitrogen, was added, dropwise, a solution of **7** (1.34 g, 4 mmol) in THF (2 mL). The reaction was warmed up to  $0^{\circ}\text{C}$  and stirred 30 min at this temperature. The reaction flask was cooled to  $-78^{\circ}\text{C}$ , and  $\text{BuTeI}$  (1 mmol, prepared in situ from  $\text{C}_4\text{H}_9\text{TeTeC}_4\text{H}_9$  and  $\text{I}_2$ ) in THF (2 mL) was added. At the beginning, the tellurenyl halide consumption was fast, and at the end of the addition, a slightly red solution remained, which turns yellow in ca. 20 min. The temperature was again raised to  $0^{\circ}\text{C}$  for 30 min, the carbonyl compound (1 mmol) in HMPA (1 mL) was added and the reaction mixture stirred for 2–3 h at room temperature (see Table 4). The reaction was quenched by addition of water and extracted with ethyl acetate ( $3 \times 25$  mL). The organic layer was dried over  $\text{MgSO}_4$  and the solvent removed under vacuum. The residue was purified by column chromatography ( $\text{SiO}_2$ ) and eluted with hexanes, yielding **12a–c** (pure materials) and **12d–h** [mixture with  $(\text{C}_4\text{H}_9\text{Te})_2$ ]. For the products **12d–h**, the mixture was transferred to a Erlenmeyer flask, diluted with ethyl acetate (10 mL), 95% ethanol (5 mL) and water (10 mL). Then, *n*-butylbromide (0.11 mL, 1.0 mmol) and  $\text{NaBH}_4$  (0.038 g, 1 mmol) were added (to transform the dibutyltelluride into the corresponding dibutyltelluride, which is more easily removed by distillation). After this treatment, the product was extracted with ethyl acetate ( $3 \times 20$  mL) and washed with water, the organic phase was dried over anhydrous  $\text{MgSO}_4$  and the solvent evaporated under reduced pressure.

The dibutyltelluride was distilled off from the mixture using a Kugelrohr apparatus (50 °C/0.1 mmHg) leaving the products **12d–h** as pure materials. Spectral data of **12a–h** are listed below.

**4.3.1. 1,1-Bis(butyltelluro)-2-phenyl-1-ethene 12a.** Yield 0.357 g (75%). MS *m/z* (rel. int.) 474 ( $M^+ - 2$ , 12.3), 102 (15.6), 57 (100.0).  $^1\text{H NMR}$  (200 MHz,  $\text{CDCl}_3$ )  $\delta$  0.86 (t,  $J=7.3$  Hz, 3H); 0.94 (t,  $J=7.3$  Hz, 3H); 1.25–1.55 (m, 4H); 1.6–1.8 (m, 2H); 1.8–2.0 (m, 2H); 2.74 (t,  $J=7.5$  Hz, 2H); 2.92 (t,  $J=7.5$  Hz, 2H); 7.20–7.38 (m, 5H); 7.96 (s, 1H);  $^{13}\text{C NMR}$  (50 MHz,  $\text{CDCl}_3$ )  $\delta$  12.8, 13.4, 13.5, 15.6, 25.1, 25.2, 33.4, 33.6, 79.6, 127.4, 128.0, 128.1, 141.0, 149.7. Anal. Calcd for  $\text{C}_{16}\text{H}_{24}\text{Te}_2$ : C, 40.75; H, 5.13. Found: C, 41.01; H, 5.10.

**4.3.2. 1,1-Bis(butyltelluro)-2-(4-methylphenyl)-1-ethene 12b.** Yield 0.343 g (70%). MS *m/z* (rel. int.) 488 ( $M^+ - 2$ , 13.8), 115 (64.7), 57 (100.0).  $^1\text{H NMR}$  (200 MHz,  $\text{CDCl}_3$ )  $\delta$  0.86 (t,  $J=7.2$  Hz, 3H); 0.93 (t,  $J=7.2$  Hz, 3H); 1.22–1.52 (m, 4H); 1.63–1.78 (m, 2H); 1.80–1.95 (m, 2H); 2.31 (s, 3H); 2.74 (t,  $J=7.4$  Hz, 2H); 2.89 (t,  $J=7.4$  Hz, 2H); 7.20 (d,  $J=7.9$  Hz, 2H); 7.11 (d,  $J=7.9$  Hz, 2H); 7.95 (s, 1H);  $^{13}\text{C NMR}$  (50 MHz,  $\text{CDCl}_3$ )  $\delta$  12.5, 13.4, 15.5, 21.1, 24.9, 25.0, 33.2, 33.5, 78.6, 127.8, 128.5, 137.0, 137.9, 149.8. Anal. Calcd for  $\text{C}_{17}\text{H}_{26}\text{Te}_2$ : C, 42.05; H, 5.40. Found: C, 42.27; H, 5.27.

**4.3.3. 1,1-Bis(butyltelluro)-2-(4-chlorophenyl)-1-ethene 12c.** Yield 0.321 g (63%). MS *m/z* (rel. int.) 508 ( $M^+ - 2$ , 8.8), 136 (19.1), 57 (100.0).  $^1\text{H NMR}$  (200 MHz,  $\text{CDCl}_3$ )  $\delta$  0.86 (t,  $J=7.1$  Hz, 3H); 0.93 (t,  $J=7.1$  Hz, 3H); 1.22–1.53 (m, 4H); 1.63–1.78 (m, 2H); 1.80–1.96 (m, 2H); 2.74 (t,  $J=7.5$  Hz, 2H); 2.90 (t,  $J=7.5$  Hz, 2H); 7.22–7.31 (m, 4H); 7.86 (s, 1H);  $^{13}\text{C NMR}$  (50 MHz,  $\text{CDCl}_3$ )  $\delta$  13.0, 13.3, 13.4, 15.8, 25.0, 25.1, 33.2, 33.5, 81.1, 128.1, 129.3, 133.0, 139.1, 147.7. Anal. Calcd for  $\text{C}_{16}\text{H}_{23}\text{ClTe}_2$ : C, 37.98; H, 4.58. Found: C, 38.78; H, 4.37.

**4.3.4. 1,1-Bis(butyltelluro)-1-pentene 12d.** Yield 0.385 g (87%). MS *m/z* (rel. int.) 440 ( $M^+ - 2$ , 8.3), 255 (9.1), 57 (100.0).  $^1\text{H NMR}$  (200 MHz,  $\text{CDCl}_3$ )  $\delta$  0.92 (t,  $J=7.3$  Hz, 9H); 1.31–1.50 (m, 6H); 1.69–1.90 (m, 4H); 2.22 (q,  $J=7.1$  Hz, 2H); 2.78 (t,  $J=7.4$  Hz, 4H); 6.72 (t,  $J=6.9$  Hz, 1H);  $^{13}\text{C NMR}$  (50 MHz,  $\text{CDCl}_3$ )  $\delta$  11.8, 13.5, 13.6, 13.7, 22.1, 25.2, 33.4, 33.9, 41.4, 75.9, 154.3. Anal. Calcd for  $\text{C}_{13}\text{H}_{26}\text{Te}_2$ : C, 35.69; H, 5.99. Found: C, 35.40; H, 5.77.

**4.3.5. 1,1-Bis(butyltelluro)-1-hexene 12e.**<sup>16b</sup> Yield 0.415 g (91%).  $^1\text{H NMR}$  (200 MHz,  $\text{CDCl}_3$ )  $\delta$  0.88–0.95 (m, 9H); 1.34–1.50 (m, 8H); 1.69–1.85 (m, 4H); 2.25 (q,  $J=7.0$  Hz, 2H); 2.77 (2t,  $J=7.3$  Hz, 4H); 6.71 (t,  $J=6.9$  Hz, 1H);  $^{13}\text{C NMR}$  (50 MHz,  $\text{CDCl}_3$ )  $\delta$  11.7, 13.4, 13.6, 13.9, 22.1, 25.1, 30.9, 33.3, 33.8, 39.0, 77.6, 154.4.

**4.3.6. 1,1-Bis(butyltelluro)-1-octene 12f.**<sup>16b</sup> Yield 0.445 g (92%).  $^1\text{H NMR}$  (200 MHz,  $\text{CDCl}_3$ )  $\delta$  0.85–0.95 (m, 9H); 1.28–1.50 (m, 12H); 1.69–1.89 (m, 4H); 2.24 (q,  $J=7.0$  Hz, 2H); 2.77 (t,  $J=7.2$  Hz, 2H); 2.78 (t,  $J=7.2$  Hz, 2H); 6.71 (t,  $J=6.9$  Hz, 1H);  $^{13}\text{C NMR}$  (50 MHz,  $\text{CDCl}_3$ )  $\delta$  11.7, 13.4, 13.6, 14.0, 22.5, 25.1, 28.7, 28.8, 31.6, 33.3, 33.8, 39.3, 75.8, 154.5.

**4.3.7. 1,1-Bis(butyltelluro)-4,8-dimethyl-1,7-nonadiene 12g.** Yield 0.472 g (90%). MS *m/z* (rel. int.) 506 ( $M^+ - 3$ ,  $-\text{CH}_3$ , 7.5), 451 (100.0), 313 (34.5), 183 (67.0), 57 (62.0).  $^1\text{H NMR}$  (200 MHz,  $\text{CDCl}_3$ )  $\delta$  0.92 (t,  $J=7.0$  Hz, 9H); 1.60 (s, 3H); 1.68 (s, 3H); 1.00–2.50 (m, 15H); 2.78 (t,  $J=7.5$  Hz, 4H); 5.09 (t,  $J=6.5$  Hz, 1H); 6.73 (t,  $J=6.9$  Hz, 1H);  $^{13}\text{C NMR}$  (50 MHz,  $\text{CDCl}_3$ )  $\delta$  11.7, 13.5, 13.8, 17.6, 19.6, 25.2, 25.6, 32.8, 33.5, 33.9, 36.7, 46.4, 76.7, 124.6, 131.1, 153.5. Anal. Calcd  $\text{C}_{19}\text{H}_{36}\text{Te}_2$ : C, 43.91; H, 6.98. Found: C, 43.57; H, 6.81.

**4.3.8. 1,1-Bis(butyltelluro)-2-cyclohexanyl-ethene 12h.** Yield 0.159 g (34%). MS *m/z* (rel. int.) 466 ( $M^+ - 2$ , 34.2), 95 (90.4), 41 (100.0).  $^1\text{H NMR}$  (200 MHz,  $\text{CDCl}_3$ )  $\delta$  0.91 (t,  $J=7.0$  Hz, 6H); 1.31–1.45 (m, 4H); 1.47–1.53 (m, 6H); 1.65–1.83 (m, 4H); 2.62 (t,  $J=7.0$  Hz, 4H); 2.75 (t,  $J=7.0$  Hz, 4H);  $^{13}\text{C NMR}$  (50 MHz,  $\text{CDCl}_3$ )  $\delta$  13.5, 14.4, 25.2, 26.4, 28.6, 33.6, 41.5, 74.3, 161.1. Anal. Calcd  $\text{C}_{15}\text{H}_{28}\text{Te}_2$ : C, 38.86; H, 6.09. Found: C, 38.95; H, 6.15.

### Acknowledgements

The authors acknowledge the financial support provided by SCT-RS, FAPERGS, CNPq and CAPES.

### References and notes

- For reviews on preparation and reactivity of vinyl tellurides, see: (a) Petragnani, N.; Stefani, H. A. *Tetrahedron* **2005**, *61*, 1613. (b) Vieira, M. L.; Zinn, F. K.; Comasseto, J. V. *J. Braz. Chem. Soc.* **2001**, *12*, 586. (c) Barrientos-Astigarraga, R. E.; Castalani, P.; Comasseto, J. V.; Formiga, H. B.; Silva, N. C.; Sumida, C. Y.; Vieira, M. L. *J. Organomet. Chem.* **2001**, *623*, 43. (d) Comasseto, J. V.; Barrientos-Astigarraga, R. E. *Aldrichim. Acta* **2000**, *33*, 66. (e) Comasseto, J. V.; Ling, L. W.; Petragnani, N.; Stefani, H. A. *Synthesis* **1997**, 373.
- Petragnani, N. *Best Synthetic Methods—Tellurium in Organic Synthesis*; Academic, 1994.
- (a) Huang, Y. Z.; Mo, X. S. *Synlett* **1998**, 93. (b) Mo, X. S.; Huang, Y. Z. *Tetrahedron Lett.* **1995**, *36*, 3539. (c) Dabdoub, M. J.; Begnini, M. L.; Cassol, T. M.; Guerrero, P. G., Jr.; Silveira, C. C. *Tetrahedron Lett.* **1995**, *36*, 7623. (d) Hihiro, T.; Kambe, N.; Ogawa, A.; Miyoshi, N.; Murai, S.; Sonoda, N. *Angew. Chem., Int. Ed. Engl.* **1987**, *26*, 1187. (e) Barros, S. M.; Comasseto, J. V.; Berriel, J. N. *Tetrahedron Lett.* **1989**, *30*, 7353. (f) Barros, S. M.; Dabdoub, M. J.; Dabdoub, V. B.; Comasseto, J. V. *Organometallics* **1989**, *8*, 1661. (g) Ogawa, A.; Tsuboi, Y.; Obayashi, R.; Yokoyama, K.; Ryu, I.; Sonoda, N. *J. Org. Chem.* **1994**, *59*, 1600. (h) Dabdoub, M. J.; Dabdoub, V. B. *Tetrahedron* **1995**, *51*, 9839. (i) Dabdoub, M. J.; Jacob, R. G.; Ferreira, J. T. B.; Dabdoub, V. B.; Marques, F. A. *Tetrahedron Lett.* **1999**, *40*, 7159. (j) Dabdoub, M. J.; Dabdoub, V. B.; Comasseto, J. V. *Tetrahedron Lett.* **1992**, *33*, 2261. (k) Dabdoub, M. J.; Dabdoub, V. B.; Guerrero, P. G., Jr.; Silveira, C. C. *Tetrahedron* **1997**, *53*, 4199.
- Huang, Y. Z.; Mo, X. S. *Tetrahedron Lett.* **1998**, *39*, 1945.
- Kanda, T.; Sugiro, T.; Kambe, N.; Sonoda, N. *Phosphorus Sulfur Silicon Relat. Elem.* **1992**, *67*, 103.
- (a) Tucci, F. C.; Chieffi, A.; Comasseto, J. V.; Marino, J. P.

- J. Org. Chem.* **1996**, *61*, 4975. (b) Comasseto, J. V.; Berriel, J. *Synth. Commun.* **1990**, *20*, 1681. (c) Moraes, D. N.; Barrientos-Astigarraga, R. E.; Castelani, P.; Comasseto, J. V. *Tetrahedron* **2000**, *56*, 3327. (d) Tucci, F. C.; Chieffi, A.; Comasseto, J. V. *Tetrahedron Lett.* **1992**, *33*, 5721. (e) Araujo, M. A.; Barrientos-Astigarraga, R. E.; Ellensohn, R. M.; Comasseto, J. V. *Tetrahedron Lett.* **1999**, *40*, 5115. (f) Barrientos-Astigarraga, R. E.; Moraes, D. N.; Comasseto, J. V. *Tetrahedron Lett.* **1999**, *40*, 265. (g) Marino, J. P.; Tucci, F. C.; Comasseto, J. V. *Synlett* **1993**, 761. (h) Araujo, M. A.; Comasseto, J. V. *Synlett* **1995**, 1145. (i) Huang, X.; Zhao, C. Q. *Synth. Commun.* **1997**, *27*, 237. (j) Chieffi, A.; Comasseto, J. V. *Tetrahedron Lett.* **1995**, *35*, 4063. (k) Chieffi, A.; Comasseto, J. V. *Synlett* **1995**, 671. (l) Huang, Y. Z.; Mo, X. S.; Wang, L. *Tetrahedron Lett.* **1998**, *39*, 419.
7. (a) Dabdoub, M. J.; Dabdoub, V. B.; Marino, J. P. *Tetrahedron Lett.* **2000**, *41*, 433. (b) Dabdoub, M. J.; Dabdoub, V. B.; Marino, J. P. *Tetrahedron Lett.* **2000**, *41*, 437. (c) Terao, J.; Kambe, N.; Sonoda, N. *Tetrahedron Lett.* **1996**, *37*, 4741.
8. Jang, W. B.; Oh, D. Y.; Lee, C. W. *Tetrahedron Lett.* **2000**, *41*, 5103.
9. Nishibayashi, Y.; Cho, C. S.; Ohe, K.; Uemura, S. *J. Organomet. Chem.* **1996**, *526*, 335.
10. (a) Zeni, G.; Comasseto, J. V. *Tetrahedron Lett.* **1999**, *40*, 4619. (b) Silveira, C. C.; Braga, A. L.; Vieira, A. S.; Zeni, G. *J. Org. Chem.* **2003**, *68*, 662.
11. (a) Uemura, S.; Fukuzawa, S.; Patil, S. R. *J. Organomet. Chem.* **1983**, *243*, 9. (b) Gerard, J.; Hevesi, L. *Tetrahedron* **2001**, *57*, 9109. (c) Huang, X.; Wang, Y. P. *Tetrahedron Lett.* **1996**, *37*, 7417. (d) Uemura, S.; Fukuzawa, S. I. *Tetrahedron Lett.* **1982**, *23*, 1181.
12. For a review on Pd(II) catalyzed homo- and cross-coupling of vinyl tellurides, see: Zeni, G.; Braga, A. L.; Stefani, H. A. *Acc. Chem. Res.* **2003**, *36*, 731.
13. (a) Uemura, S.; Ohe, K.; Kim, J. R.; Kudo, K.; Sugita, N. *J. Chem. Soc., Chem. Commun.* **1985**, 271. (b) Ohe, K.; Takahashi, H.; Uemura, S.; Sugita, N. *J. Organomet. Chem.* **1987**, *326*, 35. (c) Ohe, K.; Takahashi, H.; Uemura, S.; Sugita, N. *J. Org. Chem.* **1987**, *52*, 4859.
14. Kauffmann, T. *Angew. Chem., Int. Ed. Engl.* **1982**, *21*, 410.
15. Zeni, G.; Perin, G.; Cella, R.; Jacob, R. G.; Braga, A. L.; Silveira, C. C.; Stefani, H. A. *Synlett* **2002**, *6*, 975.
16. (a) Sung, J. W.; Park, C. P.; Gil, J. M.; Oh, D. Y. *J. Chem. Soc., Perkin Trans. 1* **1997**, 591. (b) Dabdoub, M. J.; Begnini, M. L.; Guerrero, P. G., Jr. *Tetrahedron* **1998**, *54*, 2371. (c) Stang, P. J.; Roberts, K. A.; Lynch, L. E. *J. Org. Chem.* **1984**, *49*, 1653. (d) Silveira, C. C.; Perin, G.; Braga, A. L. *Tetrahedron Lett.* **1995**, *36*, 7361.
17. (a) Silveira, C. C.; Perin, G.; Braga, A. L.; Petraghani, N. *Synlett* **1995**, 58. (b) Silveira, C. C.; Perin, G.; Boeck, P.; Braga, A. L.; Petraghani, N. *J. Organomet. Chem.* **1999**, *584*, 44. (c) Silveira, C. C.; Perin, G.; Braga, A. L.; Dabdoub, M. J.; Jacob, R. G. *Tetrahedron* **1999**, *55*, 7421. (d) Silveira, C. C.; Perin, G.; Braga, A. L.; Dabdoub, M. J.; Jacob, R. G. *Tetrahedron* **2001**, *57*, 5953.
18. For a review on preparation of vinyl chalcogenides by Wittig and Horner–Wittig reactions, see: Silveira, C. C.; Perin, G.; Jacob, R. G.; Braga, A. L. *Phosphorus, Sulfur Silicon* **2001**, *172*, 55.
19. Lee, C. W.; Koh, Y. J.; Oh, D. Y. *J. Chem. Soc., Perkin Trans. 1* **1994**, 717.
20. For a discussion regarding the steric factors see: Newman, M. S. *J. Am. Chem. Soc.* **1950**, *72*, 4783.

# Maleimide cycloadditions by sulfinyldienes: is the sulfur configuration the only controller of the diastereofacial selectivity?

Maria C. Aversa,<sup>a</sup> Anna Barattucci,<sup>a</sup> Paola Bonaccorsi,<sup>a,\*</sup> Cristina Faggi,<sup>b</sup> Eszter Gacs-Baitz,<sup>c</sup> Assunta Marrocchi,<sup>d</sup> Lucio Minuti<sup>d,\*</sup> and Aldo Taticchi<sup>d</sup>

<sup>a</sup>Dipartimento di Chimica organica e biologica, Università degli Studi di Messina, Salita Sperone 31 (vill. S. Agata), 98166 Messina, Italy

<sup>b</sup>Centro interdipartimentale di Cristallografia, Polo Scientifico, Università degli Studi di Firenze, via della Lastruccia 13, 50019 Sesto Fiorentino, Firenze, Italy

<sup>c</sup>Central Institute for Chemistry, Hungarian Academy of Sciences, PO Box 17, H-1525 Budapest, Hungary

<sup>d</sup>Dipartimento di Chimica, Università degli Studi di Perugia, Via Elce di Sotto 8, 06123 Perugia, Italy

Received 24 March 2005; revised 16 May 2005; accepted 26 May 2005

Available online 22 June 2005

**Abstract**—Cyclohexylsulfinyl-3-methyl-1,3-butadienes **5**, **6**, and 1-[1-(cyclohexylsulfinyl)ethenyl]cyclohexene (**7**), easily prepared from cyclohexanethiol (**1**) via transient cyclohexanesulfenic acid (**4**), were reacted with *N*-phenylmaleimide under different conditions, at normal and high pressure. The stereochemical outcome of these cycloadditions contributes a better understanding of the relationships among different factors controlling facial diastereoselection.

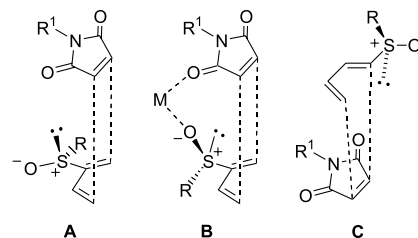
© 2005 Elsevier Ltd. All rights reserved.

## 1. Introduction

In the last 20 years a number of articles have dealt with the synthetic scope and limitations of the sulfinyl group acting as stereodifferentiating element in Diels–Alder (DA) cycloadditions.<sup>1</sup> The electronic and structural features of the chiral sulfur atom, bearing the strongly electron-withdrawing sulfinyl oxygen, the sterically undemanding lone pair, and the alkyl or aryl group, assure, in almost all cases, very good stereoselection results. In particular, the stereochemical behaviour of sulfinyl dienes, in which the sulfoxide sulfur is directly linked to the diene skeleton, depends upon the position of the sulfoxide moiety within the diene, the electronic and steric nature of dienophile, and eventually the involvement of a catalyst in the cycloaddition. It has been frequently observed that dienophiles such as maleimides approach 2-sulfinyl dienes from their less hindered and more nucleophilic face (the one bearing the electronic lone pair) with the sulfinyl group adopting a conformation along the C(diene)–S bond in which the electrostatic repulsions between the sulfinyl oxygen and the heteroatoms of the dienophile are minimised (**A** in Fig. 1).<sup>2</sup>

**Keywords:** Cyclohexylsulfinyl dienes; Diastereofacial selectivity; Diels–Alder cycloadditions; *N*-Phenylmaleimide.

\* Corresponding authors. Tel.: +39 090 6765187; fax: +39 090 393895 (P.B.); tel.: +39 075 5855545; fax: +39 075 5855560 (L.M.); e-mail addresses: paolab@isengard.unime.it; lucio@unipg.it



**Figure 1.** Favoured *endo*-approaches of maleimides in Diels–Alder reactions with sulfinyl dienes.

The presence of a catalyst, able to link the basic centres of the two reagents, changes the conformational preference of the diene to allow this association (**B** in Fig. 1). In the less reactive 1-sulfinyl dienes the favoured approach of maleimide takes place again from the less hindered face of the diene that adopts a conformation exhibiting the greatest distance between the oxygen atoms of diene and dienophile (**C** in Fig. 1).<sup>3</sup>

Table 1 illustrates the preferred diene face for dienophile *endo*-approach in uncatalyzed cycloadditions of several 2-sulfinyl dienes with maleimides. We have chosen to tabulate all the literature data corroborated by X-ray analysis of the major (or unique) cycloadduct. In order to facilitate the reading of the paper, the sulfur CIP descriptors have been converted into sulfur *pseudo*-descriptors (*pR* or *pS*, column 6 in Table 1) obtained by assigning arbitrarily

**Table 1.** Literature data concerning Diels–Alder *endo*-diastereoselective cycloadditions of maleimides with

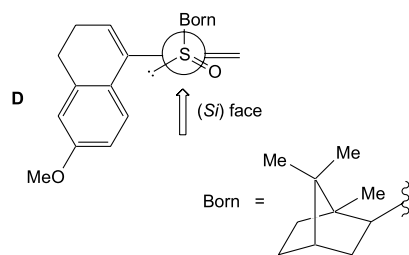
Entry	R	R <sup>1</sup>	R <sup>3</sup> /R <sup>4</sup>	Diene config.	Sulfur <i>pseudo</i> -config.	Dienophile	Preferred diene face for dienophile <i>endo</i> -approach	Ref.
1	<i>p</i> MeC <sub>6</sub> H <sub>4</sub>	H	H/Me	( <i>R</i> <sub>S</sub> , <i>E</i> )	( <i>pS</i> )	Maleimide	( <i>Re</i> )	2a
2		H	H/H	( <i>R</i> <sub>S</sub> )	( <i>pR</i> )	NPM	( <i>Si</i> )	2b
3		H	H/OMe	( <i>R</i> <sub>S</sub> , <i>E</i> )	( <i>pR</i> )	NPM	( <i>Si</i> )	2c
4		H	H/OMe	( <i>S</i> <sub>S</sub> , <i>E</i> )	( <i>pS</i> )	NPM	( <i>Re</i> )	2d
5		H	–(CH <sub>2</sub> ) <sub>4</sub> –	( <i>R</i> <sub>S</sub> )	( <i>pR</i> )	NPM	( <i>Si</i> )	2e
6		H		( <i>S</i> <sub>S</sub> )	( <i>pS</i> )	NPM	( <i>Si</i> )	4
7	C <sub>6</sub> H <sub>5</sub>	Me	H/H	( <i>R</i> <sub>S</sub> , <i>Z</i> )	( <i>pS</i> )	NPM	( <i>Re</i> )	2f

the priority to the sulfinyl oxygen, followed by the diene system, and finally by alkyl or aryl substituent at sulfur atom. Furthermore, the face descriptor is assigned by referring to the diene carbon directly linked to the sulfur atom (column 8 in Table 1). Apart from the example shown in entry 6, the reported cases are consistent with sulfur configuration controlling the diastereofacial selectivity: maleimides prefer the approach to (*pS*)-2-sulfinyl dienes from their less hindered (*Re*) face (entries 1, 4, and 7), and vice-versa the (*Si*) face of approach is chosen by dienophile when (*pR*) is the configuration at the sulfinyl sulfur of the diene (entries 2, 3, and 5).

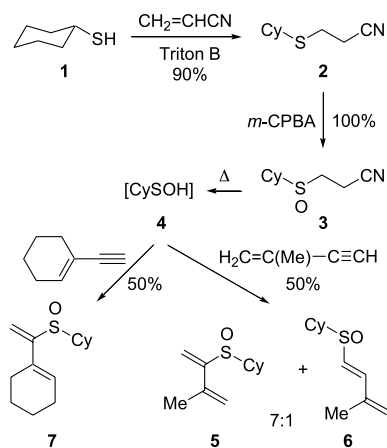
In the addition of *N*-phenylmaleimide (NPM) to the enantiopure 2-sulfinyl diene reported in entry 6 of Table 1, low *endo*/*exo*-diastereoselectivity and complete but reversed diastereofacial selectivity in the *endo*-approach were observed. A tentative rationalisation of these results was based on the high steric requirements of both diene and dienophile,<sup>4</sup> such that the less sterically congested *exo*-approaches occurred in high percentage but without significant facial discrimination, while the more sterically demanding *endo*-approach happened with complete facial

selection. NPM cycloadded to the diene from a face opposite to the one normally observed for analogous sulfinyl dienes (Table 1, entries 1–5, and 7) and this unexpected result was explained by proposing a preferred diene **D** conformation (Fig. 2) in which the electrostatic repulsion between the sulfinyl oxygen and the  $\pi$ -system of the fused benzene ring is avoided in the transition state of the cycloaddition. In other occasions, we could observe how the diene steric requirements dramatically affected the stereochemical results of DA cycloadditions involving 2-sulfinyl dienes,<sup>5</sup> and we wondered if the sulfur configuration could be regarded as the only controller of the diastereofacial selectivity.

For a deeper understanding of this matter, we accomplished the synthesis of 1- and 2-sulfinyl dienes with a cyclohexyl moiety directly linked to the sulfinyl sulfur atom, and substituents in 3 or 3,4-positions of the diene skeleton. In



**Figure 2.** Preferred conformation **D** of (*S*<sub>S</sub>)-4-{1-[(1*S*)-*exo*-2-bornylsulfinyl]ethenyl}-1,2-dihydro-7-methoxynaphthalene in its Diels–Alder *endo*-approach with NPM (entry 6 in Table 1).



**Scheme 1.**

**Table 2.** Reaction conditions of the Diels–Alder cycloadditions of dienes **5–7** with *N*-phenylmaleimide (NPM)

Entry	Reactants (equiv ratio) <sup>a</sup>	Solvent	Conditions	Products (ratio)	Yield <sup>b</sup> (%)
1	<b>5</b> /NPM (1:5)	CH <sub>2</sub> Cl <sub>2</sub> /CHCl <sub>3</sub> (3:1)	40 °C, 60 h, 1 bar	<b>8</b>	55
2	<b>5</b> /NPM (1:5)	CH <sub>2</sub> Cl <sub>2</sub> /CHCl <sub>3</sub> (3:1)	25 °C, 20 h, 8 kbar	<b>8</b>	53
3	<b>5</b> /NPM (1:5)	PhMe	70 °C, 20 h, 1 bar	<b>8</b>	48
4	<b>5</b> /NPM (1:5)	CH <sub>2</sub> Cl <sub>2</sub>	50 °C, 18 h, 8 kbar	<b>8</b>	46
5	<b>7</b> /NPM (1:6)	PhMe	70 °C, 21 h, 1 bar	<b>9/10</b> (5.3:1)	47
6	<b>7</b> /NPM (1:5.7)	CH <sub>2</sub> Cl <sub>2</sub>	25 °C, 24 h, 8 kbar	<b>9</b>	69
7	<b>7</b> /NPM (1:5.4)	CH <sub>2</sub> Cl <sub>2</sub>	50 °C, 19 h, 8 kbar	<b>9</b>	45
8	<b>6</b> /NPM (1:5)	PhMe	70 °C, 24 h, 1 bar	—	—
9	<b>6</b> /NPM (1:5)	CH <sub>2</sub> Cl <sub>2</sub>	25 °C, 24 h, 8 kbar	<b>11/12</b> (3.6:1)	60

<sup>a</sup> Diene concentration 0.1 M.<sup>b</sup> The yields refer to isolated cycloadducts.

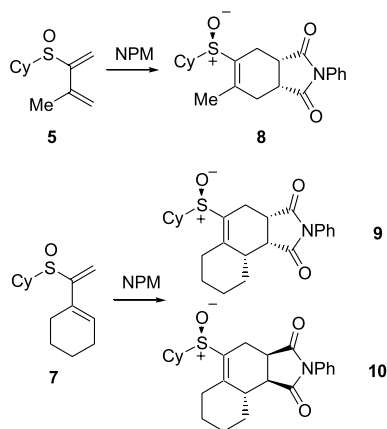
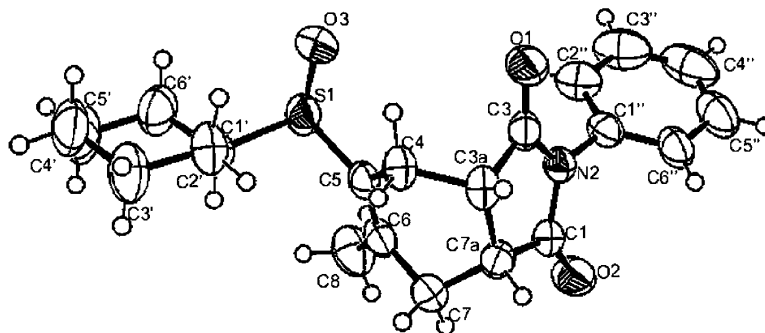
this paper, we report the results of the DA reactions of these dienes with NPM under thermal conditions, at normal and high pressure. It is well known that high pressure can accelerate DA reactions, therefore allowing cycloadditions of poorly reactive and/or heat sensitive substrates to be carried out under mild conditions.<sup>6</sup> We have chosen NPM as dienophile mainly for its intrinsic ability to produce crystalline cycloadducts that could be subjected to X-ray analysis and give us unassailable stereochemical responses.

## 2. Results and discussion

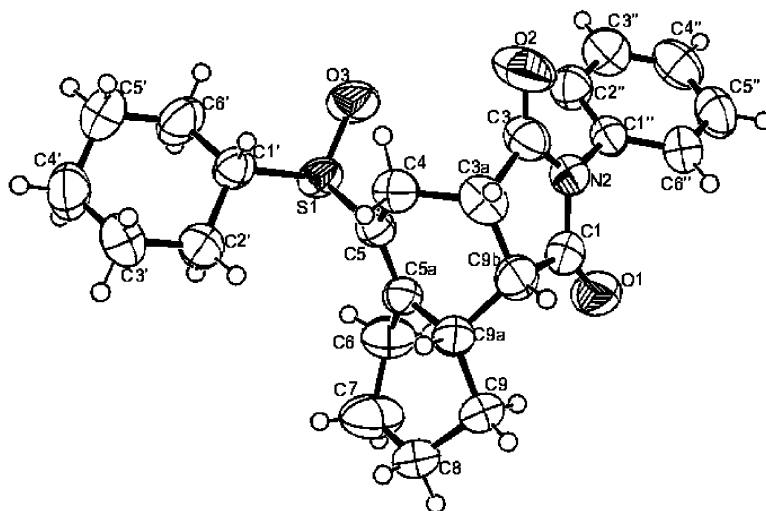
Cyclohexanethiol (**1**) was reacted with acrylonitrile in the presence of trimethylbenzylammonium hydroxide (Triton B) to give the thioether **2** in 90% yield (Scheme 1).<sup>7</sup> Oxidation of **2** with 3-chloroperbenzoic acid (*m*-CPBA)

gave cyclohexyl sulfoxide **3**, that constitutes suitable precursor of transient sulfenic acid **4**.<sup>8</sup> Acid **4**, thermally generated in the presence of the enyne acceptor, *syn*-added to the triple bond of 2-methyl-1-buten-3-yne leading to the formation of dienes **5** and **6** in 7:1 ratio and 50% overall yield. Cyclohexylsulfinyl dienes **5** and **6** were easily separated by column chromatography and fully characterised. 1-[1-(Cyclohexylsulfinyl)ethenyl]cyclohexene (**7**) was obtained in useful yield (50%) as the product of the completely regioselective addition of sulfenic acid **4** to the triple bond of 1-ethynylcyclohexene.

Diene **5** cycloadded to NPM under different reaction conditions, as reported in Table 2, at atmospheric and high pressure (Scheme 2). The reaction occurred with complete facial diastereoselection leading to the unique cycloadduct **8**. Results listed in Table 2 show that the increased pressure accelerates DA process (compare entries 1 and 2) but does not affect either stereochemical results or yields. Crystallisation from ethyl acetate of compound **8** afforded crystals suitable for X-ray analysis whose result, shown in Figure 3, confirmed the structural determination conducted by extensive NMR investigation. Since the chemical shifts of H<sub>2</sub>-4 and H<sub>2</sub>-7 were very close in <sup>1</sup>H spectra, distinction between them was made by the observed NOE involving the methyl protons and nearest H-7. Furthermore, H-3a and H-7a were assigned by selective decoupling of H<sub>2</sub>-4 and H<sub>2</sub>-7, and by <sup>1</sup>H–<sup>13</sup>C hetero-correlated experiments. Finally, the 9.0 Hz value of *J*<sub>3a,7a</sub> confirmed the *cis*-arrangement of H-3a and H-7a, while the extended boat conformation of the cyclohexene ring, observed also in the solid state (Fig. 3), followed from the coupling constant values *J*<sub>3a,4</sub> (7.1, 2.4 Hz) and *J*<sub>7,7a</sub> (6.0, 2.9 Hz). X-ray analysis of adduct **8** allowed the

**Scheme 2.****Figure 3.** Perspective view of the structure of **8** with probability displacements ellipsoids representing all non-H atoms. The atom-numbering scheme is consistent with the systematic nomenclature numbering.





**Figure 4.** Perspective view of the structure of **9** with probability displacements ellipsoids representing all non-H atoms. The atom-numbering scheme is consistent with the systematic nomenclature numbering.

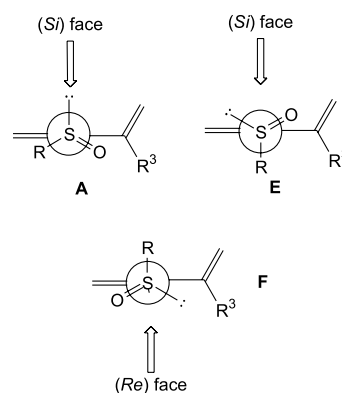
unambiguous assignment of the configuration to the newly formed stereocentres **3a** and **7a**, in relation to the configuration of the sulfinyl sulfur atom, as ( $3aS^*,7aR^*,R_S^*$ ). This stereochemical outcome is consistent with NPM *endo*-approach to the (*Re*) face of diene ( $R_S$ )-**5** (analogously to entry **6** in Table 1).

Entries 5–7 in Table 2 concern the results of DA reaction of NPM with inner-outer diene **7**. When cycloaddition was performed in toluene, at 70 °C, a complete  $\pi$ -facial selectivity was observed and two cycloadducts **9** (*endo*) and **10** (*exo*) were obtained in 5:1 ratio, 47% total yield (Scheme 2). High pressure (entries 6 and 7 in Table 2) led to complete *endo/exo*-diastereoselectivity, and *endo*-cycloadduct **9** was isolated as unique and crystalline product of reaction. The best yield (69%, entry 6 in Table 2) was obtained when cycloaddition was performed under the pressure of 8 kbar, at 25 °C in dichloromethane. Cycloadduct **9** was recrystallised from ethyl acetate and its X-ray structure is shown in Figure 4. The *cis*-arrangement of H-**3a**, H-**9a**, and H-**9b** is a consequence of the *endo*-approach of NPM that occurs on the (*Re*) face of ( $R_S$ )-sulfinyldiene **7**, as demonstrated by the ( $3aS^*,9aS^*,9bR^*,R_S^*$ ) configuration of **9**. An extensive NMR investigation was performed on both cycloadducts **9** and **10**, the structure determination of the latest being based on these measurements. All the experiments were performed in  $CDCl_3/C_6D_6$  mixtures of different ratios to allow a significant scattering of proton signals that overlap in neat  $CDCl_3$ .

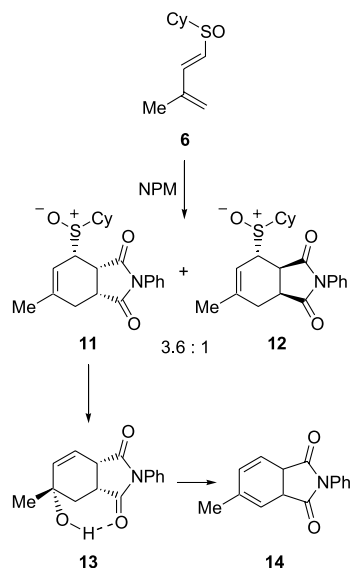
The separation of the cyclohexyl protons H<sub>2</sub>-2'-H<sub>2</sub>-6' from all the other methylene protons and the consequent <sup>1</sup>H and <sup>13</sup>C assignments were performed by TOCSY experiments. The rather different chemical shifts of the cyclohexyl protons in the two adducts **9** and **10** is an interesting consequence of the different configuration of the moiety C(3a)–C(9b)–C(9a), and then of the different anisotropy effect of C(5)–C(5a) double bond. The *cis*-arrangement of H-**3a** and H-**9b** in both cycloadducts **9** and **10** follows from the NOE observed between them, together with  $J_{3a,9b}$  values (8.7, 9.4 Hz for **9** and **10**, respectively). Comparison of  $J_{9a,9b}$  of **9** (5.9 Hz) with the corresponding coupling in **10** (7.3 Hz)

confirms the *cis*-arrangement (*pseudo*-axial/equatorial) of H-**9a** and H-**9b** in **9**, and thus a *trans* stereochemical relationship (*pseudo*-diaxial) of the same protons in **10**. Further support to this stereochemical assignment is given by the NOE observed between H-**9a** and H-**9b**: while for cycloadduct **9** a large NOE was observed between these protons, also NOE between them, although very small, was observed in the case of adduct **10**, coming from the *exo*-approach of NPM to the (*Re*) face of ( $R_S$ )-**7**.

Noteworthy, in both cycloadditions of NPM to 2-cyclohexylsulfinyl dienes **5** and **7** the diene face of dienophile approach was opposite to the one normally observed in the literature but in accordance with the result reported in entry 6 of Table 1. The experimental data can be rationalised by suggesting that, when a tertiary carbon is directly linked to the sulfinyl group of the diene, the dienophile approaches the diene face opposite to the one including the sterically demanding alkyl substituent that arranges itself at about 90° with respect to the diene reactive plane. If the diene skeleton is unsubstituted at C(3) ( $R^3=H$  in Fig. 5), **E** conformation is a reliable alternative to **A** (Figs. 1 and 5), maintaining *transoid* sulfur oxygen to C(1)–C(2) double bond, and directing NPM onto the same (*Si*) face of the ( $pR_S$ )-2-sulfinyl diene. However, if a substituent is



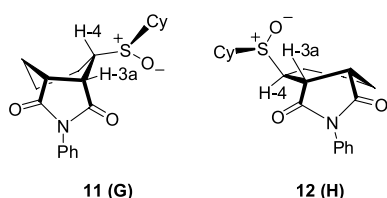
**Figure 5.** Conformational preferences in Diels–Alder transition states of ( $pR_S$ )-2-sulfinyl dienes.



Scheme 3.

present at C(3), as occurs in dienes **5** and **7**, the steric hindrance between sulfinyl oxygen and unsaturated moiety including  $R^3$  affords the dienophile approach from the opposite (*Re*) face, (*pr<sub>S</sub>*)-sulfinyl diene adopting in the transition state the **F** conformation (Fig. 5) that corresponds to **D** in Figure 2.

It has been demonstrated that 1-sulfinyl dienes are much less reactive than 2-sulfinyl dienes, and the reactivity dependence on the position of the sulfinyl group in the diene skeleton has been explained on the basis of the electronic characteristics of the sulfoxide moiety.<sup>9</sup> It was not a surprise when (*E*)-1-cyclohexylsulfinyl-3-methyl-1,3-butadiene (**6**) did not give any significant result in its reaction with NPM at atmospheric pressure: complex mixtures, but no cycloadducts, were detected (Table 2, entry 8). When NPM reacted with **6** under high pressure (entry 9) a 3.6:1 mixture of cycloadducts **11** and **12** was obtained in 60% yield (Scheme 3). The major product of the reaction comes from the *endo*-approach of NPM to the (*Re*) face of (*R<sub>S</sub>*)-sulfinyl diene **6** (C in Fig. 1) as commonly accepted,<sup>3</sup> while the minor cycloadduct was obtained by the *exo*-approach of dienophile to the same face of (*R<sub>S</sub>*)-sulfinyl diene **6**. The <sup>1</sup>H NMR data are in good agreement with these structure assignments if we consider conformational preferences of the cyclohexene ring as half-boat **G** in the *endo*-cycloadduct **11** and half-chair **H** in the *exo*-cycloadduct **12** (Fig. 6). On this basis the chemical shift difference of H-4, geminal to the sulfinyl group, appears



**Figure 6.** Partial stereostructures of (4*S*\*,*R<sub>S</sub>*\*)-4-cyclohexylsulfinyl-3a,4,7,7a-tetrahydro-6-methyl-2-phenyl-1*H*-isoindole-1,3(2*H*)-diones **11** and **12**.

diagnostic in the attribution of stereochemistry to diastereoisomers **11** and **12**. H-4 resonates at lower field in **12** (4.00 ppm) with respect to **11** (3.71 ppm) since in **12** H-4 falls into the deshielding cone of NPM carbonyl function. Furthermore, in both cycloadducts **11** and **12**, H-3a resonates at lower field (3.52 and 3.59 ppm in **11** and **12**, respectively), with respect to H-7a (3.36 and 3.38 ppm in **11** and **12**, respectively), this suggests that the sulfinyl group adopts a rigid disposition with the H-3a in the deshielding zone of the sulfinyl oxygen atom.<sup>3c</sup> When cycloadduct **11** was left standing for 15 days at room temperature in chloroform solution, it evolved into compound **13** as a consequence of the well-known sulfoxide-sulfonate rearrangement of allyl sulfoxides. Spontaneous dehydration of **13** led to known *N*-phenyl-4-methyl-1,2-dihydrophthalimide (**14**) (Scheme 3).<sup>10</sup> The occurrence of these conversions is supported by mass spectrometry and NMR experiments.<sup>†</sup>

### 3. Conclusions

The stereochemical results observed in uncatalyzed cycloadditions of NPM with chiral 2-cyclohexylsulfinyl-1,3-dienes **5** and **7** allowed a deeper insight into the comprehension of the factors that affect the facial diastereoselection in these DA reactions. We have demonstrated the exiguity of the generally accepted assumption that the sulfur configuration is the only controller of the diastereofacial selectivity in DA reactions involving 2-sulfinyl dienes, since (i) the feature of the non-diene group linked to the sulfoxide sulfur, (ii) the steric requirements of the dienophile, (iii) the presence of a 3-substituent on the 2-sulfinyl-1,3-diene skeleton all contribute to the identification of the preferred face of approach by the dienophile. All these factors, together with sulfur configuration, have to be taken into consideration for an accurate foresight of the facial discrimination. In particular, the relevance of the structural characteristics of the non-diene group linked to the sulfoxide sulfur become evident if we compare the reactivity of diene **7** and the one quoted in Table 1, entry 5: these dienes differ only for cyclohexyl or isoborneol substituent at sulfur, and this difference alone exchanges the preferred face of NPM approach. The use of high pressure improved the stereochemical outcome of NPM cycloaddition by 1-[(cyclohexylsulfinyl)ethenyl]cyclohexene (**7**), and allowed DA reaction of the poorly reactive (*E*)-1-cyclohexylsulfinyl-3-methyl-1,3-butadiene (**6**).

<sup>†</sup> (3*aR*\*,5*S*\*,7*aS*\*)-3a,4,5,7a-Tetrahydro-5-hydroxy-5-methyl-2-phenyl-1*H*-isoindole-1,3(2*H*)-dione (**13**). <sup>1</sup>H NMR (400 MHz) δ 7.5–7.2 (m, 5H, H-2'',3'',4'',5'',6''), 6.00 (m, 2H, H-6,7), 3.61 (m, 1H, H-7a), 3.08 (m, 1H, H-3a), 2.40 (m, 1H, H<sub>A</sub>-4), 1.86 (m, 1H, H<sub>B</sub>-4), 1.37 (s, 3H, Me). <sup>13</sup>C NMR (100 MHz) δ 179.0 and 175.8 (C-1,3), 137.1 and 123.7 (C-6,7), 132.1 (C-1''), 129.1 (C-3'',5''), 128.6 (C-4''), 126.5 (C-2'',6''), 67.0 (C-5), 40.6 (C-7a), 37.1 (C-3a), 36.2 (C-4), 29.4 (Me); MS *m/z* (rel. intensity) 257 (M<sup>+</sup>, 23), 242 (6), 214 (3), 138 (21), 93 (base), 77 (14). *N*-Phenyl-4-methyl-1,2-dihydrophthalimide (**14**): MS *m/z* (rel. intensity) 239 (M<sup>+</sup>, 24), 193 (3), 120 (41), 105 (base), 91 (40), 77 (1).

## 4. Experimental

### 4.1. General

Solvents were purified according to standard procedures. Petrol refers to light petroleum, bp 30–40 °C. All reactions were monitored by TLC on commercially available pre-coated plates (Aldrich silica gel 60 F 254) and the products were visualised with vanillin [1 g dissolved in MeOH (60 mL) and conc. H<sub>2</sub>SO<sub>4</sub> (0.6 mL)] and/or I<sub>2</sub>. Column chromatographies were performed on Aldrich 60 and/or Riedel de Haën silica gel (32–63 μm; 230–400 mesh ASTM). Melting points were determined on a Büchi microscopic apparatus and are uncorrected. IR spectra were recorded in CHCl<sub>3</sub> solution on a Perkin-Elmer Paragon 500 FT-IR. <sup>1</sup>H and <sup>13</sup>C NMR spectra were recorded in CDCl<sub>3</sub> solutions (unless otherwise stated) with SiMe<sub>4</sub> as internal standard on Varian Mercury 300 and VXR-400 spectrometers. The NMR attributions are supported by APT, homodecoupling, COSY, <sup>1</sup>H–{<sup>1</sup>H} NOE, HETCOR, and TOCSY experiments. Quaternary carbons were assigned by 2D long-range hetero-correlated experiments. Proton and carbon nuclei, marked with (′), pertain to the cyclohexyl moiety, while (′′) marks vinyl protons in compound **7** and phenyl nuclei in compounds **8–13**. Mass spectra were measured by a Hewlett Packard 5970 GC–MS instrument. All chiral compounds are racemic mixtures. Cycloadditions under pressure were realised using an UNIPRESS-EQUIPMENT liquid piston vessel LV 30/16.

*X-ray crystallography.* All measurements were carried out with a Goniometer Oxford Diffraction KM4 Xcalibur2 at room temperature. Graphite-monochromated Cu Kα radiation (40 mA/–40 kV) and a KM4 CCD/SAPPHIRE detector were used for cell parameter determination and data collection. The integrated intensities, measured using the ω scan mode, were corrected for Lorentz and polarisation effects.<sup>11</sup> The substantial redundancy in data allows empirical absorption corrections (SADABS<sup>12</sup>) to be applied using multiple measurements of symmetry-equivalent reflections. The structures were solved by direct methods of SIR97<sup>13</sup> and refined using the full-matrix least squares on *F*<sup>2</sup> provided by SHELXL97.<sup>14</sup> The non-hydrogen atoms were refined anisotropically, whereas hydrogen atoms were refined as isotropic. Aromatic and cyclohexyl hydrogens were assigned in calculated positions, the others were found in the Fourier difference synthesis.

Crystallographic data (excluding structure factors) for the structures in this paper have been deposited with the Cambridge Crystallographic Data Centre as supplementary publication numbers CCDC 264418 (adduct **8**) and 264419 (adduct **9**). Copies of the data can be obtained, free of charge, on application to CCDC, 12 Union Road, Cambridge CB2 1EZ UK (fax: +44 1223 336033 or e-mail: [deposit@ccdc.cam.ac.uk](mailto:deposit@ccdc.cam.ac.uk)).

**4.1.1. 3-Cyclohexylthiopropenenitrile (2).**<sup>7</sup> Acrylonitrile (0.79 mL, 12.0 mmol) was added slowly to a solution (anhydrous THF, 45 mL) of cyclohexanethiol (1.22 mL, 10.0 mmol) and Triton B (0.54 mL, 40 wt% solution in MeOH, 1.2 mmol) at –78 °C. The reaction mixture was allowed to reach spontaneously the room temperature, and

water (80 mL) was added. The crude product was extracted with Et<sub>2</sub>O (4 × 80 mL). The combined organic layers were washed with saturated NaCl solution (3 × 50 mL) and dried (Na<sub>2</sub>SO<sub>4</sub>). Evaporation of the solvent gave an oily residue that was purified by column chromatography eluting with petrol/EtOAc 4:1. Sulfide **2** (1.52 g, 9.0 mmol, 90% yield) was isolated as an oil. <sup>1</sup>H NMR (300 MHz) δ 2.81 (split t, 2H, *J*<sub>vic</sub> = 7.3 Hz, H<sub>2</sub>-3), 2.73 (m, 1H, H-1′), 2.62 (split t, 2H, H<sub>2</sub>-2), 2.0–1.2 (m, 10H, H<sub>2</sub>-2′,3′,4′,5′,6′). Anal. Calcd for C<sub>9</sub>H<sub>15</sub>NS: C, 63.85; H, 8.93. Found: C, 63.93; H, 9.06.

**4.1.2. 3-Cyclohexylsulfinylpropanenitrile (3).** *m*-CPBA (3.82 g 80%, 17.7 mmol) was dissolved in CH<sub>2</sub>Cl<sub>2</sub> (50 mL) freshly distilled and added dropwise to a solution of sulfide **2** (3.00 g, 17.7 mmol) in CH<sub>2</sub>Cl<sub>2</sub> (50 mL) at –40 °C. When the reaction appeared complete by TLC (30 min) a 10% solution of Na<sub>2</sub>S<sub>2</sub>O<sub>3</sub> was added (50 mL) and the organic layer was extracted and washed with a saturated solution of NaHCO<sub>3</sub> (3 × 60 mL, until the neutrality was reached) and water (2 × 80 mL). Evaporation of the solvent under reduced pressure gave sulfoxide **3** as an oil not needing of purification (quantitative yield). <sup>1</sup>H NMR (300 MHz) δ 3.0–2.8 (m, 4H, H<sub>2</sub>-2,3), 2.67 (tt, 1H, *J*<sub>vic</sub> = 11.2, 3.5 Hz, H-1′), 2.2–1.2 (m, 10H, H<sub>2</sub>-2′,3′,4′,5′,6′). Anal. Calcd for C<sub>9</sub>H<sub>15</sub>NOS: C, 58.34; H, 8.16. Found: C, 58.22; H, 8.40.

**4.1.3. Cyclohexylsulfinyl-3-methyl-1,3-butadienes 5 and 6.** A solution of sulfoxide **3** (3.00 g, 16.2 mmol) and 2-methyl-1-buten-3-yne (15.4 mL, 162.0 mmol) in toluene (25 mL) was maintained at 95 °C. When the reaction appeared complete by TLC (7 h) the solvent was removed under reduced pressure. Column chromatography (petrol/EtOAc 9:1) of the crude product mixture afforded 2-cyclohexylsulfinyl-3-methyl-1,3-butadiene (**5**) as first eluted oil (1.41 g, 7.1 mmol, 44% yield). <sup>1</sup>H NMR (300 MHz) δ 5.88 (s, 1H, H<sub>A</sub>-1), 5.87 (s, 1H, H<sub>B</sub>-1), 5.16 (s, 1H, H<sub>A</sub>-4), 5.14 (s, 1H, H<sub>B</sub>-4), 2.56 (tt, 1H, *J*<sub>vic</sub> = 12.0, 3.7 Hz, H-1′), 2.00 (s, 3H, Me), 1.9–1.1 (m, 10H, H<sub>2</sub>-2′,3′,4′,5′,6′). Anal. Calcd for C<sub>11</sub>H<sub>18</sub>OS: C, 66.62; H, 9.15. Found: C, 66.61; H, 9.18. Then the minor product (*E*)-1-cyclohexylsulfinyl-3-methyl-1,3-butadiene (**6**) (0.20 g, 1.0 mmol, 6% yield) was eluted as an oil. <sup>1</sup>H NMR (300 MHz) δ 6.92 (AB d, 1H, *J*<sub>1,2</sub> = 15.4 Hz, H-2), 6.27 (AB d, 1H, H-1), 5.28 (br s, 2H, H<sub>2</sub>-4), 2.64 (tt, 1H, *J*<sub>vic</sub> = 11.4, 3.5 Hz, H-1′), 2.2–1.1 (m, 10H, H<sub>2</sub>-2′,3′,4′,5′,6′), 1.92 (s, 3H, Me). Anal. Calcd for C<sub>11</sub>H<sub>18</sub>OS: C, 66.62; H, 9.15. Found: C, 66.50; H, 8.99.

**4.1.4. 1-[1-(Cyclohexylsulfinyl)ethenyl]cyclohexene (7).** A solution of sulfoxide **3** (2.00 g, 10.8 mmol) in neat 1-ethynylcyclohexene (8 mL, 67.4 mmol) was maintained at 130 °C. When the reaction appeared complete by TLC (30 min) the crude mixture was purified by column chromatography eluting with petrol/EtOAc 9:1. Diene **7** was isolated as an oil (1.29 g, 5.4 mmol, 50% yield). <sup>1</sup>H NMR (300 MHz) δ 5.95 (br t, 1H, *J*<sub>2,3</sub> = 4.0 Hz, H-2), 5.73 (s, 1H, H<sub>A</sub>-2′′), 5.72 (s, 1H, H<sub>B</sub>-2′′), 2.51 (tt, 1H, *J*<sub>vic</sub> = 12.0, 3.7 Hz, H-1′), 2.4–1.1 (m, 18H, H<sub>2</sub>-2′,3′,3′,4′,4′,5′,5′,6′,6′). Anal. Calcd for C<sub>14</sub>H<sub>22</sub>OS: C, 70.54; H, 9.30. Found: C, 70.69; H, 9.47.

## 4.2. General procedure for the Diels–Alder reactions of sulfinyl dienes 5–7 with NPM

As reported in Table 2, the cycloadditions were accomplished at atmospheric pressure (entries 1, 3, 5, and 8) and under high pressure conditions (entries 2, 4, 6, 7, and 9). For the experiments performed at atmospheric pressure, a solution of the diene (1.5 mmol) in the quoted solvent (5 mL) was added to NPM dissolved in the same solvent (10 mL). The resulting solution was maintained at the indicated temperature, then cooled and the solvent evaporated under vacuum. For the experiments performed at high pressure, a solution of diene (1.5 mmol) and dienophile in the quoted solvent (12 mL) was placed into a 15 mL Teflon vial and solvent was added until the vial was completely filled. The vial was closed and kept at 8 kbar at the indicated temperature. After depressurising, the solvent was removed in vacuo. Each crude mixture obtained (all entries in Table 2) was purified by column chromatography on silica gel eluting with EtOAc/hexane 4:1.

**4.2.1. (3aS\*,7aR\*,R<sub>S</sub>\*)-5-Cyclohexylsulfinyl-3a,4,7,7a-tetrahydro-6-methyl-2-phenyl-1H-isoindole-1,3(2H)-dione (8).** Pale yellow crystals, mp 162–163 °C (EtOAc), IR  $\nu_{\max}$  1713 (C=O)  $\text{cm}^{-1}$ . <sup>1</sup>H NMR (400 MHz)  $\delta$  7.42 (m, 2H, H-3'',5''), 7.34 (m, 1H, H-4''), 7.28 (m, 2H, H-2'',6''), 3.37 (ddd, 1H,  $J_{3a,4A}=2.4$  Hz,  $J_{3a,4B}=7.1$  Hz,  $J_{3a,7a}=9.0$  Hz, H-3a), 3.34 (ddd, 1H,  $J_{7a,7A}=2.9$  Hz,  $J_{7a,7B}=6.0$  Hz, H-7a), 3.26 (dd, 1H,  $J_{4A,4B}=15.2$  Hz, H<sub>A</sub>-4) 2.82 (dd, 1H,  $J_{7A,7B}=15.2$  Hz, H<sub>A</sub>-7), 2.61 (tt, 1H,  $J_{vic}=10.8$ , 3.8 Hz, H-1'), 2.47 (dd, H<sub>B</sub>-7), 2.36 (dd, 1H, H<sub>B</sub>-4), 2.16 (m, 1H, H<sub>A</sub>-6'), 2.04 (br s, 3H, Me), 1.89 (m, 1H, H<sub>A</sub>-3'), 1.79 (m, 1H, H<sub>A</sub>-2'), 1.68 (m, 1H, H<sub>A</sub>-5'), 1.57 (m, 1H, H<sub>A</sub>-4'), 1.47 (m, 1H, H<sub>B</sub>-6'), 1.28 (m, 2H, H<sub>B</sub>-2',4'), 1.25 (m, 1H, H<sub>B</sub>-3'), 1.22 (m, 1H, H<sub>B</sub>-5'). <sup>13</sup>C NMR (100 MHz)  $\delta$  177.9 and 177.3 (C-1,3), 145.2 (C-6), 133.7 (C-5), 132.0 (C-1''), 129.3 (C-3'',5''), 128.8 (C-4''), 126.7 (C-2'',6''), 59.1 (C-1'), 39.9 (C-7a), 39.8 (C-3a), 31.9 (C-7), 26.6 (C-6'), 26.2 (C-2'), 25.8, 25.5, and 25.2 (C-3',4',5'), 20.8 (Me), 20.5 (C-4). Anal. Calcd for C<sub>21</sub>H<sub>25</sub>NO<sub>3</sub>S: C, 67.89; H, 6.78. Found: C, 67.80; H, 6.81.

X-ray structural analysis of **8**: formula C<sub>21</sub>H<sub>25</sub>NO<sub>3</sub>S,  $M=371.48$ , monoclinic, space group  $P2_1/c$ ,  $a=11.399(7)$  Å,  $b=10.761(8)$  Å,  $c=16.815(10)$  Å,  $\beta=107.43(5)^\circ$ ,  $V=1968(2)$  Å<sup>3</sup>,  $Z=4$ ,  $D_c=1.254$ ,  $\mu=1.618$  mm<sup>-1</sup>,  $F(000)=792$ . 5223 Reflections were collected in a  $13.28 < \theta < 58.93$  range with a completeness to  $\theta$  92.7%; 2616 were independent, the parameters were 264, and the final  $R$  index was 0.0506 for reflections having  $I > 2\sigma I$ , and 0.0549 for all data.

**4.2.2. (3aS\*,9aS\*,9bR\*,R<sub>S</sub>\*)-5-Cyclohexylsulfinyl-3a,4,6,7,8,9,9a,9b-octahydro-2-phenyl-1H-benz[e]isoindole-1,3(2H)-dione (9).** Pale yellow crystals, mp 202–203 °C (EtOAc), IR  $\nu_{\max}$  1713 (C=O)  $\text{cm}^{-1}$ . <sup>1</sup>H NMR (400 MHz, CDCl<sub>3</sub>/C<sub>6</sub>D<sub>6</sub> 1:1)  $\delta$  7.37 (m, 2H, H-3'',5''), 7.27 (m, 1H, H-4''), 7.26 (m, 2H, H-2'',6''), 3.28 (dd, 1H,  $J_{3a,4A}=2.4$  Hz,  $J_{4A,4B}=15.8$  Hz, H<sub>A</sub>-4), 3.17 (ddd, 1H,  $J_{3a,4B}=8.1$  Hz,  $J_{3a,9b}=8.7$  Hz, H-3a), 3.07 (dd, 1H,  $J_{9a,9b}=5.9$  Hz, H-9b), 2.54 (tt, 1H,  $J_{vic}=10.8$ , 3.7 Hz, H-1'), 2.50 (m, 1H, H<sub>A</sub>-6), 2.39 (ddd, 1H,  $J_{8,9a}=11.0$ , 6.2 Hz, H-9a), 2.30 (m, 1H, H<sub>B</sub>-6), 2.24 (m, 1H, H<sub>A</sub>-9), 2.18 (dd, H<sub>B</sub>-4), 2.17 (m,

1H, H<sub>A</sub>-2'), 1.85 (m, 1H, H<sub>A</sub>-5'), 1.84 (m, 1H, H<sub>A</sub>-7), 1.83 (m, 1H, H<sub>B</sub>-9), 1.70 (m, 1H, H<sub>A</sub>-3'), 1.62 (m, 1H, H<sub>A</sub>-4'), 1.60 (m, 1H, H<sub>A</sub>-8), 1.51 (m, 1H, H<sub>A</sub>-6'), 1.46 (m, 1H, H<sub>B</sub>-7), 1.45 (m, 1H, H<sub>B</sub>-2'), 1.29 (m, 1H, H<sub>B</sub>-8), 1.23 (m, 1H, H<sub>B</sub>-4'), 1.21 (m, 1H, H<sub>B</sub>-5'), 1.19 (m, 1H, H<sub>B</sub>-3'), 1.17 (m, 1H, H<sub>B</sub>-6'). <sup>13</sup>C NMR (100 MHz, CDCl<sub>3</sub>/C<sub>6</sub>D<sub>6</sub> 1:1)  $\delta$  177.0 (C-3), 176.6 (C-1), 150.9 (C-5a), 132.0 (C-1''), 130.8 (C-5), 128.9 (C-3'',5''), 128.5 (C-4''), 126.0 (C-2'',6''), 58.7 (C-1'), 43.3 (C-9b), 39.8 (C-3a), 39.2 (C-9a), 27.2 (C-6), 26.5 (C-2'), 26.0, 25.7, 25.4, and 25.1 (C-3',4',5',6'), 25.2 (C-9), 22.6 (C-8), 22.2 (C-7), 20.0 (C-4). Anal. Calcd for C<sub>24</sub>H<sub>29</sub>NO<sub>3</sub>S: C, 70.04; H, 7.10. Found: C, 70.12; H, 6.98.

X-ray structural analysis of **9**: formula C<sub>24</sub>H<sub>29</sub>NO<sub>3</sub>S,  $M=411.54$ , orthorhombic, space group  $Pcab$ ,  $a=12.427(1)$  Å,  $b=16.259(1)$  Å,  $c=21.454(1)$  Å,  $V=4334.8(5)$  Å<sup>3</sup>,  $Z=8$ ,  $D_c=1.261$ ,  $\mu=1.519$  mm<sup>-1</sup>,  $F(000)=1760$ . 10429 reflections were collected in a  $4.93 < \theta < 59.05$  range with a completeness to  $\theta$  95.8%; 2985 were independent, the parameters were 274, and the final  $R$  index was 0.0505 for reflections having  $I > 2\sigma I$ , and 0.0632 for all data.

**4.2.3. (3aR\*,9aS\*,9bS\*,R<sub>S</sub>\*)-5-Cyclohexylsulfinyl-3a,4,6,7,8,9,9a,9b-octahydro-2-phenyl-1H-benz[e]isoindole-1,3(2H)-dione (10).** Pale yellow crystals, mp 182–183 °C (EtOAc), IR  $\nu_{\max}$  1712 (C=O)  $\text{cm}^{-1}$ . <sup>1</sup>H NMR (400 MHz, CDCl<sub>3</sub>/C<sub>6</sub>D<sub>6</sub> 1:1)  $\delta$  7.35 (m, 2H, H-3'',5''), 7.24 (m, 1H, H-4''), 7.22 (m, 2H, H-2'',6''), 3.22 (dd, 1H,  $J_{3a,4A}=1.9$  Hz,  $J_{4A,4B}=16.4$  Hz, H-4), 3.07 (ddd, 1H,  $J_{3a,4B}=7.3$  Hz,  $J_{3a,9b}=9.4$  Hz, H-3a), 2.92 (dd, 1H,  $J_{9a,9b}=7.3$  Hz, H-9b), 2.63 (tt, 1H,  $J_{vic}=10.8$ , 3.6 Hz, H-1'), 2.58 (ddd, 1H,  $J_{6A,6B}=15.4$  Hz,  $J_{6A,7}=4.4$ , 3.5 Hz, H<sub>A</sub>-6), 2.32 (ddd, 1H,  $J_{9,9a}=13.4$ , 4.6 Hz, H-9a), 2.30 (dd, 1H, H<sub>B</sub>-4), 2.20 (m, 1H, H<sub>A</sub>-2'), 2.14 (m, 1H, H<sub>B</sub>-6), 2.02 (m, 1H, H<sub>A</sub>-9), 1.80 (m, 1H, H<sub>B</sub>-9), 1.78 (m, 1H, H<sub>A</sub>-8), 1.74 (m, 1H, H<sub>A</sub>-3'), 1.6–1.5 (m, 2H, H<sub>2</sub>-7), 1.38 (m, 1H, H<sub>A</sub>-4'), 1.34 (m, 1H, H<sub>B</sub>-2'), 1.30 (m, 1H, H<sub>B</sub>-8), 1.20 (m, 1H, H<sub>B</sub>-3'), 1.17 (m, 1H, H<sub>A</sub>-5'), 1.03 (m, 2H, H<sub>B</sub>-4', H<sub>A</sub>-6'), 0.88 (m, 1H, H<sub>B</sub>-6'), 0.77 (m, 1H, H<sub>B</sub>-5'). <sup>13</sup>C NMR (100 MHz, CDCl<sub>3</sub>/C<sub>6</sub>D<sub>6</sub> 1:1)  $\delta$  177.5 (C-3), 175.9 (C-1), 150.4 (C-5a), 132.1 (C-1''), 131.9 (C-5), 128.9 (C-3'',5''), 128.2 (C-4''), 126.0 (C-2'',6''), 57.3 (C-1'), 43.1 (C-9b), 39.8 (C-3a), 39.5 (C-9a), 26.7 (C-2'), 26.3 (C-6), 25.9 (C-6'), 25.5 (C-4'), 24.8 (C-3'), 24.5 (C-5',9), 21.7 (C-8), 21.2 (C-7), 20.5 (C-4). Anal. Calcd for C<sub>24</sub>H<sub>29</sub>NO<sub>3</sub>S: C, 70.04; H, 7.10. Found: C, 69.98; H, 7.15.

**4.2.4. (3aS\*,4S\*,7aR\*,R<sub>S</sub>\*)-4-Cyclohexylsulfinyl-3a,4,7,7a-tetrahydro-6-methyl-2-phenyl-1H-isoindole-1,3(2H)-dione (11).** Low melting solid, IR  $\nu_{\max}$  1712 (C=O)  $\text{cm}^{-1}$ . <sup>1</sup>H NMR (400 MHz)  $\delta$  7.5–7.3 (m, 5H, H-2'',3'',4'',5'',6''), 5.69 (m, 1H, H-5), 3.71 (dd, 1H,  $J_{3a,4}=7.0$  Hz,  $J_{4,5}=6.4$  Hz, H-4), 3.52 (dd, 1H,  $J_{3a,7a}=9.6$  Hz, H-3a), 3.36 (dt, 1H,  $J_{3a,7a}=J_{7a,7B}=9.6$  Hz,  $J_{7a,7A}=5.7$  Hz, H-7a), 2.9–2.8 (m, 2H, H-1', H<sub>A</sub>-7), 2.38 (dd, 1H,  $J_{7A,7B}=16.8$  Hz, H<sub>B</sub>-7), 2.0–1.2 (m, 10H, H<sub>2</sub>-2',3',4',5',6'), 1.96 (s, 3H, Me). <sup>13</sup>C NMR (100 MHz)  $\delta$  177.6 and 175.8 (C-1,3), 144.3 (C-6), 131.7 (C-1''), 129.1 (C-3'',5''), 128.5 (C-4''), 126.6 (C-2'',6''), 112.6 (C-5), 56.5 (C-1'), 52.4 (C-4), 41.4 (C-3a), 38.4 (C-7a), 28.5 (C-7), 26.4, 25.5, 25.2, 25.0, and 24.6 (C-2',3',4',5',6'), 24.2 (Me). Anal. Calcd for C<sub>21</sub>H<sub>25</sub>NO<sub>3</sub>S: C, 67.89; H, 6.78. Found: C, 67.77; H, 6.84.

**4.2.5. (3aR\*,4S\*,7aS\*,R<sub>S</sub>\*)-4-Cyclohexylsulfinyl-3a,4,7,7a-tetrahydro-6-methyl-2-phenyl-1H-isoindole-1,3(2H)-dione (12).** Low melting solid, IR  $\nu_{\max}$  1712 (C=O)  $\text{cm}^{-1}$ .  $^1\text{H}$  NMR (400 MHz)  $\delta$  7.5–7.4 (m, 5H, H-2'',3'',4'',5'',6''), 5.53 (m, 1H, H-5), 4.00 (dd, 1H,  $J_{3a,4}$  = 5.4 Hz,  $J_{4,5}$  = 5.5 Hz, H-4), 3.59 (dd, 1H,  $J_{3a,7a}$  = 9.5 Hz, H-3a), 3.38 (ddd, 1H,  $J_{7a,7A}$  = 6.2 Hz,  $J_{7a,7B}$  = 9.3 Hz, H-7a), 2.8–2.7 (m, 2H, H-1', H<sub>A</sub>-7), 2.54 (dd, 1H,  $J_{7A,7B}$  = 16.5 Hz, H<sub>B</sub>-7), 2.0–1.2 (m, 10H, H<sub>2</sub>-2',3',4',5',6'), 1.90 (s, 3H, Me).  $^{13}\text{C}$  NMR (100 MHz)  $\delta$  178.8 and 175.8 (C-1,3), 143.4 (C-6), 132.9 (C-1''), 129.9 (C-3'',5''), 129.3 (C-4''), 127.5 (C-2'',6''), 117.0 (C-5), 58.0 (C-1'), 55.9 (C-4), 42.4 (C-3a), 39.8 (C-7a), 29.5 (C-7), 28.6, 26.7, 26.3, 26.1, and 23.2 (C-2',3',4',5',6'), 24.6 (Me). Anal. Calcd for C<sub>21</sub>H<sub>25</sub>NO<sub>3</sub>S: C, 67.89; H, 6.78. Found: C, 67.95; H, 6.80.

### Acknowledgements

This work was carried out under the auspices of the national projects 'Stereoselezione in sintesi organica, metodologie ed applicazioni' and supported by MIUR (Ministero dell'Istruzione, dell'Università e della Ricerca) Rome, Italy. The work was also supported by the University of Messina.

### References and notes

- For reviews: Aversa, M. C.; Barattucci, A.; Bonaccorsi, P.; Giannetto, P. *Tetrahedron: Asymmetry* **1997**, *8*, 1339–1367. *Arkivoc* **2002**, 79–98. García Ruano, J. L.; Cid de la Plata, B. *Top. Curr. Chem.* **1999**, *204*, 1–126. Hanquet, G.; Colobert, F.; Lanners, S.; Solladié, G. *Arkivoc* **2003**, 328–401.
- (a) Gosselin, P.; Bonfand, E.; Hayes, P.; Retoux, R.; Maignan, C. *Tetrahedron: Asymmetry* **1994**, *5*, 781–784. (b) Yang, T.-K.; Chu, H.-Y.; Lee, D.-S.; Jiang, Y.-Z.; Chou, T.-S. *Tetrahedron Lett.* **1996**, *37*, 4537–4540. (c) Aversa, M. C.; Barattucci, A.; Bonaccorsi, P.; Giannetto, P.; Panzalorto, M.; Rizzo, S. *Tetrahedron: Asymmetry* **1998**, *9*, 1577–1587. (d) Aversa, M. C.; Barattucci, A.; Bonaccorsi, P.; Giannetto, P.; Nicolò, F. *J. Org. Chem.* **1999**, *64*, 2114–2118. (e) Aversa, M. C.; Barattucci, A.; Bonaccorsi, P.; Bruno, G.; Giannetto, P.; Policicchio, M. *Tetrahedron Lett.* **2000**, *41*, 4441–4445. (f) Chou, S.-S. P.; Liang, P.-W. *Tetrahedron Lett.* **2002**, *43*, 4865–4870.
- (a) Fisher, M. J.; Hehre, W. J.; Kahn, S. D.; Overman, L. E. *J. Am. Chem. Soc.* **1988**, *110*, 4625–4633. (b) Fisher, M. J.; Overman, L. E. *J. Org. Chem.* **1988**, *53*, 2630–2634. (c) Arce, E.; Carreño, M. C.; Cid, M. B.; García Ruano, J. L. *J. Org. Chem.* **1994**, *59*, 3421–3426. (d) Carreño, M. C.; Cid, M. B.; García Ruano, J. L. *Tetrahedron: Asymmetry* **1996**, *7*, 2151–2158. (e) Blasco, S.; Carreño, M. C.; Cid, M. B.; García Ruano, J. L.; Martín, M. R. *Tetrahedron: Asymmetry* **1999**, *10*, 3473–3477. (f) Bell, A. S.; Fishwick, C. W. G.; Reed, J. E. *Tetrahedron* **1999**, *55*, 12313–12330.
- Aversa, M. C.; Barattucci, A.; Bonaccorsi, P.; Bruno, G.; Caruso, F.; Giannetto, P. *Tetrahedron: Asymmetry* **2001**, *12*, 2901–2908.
- Aversa, M. C.; Barattucci, A.; Bonaccorsi, P.; Bonini, B. F.; Giannetto, P.; Nicolò, F. *Tetrahedron: Asymmetry* **1999**, *10*, 3919–3929.
- Aben, R. W. M.; Minuti, L.; Scheeren, H. W.; Taticchi, A. *Tetrahedron Lett.* **1991**, *32*, 6445–6448. Fringuelli, F.; Minuti, L.; Pizzo, F.; Taticchi, A. *Acta Chem. Scand.* **1993**, *47*, 255–263. Minuti, L.; Taticchi, A. In *Seminars in Organic Synthesis*; Trombini, C., Ed. Multiple and High Pressure Diels–Alder Reactions. Minuti, L.; Taticchi, A.; Costantini, L. *Recent Res. Dev. Org. Chem.* **1999**, *3*, 105–116.
- Choudary, B. M.; Lakshmi Kantam, M.; Kavita, B. *Green Chem.* **1999**, *1*, 289–292.
- Aversa, M. C.; Barattucci, A.; Bonaccorsi, P.; Giannetto, P.; Jones, D. N. *J. Org. Chem.* **1997**, *62*, 4376–4384.
- Carreño, M. C.; Cid, M. B.; García Ruano, J. L.; Santos, M. *Tetrahedron: Asymmetry* **1997**, *8*, 2093–2097.
- Jankowski, S.; Quin, L. D. *J. Am. Chem. Soc.* **1991**, *113*, 7011–7017 and references therein.
- Walker, N.; Stuart, D. *Acta Crystallogr. Sect. A* **1983**, *39*, 158–166.
- Sheldrick, G. M. *SADABS version 2.03: A Program for Empirical Absorption Correction*; University of Göttingen: Germany, 1997–2001.
- Altomare, A.; Burla, M. C.; Camalli, M.; Cascarano, G. L.; Giacovazzo, C.; Guagliardi, A.; Moliterni, A. G. G.; Polidori, G.; Spagna, R. *J. Appl. Crystallogr.* **1999**, *32*, 115–119.
- Sheldrick, G. M. *SHELXL97: Program for Crystal Structure Refinement*; University of Göttingen: Germany, 1993.

## Selective synthesis of 14 $\beta$ -amino taxanes

Arturo Battaglia,<sup>a,\*</sup> Eleonora Baldelli,<sup>a,\*</sup> Ezio Bombardelli,<sup>b</sup> Giacomo Carenzi,<sup>c</sup>  
Gabriele Fontana,<sup>b</sup> Maria Luisa Gelmi,<sup>c</sup> Andrea Guerrini<sup>a</sup> and Donato Pocar<sup>c</sup>

<sup>a</sup>Istituto CNR per la Sintesi Organica e Fotoreattività "I.S.O.F.", Area della Ricerca di Bologna, via P. Gobetti 101, 40129 Bologna, Italy

<sup>b</sup>Indena SPA, viale Ortles 12, 20139 Milano, Italy

<sup>c</sup>Istituto di Chimica Organica "A. Marchesini", Facoltà di Farmacia, via Venezian 21, Università di Milano, 20133 Milano, Italy

Received 16 March 2005; revised 11 May 2005; accepted 26 May 2005

Available online 16 June 2005

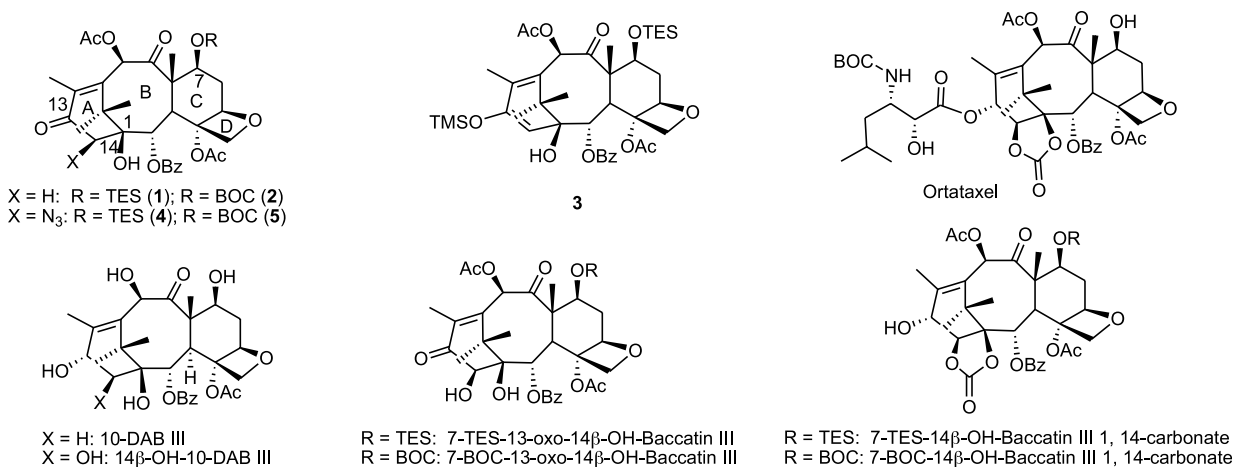
Dedicated to Professor J. Ojima on the occasion of his 60th birthday

**Abstract**—The base induced deprotonation of H-14 of 7-triethylsilyl- (7-TES-) and 7-*tert*-butoxycarbonyl- (7-BOC-) protected 13-oxo-baccatins gave the corresponding enolates, which were selectively aminated with electrophilic nitrogen donors, such as azodicarboxylates and tosyl azide. In particular, tosyl azide gave the corresponding 7-BOC- and 7-TES-13-oxo-14 $\beta$ -azido-baccatin III. Alternatively, the last compound was prepared via NaN<sub>3</sub> induced azidation of the 13-silyl enol ether of 7-TES-13-oxo-baccatin III under oxidative (cerium ammonium nitrate) conditions. The 13-silyl enol ether was obtained in a multistep process by DBU induced silylation of 7-TES-13-oxo-baccatin III. The 7-TES-13-oxo-14 $\beta$ -azido-baccatin III was used as a key intermediate for the synthesis of a new family of antitumour taxanes containing amino based functional groups at the C-14 position, such as: 14 $\beta$ -azido, 14 $\beta$ -amino, 14 $\beta$ -amino 1, 14-carbamate, 14 $\beta$ -amino 1, 14-thiocarbamate, and 14 $\beta$ -amino *N*-*tert*-butoxycarbonyl-1,14-carbamate.  
© 2005 Elsevier Ltd. All rights reserved.

### 1. Introduction

7-TES-13-oxo-baccatin III (**1**, Fig. 1)<sup>1</sup> is an intermediate of choice for studies on taxane chemistry, being used for the synthesis of 12, 13-dihydro-10-DAB III,<sup>2</sup> the 13-*epi*-7-TES-

baccatin III,<sup>3</sup> the enol ester 12, 13-isobaccatin III,<sup>4</sup> and their 12, 13-isotaxanes analogues.<sup>5</sup> In addition, the 13-oxo group activates the functionalization of the C-14 atom via enolate chemistry. For example, the base induced hydroxylation with oxaziridines of the potassium enolate of **1** and its



**Figure 1.** Baccatin III derivatives and Ortataxel.

**Keywords:** 14 $\beta$ -Amino taxanes; 10-DAB III; Silyl enol ethers; Electrophilic amination; 13-Oxo-baccatins.

\* Corresponding authors. Tel.: +39 051 6398311; fax: +39 051 6398349; e-mail: battaglia@isof.cnr.it

7-BOC analogue **2** gave 7-TES- and 7-BOC-13-oxo-14 $\beta$ -OH-baccatin III (Fig. 1).<sup>6</sup> The enolate of **1** was employed for the synthesis of the 13-OTMS enol ether **3**, which was converted into 7-TES-13-oxo-14 $\beta$ -OH-baccatin III by *m*CPBA oxidation.<sup>7</sup> A part from these results, the enolate chemistry was no longer explored since 13-oxobaccatins display a remarkable tendency to skeleton rearrangements when treated with bases such as NaH, pyridine, and DBU.<sup>8a–d</sup> Even so, the inherent potentiality of this chemistry opens new perspectives for innovative functionalizations of the C-14 position. For example, we performed the reduction of the 13-oxo group of 7-TES- and 7-BOC-13-oxo-14 $\beta$ -OH-baccatin III **1**, 14-carbonate to afford the corresponding 14 $\beta$ -OH-baccatin III derivatives (Fig. 1), which are suitable intermediates of potent anticancer taxanes bearing 1,14 carbonate as masked 14 $\beta$ -OH group. These taxanes, which have been so far synthesized from the natural occurring 14 $\beta$ -OH-10-DAB III, a scarcely available chemical feedstock (Fig. 1),<sup>9</sup> display cytotoxic activity in cell lines, which express multi-drug resistance (MDR). The lead compound, Ortataxel, is now in phase II clinical trial.<sup>10</sup> We envisioned that the ‘enolate chemistry’ could be useful for the synthesis of new antitumor taxanes isosters of 14 $\beta$ -OH carbonates. The main support to this project was the observation that SAR studies have established that changes to the ‘southern hemisphere’, comprising C-14, exert a strong effect on taxol’s activity.<sup>11</sup> Our efforts produced other potent antitumor taxanes, which bear an unsaturated and saturated baccatin[14, 1-*d*]-furan-2-one nucleus via aldol addition of ethyl glyoxylate to the enolate of **1**.<sup>12</sup>

Here, we wish to report our studies on the electrophilic amination of the enolates of 13-oxobaccatins **1** and **2**, and the 13-silyl enol ether **3**, to afford a new class of antitumor taxanes. It is worth noting that the insertion of the nitrogen functionality at the C-14 position can afford two epimers, since the new substituent may be located on the lower face of the baccatin skeleton ( $\alpha$ -face), or the upper  $\beta$ -face. These  $\alpha/\beta$  descriptors are defined observing the molecule with the methyl group at C-8 placed in the ‘northern hemisphere’ and pointing toward the observer.<sup>13</sup> To obtain isosteres of Ortataxel, only  $\beta$ -selective amination procedures, and a selective reduction of the C-13 oxo group to afford 13 $\alpha$ -OH epimers, must be developed since the antitumor activity of the resulting taxane is related to the stereochemistry of the 13 and 14 positions of the precursor 14 $\beta$ -OH-10-DAB III.

## 2. Results and discussion

### 2.1. Amination studies of 13-oxobaccatins **1** and **2**

Our synthesis of the target 14 $\beta$ -amino substituted taxanes starts from the natural synthon 10-DAB III. This economically available reagent can be transformed into suitable 7-protected 13-oxobaccatins III according to standard protocols.<sup>14</sup> Namely, the 7-TES derivative **1** was obtained by sequential silylation and acetylation of the C-7 and C-10 hydroxy groups followed by MnO<sub>2</sub> oxidation of the 13-OH, while the 7-BOC analogue **2** was prepared by ozonolysis of 10-DAB III followed by acetylation and carbonylation of the C-10 and C-7 hydroxy groups. The treatment of **1** and **2** with metallic bases at low temperatures (–78 °C) afforded

relatively stable enolates. Alternatively, base induced silylation affords 13-silyl enol ethers via a multistep process. The selective amination of both the enolates of **1** and **2** (protocol A) and the 13-silyl enol ethers (protocol B) afforded the key intermediates 13-oxo-14 $\beta$ -azido-baccatins **4** and **5** (Fig. 1).

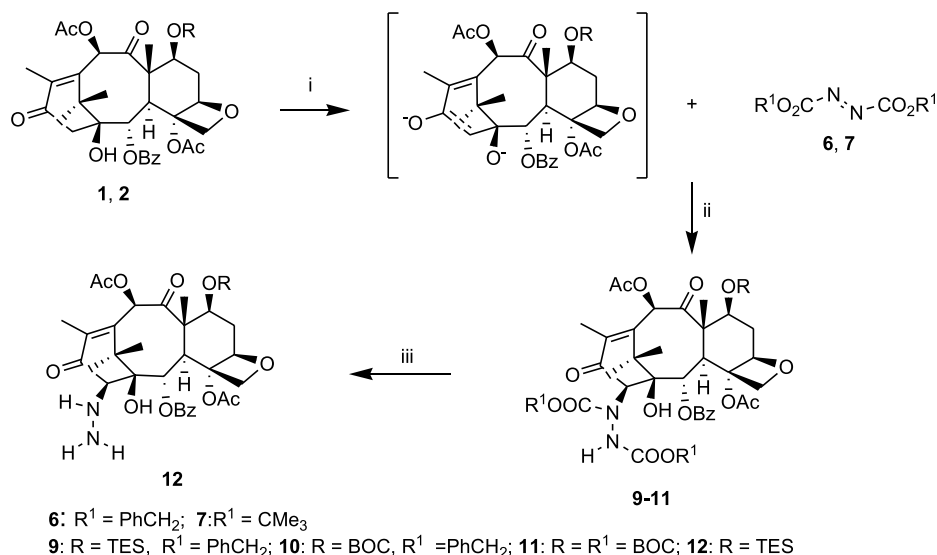
#### 2.1.1. Protocol A. Amination of the enolates of **1** and **2**.

Among the variety of bases available for the synthesis of the enolates of **1** and **2**, potassium *tert*-butoxide (*t*BuOK) in a 4:1 mixed solvent THF/DMPU at –72 °C turned out to be the best one. The enolate is stable for several hours in a range of temperatures (–70/–40 °C) even in the presence of the polar additive DMPU (10–25%). Dibenzyl- and di-*tert*-butyl-azodicarboxylate (**6** and **7**, respectively),<sup>15</sup> and tosyl azide (**8**)<sup>16</sup> were selected as amination reagents.

(i) *Reaction of 1 and 2 with azodicarboxylates.* The amination of enolates **1** and **2** with azodicarboxylates **6** and **7** provided 14-hydrazino baccatins, as possible precursors of the corresponding 14-amino taxanes. In particular, the addition of dibenzyl-azodicarboxylate **6** to the enolates of **1** and **2** afforded the 14-*N,N'*-di(benzyl-oxycarbonyl)-hydrazino derivatives **9** (76%) and **10** (65%), respectively, as single  $\beta$ -epimer (Scheme 1). Similarly, the stereoselective addition of di-*tert*-butyl-azodicarboxylate **7** to the enolate of **2** gave the  $\beta$ -isomer of the *N,N'*-di(*tert*-butyloxycarbonyl)hydrazino derivative **11** in 72% yield. The stereochemistry of the C-14 stereogenic center of compounds **9–11** was assessed by qualitative homonuclear NOE experiments. An enhancement of the H-14 proton (7–9%) upon irradiation of the H-3 proton clearly indicated a  $\beta$ -face selectivity of the reaction. As expected, no effect was observed upon irradiation of the vicinal H-2. Thus, the hydrazino group is placed on the  $\beta$ -face of the taxane skeleton. The chemoselective reduction of the 13-oxo group of compounds **9–11** with sodium or alkyl boron hydrides, according to the methodology developed for the reduction of 13-oxo-14 $\beta$ -OH-baccatins **1**, 14-carbonates,<sup>6</sup> failed.

Next, the conversion of compounds **9–11** into the corresponding 13-oxo-14 $\beta$ -amino baccatins was in vain attempted. In fact, the deprotection of the BOC groups of **11** with formic acid, or TFA in MeOH, yielded several products derived from rearrangements of the taxane skeleton whose structures were no further investigated. Instead, the debenzylation of **9** with 10% Pd/C, followed by one-pot thermal decarbonylation, successfully gave the *N,N'*-unsubstituted hydrazino derivative **12**, which, however, was thermally unstable and rapidly decomposed in solution or in a neat state. In conclusion, all intermediates **9–12** were not workable to achieve our targets.

(ii) *Reaction of 1 and 2 with tosyl azide 8.* It is well known that azides are useful reagents for synthesis of  $\alpha$ -azido ketones.<sup>17</sup> Among the electrophilic azides usually employed for ketone enolates (phenylsulfonyl-, tosyl-, and the encumbered 2,4,6-triisopropylbenzenesulfonyl azide<sup>18</sup>) we selected the less sterically demanding tosyl azide **8**. Since this azide may serve both for diazo or azide transfer reactions,<sup>19</sup> the parameters of the quenching step must be carefully evaluated. The reaction of the enolate of **1** with **8**, performed at –78 °C in a THF/DMPU = 4:1 mixed solvent,



**Scheme 1.** Reagents and conditions: (i) <sup>t</sup>BuOK, 4:1 THF/DMPU, -70 °C; (ii) -50 °C, then saturated NH<sub>4</sub>Cl; (iii) H<sub>2</sub>, 10% Pd/C.

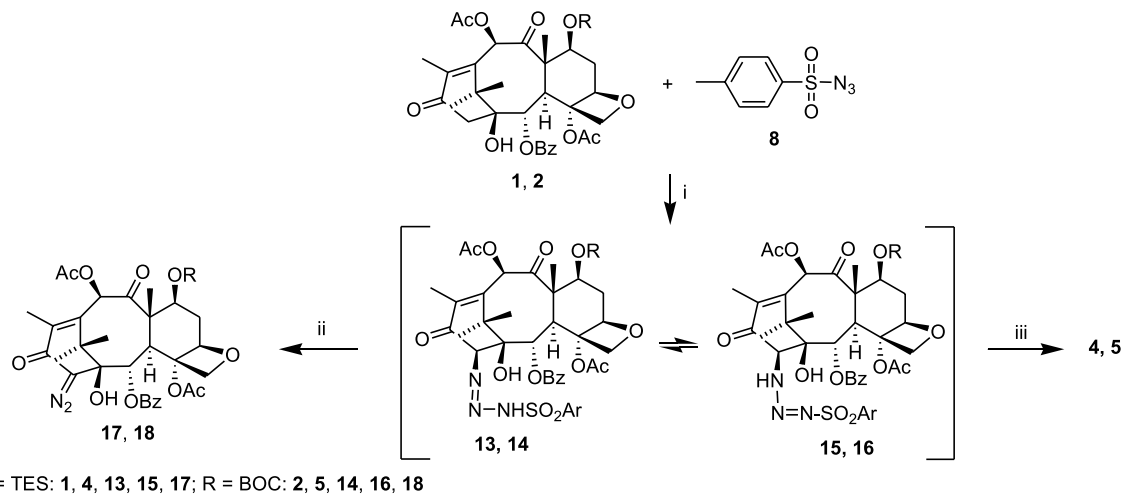
proceeded through transient intermediates, probably a mixture of two tautomeric triazenes **13** and **15**, which quickly converted into products derived from diazo and azide transfer reactions (Scheme 2).<sup>20</sup> For this reason, we attempted to optimize the azido transfer reaction. As soon as the reagent **1** disappeared, the quenching with saturated aqueous NH<sub>4</sub>Cl solution selectively transformed the mixture of **13** and **15** into the 14-azido derivative **4** (92%, Fig. 1) as a single β-epimer. Instead, a clean diazo transfer reaction occurred when the reaction was quenched with an excess of acetic acid, which afforded the 7-TES-13-oxo-14-diazo-baccatin III (**17**) (82% yield). The 7-BOC derivative **2** behaved identically. When the reaction was quenched with NH<sub>4</sub>Cl the triazenes **14** and **16** were transformed into the azido derivative **5** (85%), while quenching with acetic acid yielded the diazo derivative **18** in 72%. The β-stereochemistry of the C-14 stereogenic center of **4** and **5** was assessed by NOE experiments. An enhancement of the H-14 proton (9–11%) was observed upon irradiation of the H-3 proton. The β-selectivity of all amination reactions, similar to that observed in the hydroxylation of these enolates,<sup>6</sup> can be explained by the folded terpenoid

structure, which precludes an approach to the sterically demanding electrophile from the more hindered α-face of the A ring, thus promoting the formation of the 14β epimers.

## 2.2. Silylation of 13-oxobaccatin III (**1**) and amination of the silyl enol ethers under oxidative conditions

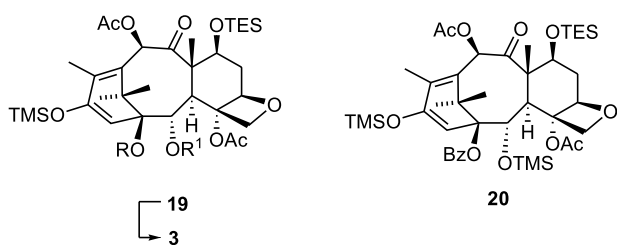
It has been reported that the reaction of **1** with TMSCl and DBU gave a mixture of silylated compounds consisting of the major product **1**, 13-bis-OTMS enol ether **19**, traces of the target 13-OTMS enol ether **3** and the rearranged taxane **20** (Scheme 3). Selective solvolysis of the 1-OTMS group of **19** gave the enol ether **3** in good yield.<sup>7</sup>

Surprisingly, when we repeated the silylation reaction of **1** we obtained a mixture of products different from that reported in the literature. We were unable to explain these differences due to a lack of information about the experimental procedures and analytical data products. For this reason, we have revisited the silylation of **1** employing a variety of silylating agents (TMSCl, TESCl, TIPSCl, and BSA), bases and solvents. From these studies the correct



**Scheme 2.** Reagents and conditions: (i) <sup>t</sup>BuOK, 4:1 THF/DMPU; (ii) CH<sub>3</sub>COOH (**17**, **18**); (iii) NH<sub>4</sub>Cl (**4**, **5**).





3: R = H, R<sup>1</sup> = Bz; 19: R = OTMS, R<sup>1</sup> = Bz;

Scheme 3.

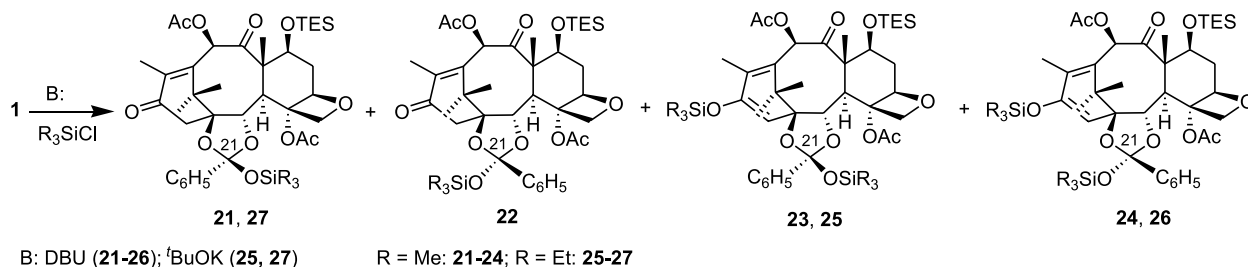
structures of the intermediates involved in these reactions were assessed and the best reaction conditions to selectively obtain 13-silyl enol ethers were found.

**2.2.1. Silylation studies.** (i) *Silylation of 1 with Me<sub>3</sub>SiCl and DBU.* The reaction of **1** (1.0 equiv) with TMSCl (2.5 equiv) and DBU (2.0 equiv) in CH<sub>2</sub>Cl<sub>2</sub> under reflux provided, after a few hours, a complex mixture of 13-oxobaccatins consisting of two *ortho* esters **21** and **22** and minor amounts of their corresponding 13-OTMS enol ethers **23** and **24**, and traces of the 13-OTMS enol ether **3** (Scheme 4).<sup>21</sup> Compounds having a structure consistent with those of the 1-OTMS enol ether **19** and the rearranged taxane **20** were not detected.

The *ortho* esters are formed by DBU induced hydrogen abstraction of 1-OH of **1**. The nucleophilic attack of the resulting 1-oxanion to the carbonyl of the 2-benzoyl group affords an epimeric mixture of cyclic 1,2-benzylidene oxanions (*ortho* esters), which are quenched by the silylating agent. The stereochemical assessments of *ortho* esters **21**, **22**, the 13-enol derivative **3**, and the 13-enol *ortho*

esters **23** and **24** was based on <sup>1</sup>H and <sup>13</sup>C NMR spectroscopic evidences (see Appendix A of Section 4). In particular, we established that the OTMS group of the C-21 carbon atom of the *ortho* ester has β orientation in compounds **21** and **23** and α orientation in compounds **22** and **24**.<sup>13</sup> No significant selectivity was found in the formation of these epimers (see Table 1), while the relative ratio between the 13-oxo *ortho* esters and their 13-OTMS enol ethers depended on the relative 1/TMSCl ratio. Polar solvents, like CH<sub>3</sub>CN, increased the reactivity but did not affect the products distribution. Instead, this distribution was altered by chromatography on silica gel due to a partial desilylation of the *ortho* esters, which reverted to the starting reagent **1** and the silyl enol ether **3** (entry 1). The best conversion of **1** into 13-OTMS *ortho* esters **23** and **24**, valuable precursors of the enol ether **3**, was obtained with a large excess of base and silylating agent according to standard silylation protocols (entry 2).<sup>22</sup> These compounds were quantitatively isolated by chromatography on alumina.

(ii) *Silylation of 1 with TESCl and DBU or <sup>t</sup>BuOK.* The DBU induced silylation of **1** with the more sterically demanding triethylsilyl chloride only occurred in the very polar solvent CH<sub>3</sub>CN and required strong excesses of base and silylating agent. The epimeric pair of 13, 21-bis-OTES *ortho* esters **25** (21 β-OTES) and **26** (21 α-OTES) was obtained in 93% yield (entry 3). A different product distribution was found when we performed the silylation of **1** in the presence of <sup>t</sup>BuOK as the base. The reaction was run at –75 °C with 2.5 equiv of base. Sequential addition of 2.0 equiv of TESCl at this temperature stereoselectively gave the 21β-epimers of 13-oxo-21-OTES *ortho* ester **27**, as the major product (80%, entry 4), and its 13, 21-bis-OTES *ortho* ester **25** as the minor (20%). Only **25** was obtained with a large excess of TESCl. This compound was isolated



Scheme 4.

Table 1. Product distribution of the silylation of **1** (1.0 equiv) with TMSCl, TESCl, TIPSCl, and BSA

Entry	Reaction conditions eq:eq:eq	A <sup>a</sup>	B <sup>b</sup>	C <sup>c</sup>	Overall yield %
1	1/TMSCl/DBU 1.0:2.5:2.0 (CH <sub>2</sub> Cl <sub>2</sub> )	21/22 = 0.94 <sup>d</sup> (1.14) <sup>e</sup>	23/24 = 1.1 <sup>d</sup> (1.6) <sup>e</sup>	3 (<5%) <sup>d,e</sup>	21 + 22 + 23 + 24 = 87 <sup>d</sup>
2	1/TMSCl/DBU 1.0:7.0:6.0 (CH <sub>2</sub> Cl <sub>2</sub> )	—	23/24 = 1.4 <sup>f</sup>	3 (<5%)	23 + 24 = 92 <sup>f</sup>
3	1/TESCl/DBU 1.0:6.0:7.0 (CH <sub>3</sub> CN)	—	25/26 = 1.2	—	25 + 26 = 93 <sup>f</sup>
4	1/TESCl/ <sup>t</sup> BuOK 1.0:1.7:2.5 (THF)	27 (80%) <sup>f</sup>	25 (20%) <sup>f</sup>	—	25 + 27 = 100
5	1/TESCl/ <sup>t</sup> BuOK 1.0:6.0:5.0 (THF)	—	25	—	25 = 94
6	1/TIPSCl/ <sup>t</sup> BuOK 1.0:5.0:6.0	—	—	29 (55%)	29 + 1 = 86
7	1/BSA 1.0:2.5 (CD <sub>3</sub> CN)	21/22 = 1.5	—	3 (33%) <sup>f</sup>	21 + 22 + 3 = 53 <sup>f</sup>
8	1/BSA/DMAP 1.0:2.5:0.2 (CD <sub>3</sub> CN)	21/22 = 1.5	23/24 = 4	—	21 + 22 + 23 + 24 = 100 <sup>f</sup>

<sup>a</sup> A: 13-oxo 21-*ortho* esters.

<sup>b</sup> B: 13-silyl enol 21-*ortho* esters.

<sup>c</sup> C: 13-Silyl enol ethers.

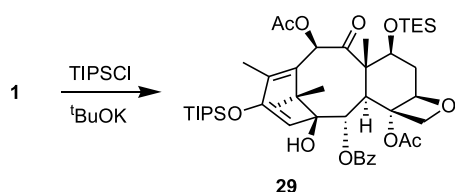
<sup>d</sup> Product distribution and overall yield after chromatography on silica.

<sup>e</sup> Product distribution as determined by <sup>1</sup>H NMR.

<sup>f</sup> Product distribution and overall yield after chromatography on alumina.

in 94% yield after chromatography on Al<sub>2</sub>O<sub>3</sub> (entry 5).<sup>23</sup> Although we failed to directly obtain the 13-silyl enol ether **28** through this route we successfully achieved a total chemoselectivity in the formation of the precursors 13-OTES *ortho* esters **25** and **26**.

(iii) *Silylation of 1 with TIPSCl and <sup>t</sup>BuOK*. The reaction of the enolate of **1** with 5.0 equiv of TIPSCl at –78 °C required <sup>t</sup>BuOK as base and a polar mixed solvent (THF/DMPU, 4:1). The 13-OTIPS-enol ether derivative **29** was obtained in 55% yield along with unreacted **1** (entry 6 and Scheme 5). This result gave evidence that sterically demanding silylating agents, such as TIPSCl, favor the enolization pathway instead of the formation of products derived from the 21-oxyanion.



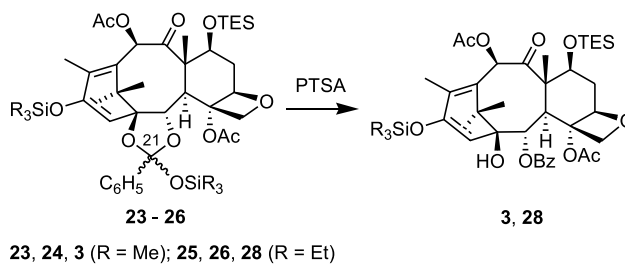
Scheme 5.

(iv) *Silylation of 1 with N, O bis(trimethylsilyl)acetamide (BSA)*. The silylation of **1** with 2.5 equiv of BSA in CD<sub>3</sub>CN gave the silyl enol ether **3** as the major product (33%) and the 13-oxo-*ortho* esters **21** and **22** (20%) (entry 7). Only *ortho* esters **21/22**=1.5 (65% yield) and **23/24**=4 (35%) were obtained when the same reaction was performed in the presence of the base DMAP (0.2 equiv, entry 8).

In conclusion, <sup>1</sup>H NMR experiments clearly showed that the DBU induced silylation of **1** with a slight excess of TMSCl (1.5–2.0 equiv) initially gave  $\alpha/\beta$  epimeric mixtures of the 13-oxo *ortho* esters **21** and **22** and traces of the 13-OTMS silyl enol ether **3**. Sequential silylation of **21** and **22** furnished the 13, 21-bis-silylated *ortho* esters **23** and **24**. Hence, variable mixtures of compounds **21–24** were obtained, along with trace amounts of **3**, depending on the reagents' stoichiometry. Only the potent BSA directly afforded moderate amounts of the silyl enol ether **3** as the major product, but in a non-basic medium (entry 7). The 13, 21-bis-silyl enol *ortho* esters **23–26** were obtained in very high yield (92–94%, entries 2, 3, and 5 of Table 1) when an excess of base and silylating agent was used. The folded terpenoid structure of the taxane skeleton favors an attack to the less hindered C-21 $\beta$  oxyanion only when the sterically demanding TES-Cl and TIPSCl are the electrophilic partners. Moreover, both the nature of the base, and the temperature play a key role on the chemo and diastereoselectivity at the C-21 position. For example, face discrimination was observed in the <sup>t</sup>BuOK induced reaction of **1** with TESCl, which afforded only the  $\beta$ -epimers **25** and **27** at low temperatures (entries 4 and 5, Table 1). This discrimination did not occur when this reaction was done in refluxing CH<sub>2</sub>Cl<sub>2</sub> with DBU as the base (entry 3).

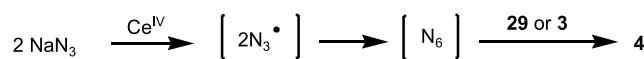
**2.2.2. Solvolysis of the *ortho* esters enolates 23–26.** While we failed to directly synthesize the 13-silyl enol ethers **3** and **28** in good yield by silylation of the enolate of **1**, we

achieved this target by performing a study of chemo-selective solvolysis of the silyl group at the C-21 carbon atom of the 13, 21-bis-OTMS-silyl enol *ortho* esters **23–26**. The desilylation of mixtures of **23/24** (or **25/26**), performed according to the reported procedure (1.0 M HCl),<sup>7</sup> afforded non-reproducible mixtures of silyl enol ethers **3** or **28** and the reagent **1**. Moreover, the  $\beta$ -epimers **23** and **25** were desilylated more rapidly than the  $\alpha$ -epimers **24** and **26**, thus favouring an uncontrolled formation of **1**. This selectivity was again the result of the folded structure of the baccatin skeleton, since the 21-OTMS substituent of the  $\alpha$ -epimers is more embedded of the  $\beta$ -epimers and, for this reason, less prone toward solvolysis. When we carried out solvolysis studies at different pH values we found that the priority of the desilylation at the C-13 and C-21 positions reversed with the pH of the medium. In fact, the desilylation of **23** and **24** in a basic medium, such as a mixture of DBU/water, afforded the 13-oxo *ortho* esters **21** and **22**, which in turn were hydrolyzed to **1**. This was the reason why the reactions of **1** with Me<sub>3</sub>SiCl, reported in section i, required an excess of Me<sub>3</sub>SiCl with respect to DBU for their quantitative conversion into **23** and **24** (entry 2). By contrast, the reaction of **1** with TESCl gave **25** and **26** although it was carried out with an excess of DBU, since the TES substituent is three order more stable toward base-catalysed hydrolysis.<sup>24</sup> Harsh desilylation agents, such as TBAF and CsF<sub>2</sub>, gave random mixtures of product of solvolysis at C-13, C-21, C-7, and contaminants. These attempts suggested that the selective C-21 desilylation could be carried out only in a very mild acidic medium, that is, with catalytic PTSA (8%) in CH<sub>2</sub>Cl<sub>2</sub> at 20 °C. When **23/24**=1.4, or **25/26**=1.25 mixtures were desilylated under these conditions, the enol ethers **3** (95%) and **28** (93%) were exclusively obtained (Scheme 6).

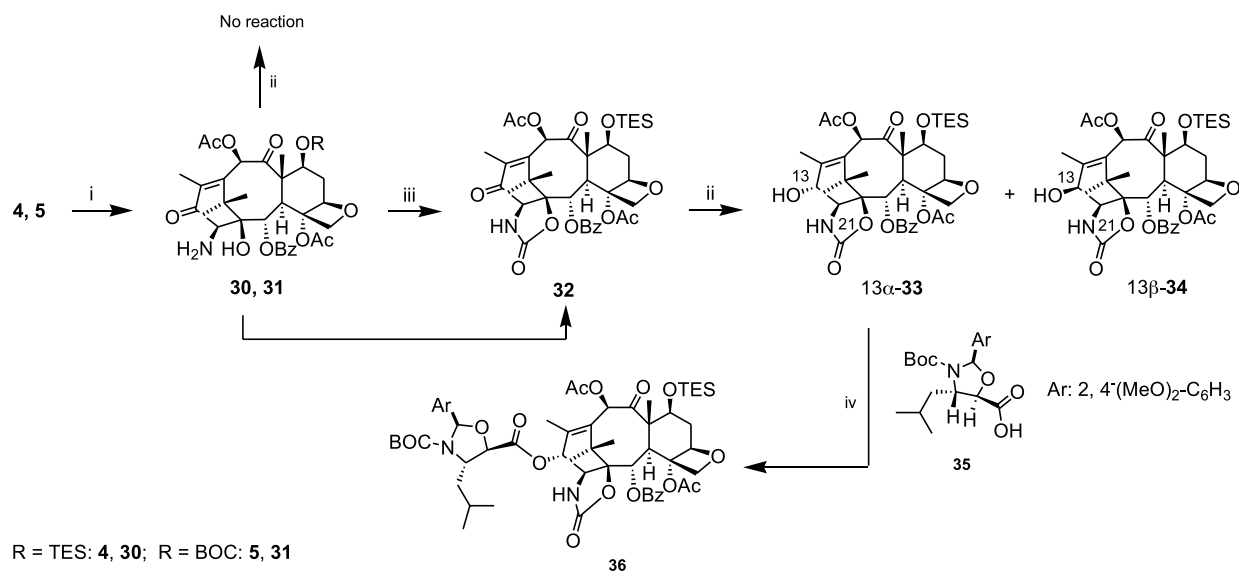


Scheme 6.

**2.2.3. Protocol B. CAN induced azidation of the silyl enol ethers 3 and 29. Synthesis of 7-TES-13-oxo-14 $\beta$ -azido-baccatin III (4).** The azidation of silyl enol ethers with NaN<sub>3</sub> represents an interesting protocol of  $\alpha$ -amination of ketones. This protocol is based on the oxidation of sodium azide by cerium(IV) ammonium nitrate to give dinitrogen, a very potent aminating agent.<sup>25</sup> This reagent has been successfully experimented mainly with silyl enol ethers bearing a sterically encumbered TIPS substituent, such as **29**.<sup>26</sup> The azidation of **29** in CH<sub>3</sub>CN occurred in 1 day under forced conditions, such as a large excess of NaN<sub>3</sub> (11.0 equiv) and CAN (7.0 equiv), the target **4** being obtained in moderate



Scheme 7.



**Scheme 8.** Reagents and conditions: (i) PPh<sub>3</sub>/H<sub>2</sub>O; (ii) NaBH<sub>4</sub>/EtOH; (iii) COCl<sub>2</sub>/Py; (iv) DCC/DMAP/PTSA.

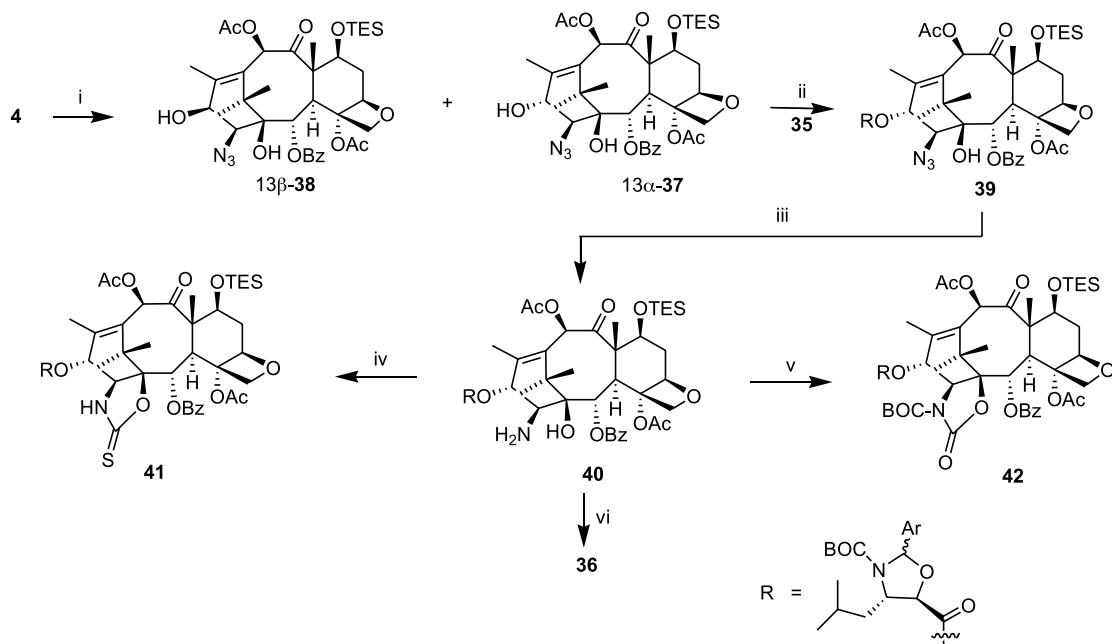
amounts (55%) (Scheme 7). For this reason, we also probed the less sterically demanding compound **3** even if the OTMS silyl enol ethers are usually prone toward a concurrent hydrolysis due to the acidic CAN medium. Gratifying, compound **4** was obtained in 95% yield after 1 h at 20 °C when **3** was reacted with only 4.0 equiv of NaN<sub>3</sub> and 3.0 equiv of CAN.

### 2.3. Synthesis of 14β-amino taxanes

The reduction of the azido group of **4** and **5** was carried out via the iminophosphorane method with PPh<sub>3</sub> in 9:1 CH<sub>3</sub>CN/H<sub>2</sub>O to give the 7-TES-13-oxo-14β-amino-baccatin III (**30**) in 88% yield, and its 7-BOC analogue **31** in 77% (Scheme 8). The attempted reduction of the 13-oxo group of **30** and **31** with sodium or alkyl boron hydrides failed, probably due

to a condensation of the hydride reagents with the 14-NH<sub>2</sub> group.<sup>27</sup> For this reason, the 14-NH<sub>2</sub> and the 1-OH groups of **30** were transformed into the 1, 14-carbamate group of compound **32** by treatment with phosgene in pyridine (86% yield). Next, **32** was reduced by NaBH<sub>4</sub> in EtOH affording the 13α-epimer of 7-TES-14β-amino baccatin III 1,14-carbamate (13α-**33**) in 56% and its 13β-OH epimer (13β-**34**, 35%).<sup>28</sup> *N*-Boc-norstatinic acid **35**, protected as *N,O*-(2,4-dimethoxy-benzylidene) derivative,<sup>29</sup> was selected as the partner of 13α-**33** since this amino acid was also present in Ortataxel. The esterification was carried out with *N,N'*-dicyclohexyl-carbodiimide (DCC), 4-dimethyl-amino-pyridine (DMAP) and catalytic *p*-toluenesulfonic acid,<sup>30</sup> affording the fully protected taxane **36**.

Next, we reasoned that a 14β-azido taxane, with the amino



**Scheme 9.** Reagents and conditions: (i) NaBH<sub>4</sub>, EtOH; (ii) DCC/DMAP/PTSA; (iii) H<sub>2</sub>/Pd-C; (iv) (2-Pyridyl)<sub>2</sub>C=S; (v) BOC<sub>2</sub>O/Et<sub>3</sub>N/DMAP; (vi) COCl<sub>2</sub>/Py.

### 3. Conclusions

acid appendant and the terpenoid skeleton fully protected, might be a key intermediate for synthesis of other taxanes bearing the 14 $\beta$ -amino function. Hence, the 13-oxo group of **4** was reduced by sodium or alkylammonium borohydrides to afford a mixture of 7-TES-14 $\beta$ -azido-baccatin III (13 $\alpha$ -**37**), as the major product, and its 13 $\beta$ -OH epimer (13 $\beta$ -**38**) (Scheme 9). Best yield of 13 $\alpha$ -**37** (76%) were obtained with NaBH<sub>4</sub> in EtOH ( $\alpha/\beta$  = 91:9).

The stereochemistry at C-13 of 13 $\alpha$ -**37**, assessed by NOE experiments, was the same as the natural synthons DAB III and 14 $\beta$ -OH-DAB, as required for pharmacologically active taxanes. A 7% enhancement of the H-13 proton was observed upon irradiation of the H-2 proton, while no effect was noticed upon irradiation of H-14. This suggests that H-13 and H-2 are located on the same  $\beta$ -face. An opposite trend was found for the epimer 13 $\beta$ -**38**: a NOE effect of 9% was observed for the H-13 proton upon irradiation of H-14, since the two protons are located on the same  $\alpha$ -face. The esterification of 13 $\alpha$ -**37** with the acid **35**, following the standard protocol, gave the fully protected 14 $\beta$ -azido taxane **39** in 80% yield. Catalytic hydrogenation (10% Pd/C) of the azido group of **39** gave the 14 $\beta$ -amino analogue **40** in 90% yield. The 1 $\beta$ -OH and 14 $\beta$ -NH<sub>2</sub> groups of **40** were subjected to further elaborations that allowed the synthesis of other taxanes. Thiocarbonylation of **40** with di-2-pyridyl-thionocarbonate in CH<sub>3</sub>CN gave the 1,14-thiocarbamate derivative **41** in 73% yield, while the carbonylation of the 14 $\beta$ -amino derivative **37** with excess of BOC<sub>2</sub>O, Et<sub>3</sub>N and DMAP gave the *N*-BOC-1, 14-carbamate derivative **42** in 69%. It is worth noting that the taxane 1, 14 carbamate **36** was obtained in 74% yield by an independent route by carbonylation of the amino derivative **40** with COCl<sub>2</sub>/pyridine.

Finally, the sequential desilylation of the 7-OTES group of **36**, **39–42** with HF/pyridine, followed by *N*, *O*-deprotection of the isoserine moiety with acetyl chloride in MeOH, gave the target taxoids: 13-*N*-BOC- $\beta$ -isobutylisoserinoyl-14 $\beta$ -amino-baccatin III 14,1-carbamate (**43**), 13-(*N*-BOC- $\beta$ -isobutylisoserinoyl)-14 $\beta$ -azido-baccatin III (**44**), 13-(*N*-BOC- $\beta$ -isobutyl-isoserinoyl)-14 $\beta$ -amino-baccatin III (**45**), 13-(*N*-BOC- $\beta$ -isobutylisoserinoyl)-14 $\beta$ -amino-baccatin III 14,1-thiocarbamate (**46**), 13-(*N*-BOC- $\beta$ -isobutyl-isoserinoyl)-14 $\beta$ -*t*-butoxycarbonyl-baccatin III 14,1-carbamate (**47**) (Scheme 10).

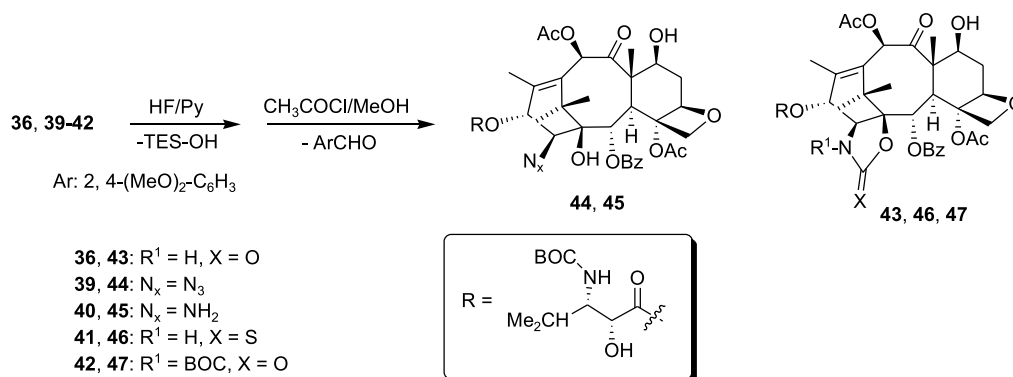
A preliminary optimization of the synthesis of silyl enol ethers has been carried out. We have clearly identified an high yield protocol for the conversion of **1** into 13,21-bisilylated enol ethers *ortho* esters **23–26** using an excess of silylating agent and base. The lability of the silyl substituent at C-21 provides a way for an high recovery of the 13-silyl enol ethers **3** and **28** only when a suitable reagent, PTSA, is adopted for the chemoselective desilylation at C-21 of the  $\alpha/\beta$ -epimeric mixtures. The use of alumina instead of silica for chromatographic purification was required to prevent uncontrolled desilylation of the intermediates. Instead, the 13-OTIPS enol ether **29** was obtained in an one step process but in a moderate amounts.

Moreover, we have developed useful protocols for the synthesis of 14 $\beta$ -nitrogen functionalized taxanes. These compounds were synthesized starting from the commercially available 10-DAB III. Key steps of this protocol were the azidation of the enolates of 13-oxo-baccatins **1** and **2** with tosyl azide, or the azidation of the 13-silyl enol ethers **3** and **29** with NaN<sub>3</sub> under oxidative conditions. Both amination protocols occurred with total  $\beta$ -stereoselectivity regardless of the type of aminating agent (azodicarboxylates, tosyl azide, NaN<sub>3</sub>) to afford the key intermediate 14 $\beta$ -azido derivatives **4** and **5**. This selectivity was induced by the folded structure of the taxane skeleton, which favors the approach of the aminating agent from the less hindered  $\beta$ -face. In particular, we have prepared the fully protected 14 $\beta$ -azido taxane **39** from compound **4** using standard procedures. This compound was the key intermediate for the synthesis of a new family of 14 $\beta$ -amino taxanes (**43–47**) whose study of antitumor *in vitro* and *in vivo* activity is actively under way.<sup>31</sup>

### 4. Experimental

#### 4.1. General techniques

Solvents were purified and dried prior to use. Reactions were monitored by thin-layer chromatography on 0.25mm E. Merck silica gel plates (60 F254) using UV light as a visualizing agent or a 7% ethanolic phosphomolibdic acid as developing agent. <sup>1</sup>H and <sup>13</sup>C NMR spectra were recorded on a 400 MHz spectrometer with Me<sub>4</sub>Si or CHCl<sub>3</sub> (in



Scheme 10.

$\text{CDCl}_3$ ) as internal reference. Infrared Spectra were recorded on a Fourier transform IR spectrometer, and values are reported in  $\text{cm}^{-1}$  units. Positive Ion mass spectra were obtained by direct infusion of 1.2 mM solutions in 0.02 M ammonium acetate/MeOH, 20/80 at an ion trap mass spectrometer Thermoquest LCQ-duo (Finnigan USA) equipped with an ESI ionization source.

**4.1.1. 7-TES-13-oxo-14-(*N,N'*-bis-(benzyloxycarbonyl)hydrazino)-baccatin III (9).** A solution of **1** (0.45 g, 0.64 mmol) in THF (12.0 mL) and DMPU (2.5 mL) was cooled to  $-72^\circ\text{C}$  and stirred under nitrogen.  $^t\text{BuOK}$  (1.61 mL, 1.61 mmol, 1.0 M in THF) was added dropwise and the solution stirred at  $-65^\circ\text{C}$  for 45 min. Then compound **6** (0.28 g, 0.82 mmol) was added and the reaction monitored by TLC. After 2 h the conversion was not complete, so a further amount of **6** (0.07 g, 0.2 mmol) was added. After 1 h (total reaction time: 3 h) the reaction was quenched with acetic acid (0.15 mL, 40% in THF) and warmed to room temperature. After dilution with brine (10.0 mL) the mixture was extracted with EtOAc and the organic layer washed with brine (10.0 mL), dried and evaporated. The residue was purified by chromatography ( $\text{SiO}_2$ ,  $\text{CH}_2\text{Cl}_2/\text{EtOAc}$ , 1.0:0.2) to obtain 0.49 g (0.49 mmol, 76%) of **9** as a white solid. IR (KBr,  $\text{cm}^{-1}$ ): 3394, 2993, 2920, 1725, 1342, 1212;  $[\alpha]_D^{20} +53.6$  (*c* 0.12,  $\text{CHCl}_3$ ); MS (*m/z*) ESI: 998 ( $\text{M}+\text{H}^+$ );  $^1\text{H}$  NMR ( $\text{CDCl}_3$ , 200 MHz)  $\delta$  8.27–8.32 (m, 2H, arom), 7.19–7.55 (m, 13H, arom), 6.87 (s, 1H, NH), 6.53 (s, 1H, H-10), 5.99 (d, 1H, H-2,  $J=6.6$  Hz), 5.63 (s, 1H, H-14), 5.16 (d, 2H,  $J=4.8$  Hz,  $\text{CH}_2\text{Ph}$ ), 5.04 (d, 2H,  $J=4.8$  Hz,  $\text{CH}_2\text{Ph}$ ), 4.88 (d, 1H, H-5,  $J=4.0$  Hz), 4.51 (dd, 1H, H-7,  $J=6.6, 4.0$  Hz), 4.34–4.36 (m, 2H, H-20), 4.01 (d, 1H, H-3,  $J=6.6$  Hz), 2.42–2.61 (m, 1H, H $\alpha$ -6), 2.23 (s, 3H, Me), 2.22 (s, 3H, Me), 2.15 (s, 3H, Me), 1.84–1.98 (m, 1H, H $\beta$ -6), 1.74 (s, 3H, Me), 1.29 (s, 3H, Me), 1.28 (s, 3H, Me), 0.90–0.98 (m, 9H, 3 Me), 0.58–0.66 (m, 6H, 3  $\text{CH}_2$ );  $^{13}\text{C}$  NMR ( $\text{CDCl}_3$ , 50 MHz)  $\delta$  200.1, 196.7, 171.9, 169.3, 166.3, 158.1, 157.1, 138.0, 135.5, 135.2, 133.6, 131.3, 129.5, 129.0, 128.9, 128.7, 128.5, 127.7, 84.6, 81.3, 75.8, 75.3, 74.0, 72.5, 69.6, 68.9, 66.3, 59.6, 46.0, 43.7, 37.6, 34.8, 22.2, 21.1, 20.2, 14.2, 10.2, 7.1, 5.6. Anal. Calcd  $\text{C}_{53}\text{H}_{64}\text{N}_2\text{O}_{15}\text{Si}$ : C, 63.84; H, 6.47; N, 2.81. Found: C, 63.70; H, 6.51; N, 2.67.

**4.1.2. 7-BOC-13-oxo-14 $\beta$ -[*N,N'*-bis-(benzyloxycarbonyl)hydrazino]-baccatin III (10).**  $^t\text{BuOK}$  (0.16 g, 1.47 mmol) was suspended, under nitrogen and stirring, in 3.0 mL of anhydrous THF at  $-72^\circ\text{C}$ . 7-BOC-13-oxo-baccatin III **2** (0.37 g, 0.54 mmol) in 2.5 mL of THF and 1.8 mL of DMPU was added. After 15 min, 0.32 g (1.19 mmol) of **6**, dissolved in 3.0 mL of THF and 0.2 mL of DMPU was added at  $-68^\circ\text{C}$ . Temperature was raised to  $-50^\circ\text{C}$ , and after 8 h the reaction mixture was quenched by addition of 2.0 mL (0.03 mmol) of acetic acid, diluted with 10.0 mL of ethyl ether, and extracted with 10.0 mL of saturated solution of  $\text{NH}_4\text{Cl}$ . The organic phases was washed with water, dried, filtered, and evaporated under reduced pressure. Chromatography of the residue ( $\text{SiO}_2$ , *n*-hexane/EtOAc, 1.3:1.0) afforded 0.35 g (0.35 mmol, 65%) of **10** as a white solid. IR (KBr,  $\text{cm}^{-1}$ ): 3397, 2983, 2930, 1728, 1393, 1252;  $[\alpha]_D^{20} +58.4$  (*c* 0.42,  $\text{CH}_2\text{Cl}_2$ ); MS (*m/z*) ESI: 984 ( $\text{M}+\text{H}^+$ );  $^1\text{H}$  NMR ( $\text{CDCl}_3$ , 400 MHz)  $\delta$  8.24–8.37 (m, 2H, arom), 7.50–7.55 (m, 1H, arom), 7.34–7.40 (m, 2H, arom),

7.15–7.30 (m, 10H, arom), 6.89 (s, 1H, NH), 6.56 (s, 1H, H-10), 5.97 (d, 1H, H-2,  $J=6.2$  Hz), 5.62 (s, 1H, H-14), 5.18 (d, 1H,  $\text{CH}_2\text{Ph}$ ,  $J=12.5$  Hz), 5.34–5.38 (m, 1H, H-7), 5.12 (d, 1H,  $\text{CH}_2\text{Ph}$ ,  $J=12.5$  Hz), 5.06 (d, 1H,  $\text{CH}_2\text{Ph}$ ,  $J=12.5$  Hz), 4.99 (d, 1H,  $\text{CH}_2\text{Ph}$ ,  $J=12.5$  Hz), 4.92 (dd, 1H, H-5,  $J=2.5, 9.5$  Hz), 4.37 (d, 2H, H-20,  $J=8.6$  Hz), 4.14 (d, 1H, H-3,  $J=6.2$  Hz), 2.59 (ddd, 1H, H $\alpha$ -6,  $J=7.2, 9.5, 14.3$  Hz), 2.19 (s, 3H, Me), 2.18 (s, 3H, Me), 2.13 (s, 3H, Me), 1.97 (ddd, 1H, H $\beta$ -6,  $J=2.5, 10.9, 14.3$  Hz), 1.82 (s, 3H, Me), 1.47 (s, 9H, 3 Me), 1.23 (s, 3H, Me), 0.86 (s, 3H, Me);  $^{13}\text{C}$  NMR ( $\text{CDCl}_3$ , 100 MHz)  $\delta$  200.2, 196.4, 171.7, 168.4, 166.2, 158.0, 157.0, 153.3, 152.6, 138.4, 135.3, 135.0, 133.6, 131.1, 129.2, 128.9, 128.8, 128.7, 128.6, 128.5, 128.3, 127.5, 84.2, 83.3, 80.9, 76.8, 75.8, 75.2, 74.4, 73.6, 69.5, 68.8, 66.1, 57.2, 45.9, 43.5, 33.6, 27.9, 22.0, 21.0, 20.1, 14.4, 10.9. Anal. Calcd for  $\text{C}_{52}\text{H}_{58}\text{N}_2\text{O}_{17}$ : C, 63.53; H, 5.95; N, 2.85. Found: C, 63.50; H, 6.02; N, 2.77.

**4.1.3. 7-BOC-13-oxo-14 $\beta$ -[*N,N'*-bis-(*tert*-butoxycarbonyl)hydrazino]-baccatin III (11).**  $^t\text{BuOK}$  (0.16 g, 1.47 mmol) was suspended, under nitrogen and stirring, in 3.0 mL of anhydrous THF at  $-72^\circ\text{C}$ . Compound **2** (0.37 g, 0.54 mmol) in 2.5 mL of THF and 1.8 mL of DMPU was added to the mixture. Compound **7** (0.27 g, 1.19 mmol), dissolved in 3.0 mL of THF and 0.2 mL of DMPU, was added after 15 min at  $-68^\circ\text{C}$ . After 1 h the reaction was quenched by addition of 2.0 mL (0.03 mmol) of acetic acid, diluted with ethyl ether and extracted with a saturated aqueous solution of  $\text{NH}_4\text{Cl}$ . The organic phase was washed with water, dried, filtered and evaporated under reduced pressure. Chromatography of the residue ( $\text{SiO}_2$ , *n*-hexane/EtOAc, 1.2:1.0) afforded 0.36 g (0.38 mmol, 72%) of **11** as a solid. IR (KBr,  $\text{cm}^{-1}$ ): 3408, 2980, 2933, 1728, 1682, 1369, 1255, 1155;  $[\alpha]_D^{20} +57.0$  (*c* 0.75,  $\text{CH}_2\text{Cl}_2$ ); MS (*m/z*) ESI: 916 ( $\text{M}+\text{H}^+$ );  $^1\text{H}$  NMR ( $\text{CDCl}_3$ , 400 MHz)  $\delta$  8.27–8.30 (m, 2H, arom), 7.50–7.55 (m, 1H, arom), 7.38–7.42 (m, 2H, arom), 6.58 (s, 1H, N-H), 6.53 (s, 1H, H-10), 5.97 (d, 1H, H-2,  $J=6.4$  Hz), 5.58 (s, 1H, H-14), 5.41 (dd, 1H, H-7,  $J=6.9, 10.7$  Hz), 4.90 (dd, 1H, H-5,  $J=2.6, 9.7$  Hz), 4.35 (d, 1H, H-20,  $J=8.4$  Hz), 4.23 (d, 1H, H-20,  $J=8.4$  Hz), 4.15 (d, 1H, H-3,  $J=6.4$  Hz), 2.59 (ddd, 1H, H $\alpha$ -6,  $J=6.9, 9.7, 14.3$  Hz), 2.21 (s, 3H, Me), 2.18 (s, 3H, Me), 2.17 (s, 3H, Me), 1.97 (ddd, 1H, H $\beta$ -6,  $J=2.6, 10.7, 14.3$  Hz), 1.82 (s, 3H, Me), 1.46 (s, 9H, 3 Me), 1.40 (s, 9H, 3 Me), 1.35 (s, 9H, 3 Me), 1.26 (s, 3H, Me), 1.00 (s, 3H, Me);  $^{13}\text{C}$  NMR ( $\text{CDCl}_3$ , 100 MHz)  $\delta$  200.4, 196.9, 171.7, 168.4, 166.2, 157.3, 155.8, 153.2, 152.6, 138.5, 133.3, 131.2, 129.4, 128.4, 84.2, 83.3, 83.2, 82.7, 80.9, 76.8, 76.1, 75.0, 74.5, 73.4, 65.1, 57.3, 45.9, 43.6, 34.6, 33.7, 28.2, 28.1, 27.9, 21.9, 21.0, 20.1, 14.3, 10.9. Anal. Calcd  $\text{C}_{46}\text{H}_{62}\text{N}_2\text{O}_{17}$ : C, 60.38; H, 6.83; N, 3.06. Found: C, 60.30; H, 6.71; N, 3.14.

**4.1.4. 7-TES-13-oxo-14 $\beta$ -hydrazino-baccatin III (12).** A solution of **9** (0.50 g, 0.50 mmol) in EtOAc (45.0 mL) was hydrogenated under balloon pressure with 10% Pd/C as catalyst (0.05 g) for 45 min. The catalyst was filtered off through celite, the solvent was evaporated under reduced pressure without heating to obtain 0.35 g of **12** (0.48 mmol, 96%). This compound was unstable in various conditions (chromatographic column) and solvents ( $\text{CDCl}_3$ ). (**12**): IR (KBr,  $\text{cm}^{-1}$ ): 3340, 2980, 1734, 1252;  $^1\text{H}$  NMR ( $\text{CDCl}_3$ , 200 MHz) relevant resonances at  $\delta$  8.19–8.23 (m, 2H, arom), 7.41–7.61 (m, 3H, arom), 6.54 (s, 1H, H-10), 5.85 (d,

1H, H-2,  $J=6.6$  Hz), 5.37 (s, 1H), 5.18 (s, 1H), 4.92 (d, 1H, H-5,  $J=8.1$  Hz), 4.51 (m, 1H, H-7), 4.29 (s, 2H, H-20), 3.92 (d, 1H, H-3,  $J=7.0$  Hz), 2.47–2.62 (m, 1H, H $\alpha$ -6), 2.25 (s, 3H, Me), 2.23 (s, 3H, Me), 2.06 (s, 3H, Me), 1.84–1.98 (m, 1H, H $\beta$ -6), 1.74 (s, 3H, Me), 1.31 (s, 3H, Me), 1.28 (s, 3H, Me), 0.90–0.98 (m, 9H, 3 Me).

**4.1.5. 7-TES-13-oxo-14-diazo-baccatin III (17).** 0.8 mL of a 1.0 M solution of <sup>t</sup>BuOK in THF was added under stirring at  $-72$  °C to a solution of 0.22 g (0.32 mmol) of **1** in 3.5 mL of THF and 1.0 mL of DMPU. Tosyl azide (0.11 g, 0.58 mmol), dissolved in 0.9 mL of THF was added after 15 min. The temperature was raised to  $-50$  °C and the reaction was quenched after 1 h by addition of 0.8 mL of acetic acid. The reaction temperature was raised at  $20$  °C and the mixture left for 12 h. The reaction mixture was extracted with Et<sub>2</sub>O and the organic phase was dried, filtered and evaporated under reduced pressure. Chromatography of the residue (SiO<sub>2</sub>, *n*-hexane/EtOAc, 2.1:1.0) afforded 0.19 g of **17** as a white solid (0.26 mmol, 82%). IR (KBr, cm<sup>-1</sup>): 3358, 3261, 2957, 2877, 2097, 1727, 1628, 1369, 1306, 1161; [ $\alpha$ ]<sub>D</sub><sup>20</sup> +66.0 (*c* 0.9, CH<sub>2</sub>Cl<sub>2</sub>); MS (*m/z*) ESI: 726 (M+H)<sup>+</sup>; <sup>1</sup>H NMR (CDCl<sub>3</sub>, 400 MHz)  $\delta$  8.10–8.20 (m, 2H, arom), 7.59–7.62 (m, 1H, arom), 7.42–7.50 (m, 2H, arom), 6.50 (s, 1H, H-10), 5.84 (d, 1H, H-2,  $J=7.2$  Hz), 4.92 (dd, 1H, H-5,  $J=2.2$ , 9.7 Hz), 4.47 (dd, 1H, H-7,  $J=6.7$ , 10.7 Hz), 4.33 (d, 1H, H-20,  $J=8.2$  Hz), 4.07 (d, 1H, H-20,  $J=8.2$  Hz), 3.89 (d, 1H, H-3,  $J=7.2$  Hz), 2.53 (ddd, 1H, H $\alpha$ -6,  $J=6.7$ , 9.7, 14.2 Hz), 2.21 (s, 3H, Me), 2.20 (s, 3H, Me), 2.16 (s, 3H, Me), 1.85 (ddd, 1H, H $\beta$ -6,  $J=2.2$ , 10.7, 14.2 Hz), 1.65 (s, 3H, Me), 1.28 (s, 3H, Me), 1.26 (s, 3H, Me), 0.89–0.92 (m, 9H, 3 Me), 0.54–0.58 (m, 6H, 3 CH<sub>2</sub>); <sup>13</sup>C NMR (CDCl<sub>3</sub>, 100 MHz)  $\delta$  200.6, 183.9, 170.3, 168.9, 167.0, 146.4, 140.4, 134.3, 130.4, 130.2, 129.0, 84.2, 80.6, 79.5, 76.5, 76.0, 74.0, 72.3, 69.6, 59.1, 45.9, 43.0, 37.4, 33.1, 22.0, 21.2, 18.9, 14.4, 10.4, 7.2, 5.7. Anal. Calcd C<sub>37</sub>H<sub>48</sub>N<sub>2</sub>O<sub>11</sub>Si: C, 61.31; H, 6.67; N, 3.86. Found: C, 61.39; H, 6.75; N, 3.92.

**4.1.6. 7-BOC-13-oxo-14-diazo-baccatin III (18).** A solution of **2** (0.15 g, 0.22 mmol) in THF (0.7 mL) and DMPU (0.4 mL) was added under nitrogen and stirring to a suspension of <sup>t</sup>BuOK (0.06 g, 0.57 mmol) in anhydrous THF (0.7 mL) at  $-72$  °C. After 15 min, a solution of tosyl azide (0.08 g, 0.39 mmol) in 0.5 mL of THF was added. The temperature was raised to  $-50$  °C and the reaction was quenched after 2 h by addition of 1.0 mL of acetic acid. Work-up of the reaction mixture was performed as described for compound **17**. Chromatography of the crude residue (SiO<sub>2</sub>, *n*-hexane/EtOAc, 1.7:1.0) yielded 0.11 g of compound **18** (0.16 mmol, 72%) as a white solid. IR (KBr, cm<sup>-1</sup>): 3359, 2957, 2878, 2097, 1726, 1630, 1305; [ $\alpha$ ]<sub>D</sub><sup>20</sup> +72.6 (*c* 0.3, CH<sub>2</sub>Cl<sub>2</sub>); MS (*m/z*) ESI: 712 (M+H)<sup>+</sup>; <sup>1</sup>H NMR (CDCl<sub>3</sub>, 400 MHz)  $\delta$  8.17–8.22 (m, 2H, arom), 7.62–7.68 (m, 1H, arom), 7.48–7.54 (m, 2H, arom), 6.50 (s, 1H, H-10), 5.85 (d, 1H, H-2,  $J=7.2$  Hz), 5.41 (dd, 1H, H-7,  $J=6.8$ , 10.8 Hz), 4.95 (dd, 1H, H-5,  $J=1.5$ , 8.0 Hz), 4.36 (d, 1H, H-20,  $J=8.4$  Hz), 4.08 (d, 1H, H-20,  $J=8.4$  Hz), 4.04 (d, 1H, H-3,  $J=7.2$  Hz), 2.63 (ddd, 1H, H $\alpha$ -6,  $J=6.8$ , 8.0, 14.0 Hz), 2.22 (s, 3H, Me), 2.19 (s, 3H, Me), 2.18 (s, 3H, Me), 1.92 (ddd, 1H, H $\beta$ -6,  $J=1.5$ , 8.0, 14.0 Hz), 1.77 (s, 3H, Me), 1.48 (s, 9H, 3Me), 1.31 (s, 3H, Me), 1.23 (s, 3H, Me); <sup>13</sup>C NMR (CDCl<sub>3</sub>, 100 MHz)  $\delta$  200.9, 184.1, 170.4,

168.3, 167.3, 152.5, 145.7, 141.1, 134.5, 130.4, 129.1, 128.3, 84.0, 83.5, 80.4, 79.5, 76.3, 76.2, 74.5, 73.7, 65.4, 56.6, 46.1, 43.0, 33.5, 32.9, 27.9, 21.0, 18.7, 14.4, 11.1. Anal. Calcd C<sub>36</sub>H<sub>42</sub>N<sub>2</sub>O<sub>13</sub>: C, 60.84; H, 5.96; N, 3.94. Found: C, 60.70; H, 5.85; N, 4.03.

**4.1.7. 7-TES-13-oxo-14 $\beta$ -azido-baccatin III (4).** A solution of 1.40 g (2.0 mmol) of **1** in 7.5 mL of THF and 3.7 mL of DMPU, was added to a solution of <sup>t</sup>BuOK (5.2 mL, 5.2 mmol, 1.0 M in THF) at  $-72$  °C under stirring. Tosyl azide (0.70 g, 3.6 mmol), dissolved in 5.8 mL of THF, was added after 10 min. The temperature was raised to  $-50$  °C and the reaction was quenched after 2 h by addition of 10.0 mL of saturated aqueous NH<sub>4</sub>Cl. The reaction mixture was left at  $25$  °C for 12 h, diluted with 50.0 mL of Et<sub>2</sub>O and extracted. The organic phase was washed with water, dried, filtered and concentrated under reduced pressure. Chromatography of the residue (SiO<sub>2</sub>, *n*-hexane/EtOAc/Et<sub>2</sub>O, 1.8:0.7:0.4) gave 1.34 g (1.8 mmol, 92%) of **4** as a white solid. IR (KBr, cm<sup>-1</sup>): 3497, 2956, 2878, 2117, 1730, 1689, 1370, 1238, 1094; [ $\alpha$ ]<sub>D</sub><sup>20</sup> +79.4 (*c* 0.9, CH<sub>2</sub>Cl<sub>2</sub>); MS (*m/z*) ESI: 741 (M+H)<sup>+</sup>; <sup>1</sup>H NMR (CDCl<sub>3</sub>, 400 MHz)  $\delta$  8.02–8.04 (m, 2H, arom), 7.60–7.65 (m, 1H, arom), 7.47–7.53 (m, 2H, arom), 6.53 (s, 1H, H-10), 5.82 (d, 1H, H-2,  $J=6.7$  Hz), 4.92 (dd, 1H, H-5,  $J=2.0$ , 9.5 Hz), 4.46 (dd, 1H, H-7,  $J=6.7$ , 10.7 Hz), 4.33 (d, 1H, H-20,  $J=8.6$  Hz), 4.25 (s, 1H, H-14), 4.24 (d, 1H, H-20,  $J=8.6$  Hz), 3.86 (d, 1H, H-3,  $J=6.7$  Hz), 3.09 (s, 1H, OH), 2.54 (ddd, 1H, H $\alpha$ -6,  $J=6.7$ , 10.7, 14.2 Hz), 2.25 (s, 3H, Me), 2.22 (s, 3H, Me), 2.19 (s, 3H, Me), 1.91 (ddd, 1H, H $\beta$ -6,  $J=2.0$ , 9.5, 14.2 Hz), 1.72 (s, 3H, Me), 1.27 (s, 3H, Me), 1.00 (s, 3H, Me), 0.90–0.96 (m, 9H, 3 Me), 0.55–0.64 (m, 6H, 3 CH<sub>2</sub>); <sup>13</sup>C NMR (CDCl<sub>3</sub>, 100 MHz)  $\delta$  199.5, 196.5, 169.9, 169.0, 165.3, 155.4, 138.2, 134.0, 129.9, 129.2, 129.0, 84.0, 81.3, 76.3, 75.6, 75.5, 72.8, 72.5, 65.5, 59.6, 45.7, 43.4, 37.4, 34.0, 22.1, 21.2, 19.4, 14.4, 10.1, 7.2, 5.6. Anal. Calcd C<sub>37</sub>H<sub>49</sub>N<sub>3</sub>O<sub>11</sub>Si: C, 60.06; H, 6.68; N, 5.68. Found: C, 59.87; H, 6.79; N, 5.80.

**4.1.8. 7-BOC-13-oxo-14 $\beta$ -azido-baccatin III (5).** A solution of **2** (0.15 g, 0.22 mmol) in THF (1.8 mL) and DMPU (0.8 mL) was added to a suspension of <sup>t</sup>BuOK (0.06 g, 0.57 mmol) in anhydrous THF (1.5 mL) at  $-72$  °C, under nitrogen and stirring. After 15 min, 0.08 g (0.40 mmol) of tosyl azide, dissolved in 0.7 mL of THF, were added in 2 min at  $-75$  °C. After 30 min, the temperature was raised to  $-50$  °C and the reaction was quenched after 2 h by addition of 5.0 mL of saturated NH<sub>4</sub>Cl. The reaction mixture was extracted with Et<sub>2</sub>O and the organic phase was dried, filtered and evaporated under reduced pressure. Chromatography of the residue (SiO<sub>2</sub>, *n*-hexane/EtOAc, 1.7:1.0) gave 0.14 g (0.19 mmol, 85%) of **5** as a white solid. IR (KBr, cm<sup>-1</sup>): 2976, 2935, 2122, 1731, 1272, 1094; [ $\alpha$ ]<sub>D</sub><sup>20</sup> +69.4 (*c* 0.9, CH<sub>2</sub>Cl<sub>2</sub>); MS (*m/z*) ESI: 727 (M+H)<sup>+</sup>; <sup>1</sup>H NMR (CDCl<sub>3</sub>, 400 MHz)  $\delta$  8.02–8.05 (m, 2H, arom), 7.60–7.66 (m, 1H, arom), 7.48–7.52 (m, 2H, arom), 6.56 (s, 1H, H-10), 5.81 (d, 1H, H-2,  $J=6.8$  Hz), 5.37 (dd, 1H, H-7,  $J=7.2$ , 10.8 Hz), 4.93 (dd, 1H, H-5,  $J=2.0$ , 9.6 Hz), 4.33 (d, 1H, H-20,  $J=8.4$  Hz), 4.26 (s, 1H, H-14), 4.24 (d, 1H, H-20,  $J=8.4$  Hz), 3.98 (d, 1H, H-3,  $J=6.8$  Hz), 3.11 (s, 1H, OH), 2.62 (ddd, 1H, H $\alpha$ -6,  $J=7.2$ , 9.6, 14.0 Hz), 2.24 (s, 3H, Me), 2.20 (s, 3H, Me), 2.19 (s, 3H, Me), 1.96 (ddd, 1H, H $\beta$ -6,  $J=2.0$ , 10.8, 14.0 Hz), 1.81 (s, 3H, Me), 1.47 (s, 9H,

3 Me), 1.22 (s, 3H, Me), 1.01 (s, 3H, Me);  $^{13}\text{C}$  NMR ( $\text{CDCl}_3$ , 100 MHz)  $\delta$  199.8, 196.6, 170.0, 168.2, 165.4, 153.8, 152.5, 138.8, 134.1, 130.0, 129.2, 129.1, 83.7, 83.5, 81.0, 76.1, 75.8, 75.5, 74.4, 72.5, 65.4, 57.2, 45.8, 43.3, 33.7, 33.5, 27.9, 21.9, 20.9, 19.2, 14.4, 10.8. Anal. Calcd  $\text{C}_{36}\text{H}_{43}\text{N}_3\text{O}_{13}$ : C, 59.58; H, 5.97; N, 5.79. Found: C, 59.71; H, 5.90; N, 5.83.

**4.1.9. Synthesis of 7-TES-13-oxo-1,2-[ $\alpha$ -( $\beta$ -O-TMS)-benzylideneacetal]-baccatin III (21); 7-TES-13-oxo-1,2-[ $\alpha$ -( $\beta$ -O-TMS)-benzylideneacetal]-baccatin III (22); 7-TES-13-TMS-13,14-dehydro-1,2-[ $\alpha$ -( $\beta$ -O-TMS)-benzylideneacetal]-baccatin III (23); 7-TES-13-TMS-13,14-dehydro-1,2-[ $\alpha$ -( $\beta$ -O-TMS)-benzylideneacetal]-baccatin III (24).** A. *DBU induced silylation of 1 with  $\text{Me}_3\text{SiCl}$ .* (i) A solution of 0.30 g (0.42 mmol) of **1**, 0.13 g (0.84 mmol) of DBU, 0.11 g (1.05 mmol) of  $\text{Me}_3\text{SiCl}$ , in 8.0 mL of  $\text{CH}_2\text{Cl}_2$  was refluxed under nitrogen for 2 h. The reaction solution was treated with saturated aqueous solution of  $\text{NH}_4\text{Cl}$ . The organic layer was separated and extracted with water, dried, filtered, and evaporated under reduced pressure. The  $^1\text{H}$  NMR spectrum of the crude mixture ( $\text{CD}_3\text{COCD}_3$ ) showed a product distribution of **21/22/23/24** = 41:36:11:7 and minor amounts of unreacted **1** and of the silyl enol ether **3**. Chromatography ( $\text{SiO}_2$ , *n*-hexane/ $\text{CH}_2\text{Cl}_2$ /EtOAc, 14:6:3) gave 0.24 g (0.30 mmol, 71%) of a mixture of compounds **21** and **22** (**21/22** = 0.94), 0.06 g (0.07 mmol, 16%) of a mixture of compounds **23** and **24** (**23/24** = 1.1). All compounds are solid. (ii) A solution of 0.30 g (0.42 mmol) of **1**, 0.39 g (2.52 mmol) of DBU, 0.38 g (2.94 mmol) of  $\text{Me}_3\text{SiCl}$ , in 8.0 mL of  $\text{CH}_2\text{Cl}_2$  was refluxed under nitrogen for 2 h. The crude reaction mixture, obtained after the above described work up, was chromatographed on  $\text{Al}_2\text{O}_3$ , (*n*-hexane/EtOAc, 10:1) to give a mixture of **23** and **24** (0.33 g, 0.38 mmol, 92%, **23/24** = 1.4). B. *Silylation of 1 with BSA.* (i) 0.25 g (0.35 mmol) of 7-TES-13-oxo-baccatin III **1** and BSA (0.18 g, 0.88 mmol) were reacted in 5.0 mL of  $\text{CD}_3\text{CN}$  at 25 °C for 24 h at 20 °C. The crude reaction mixture, obtained after the above described work up, was chromatographed on  $\text{Al}_2\text{O}_3$ , (*n*-hexane/EtOAc, 10:1) to give compounds **3** (0.09 g, 0.11 mmol, 33%), **21** (0.03 g, 0.04 mmol, 12%), **22** (0.02 g, 0.03 mmol, 8%) and unreacted **1** (0.12 g, 0.17 mmol, 47%). (ii) 0.25 g (0.35 mmol) of **1** and BSA (0.18 g, 0.88 mmol) were reacted in 5.0 mL of  $\text{CD}_3\text{CN}$  and in the presence of 0.01 g (0.07 mmol) of DMAP for 8 h. The reaction solution was treated with saturated aqueous solution of  $\text{NH}_4\text{Cl}$ . The organic layer was separated and extracted with water, dried, filtered, and evaporated under reduced pressure. Chromatography ( $\text{Al}_2\text{O}_3$ , *n*-hexane/EtOAc, 10:1) gave 0.18 g (0.23 mmol, 65%) of a mixture of compounds **21** and **22** (**21/22** = 1.5) and 0.10 g (0.12 mmol, 35%) of a mixture of compounds **23** and **24** (**23/24** = 4.0). All compounds are solid. Compounds **21** and **22**. Anal. Calcd for  $\text{C}_{40}\text{H}_{58}\text{O}_{11}\text{Si}_2$ : C, 62.31; H, 7.58. Found: C, 62.44; H, 7.62; IR (nujol,  $\text{cm}^{-1}$ ): 3474, 1724, 1369, 1254; MS ( $m/z$ ) ESI: 772 ( $\text{M} + \text{H}$ ) $^+$ . (**21**);  $^1\text{H}$  NMR ( $\text{CD}_3\text{COCD}_3$ , 400 MHz)  $\delta$  7.60–7.64 (m, 2H, arom), 7.48–7.52 (m, 1H, arom), 7.37–7.46 (m, 2H, arom), 6.57 (s, 1H, H-10), 5.02 (dd, 1H, H-5,  $J$  = 0.5, 9.0 Hz), 4.68 (s, 2H, H-20), 4.55 (dd, 1H, H-7,  $J$  = 7.6, 9.6 Hz), 4.39 (d, 1H, H-2,  $J$  = 5.2 Hz), 3.50 (d, 1H, H-3,  $J$  = 5.2 Hz), 2.59–2.69 (m, 1H, H-6), 2.53 (d, 1H, H-14,  $J$  = 20.0 Hz), 2.29 (d, 1H, H-14,  $J$  = 20.0 Hz), 2.20 (s, 3H, Me), 2.11 (s, 3H, Me),

1.97 (s, 3H, Me), 1.76–1.88 (m, 1H, H-6), 1.78 (s, 3H, Me), 1.33 (s, 3H, Me), 1.20 (s, 3H, Me), 0.90–0.98 (m, 9H, 3 Me), 0.60–0.68 (m, 6H, 3  $\text{CH}_2$ ),  $-0.03$  (s, 9H, 3 Me);  $^{13}\text{C}$  NMR ( $\text{CD}_3\text{COCD}_3$ , 100 MHz)  $\delta$ : 204.4, 201.4, 173.5, 172.2, 155.1, 145.1, 144.0, 132.2, 131.6, 128.9, 120.8, 87.1, 87.0, 83.1, 80.4, 80.3, 79.4, 75.5, 64.3, 46.6, 45.7, 45.0, 41.3, 34.8, 24.3, 23.3, 21.3, 17.0, 13.1, 9.7, 8.4, 3.7. (**22**);  $^1\text{H}$  NMR ( $\text{CD}_3\text{COCD}_3$ , 100 MHz)  $\delta$  7.60–7.64 (m, 2H, arom), 7.48–7.52 (m, 1H, arom), 7.37–7.46 (m, 2H, arom), 6.54 (s, 1H, H-10), 5.02 (dd, 1H, H-5,  $J$  = 0.5, 9.0 Hz), 4.70 (s, 2H, H-20), 4.55 (dd, 1H, H-7,  $J$  = 7.6, 9.6 Hz), 3.90 (d, 1H, H-2,  $J$  = 5.2 Hz), 3.57 (d, 1H, H-3,  $J$  = 5.2 Hz), 3.07 (d, 1H, H-14,  $J$  = 20.4 Hz), 2.91 (d, 1H, H-14,  $J$  = 20.4 Hz), 2.59–2.69 (m, 1H, H $\alpha$ -6), 2.15 (s, 3H, Me), 2.14 (s, 3H, Me), 2.08 (s, 3H, Me), 1.76–1.88 (m, 1H, H $\beta$ -6), 1.65 (s, 3H, Me), 1.25 (s, 3H, Me), 0.98 (s, 3H, Me), 0.90–0.98 (m, 9H, 3 Me), 0.60–0.68 (m, 6H, 3  $\text{CH}_2$ ), 0.00 (s, 9H, 3 Me);  $^{13}\text{C}$  NMR ( $\text{CD}_3\text{COCD}_3$ , 100 MHz)  $\delta$  204.1, 201.7, 173.7, 172.2, 154.9, 144.8, 144.0, 132.2, 131.8, 128.3, 120.8, 89.1, 87.2, 82.9, 82.7, 80.1, 79.4, 75.4, 64.0, 46.9, 46.1, 45.1, 41.3, 34.9, 24.4, 23.3, 21.1, 12.8, 9.7, 8.3, 3.8. Compounds **23** and **24**. Anal. Calcd for  $\text{C}_{43}\text{H}_{66}\text{O}_{11}\text{Si}_3$ : C, 61.25; H, 7.89. Found: C, 61.03; H, 7.75; IR (nujol,  $\text{cm}^{-1}$ ): 1718, 1368, 1254, 1060, 842; MS ( $m/z$ ) ESI: 844 ( $\text{M} + \text{H}$ ) $^+$ . (**23**);  $^1\text{H}$  NMR ( $\text{CD}_3\text{COCD}_3$ , 400 MHz)  $\delta$  7.64–7.68 (m, 2H, arom), 7.46–7.50 (m, 1H, arom), 7.34–7.44 (m, 2H, arom), 6.43 (s, 1H, H-10), 5.02 (dd, 1H, H-5,  $J$  = 0.5, 9.2 Hz), 4.64 (s, 2H, H-20), 4.52 (dd, 1H, H-7,  $J$  = 8.0, 9.6 Hz), 4.48 (d, 1H, H-2,  $J$  = 5.6 Hz), 4.46 (s, 1H, H-14), 3.35 (d, 1H, H-3,  $J$  = 5.6 Hz), 2.56–2.66 (m, 1H, H $\alpha$ -6), 2.14 (s, 3H, Me), 2.02 (s, 3H, Me), 2.00 (s, 3H, Me), 1.78–1.88 (m, 1H, H $\beta$ -6), 1.78 (s, 3H, Me), 1.37 (s, 3H, Me), 1.15 (s, 3H, Me), 0.90–0.98 (m, 9H, 3 Me), 0.58–0.66 (m, 6H, 3  $\text{CH}_2$ ), 0.09 (s, 9H, 3 Me),  $-0.01$  (s, 9H, 3 Me);  $^{13}\text{C}$  NMR ( $\text{CD}_3\text{COCD}_3$ , 100 MHz)  $\delta$  206.2, 173.1, 172.3, 156.3, 154.4, 142.3, 137.4, 131.9, 131.4, 128.9, 122.0, 114.2, 91.2, 87.2, 82.8, 82.7, 80.1, 79.8, 75.5, 62.3, 45.8, 41.7, 41.4, 31.8, 24.4, 23.5, 21.6, 17.4, 13.5, 9.8, 8.5, 3.7, 3.1. (**24**);  $^1\text{H}$  NMR ( $\text{CD}_3\text{COCD}_3$ , 400 MHz)  $\delta$  7.64–7.68 (m, 2H, arom), 7.46–7.50 (m, 1H, arom), 7.34–7.44 (m, 2H, arom), 6.41 (s, 1H, H-10), 5.42 (s, 1H, H-14), 5.00 (dd, 1H,  $J$  = 0.5, 8.4 Hz), 4.67 (d, 1H, H-20,  $J$  = 8.4 Hz), 4.64 (d, 1H, H-20,  $J$  = 8.4 Hz), 4.52 (dd, 1H, H-7,  $J$  = 8.0, 9.6 Hz), 4.02 (d, 1H, H-2,  $J$  = 6.0 Hz), 3.40 (d, 1H, H-3,  $J$  = 6.0 Hz), 2.56–2.66 (m, 1H, H $\alpha$ -6), 2.12 (s, 3H, Me), 2.09 (s, 3H, Me), 2.06 (s, 3H, Me), 1.78–1.88 (m, 1H, H $\beta$ -6), 1.63 (s, 3H, Me), 1.42 (s, 3H, Me), 0.90–0.98 (m, 9H, 3 Me), 0.80 (s, 3H, Me), 0.58–0.66 (m, 6H, 3  $\text{CH}_2$ ), 0.34 (s, 9H, 3 Me), 0.03 (s, 9H, 3 Me);  $^{13}\text{C}$  NMR ( $\text{CD}_3\text{COCD}_3$ , 100 MHz)  $\delta$  205.9, 173.4, 172.2, 155.9, 146.1, 142.4, 137.1, 132.0, 131.7, 128.3, 121.7, 115.4, 93.1, 87.3, 82.7, 80.7, 80.0, 79.6, 75.4, 62.5, 45.5, 41.8, 41.3, 31.9, 24.6, 23.4, 21.5, 17.5, 13.2, 9.7, 8.5, 3.8, 2.8.

**4.1.10. Synthesis of 7,13-bis-TES-13,14-dehydro-1,2-[ $\alpha$ -( $\beta$ -O-TES)-benzylidene-acetal]-baccatin III (25); 7,13-bis-TES-13,14-dehydro-1,2-[ $\alpha$ -( $\beta$ -O-TES)-benzylidene-acetal]-baccatin III (26); 7-TES-13-oxo-1,2-[ $\alpha$ -( $\beta$ -O-TES)-benzylideneacetal]-baccatin III (27).** *Procedure A.* A solution of 0.35 g (0.49 mmol) of 7-TES-13-oxo-baccatin III **1**, 0.53 g (3.43 mmol) of DBU, 0.44 g (2.94 mmol) of  $\text{TESCl}$ , in 8.0 mL of  $\text{CH}_3\text{CN}$  was left at 20 °C for 5 h. After, the solution was treated with saturated solution of  $\text{NH}_4\text{Cl}$ . The organic layer was separated, the aqueous phase was

extracted with  $\text{CH}_2\text{Cl}_2$ . The organic phases were combined, dried, filtered, and evaporated under reduced pressure. The  $^1\text{H}$  NMR spectrum of the crude mixture ( $\text{CD}_3\text{COCD}_3$ ) showed a product distribution of **25/26**=1.2. Chromatography ( $\text{Al}_2\text{O}_3$ , cyclohexane/EtOAc, 97:3 to 95:5) gave 0.43 g (0.46 mmol, 93%) of the mixture of **25** and **26**. *Procedure B*: (i) Compound **1** (0.14 g, 0.2 mmol) was dissolved in THF (5.0 mL) and the solution was cooled to  $-70^\circ\text{C}$ .  $t\text{BuOK}$  (1.0 M in THF, 0.5 mmol) was added and the reaction mixture stirred for 15 min at  $-70^\circ\text{C}$ , then  $\text{TESCl}$  (0.07 mL, 0.40 mmol) was added. After 45 min the reaction was quenched with saturated aqueous solution of  $\text{NH}_4\text{Cl}$  (8.0 mL) and extracted with EtOAc, dried, and the solvent was evaporated. The crude mixture was purified by chromatography ( $\text{Al}_2\text{O}_3$ , *n*-hexane/EtOAc, 10:1) to afford compounds **27** (0.13 g, 0.16 mmol, 80%) and **25** (0.04 g, 0.04 mmol, 20%). Attempted purification of 0.20 g of the 80:20 mixture of **25/27** (cyclohexane/EtOAc, 9:1) caused a partial solvolysis of **25** and **27** affording the silyl enol ether **28** and the reagent **1**. Final product distribution was **1/27/28**=31:49:20. (ii): Compound **1** (0.14 g, 0.2 mmol) was dissolved in THF (4.0 mL) and the solution was cooled to  $-60^\circ\text{C}$ .  $t\text{BuOK}$  (1.0 M in THF, 1.0 mmol) was added and the reaction mixture stirred for 15 min at  $-60^\circ\text{C}$ , then  $\text{TESCl}$  (0.21 mL, 1.2 mmol) was added. After 1 h the reaction was quenched with saturated aqueous solution of  $\text{NH}_4\text{Cl}$  and extracted with EtOAc, dried, and the solvent was evaporated. The crude was purified by chromatography ( $\text{Al}_2\text{O}_3$ , *n*-hexane/EtOAc, 10:1) to obtain compound **25** (0.17 g, 0.19 mmol, 94%). Compounds **25** and **26**. Anal. Calcd for  $\text{C}_{49}\text{H}_{78}\text{O}_{11}\text{Si}_3$ : C, 63.46; H, 8.48. Found: C, 63.67; H, 8.55; IR (nujol,  $\text{cm}^{-1}$ ): 1735, 1719, 1376, 1232. (**25**):  $[\alpha]_{\text{D}}^{20} + 8.7$  (*c* 0.40,  $\text{CH}_3\text{COCH}_3$ ); MS (*m/z*) ESI: 928 ( $\text{M} + \text{H}$ ) $^+$ ;  $^1\text{H}$  NMR ( $\text{CD}_3\text{COCD}_3$ , 400 MHz)  $\delta$ : 7.68–7.73 (m, 2H), 7.40–7.44 (m, 3H, arom), 6.45 (s, 1H, H-10), 5.05 (dd, 1H, H-5 *J*=0.9, 7.7 Hz), 4.64–4.68 (m, 2H), 4.52 (dd, 1H, *J*=7.0, 10.2 Hz), 4.50 (1H, H-2, *J*=5.9 Hz), 4.46 (s, 1H), 3.37 (d, 1H, H-3, *J*=5.9 Hz), 2.57–2.68 (m, 1H, H $\alpha$ -6), 2.13 (s, 3H, Me), 2.07 (s, 3H, Me), 2.03 (s, 3H, Me), 1.80–1.90 (m, 1H, H $\beta$ -6), 1.79 (s, 3H, Me), 1.37 (s, 3H, Me), 1.17 (s, 3H, Me), 0.85–1.00 (m, 18H, 9  $\text{CH}_2$ ), 0.50–0.70 (m, 27H, 9 Me);  $^{13}\text{C}$  NMR ( $\text{CD}_3\text{COCD}_3$ , 100 MHz)  $\delta$ : 202.9, 169.8, 168.9, 153.0, 143.1, 138.9, 134.0, 128.6, 128.0, 125.7, 118.6, 110.9, 89.7, 83.9, 79.6, 77.7, 76.8, 76.6, 72.2, 59.3, 42.3, 38.6, 38.1, 28.3, 21.2, 20.3, 18.5, 14.0, 10.1, 6.5, 6.3, 6.2, 5.3, 5.2, 4.8. (**26**):  $^1\text{H}$  NMR ( $\text{CD}_3\text{COCD}_3$ , 400 MHz)  $\delta$ : 7.48–7.53 (m, 2H, arom), 7.40–7.44 (m, 3H, arom), 6.40 (s, 1H, H-10), 5.36 (s, 1H, H-14), 4.98 (dd, 1H, H-5, *J*=0.9, 7.7 Hz), 4.64–4.68 (m, 2H, H-20), 4.52 (dd, 1H, H-7, *J*=9.2, 6.8 Hz), 3.97 (d, 1H, H-2, *J*=6.0 Hz), 3.40 (d, 1H, H-3, *J*=6.0 Hz), 2.57–2.68 (m, 1H, H $\alpha$ -6), 2.14 (s, 3H, Me), 2.07 (s, 3H, Me), 2.02 (s, 3H, Me), 1.76–1.86 (m, 1H, H $\beta$ -6), 1.62 (s, 3H, Me), 1.42 (s, 3H, Me), 0.85–1.00 (m, 27H, 9 Me), 0.80 (s, 3H, Me), 0.50–0.70 (m, 18H, 9  $\text{CH}_2$ );  $^{13}\text{C}$  NMR ( $\text{CD}_3\text{COCD}_3$ , 100 MHz)  $\delta$ : 202.5, 170.1, 168.9, 152.6, 142.3, 139.0, 133.9, 128.7, 128.4, 125.1, 118.5, 112.9, 87.1, 84.0, 79.4, 79.0, 76.7, 76.4, 72.1, 59.2, 42.4, 38.6, 38.1, 28.4, 21.3, 20.2, 18.4, 14.2, 9.9, 6.5, 5.3. (**27**):  $[\alpha]_{\text{D}}^{20} + 8.8$  (*c* 0.40,  $\text{CH}_3\text{COCH}_3$ ); IR (nujol,  $\text{cm}^{-1}$ ): 3470, 1727, 1371, 1250; MS (*m/z*) ESI: 814 ( $\text{M} + \text{H}$ ) $^+$ ;  $^1\text{H}$  NMR ( $\text{CDCl}_3$ , 400 MHz)  $\delta$ : 7.54–7.58 (m, 2H, arom), 7.32–7.35 (m, 3H, arom), 6.55 (s, 1H, H-10), 4.99 (dd, 1H, *J*=8.8, 0.9 Hz), 4.75 (s, 2H, H-20), 4.49 (dd, 1H,

H-7, *J*=7.0, 9.6 Hz), 4.35 (d, 1H, H-2, *J*=6.9 Hz), 3.45 (d, 1H, H-3, *J*=6.9 Hz), 2.56–2.64 (m, 1H, H $\alpha$ -6), 2.26–2.32 (m, 2H, H-14), 2.23 (s, 3H, Me), 2.14 (s, 3H, Me), 2.01 (s, 3H, Me), 1.87–1.95 (m, 1H, H $\beta$ -6), 1.79 (s, 3H, Me), 1.34 (s, 3H, Me), 1.22 (s, 3H, Me), 0.90–1.03 (m, 18H, 6 Me), 0.40–0.85 (m, 12H, 6  $\text{CH}_2$ );  $^{13}\text{C}$  NMR ( $\text{CDCl}_3$ , 100 MHz)  $\delta$ : 201.1, 198.0, 170.2, 168.9, 151.7, 142.1, 140.7, 128.6, 128.1, 125.6, 117.5, 85.7, 83.9, 79.8, 77.4, 77.0, 76.2, 72.2, 61.0, 43.4, 42.4, 41.8, 38.1, 31.5, 21.0, 20.0, 18.0, 13.7, 9.7, 6.5, 6.3, 5.9, 5.3. Anal. Calcd for  $\text{C}_{43}\text{H}_{64}\text{O}_{11}\text{Si}_2$ : C, 63.51; H, 7.93. Found: C, 63.74; H, 8.04.

**4.1.11. Desilylation of compounds 23 and 24 into 7-TES-13-TMS-13,14-dehydro-baccatin III (3)**. A mixture of **23/24**=0.89 (0.20 g, 0.24 mmol) was dissolved in 4.0 mL of  $\text{CH}_2\text{Cl}_2$  at  $20^\circ\text{C}$ , then 0.03 g (0.02 mmol) of PTSA was added. After 20 min the reaction solution was treated with saturated aqueous solution of  $\text{NH}_4\text{Cl}$ . The organic layer was separated and extracted with water, dried, filtered, and evaporated under reduced pressure. Chromatography ( $\text{SiO}_2$ , *n*-hexane/ $\text{CH}_2\text{Cl}_2$ /EtOAc, 14:6:3) gave compound **3** as a white solid (0.18 g, 0.23 mmol, 95%). IR (nujol,  $\text{cm}^{-1}$ ): 1721, 1255, 1238, 1107, 1068;  $[\alpha]_{\text{D}}^{20} - 44.0$  (*c* 1.14,  $\text{CHCl}_3$ ); MS (*m/z*) ESI: 772 ( $\text{M} + \text{H}$ ) $^+$ ;  $^1\text{H}$  NMR ( $\text{CDCl}_3$ , 400 MHz)  $\delta$ : 8.08 (m, 2H, arom), 7.56–7.62 (m, 1H, arom), 7.44–7.50 (m, 2H, arom), 6.41 (s, 1H, H-10), 5.76 (d, 1H, H-2, *J*=7.2 Hz), 4.97 (dd, 1H, H-5, *J*=9.6, 0.5 Hz), 4.73 (s, 1H, H-14), 4.44 (dd, 1H, H-7, *J*=6.9, 10.5 Hz), 4.29 (d, 1H, H-20, *J*=8.4 Hz), 4.14 (d, 1H, H-20, *J*=8.4 Hz), 3.71 (d, 1H, H-3, *J*=7.2 Hz), 2.46–2.56 (m, 1H, H $\alpha$ -6), 2.19 (s, 3H, Me), 2.18 (s, 3H, Me), 2.05 (s, 3H, Me), 1.82–1.90 (m, 1H, H $\beta$ -6), 1.69 (s, 3H, Me), 1.26 (s, 3H, Me), 1.12 (s, 3H, Me), 0.88–0.95 (m, 9H, 3 Me), 0.52–0.60 (m, 6H, 6  $\text{CH}_2$ ), 0.25 (s, 9H, 3 Me);  $^{13}\text{C}$  NMR ( $\text{CDCl}_3$ , 100 MHz)  $\delta$ : 202.2, 170.2, 169.6, 166.9, 153.5, 138.0, 135.2, 133.8, 130.3, 129.7, 128.8, 110.6, 84.2, 81.4, 80.7, 76.5, 76.2, 73.6, 72.4, 58.3, 45.1, 41.0, 37.4, 29.0, 21.9, 21.3, 19.1, 14.2, 10.3, 7.0, 5.5, 0.6. Anal. Calcd for  $\text{C}_{40}\text{H}_{58}\text{O}_{11}\text{Si}_2$ : C, 62.31; H, 7.58. Found: C, 62.50; H, 7.68.

**4.1.12. Desilylation of compounds 25 and 26 into 7, 13-bis-TES-13,14-dehydro-baccatin III (28)**. A mixture of **25/26**=1.25 (0.25 g, 0.27 mmol) was dissolved in 4.0 mL of  $\text{CH}_2\text{Cl}_2$  at  $20^\circ\text{C}$  then 0.03 g (0.02 mmol) of PTSA was added. After 12 h the reaction was treated with saturated aqueous solution of  $\text{NH}_4\text{Cl}$ . The organic layer was separated and extracted with water, dried, filtered, and evaporated under reduced pressure. Chromatography ( $\text{SiO}_2$ , *n*-hexane/ $\text{CH}_2\text{Cl}_2$ /EtOAc, 14:6:3) gave compound **28** (0.20 g, 0.25 mmol, 93%) as a white solid. (**28**): IR (nujol,  $\text{cm}^{-1}$ ): 3483, 1739, 1722, 1704, 1376, 1242;  $[\alpha]_{\text{D}}^{20} - 6.0$  (*c* 1.0,  $\text{CHCl}_3$ ); MS (*m/z*) ESI: 814 ( $\text{M} + \text{H}$ ) $^+$ ;  $^1\text{H}$  NMR ( $\text{CDCl}_3$ , 400 MHz)  $\delta$ : 8.06–8.10 (m, 2H, arom), 7.54–7.60 (m, 1H, arom), 7.40–7.46 (m, 2H, arom), 6.42 (s, 1H, H-10), 5.75 (d, 1H, H-2, *J*=7.3 Hz), 4.95 (dd, 1H, H-5, *J*=0.9, 9.7 Hz), 4.73 (s, 1H, H-14), 4.43 (dd, 1H, H-7, *J*=6.9, 10.0 Hz), 4.27 (d, 1H, H-20, *J*=8.0 Hz), 4.13 (d, 1H, H-20, *J*=8.0 Hz), 3.71 (d, 1H, H-3, *J*=7.3 Hz), 2.44–2.53 (m, 1H, H $\alpha$ -6, *J*=7.3, 9.7, 14.5 Hz), 2.19 (s, 3H, Me), 2.17 (s, 3H, Me), 2.05 (s, 3H, Me), 1.80–1.88 (m, 1H, H $\beta$ -6), 1.67 (s, 3H, Me), 1.24 (s, 3H, Me), 1.10 (s, 3H, Me), 0.88–0.96 (m, 18H, 3 Me), 0.54–0.78 (m, 12H, 3  $\text{CH}_2$ );  $^{13}\text{C}$  NMR ( $\text{CDCl}_3$ , 100 MHz)  $\delta$ : 202.1, 170.1, 169.6, 166.9, 153.5, 137.9, 135.1, 133.7,



130.2, 129.7, 128.8, 110.6, 84.4, 81.4, 80.7, 76.5, 76.2, 73.8, 72.3, 58.3, 45.2, 40.9, 37.4, 28.7, 21.9, 21.2, 19.2, 14.0, 10.3, 7.0, 6.9, 5.5, 5.2. Anal. Calcd for  $C_{43}H_{64}O_{11}Si_2$ : C, 63.51; H, 7.93. Found: C, 63.29; H, 7.84.

#### 4.1.13. 7-TES-13-TIPS-13,14-dehydro-baccatin III (29).

Compound **1** (0.57 g, 0.81 mmol) was dissolved in 4:1 THF/DMPU mixture (21.0 mL) and the solution was cooled to  $-78^\circ\text{C}$ .  $t\text{-BuOK}$  (1.0 M in THF, 0.5 mmol) was added and the reaction mixture stirred for 15 min at  $-70^\circ\text{C}$ , then TIPSCl (0.06 mL, 0.34 mmol) was added. After 3.0 h the reaction was quenched with saturated  $\text{NH}_4\text{Cl}$  (8.0 mL) and extracted with EtOAc, dried, and the solvent was evaporated. The crude mixture was purified by chromatography ( $\text{SiO}_2$ , *n*-hexane/EtOAc/ $\text{Et}_2\text{O}$ , 18:6:4) gave the reagent **1** (0.17 g, 0.31 mmol, 31%) and compound **29** (0.38 g, 0.45 mmol, 55%) as a white solid. (**29**): IR (nujol,  $\text{cm}^{-1}$ ): 3483, 1725, 1376, 1239;  $[\alpha]_{\text{D}}^{20} -21.0$  (*c* 0.9,  $\text{CHCl}_3$ ); MS (*m/z*) ESI: 856 ( $\text{M}+\text{H}^+$ );  $^1\text{H}$  NMR ( $\text{CDCl}_3$ , 400 MHz)  $\delta$ : 8.05–8.10 (m, 2H, arom), 7.57–7.61 (m, 1H, arom), 7.44–7.49 (m, 2H, arom), 6.40 (s, 1H, H-10), 5.77 (d, 1H, H-2,  $J=7.6$  Hz), 4.95 (dd, 1H, H-5,  $J=1.2$ , 9.5 Hz), 4.82 (s, 1H, H-14), 4.47 (dd, 1H, H-7,  $J=6.4$ , 10.0 Hz), 4.28 (d, 1H, H-20,  $J=8.4$  Hz), 4.17 (d, 1H,  $J=8.4$  Hz), 3.74 (d, 1H, H-3,  $J=7.6$  Hz), 2.45–2.54 (ddd, 1H, H $\alpha$ -6,  $J=7.6$ , 9.5, 14.5 Hz), 2.22 (s, 3H, Me), 2.19 (s, 3H, Me), 2.10 (s, 3H, Me), 1.84–1.92 (m, 1H, H $\beta$ -6), 1.70 (s, 3H, Me), 1.25 (s, 3H, Me), 1.15 (s, 3H, Me), 1.05–1.15 (m, 21H), 0.90–0.94 (t, 9H, 2 Me), 0.54–0.72 (m, 6H, 3  $\text{CH}_2$ );  $^{13}\text{C}$  NMR ( $\text{CDCl}_3$ , 100 MHz)  $\delta$ : 201.7, 170.0, 169.3, 166.7, 153.5, 137.8, 134.8, 133.6, 130.2, 129.7, 128.7, 110.6, 84.4, 81.9, 80.8, 76.5, 76.2, 74.2, 72.4, 58.4, 45.6, 41.0, 37.5, 28.5, 22.3, 21.4, 19.8, 18.5, 18.4, 14.2, 13.0, 10.7, 7.2, 5.7. Anal. Calcd for  $C_{46}H_{70}O_{11}Si_2$ : C, 64.60; H, 8.25 Found: C, 64.45; H, 8.17.

#### 4.1.14. 7-TES-13-oxo-14 $\beta$ -azido-baccatin III (4).

A solution of 0.21 g (0.27 mmol) of **3** in 5.0 mL of  $\text{CH}_3\text{CN}$  were added 0.08 g of  $\text{NaN}_3$  (1.2 mmol) and 0.45 g (0.81 mmol) of CAN under nitrogen stream at  $0^\circ\text{C}$ . The mixture was stirred for 1.0 h, diluted with 7.0 mL of  $\text{H}_2\text{O}$  and extracted with 5.0 mL of  $\text{Et}_2\text{O}$ . The organic phase was dried, the solvent evaporated and the residue was chromatographed ( $\text{SiO}_2$ , cyclohexane/EtOAc/ $\text{Et}_2\text{O}$ , 8:1:1) giving 0.19 g of compound **4** (0.26 mmol, 95%) as a white solid. In a similar experiment compound **29** (0.07 g, 0.08 mmol) was reacted with 0.06 g of  $\text{NaN}_3$  (0.57 mmol) and 0.49 g of CAN (0.9 mmol) to afford compound **4** (0.03 g, 0.04 mmol, 55%).

#### 4.1.15. 7-TES-13-oxo-14 $\beta$ -amino-baccatin III (30).

$\text{PPh}_3$  (0.11 g, 0.43 mmol) was added to a solution of 0.29 g (0.39 mmol) of **4** in 11.7 mL of a  $\text{CH}_3\text{CN}/\text{H}_2\text{O}=9:1$  mixed solvent. The reaction was cooled at  $5^\circ\text{C}$ , and after 18 h was evaporated under reduced pressure. Chromatography of the residue ( $\text{SiO}_2$ , *n*-hexane/EtOAc/ $\text{Et}_2\text{O}$ , 1.8:0.7:0.3) afforded 0.24 g (0.34 mmol, 88%) of **30** as a white solid. IR (KBr,  $\text{cm}^{-1}$ ): 3396, 3204, 2956, 2878, 2255, 1728, 1452, 1370, 1105;  $[\alpha]_{\text{D}}^{20} +18.1$  (*c* 0.5,  $\text{CH}_2\text{Cl}_2$ ); MS (*m/z*) ESI: 715 ( $\text{M}+\text{H}^+$ );  $^1\text{H}$  NMR ( $\text{CDCl}_3$ , 400 MHz)  $\delta$  7.99–8.01 (m, 2H, arom), 7.61–7.66 (m, 1H, arom), 7.43–7.45 (m, 2H, arom), 6.50 (s, 1H, H-10), 5.86 (d, 1H, H-2,  $J=6.8$  Hz), 4.89 (dd, 1H, H-5,  $J=2.0$ , 9.6 Hz), 4.47 (dd, 1H, H-7,  $J=$

6.4, 10.4 Hz), 4.30 (d, 1H, H-20,  $J=8.8$  Hz), 4.24 (d, 1H, H-20,  $J=8.8$  Hz), 3.84 (d, 1H, H-3,  $J=6.8$  Hz), 3.57 (s, 1H, H-14), 2.52 (ddd, 1H, H $\alpha$ -6,  $J=6.4$ , 9.2, 14.0 Hz), 2.21 (s, 3H, Me), 2.19 (s, 3H, Me), 2.12 (s, 3H, Me), 1.90 (ddd, 1H, H $\beta$ -6,  $J=2.0$ , 11.2, 14.0 Hz), 1.73 (s, 3H, Me), 1.27 (s, 3H, Me), 0.93 (m, 9H, 3 Me), 0.84 (s, 3H, Me), 0.55–0.62 (m, 6H, 3  $\text{CH}_2$ );  $^{13}\text{C}$  NMR (100 MHz,  $\text{CDCl}_3$ )  $\delta$  201.5, 200.2, 169.9, 169.2, 165.4, 151.7, 138.1, 133.7, 129.9, 129.8, 128.9, 84.1, 81.4, 76.4, 75.5, 73.4, 72.9, 72.4, 59.1, 57.9, 45.4, 43.1, 37.3, 33.1, 21.8, 21.0, 19.9, 14.1, 10.1, 6.9, 5.5. Anal. Calcd  $C_{37}H_{51}NO_{11}Si$ : C, 62.25; H, 7.20; N, 1.96. Found: C, 62.33; H, 7.29; N, 1.90.

#### 4.1.16. 7-BOC-13-oxo-14 $\beta$ -amino-baccatin III (31).

$\text{PPh}_3$  (0.09 g, 0.34 mmol) was added to a solution of 0.20 g (0.27 mmol) of **5** in 7.5 mL of a mixture of acetonitrile/water =7:1. After 2 h the reaction mixture was concentrated under reduced pressure. Chromatography of the residue ( $\text{SiO}_2$ , *n*-hexane/EtOAc, 1.4:1.0) yielded 0.14 g (0.21 mmol, 77%) of **31** as a white solid. IR (KBr,  $\text{cm}^{-1}$ ): 3053, 2960, 1726, 1478, 1434, 1090;  $[\alpha]_{\text{D}}^{20} +31.7$  (*c* 0.4,  $\text{CH}_2\text{Cl}_2$ ); MS (*m/z*) ESI: 701 ( $\text{M}+\text{H}^+$ );  $^1\text{H}$  NMR ( $\text{CDCl}_3$ , 400 MHz)  $\delta$  7.8–8.15 (m, 2H, arom), 7.58–7.63 (m, 1H, arom), 7.44–7.50 (m, 2H, arom), 6.55 (s, 1H, H-10), 5.86 (d, 1H, H-2,  $J=6.8$  Hz), 5.40 (dd, 1H, H-7,  $J=10.8$ , 7.0 Hz), 4.94 (dd, 1H, H-5,  $J=2.1$ , 9.6 Hz), 4.33 (d, 1H, H-20,  $J=8.4$  Hz), 4.26 (d, 1H, H-20,  $J=8.4$  Hz), 4.01 (d, 1H, H-3,  $J=6.4$  Hz), 3.58 (s, 1H, H-14), 2.61 (ddd, 1H, H $\alpha$ -6,  $J=7.0$ , 9.6, 14.4 Hz), 2.22 (s, 3H, Me), 2.19 (s, 3H, Me), 2.14 (s, 3H, Me), 1.98 (ddd, 1H, H $\beta$ -6,  $J=2.1$ , 10.8, 14.4 Hz), 1.84 (s, 3H, Me), 1.48 (s, 9H, 3 Me), 1.25 (s, 3H, Me), 0.89 (s, 3H, Me);  $^{13}\text{C}$  NMR ( $\text{CDCl}_3$ , 100 MHz)  $\delta$  201.2, 200.1, 170.0, 168.0, 165.3, 151.8, 150.5, 138.2, 133.9, 130.0, 129.2, 129.1, 83.6, 82.4, 80.7, 76.9, 75.6, 75.4, 74.6, 72.4, 65.0, 56.2, 45.1, 42.9, 33.7, 33.7, 26.7, 21.9, 20.5, 19.1, 14.4, 10.7. Anal. Calcd  $C_{36}H_{45}NO_{13}$ : C, 61.79; H, 6.48; N, 2.00. Found: C, 61.86; H, 6.42; N, 2.12.

#### 4.1.17. 7-TES-13-oxo-14 $\beta$ -amino-baccatin III 14,1-carbamate (32).

A 1.93 M solution of phosgene in toluene (0.32 mL, 0.62 mmol) and 0.1 mL (1.20 mmol) of pyridine were added under stirring to a solution of 0.44 g (0.62 mmol) of **30** in 6.0 mL of  $\text{CH}_2\text{Cl}_2$  at  $-78^\circ\text{C}$ . After 1 h the reaction mixture was quenched by addition of 10.0 mL of water and extracted with 10.0 mL of  $\text{CH}_2\text{Cl}_2$ ; the organic phase was washed with brine, dried, filtered, and evaporated under reduced pressure. Chromatography ( $\text{SiO}_2$ , *n*-hexane/EtOAc/ $\text{Et}_2\text{O}$ , 1.8:0.7:0.3) gave 0.39 g (0.53 mmol, 86%) of **32** as a white solid. IR (KBr,  $\text{cm}^{-1}$ ): 3342, 2956, 1732, 1452, 1238, 1090;  $[\alpha]_{\text{D}}^{20} +28.5$  (*c* 1.0,  $\text{CH}_2\text{Cl}_2$ ); MS (*m/z*) ESI: 741 ( $\text{M}+\text{H}^+$ );  $^1\text{H}$  NMR ( $\text{CDCl}_3$ , 400 MHz)  $\delta$  7.96–7.98 (m, 2H, arom), 7.58–7.61 (m, 1H, arom), 7.42–7.45 (m, 2H, arom), 6.48 (s, 1H, H-10), 6.06 (d, 1H, H-2,  $J=6.9$  Hz), 6.02 (s, 1H, N-H), 4.90 (dd, 1H, H-5,  $J=1.9$ , 9.5 Hz), 4.46 (dd, 1H, H-7,  $J=10.7$ , 6.5 Hz), 4.32 (d, 1H, H-20,  $J=8.8$  Hz), 4.23 (d, 1H, H-20,  $J=8.8$  Hz), 4.17 (s, 1H, H-14), 3.83 (d, 1H, H-3,  $J=6.9$  Hz), 2.52 (ddd, 1H, H $\alpha$ -6,  $J=6.5$ , 9.7, 14.0 Hz), 2.22 (s, 3H, Me), 2.20 (s, 3H, Me), 2.15 (s, 3H, Me), 1.92 (ddd, 1H, H $\beta$ -6,  $J=1.9$ , 10.8, 14.0 Hz), 1.73 (s, 3H, Me), 1.34 (s, 3H, Me), 1.14 (s, 3H, Me), 0.91–0.95 (m, 9H, 3 Me), 0.58–0.62 (m, 6H, 3  $\text{CH}_2$ );  $^{13}\text{C}$  NMR ( $\text{CDCl}_3$ , 100 MHz)  $\delta$  199.3, 195.6, 170.1, 168.9, 164.6, 155.7, 151.1, 138.9, 134.2, 129.9, 129.0,

128.4, 86.2, 84.2, 80.9, 76.3, 74.9, 72.3, 69.7, 59.3, 59.2, 45.4, 42.6, 37.3, 32.9, 22.1, 21.1, 19.8, 14.2, 10.4, 7.2, 5.7. Anal. Calcd C<sub>38</sub>H<sub>49</sub>NO<sub>12</sub>Si: C, 61.69; H, 6.68; N, 1.89. Found: C, 61.76; H, 6.75; N, 1.81.

**4.1.18. 13 $\alpha$ -OH and 13 $\beta$ -OH epimers of 7-TES-14 $\beta$ -amino-baccatin III 14,1-carbamate (13 $\alpha$ -33 and 13 $\beta$ -34).** Sodium borohydride (0.18 g, 4.5 mmol) was added, under stirring, to a solution of 0.22 g (0.30 mmol) of **32** in 8.0 mL of ethanol at  $-40^{\circ}\text{C}$ . The temperature was raised to  $-18^{\circ}\text{C}$ , then an additional amount of sodium borohydride (0.12 g, 3.0 mmol) was added. After 18 h, the reaction mixture was quenched by addition of 2.0 mL of acetic acid and extracted with 10.0 mL of EtOAc. The organic phase was dried, filtered, and evaporated under reduced pressure. The  $^1\text{H}$  NMR spectrum of the residue showed the presence of 7-TES-14 $\beta$ -amino-baccatin III 14,1-carbamate as a mixture of epimers 13 $\alpha$ -**33** and 13 $\beta$ -**34** in an  $\alpha/\beta$  ratio of 1.6:1. Chromatography (SiO<sub>2</sub>, CH<sub>2</sub>Cl<sub>2</sub>/EtOAc, 1.0:0.9) yielded 0.12 g of 13 $\alpha$ -**33** (0.17 mmol, 56%) and 0.08 g of 13 $\beta$ -**34** (0.11 mmol, 35%) as solids. (13 $\alpha$ -**33**): IR (KBr, cm<sup>-1</sup>): 3364, 2955, 1731, 1452, 1372, 1089; [ $\alpha$ ]<sub>D</sub><sup>20</sup> +16.2 (c 0.7, CH<sub>2</sub>Cl<sub>2</sub>); MS (*m/z*) ESI: 742 (M+H)<sup>+</sup>;  $^1\text{H}$  NMR (CDCl<sub>3</sub>, 400 MHz)  $\delta$  7.98–8.01 (m, 2H, arom), 7.58–7.61 (m, 1H, arom), 7.41–7.45 (m, 2H, arom), 6.73 (s, 1H, N-H), 6.42 (s, 1H, H-10), 5.98 (d, 1H, H-2,  $J=7.2$  Hz), 4.93 (dd, 1H, H-5,  $J=2.0, 9.5$  Hz), 4.66 (m, 1H, H-13), 4.44 (dd, 1H, H-7,  $J=7.2, 10.0$  Hz), 4.23 (d, 1H, H-20,  $J=8.4$  Hz), 4.15 (d, 1H, H-20,  $J=8.4$  Hz), 3.98 (d, 1H, H-14,  $J=6.0$  Hz), 3.75 (d, 1H, H-3,  $J=7.2$  Hz), 3.66 (b, 1H, OH), 2.52 (ddd, 1H, H $\alpha$ -6,  $J=7.2, 9.5$  Hz, 13.5 Hz), 2.19 (s, 3H, Me), 2.17 (s, 3H, Me), 2.15 (s, 3H, Me), 1.88 (ddd, 1H, H $\beta$ -6,  $J=2.0, 10.0, 13.5$  Hz), 1.70 (s, 3H, Me), 1.26 (s, 3H, Me), 1.08 (s, 3H, Me), 0.90–0.96 (m, 9H, 3 Me), 0.55–0.59 (m, 6H, 3 CH<sub>2</sub>);  $^{13}\text{C}$  NMR (CDCl<sub>3</sub>, 100 MHz)  $\delta$  201.3, 170.3, 169.2, 165.3, 158.2, 143.1, 134.0, 132.5, 129.9, 128.9, 128.8, 88.9, 84.3, 80.7, 75.4, 73.4, 72.3, 71.1, 61.1, 58.9, 46.5, 42.2, 37.4, 30.1, 26.2, 22.6, 22.1, 21.3, 15.1, 10.6, 7.2, 5.7. Anal. Calcd C<sub>38</sub>H<sub>51</sub>NO<sub>12</sub>Si: C, 61.52; H, 6.93; N, 1.89. Found: C, 61.38; H, 6.84; N, 1.85. (13 $\beta$ -**34**): IR (KBr, cm<sup>-1</sup>): 3360, 1734; MS (*m/z*) ESI: 743 (M+H)<sup>+</sup>;  $^1\text{H}$  NMR (CDCl<sub>3</sub>, 400 MHz)  $\delta$  7.97–8.01 (m, 2H, arom), 7.60–7.64 (m, 1H, arom), 7.44–7.48 (m, 2H, arom), 7.00 (s, 1H, N-H), 6.38 (s, 1H, H-10), 5.98 (d, 1H, H-2,  $J=6.8$  Hz), 4.82 (dd, 1H, H-5,  $J=2.4, 8.0$  Hz), 4.38 (dd, 1H, H-7,  $J=6.8, 10.4$  Hz), 4.25 (m, 1H, H-13), 4.23 (d, 1H, H-20,  $J=8.4$  Hz), 4.12 (d, 1H, H-20,  $J=8.4$  Hz), 3.98 (d, 1H, H-14,  $J=5.9$  Hz), 3.62 (d, 1H, H-3,  $J=6.8$  Hz), 2.50 (ddd, 1H, H $\alpha$ -6,  $J=8.0, 6.8, 13.6$  Hz), 2.19 (s, 3H, Me), 2.17 (s, 3H, Me), 1.98 (s, 3H, Me), 1.87 (ddd, 1H, H $\beta$ -6,  $J=2.4, 10.4, 13.6$  Hz), 1.68 (s, 3H, Me), 1.30 (s, 3H, Me), 1.28 (s, 3H, Me), 0.89–0.93 (m, 9H, 3 Me), 0.55–0.68 (m, 6H, 3 CH<sub>2</sub>);  $^{13}\text{C}$  NMR (CDCl<sub>3</sub>, 100 MHz)  $\delta$  200.7, 169.9, 169.1, 165.1, 158.9, 141.0, 138.1, 134.0, 129.9, 129.0, 128.9, 93.4, 84.3, 81.1, 76.3, 75.5, 72.1, 70.0, 68.2, 59.2, 54.0, 46.1, 41.4, 30.8, 30.1, 22.0, 21.4, 21.2, 20.2, 10.4, 7.2, 5.7. Anal. Calcd C<sub>38</sub>H<sub>51</sub>NO<sub>12</sub>Si: C, 61.52; H, 6.93; N, 1.89. Found: C, 61.70; H, 7.01; N, 1.88.

**4.1.19. 13 $\alpha$ -OH and 13 $\beta$ -OH epimers of 7-TES-14 $\beta$ -azido-baccatin III (13 $\alpha$ -37 and 13 $\beta$ -38).** Sodium borohydride (0.47 g, 12.5 mmol) was added at  $-40^{\circ}\text{C}$  to a solution of 0.46 g (0.62 mmol) of **4** in 0.7 mL of THF and 12.0 mL of EtOH under stirring. The temperature was raised

to  $-30^{\circ}\text{C}$ . After 4 days, at  $-30^{\circ}\text{C}$ , the reaction was quenched by addition of 2.0 mL of acetic acid and extracted three times with 15.0 mL of EtOAc. The organic phase was dried, filtered and evaporated under reduced pressure.  $^1\text{H}$  NMR spectrum of the residue showed the presence of 7-TES-14 $\beta$ -azido-baccatin III (13 $\alpha$ -**37**) and its 13 $\beta$  epimer (13 $\beta$ -**38**) in an  $\alpha/\beta = 91:9$  ratio. Chromatography (SiO<sub>2</sub>, *n*-hexane/EtOAc, 2.1:1.0) afforded 0.35 g of 13 $\alpha$ -**37** (0.47 mmol, 76%) and 0.04 g of 13 $\beta$ -**38** (0.06 mmol, 9%) as white solids. (13 $\alpha$ -**37**): IR (KBr, cm<sup>-1</sup>): 3493, 2956, 2881, 2112, 1728, 1371, 1233; [ $\alpha$ ]<sub>D</sub><sup>20</sup> +20.0 (c 0.8, CH<sub>2</sub>Cl<sub>2</sub>); MS (*m/z*) ESI: 743 (M+H)<sup>+</sup>;  $^1\text{H}$  NMR (CDCl<sub>3</sub>, 400 MHz)  $\delta$  8.07–8.1 (m, 2H, arom), 7.58–7.62 (m, 1H, arom), 7.44–7.50 (m, 2H, arom), 6.41 (s, 1H, H-10), 5.82 (d, 1H, H-2,  $J=7.1$  Hz), 4.97 (dd, 1H, H-5,  $J=1.9, 9.5$  Hz), 4.80 (m, 1H, H-13), 4.46 (dd, 1H, H-7,  $J=6.5, 10.4$  Hz), 4.33 (d, 1H, H-20,  $J=8.4$  Hz), 4.23 (d, 1H, H-20,  $J=8.4$  Hz), 3.98 (d, 1H, H-14,  $J=7.3$  Hz), 3.82 (d, 1H, H-3,  $J=7.1$  Hz), 3.00 (s, 1H, OH), 2.82 (b, 1H, OH), 2.53 (ddd, 1H, H $\alpha$ -6,  $J=6.5, 9.5, 14.2$  Hz), 2.34 (s, 3H, Me), 2.20 (s, 3H, Me), 2.18 (s, 3H, Me), 1.90 (ddd, 1H, H $\beta$ -6,  $J=1.9$  Hz, 10.7, 14.2 Hz), 1.71 (s, 3H, Me), 1.24 (s, 3H, Me), 0.98 (s, 3H, Me), 0.90–0.96 (m, 9H, 3 Me), 0.55–0.60 (m, 6H, 3 CH<sub>2</sub>);  $^{13}\text{C}$  NMR (CDCl<sub>3</sub>, 100 MHz)  $\delta$  201.4, 170.4, 169.4, 165.8, 140.9, 134.3, 133.8, 130.1, 129.4, 128.8, 84.3, 81.3, 76.9, 76.6, 75.7, 75.4, 74.6, 72.5, 68.8, 59.0, 46.8, 43.3, 37.5, 30.1, 26.6, 22.8, 22.1, 21.3, 15.2, 10.4, 7.2, 5.7. Anal. Calcd C<sub>37</sub>H<sub>51</sub>N<sub>3</sub>O<sub>11</sub>Si: C, 59.90; H, 6.93; N, 5.66. Found: C, 60.11; H, 6.89; N, 5.70. Compound 13 $\beta$ -**38**: MS (*m/z*) ESI: 743 (M+H)<sup>+</sup>;  $^1\text{H}$  NMR (CDCl<sub>3</sub>, 400 MHz)  $\delta$  8.01–8.17 (m, 2H, arom), 7.52–7.58 (m, 1H, arom), 7.42–7.48 (m, 2H, arom), 6.51 (s, 1H, H-10), 5.88 (d, 1H, H-2,  $J=6.8$  Hz), 4.95 (dd, 1H, H-5,  $J=2.2, 9.6$  Hz), 4.70 (m, 1H, H-13), 4.48 (dd, 1H, H-7,  $J=7.1, 9.9$  Hz), 4.33 (d, 1H, H-20,  $J=8.4$  Hz), 4.25 (d, 1H, H-20,  $J=8.4$  Hz), 3.90 (d, 1H, H-14,  $J=7.4$  Hz), 3.78 (d, 1H, H-3,  $J=6.8$  Hz), 2.52 (ddd, 1H, H $\alpha$ -6,  $J=9.6, 7.1, 14.1$  Hz), 2.30 (s, 3H, Me), 2.22 (s, 3H, Me), 2.12 (s, 3H, Me), 1.92 (ddd, 1H, H $\beta$ -6,  $J=2.2, 9.9, 14.1$  Hz), 1.72 (s, 3H, Me), 1.30 (s, 3H, Me), 1.26 (s, 3H, Me), 0.88–0.92 (m, 9H, 3 Me), 0.55–0.60 (m, 6H, 3 CH<sub>2</sub>);  $^{13}\text{C}$  NMR (CDCl<sub>3</sub>, 100 MHz)  $\delta$  200.8, 170.0, 169.3, 165.6, 138.9, 138.3, 135.8, 131.5, 129.4, 128.8, 84.3, 81.0, 76.9, 76.6, 76.3, 75.1, 74.3, 71.2, 69.4, 59.4, 54.5, 47.2, 40.5, 30.5, 30.0, 22.2, 21.6, 21.2, 20.2, 10.2, 7.2, 5.7. Anal. Calcd C<sub>37</sub>H<sub>51</sub>N<sub>3</sub>O<sub>11</sub>Si: C, 59.90; H, 6.93; N, 5.66. Found: C, 60.21; H, 6.99; N, 5.60.

**4.1.20. 7-TES-13-[*N*-BOC-*N,O*-(2,4-dimethoxybenzylidene)- $\beta$ -isobutylisoserinoyl]-14 $\beta$ -azido-baccatin III (39).** A solution of 0.45 g (1.12 mmol) of **35** in 5.0 mL of toluene, cooled to  $0^{\circ}\text{C}$ , was added under nitrogen stream and stirring, with 0.50 g (0.67 mmol) of  $\alpha$ -**37**, 0.23 g (1.12 mmol) of DCC, 0.90 g (0.08 mmol) of DMAP, and 0.02 g (0.12 mmol) of *p*-toluenesulfonic acid (PTSA). After 1 h at  $70^{\circ}\text{C}$  the reaction mixture was cooled and filtered. The solid was extracted with CH<sub>2</sub>Cl<sub>2</sub>, and the organic phase was evaporated under reduced pressure. Chromatography of the crude mixture (SiO<sub>2</sub>, *n*-hexane/EtOAc, 2.2:1.0) afforded 0.63 g (0.54 mmol, 80%) of **39** as a white solid. IR (KBr, cm<sup>-1</sup>): 3491, 2957, 2111, 1731, 1614, 1508, 1368; [ $\alpha$ ]<sub>D</sub><sup>20</sup> +1.8 (c 0.7, CH<sub>2</sub>Cl<sub>2</sub>); MS (*m/z*) ESI: 1134 (M+H)<sup>+</sup>;  $^1\text{H}$  NMR (CDCl<sub>3</sub>, 400 MHz)  $\delta$  8.07–8.1 (m, 2H, arom), 7.58–7.62 (m, 1H, arom), 7.42–7.50 (m, 1H, arom), 7.22–7.28 (m,

1H, arom), 6.40–6.52 (m, 4H, 2H arom, H-10, N-CH-O), 6.25 (d, 1H, H-13,  $J=8.8$  Hz), 5.88 (d, 1H, H-2,  $J=7.6$  Hz), 4.94 (dd, 1H, H-5,  $J=1.5, 9.7$  Hz), 4.45–4.62 (m, 3H, H-7, H'-3, H'-2), 4.32 (d, 1H, H-20,  $J=8.0$  Hz), 4.24 (d, 1H, H-20,  $J=8.0$  Hz), 4.04 (d, 1H, H-14,  $J=8.8$  Hz), 3.87 (s, 3H, OMe), 3.83 (s, 3H, OMe), 3.83 (d, 1H, H-3,  $J=7.6$  Hz), 2.52 (ddd, 1H, H $\alpha$ -6,  $J=6.8, 9.6, 14.0$  Hz), 2.33 (s, 3H, Me), 2.19 (s, 3H, Me), 2.11 (s, 3H, Me), 1.91 (ddd, 1H, H $\beta$ -6,  $J=1.5, 11.2, 14.0$  Hz), 1.72–1.82 (m, 2H, H'-4, H'-5), 1.71 (s, 3H, Me), 1.54–1.64 (m, 1H, H'-4), 1.27 (s, 3H, Me), 1.22–1.40 (s, 9H, 3 Me), 1.16 (s, 3H, Me), 1.06 (d, 6H, 2 Me,  $J=6.0$  Hz), 0.90–0.98 (m, 9H, 3 Me), 0.58–0.4 (m, 6H, 3 CH<sub>2</sub>); <sup>13</sup>C NMR (CDCl<sub>3</sub>, 100 MHz)  $\delta$  201.2, 170.7, 170.1, 169.4, 165.9, 161.8, 159.3, 153.5, 137.1, 135.8, 134.0, 130.2, 130.1, 129.4, 128.9, 104.4, 101.5, 91.8, 86.5, 84.3, 81.2, 80.5, 76.6, 76.4, 74.8, 74.7, 72.3, 65.5, 58.7, 58.1, 55.6, 55.5, 46.4, 43.8, 43.5, 37.3, 28.4, 28.3, 26.6, 25.8, 23.2, 22.9, 22.6, 22.2, 21.0, 14.4, 10.3, 6.9, 5.5. Anal. Calcd C<sub>58</sub>H<sub>80</sub>N<sub>4</sub>O<sub>17</sub>Si: C, 61.47; H, 7.11; N, 4.94. Found: C, 61.60; H, 7.17; N, 5.05.

**4.1.21. 7-TES-13-[N-BOC-N,O-(2,4-dimethoxy-benzylidene)- $\beta$ -isobutylisoserinoyl]-14 $\beta$ -amino-baccatin III (40).** A solution of 0.25 g (0.23 mmol) of **39** in 9.0 mL of MeOH was reduced under balloon pressure of H<sub>2</sub> in the presence of 10% Pd/C (0.05 g). After 18 h at room temperature, the reaction mixture was filtered through celite bed, and the solid was washed with 25.0 mL of EtOAc. The organic phase was heated to 45 °C for 20 min and subsequently evaporated under reduced pressure. Chromatography of the residue (SiO<sub>2</sub>, *n*-hexane/EtOAc/CH<sub>2</sub>Cl<sub>2</sub>, 0.7:0.3:1.0) yielded 0.22 g (0.20 mmol, 90%) of **40** as a white solid. IR (KBr, cm<sup>-1</sup>): 3449, 2957, 1726, 1617, 1368, 1237, 1105; [ $\alpha$ ]<sub>D</sub><sup>20</sup> -39.6 (c 0.5, CH<sub>2</sub>Cl<sub>2</sub>); MS (*m/z*) ESI: 1108 (M+H)<sup>+</sup>; <sup>1</sup>H NMR (CDCl<sub>3</sub>, 400 MHz)  $\delta$  8.00–8.02 (m, 2H, arom), 7.54–7.60 (m, 1H, arom), 7.42–7.45 (m, 2H, arom), 7.22–7.28 (m, 1H, arom), 6.45–6.59 (m, 4H, 2H arom, H-10, N-CH-O), 6.06 (m, 1H, H-13), 5.85 (d, 1H, H-2,  $J=7.2$  Hz), 4.93 (d, 1H, H-5,  $J=2.0, 10.5$  Hz), 4.46–4.60 (m, 3H, H-7, H'-3, H'-2), 4.20–4.28 (m, 2H, H-20), 3.88 (s, 3H, OMe), 3.80–3.84 (m, 4H, OMe, H-3), 3.35 (d, 1H, H-14,  $J=8.8$  Hz), 2.51 (ddd, 1H, H $\alpha$ -6,  $J=6.4, 10.4, 14.4$  Hz), 2.30 (s, 3H, Me), 2.18 (s, 3H, Me), 2.12 (s, 3H, Me), 1.91 (ddd, 1H, H $\beta$ -6,  $J=2.0, 10.5, 13.5$  Hz), 1.74–1.84 (m, 1H, H'-5), 1.72 (s, 3H, Me), 1.54–1.64 (m, 2H, H'-4), 1.20–1.40 (s, 9H, 3 Me), 1.11 (s, 3H, Me), 1.09 (d, 3H, Me,  $J=6.0$  Hz), 1.06 (d, 3H, Me,  $J=6.0$  Hz), 0.90–0.97 (m, 9H, 3 Me), 0.54–0.62 (m, 6H, 3 CH<sub>2</sub>); <sup>13</sup>C NMR (CDCl<sub>3</sub>, 100 MHz)  $\delta$  201.4, 172.4, 169.9, 169.5, 165.6, 161.8, 159.3, 153.5, 136.9, 136.0, 133.5, 130.1, 129.9, 128.9, 128.8, 128.5, 104.4, 98.6, 84.2, 81.3, 81.1, 80.1, 78.8, 76.4, 75.2, 75.1, 75.0, 72.3, 58.8, 58.5, 55.6, 54.1, 46.1, 43.8, 43.4, 37.4, 28.3, 28.1, 26.5, 25.7, 23.4, 23.1, 22.6, 22.3, 21.0, 14.7, 10.4, 7.0, 5.5. Anal. Calcd C<sub>58</sub>H<sub>82</sub>N<sub>2</sub>O<sub>17</sub>Si: C, 62.91; H, 7.46; N, 2.53. Found: C, 63.03; H, 7.35; N, 2.62.

**4.1.22. 7-TES-13-[N-BOC-N,O-(2,4-dimethoxybenzylidene)- $\beta$ -isobutylisoserinoyl]-14 $\beta$ -amino-baccatin III 14,1-thiocarbamate (41).** A solution of 0.17 g (0.15 mmol) of **40** in 7.0 mL of CH<sub>3</sub>CN was added, at 20 °C, with 0.14 g (0.61 mmol) of di-2-pyridyl-thionocarbonate. After 2 h, the reaction mixture was quenched by addition of 4.0 mL of water and extracted with CH<sub>2</sub>Cl<sub>2</sub>.

The organic phase was dried, filtered, and evaporated under reduced pressure. Chromatography of the residue (SiO<sub>2</sub>, *n*-hexane/EtOAc/CH<sub>2</sub>Cl<sub>2</sub>, 1.4:1.0:2.0) afforded 0.13 g (0.11 mmol, 73%) of **41** as a white solid. IR (KBr, cm<sup>-1</sup>): 3446, 2958, 1732, 1694, 1595, 1278, 1167; [ $\alpha$ ]<sub>D</sub><sup>20</sup> -21.3 (c 0.9, CH<sub>2</sub>Cl<sub>2</sub>); MS (*m/z*) ESI: 1150 (M+H)<sup>+</sup>; <sup>1</sup>H NMR (CDCl<sub>3</sub>, 400 MHz, 55 °C)  $\delta$  8.54–8.68 (b, 1H, HNCS), 7.96–7.98 (m, 2H, arom), 7.54–7.57 (m, 1H, arom), 7.37–7.41 (m, 2H, arom), 7.19 (m, 1H, arom), 6.42–6.54 (m, 4H, 2H arom, H-10, N-CH-O), 6.03–6.13 (m, 2H, H-13, H-2), 4.90 (dd, 1H, H-5,  $J=1.5, 9.7$  Hz), 4.53–4.62 (m, 2H, H'-2, H'-3), 4.49 (dd, 1H, H-7,  $J=6.6, 10.5$  Hz), 4.23–4.29 (m, 3H, H-14, H-20, H-20), 3.87 (s, 3H, Me), 3.82 (s, 3H, Me), 3.76 (d, 1H, H-3,  $J=7.4$  Hz), 2.51 (ddd, 1H, H $\alpha$ -6,  $J=6.6, 9.7, 14.3$  Hz), 2.23 (s, 3H, Me), 2.19 (s, 3H, Me), 2.13 (s, 3H, Me), 1.86–1.94 (ddd, 1H, H $\beta$ -6,  $J=1.5, 10.5, 14.3$  Hz), 1.75–1.88 (m, 2H, H'-4, H'-5), 1.73 (s, 3H, Me), 1.50–1.60 (m, 1H, H'-4), 1.36 (s, 3H, Me), 1.20–1.40 (s, 9H, 3 Me), 1.27 (s, 3H, Me), 1.09 (d, 3H, Me,  $J=6.0$  Hz), 1.05 (d, 3H, Me,  $J=6.0$  Hz), 0.88–0.98 (m, 9H, 3 Me), 0.55–0.60 (m, 6H, 3 CH<sub>2</sub>); <sup>13</sup>C NMR (CDCl<sub>3</sub>, 100 MHz)  $\delta$  200.4, 187.5, 171.5, 169.9, 169.2, 164.8, 161.6, 159.0, 137.9, 134.7, 133.8, 129.9, 129.1, 128.8, 127.9, 118.9, 104.3, 98.6, 95.8, 87.0, 84.2, 81.6, 80.7, 80.3, 76.3, 76.0, 74.6, 72.1, 70.6, 62.8, 58.8, 55.7, 55.6, 46.4, 43.8, 42.7, 37.5, 30.8, 28.5, 26.3, 25.8, 23.3, 22.8, 22.6, 22.3, 21.2, 15.0, 10.7, 7.2, 5.7. Anal. Calcd C<sub>59</sub>H<sub>80</sub>N<sub>2</sub>O<sub>17</sub>SSi: C, 61.65; H, 7.02; N, 2.44. Found: C, 61.52; H, 7.10; N, 2.53.

**4.1.23. 7-TES-13-[N-BOC-N,O-(2,4-dimethoxybenzylidene)- $\beta$ -isobutylisoserinoyl]-14 $\beta$ -amino-baccatin III 14,1-carbamate (36).** *Procedure A.* A solution of 0.12 g (0.30 mmol) of the acid **35** in 6.0 mL of toluene, cooled at 0 °C, was added with 0.10 g (0.14 mmol) of 13 $\alpha$ -**33**, 0.06 g (0.30 mmol) of DCC, 0.02 g (0.15 mmol) of DMAP, and 0.005 g (0.03 mmol) of PTSA, under stirring and nitrogen stream. After 2 h at 70 °C, an additional amount of 0.04 g (0.11 mmol) of **36** and 0.02 g (0.11 mmol) of DCC were added. After 3 h, the reaction was cooled and filtered. The solid was washed with CH<sub>2</sub>Cl<sub>2</sub>, and the organic phase was concentrated under reduced pressure. Chromatography of the reaction mixture (SiO<sub>2</sub>, *n*-hexane/EtOAc/CH<sub>2</sub>Cl<sub>2</sub>, 1.0:0.6:0.6) yielded 0.13 g (0.11 mmol, 80%) of **36** as a white solid. *Procedure B.* A 1.93 M solution of phosgene in toluene (0.50 mL, 0.81 mmol) and 0.1 mL (1.29 mmol) of pyridine were added to a solution of 0.36 g (0.32 mmol) of **40** in 9.0 mL of CH<sub>2</sub>Cl<sub>2</sub> at 0 °C under stirring. After 12 h at room temperature the reaction mixture was quenched by addition of 10.0 mL of water and extracted with 10.0 mL of CH<sub>2</sub>Cl<sub>2</sub>. The organic phase was washed with brine, dried, filtered, and evaporated under reduced pressure. Chromatography (SiO<sub>2</sub>, *n*-hexane/EtOAc/CH<sub>2</sub>Cl<sub>2</sub>, 0.7:0.3:1.0) gave 0.27 g (0.24 mmol, 74%) of **36** as a white solid. IR (KBr, cm<sup>-1</sup>): 3435, 2956, 1735, 1454, 1369, 1235; [ $\alpha$ ]<sub>D</sub><sup>20</sup> -38.7 (c 0.7, CH<sub>2</sub>Cl<sub>2</sub>); MS (*m/z*) ESI: 1134 (M+H)<sup>+</sup>; <sup>1</sup>H NMR (CDCl<sub>3</sub>, 400 MHz)  $\delta$  7.98–7.99 (m, 2H, arom), 7.56–7.60 (m, 1H, arom), 7.40–7.44 (m, 2H, arom), 7.18–7.22 (m, 1H, arom), 6.40–6.50 (m, 5H, 2H arom, H-10, N-CH-O, HNC=O), 6.00–6.08 (m, 2H, H-2, H-13), 4.90 (dd, 1H, H-5,  $J=2.0, 10.4$  Hz), 4.53–4.62 (m, 2H, H'-2, H'-3), 4.49 (dd, 1H, H-7,  $J=6.6, 10.5$  Hz), 4.26 (d, 1H, H-20,  $J=7.6$  Hz), 4.22 (d, 1H, H-20,  $J=7.6$  Hz), 4.08–4.14 (m, 1H, H-14), 3.88 (s, 3H, OMe), 3.87 (s, 3H, OMe), 3.76 (d, 1H,

H-3,  $J=7.2$  Hz), 2.52 (ddd, 1H, H $\alpha$ -6,  $J=6.6$ , 10.4, 14.4 Hz), 2.26 (s, 3H, Me), 2.19 (s, 3H, Me), 2.10–2.18 (s, 3H, Me), 1.91 (ddd, 1H, H $\beta$ -6,  $J=2.0$ , 10.5, 14.4 Hz), 1.78–1.83 (m, 2H, H'-4, H'-5), 1.75 (s, 3H, Me), 1.60–1.64 (m, 1H, H'-4), 1.34 (s, 3H, Me), 1.22–1.38 (m, 9H, 3 Me), 1.26 (s, 3H, Me), 1.09 (d, 3H, Me,  $J=6.0$  Hz), 1.06 (d, 3H, Me,  $J=6.0$  Hz), 0.90–0.96 (m, 9H, 3 Me), 0.55–0.62 (m, 6H, 3 CH<sub>2</sub>); <sup>13</sup>C NMR (CDCl<sub>3</sub>, 100 MHz)  $\delta$  202.5, 173.5, 171.2, 169.6, 164.9, 156.4, 140.1, 134.1, 134.0, 130.0, 128.9, 128.7, 87.5, 84.4, 81.7, 81.2, 78.1, 76.4, 75.3, 73.0, 72.1, 71.2, 58.8, 57.8, 51.8, 44.9, 42.5, 41.8, 35.8, 30.1, 28.7, 26.3, 25.0, 23.8, 23.4, 21.8, 21.2, 15.4, 10.2. Anal. Calcd C<sub>59</sub>H<sub>80</sub>N<sub>2</sub>O<sub>18</sub>Si: C, 62.53; H, 7.11; N, 2.47. Found: C, 62.70; H, 7.15; N, 2.38.

**4.1.24. 7-TES-13-[N-BOC-N,O-(2,4-dimethoxybenzylidene)- $\beta$ -isobutylisoserinoyl]-14 $\beta$ -*t*-butoxy-carbamoyl-baccatin III 14,1-carbamate (42).** A solution of 0.11 g (0.10 mmol) of **40** in 3.0 mL of CH<sub>2</sub>Cl<sub>2</sub> was added with 0.04 g (0.20 mmol) of BOC<sub>2</sub>O, 0.03 mL (0.21 mmol) of Et<sub>3</sub>N and 0.01 g (0.05 mmol) of DMAP, at 20 °C. After 3 h the reaction was quenched by addition of 4.0 mL of a NH<sub>4</sub>Cl aqueous saturated solution and extracted with 6.0 mL of CH<sub>2</sub>Cl<sub>2</sub>. The organic phase was dried, filtered, and evaporated under reduced pressure. Chromatography (SiO<sub>2</sub>, *n*-hexane/EtOAc/CH<sub>2</sub>Cl<sub>2</sub>, 8.0:3.0:5.0) gave 0.09 g (0.06 mmol, 69%) of **42** as a white solid. IR (KBr, cm<sup>-1</sup>): 3450, 2961, 1803, 1733, 1370, 1239, 1089; MS ( $m/z$ ) ESI: 1234 (M+H)<sup>+</sup>; <sup>1</sup>H NMR (CDCl<sub>3</sub>, 400 MHz)  $\delta$  7.92–7.98 (m, 2H, arom), 7.51–7.58 (m, 1H, arom), 7.32–7.42 (m, 2H, arom), 6.47–6.51 (m, 3H, 2H arom, N-CH-O), 6.40–6.44 (m, 1H, H-13), 6.36 (s, 1H, H-10), 6.01 (d, 1H, H-2,  $J=7.2$  Hz), 4.93 (dd, 1H, H-5  $J=2.2$ , 10.0 Hz), 4.76 (d, 1H,  $J=7.2$  Hz, HNBOC), 4.56 (dd, 1H, H-7,  $J=6.4$ , 10.2 Hz), 4.48–4.60 (m, 2H, H'-2, H'-3), 4.24 (d, 1H, H-20), 4.18 (d, 1H, H-20,  $J=8.0$  Hz), 3.88 (s, 3H, OMe), 3.85 (d, 1H, H-3,  $J=7.2$  Hz), 3.82 (s, 3H, OMe), 2.52 (ddd, 1H, H $\alpha$ -6,  $J=6.4$ , 10.0, 14.8 Hz), 2.46 (s, 3H, Me), 2.23 (s, 3H, Me), 2.19 (s, 3H, Me), 1.90 (ddd, 1H, H $\beta$ -6,  $J=2.2$ , 10.2, 14.5 Hz), 1.72 (s, 3H, Me), 1.64–1.70 (m, 1H, H'-5), 1.38–1.50 (m, 2H, H'-4), 1.37 (s, 9H), 1.35 (s, 3H, Me), 1.28 (s, 3H, Me), 1.12–1.16 (m, 6H, 2 Me), 0.92–0.96 (m, 9H, 3 Me), 0.56–0.63 (m, 6H, 3 CH<sub>2</sub>); <sup>13</sup>C NMR (CDCl<sub>3</sub>, 100 MHz) relevant resonances at  $\delta$  200.7, 171.0, 170.5 (b), 169.2 (b), 164.6, 161.6, 159.2, 151.2, 150.4, 148.0 (b), 139.5, 134.2, 133.9, 129.9, 129.0, 128.5, 127.4 (b), 117.8 (b), 104.5, 86.5, 85.5 (b), 84.8, (b), 84.4, 80.7 (b), 80.2, 76.2, 74.7, 74.1, 72.1, 71.3, 59.8, 58.7, 57.8 (b), 55.7, 55.5, 46.3, 43.7, 42.1, 37.4, 30.1 (b), 28.6 (b), 28.1, 26.7, 26.1 (CH), 23.7, 23.0, 22.4, 22.2, 21.2, 15.5, 10.7, 7.2, 5.7. Anal. Calcd C<sub>64</sub>H<sub>88</sub>N<sub>2</sub>O<sub>20</sub>Si: C, 62.32; H, 7.19; N, 2.27. Found: C, 62.41; H, 7.16; N, 2.34.

**4.1.25. 13-(N-BOC- $\beta$ -isobutylisoserinoyl)-14 $\beta$ -azido-baccatin III (44).** Hydrofluoric acid-pyridine (1.6 mL, 0.1 mL/10 mg of substrate) was added, at 0 °C, to a solution of 0.16 g (0.14 mmol) of **39** in 4.0 mL of acetonitrile and 4 mL of pyridine. After half an hour, the temperature was raised to 25 °C. After 3 h the reaction was quenched by addition of 8.0 mL of a NH<sub>4</sub>Cl saturated solution and extracted with EtOAc. The organic phase was washed with an aqueous saturated solution of CuSO<sub>4</sub>, dried, filtered, and evaporated under reduced pressure. The residue was

dissolved in 3.0 mL of CH<sub>2</sub>Cl<sub>2</sub> and added at 0 °C to 1.4 mL of a 0.1 M solution of acetyl chloride in MeOH. After 3 h the reaction was quenched by addition of 6.0 mL of a NH<sub>4</sub>Cl aqueous saturated solution. The organic phase was dried, filtered, and evaporated under reduced pressure. Chromatography (SiO<sub>2</sub>, *n*-hexane/EtOAc, 1.0:1.2) yielded 0.08 g (0.10 mmol, 70%) of **44** as a white solid. IR (KBr, cm<sup>-1</sup>): 3492, 2960, 2111, 1730, 1614, 1369, 1237, 1070; [ $\alpha$ ]<sub>D</sub><sup>20</sup> -27.7 (c 0.5, CH<sub>2</sub>Cl<sub>2</sub>); MS ( $m/z$ ) ESI: 872 (M+H)<sup>+</sup>; <sup>1</sup>H NMR (CDCl<sub>3</sub>, 400 MHz)  $\delta$  8.07–8.1 (m, 2H, arom), 7.58–7.62 (m, 1H, arom), 7.44–7.50 (m, 2H, arom), 6.28 (s, 1H, H-10), 6.07 (d, 1H, H-13,  $J=8.8$  Hz), 5.88 (d, 1H, H-2,  $J=7.1$  Hz), 4.98 (m, 1H, H-5,  $J=2.3$ , 9.6 Hz), 4.72 (d, 1H, HNBOC,  $J=9.6$  Hz), 4.39 (dd, 1H, H-7,  $J=6.6$ , 10.7 Hz), 4.35 (d, 1H, H-20,  $J=8.8$  Hz), 4.26 (m, 2H, H-20, H'-2), 4.08–4.12 (m, 1H, H'-3), 4.04 (d, 1H, H-14,  $J=8.8$  Hz), 3.76 (d, 1H, H-3,  $J=7.1$  Hz), 2.57 (ddd, 1H, H $\alpha$ -6,  $J=6.6$ , 9.6, 14.9 Hz), 2.43 (s, 3H, Me), 2.24 (s, 3H, Me), 1.91 (ddd, 1H, H $\beta$ -6,  $J=2.3$ , 10.7, 14.8 Hz), 1.88 (s, 3H, Me), 1.71 (s, 3H, Me), 1.62–1.76 (m, 3H, H-5', 2H-4'), 1.41 (s, 9H, 3 Me), 1.21 (s, 3H, Me), 1.20 (s, 3H, Me), 0.99 (d, 3H, Me,  $J=6.0$  Hz), 0.97 (d, 3H, Me,  $J=6.0$  Hz); <sup>13</sup>C NMR (CDCl<sub>3</sub>, 100 MHz)  $\delta$  202.9, 173.4, 171.1, 170.0, 165.7, 156.2, 139.1, 134.9, 133.9, 130.1, 129.1, 128.9, 84.5, 81.6, 80.5, 77.6, 77.2, 76.5, 75.5, 74.8, 74.1, 72.3, 65.5, 59.0, 52.0, 45.3, 43.5, 40.8, 35.9, 28.6, 27.1, 25.1, 23.6, 22.7, 22.3, 21.3, 15.3, 10.0. Anal. Calcd C<sub>43</sub>H<sub>58</sub>N<sub>4</sub>O<sub>15</sub>: C, 59.30; H, 6.71; N, 6.43. Found: C, 59.36; H, 6.62, N, 6.34.

**4.1.26. 13-(N-BOC- $\beta$ -isobutylisoserinoyl)-14 $\beta$ -amino-baccatin III (45).** Hydrofluoric acid-pyridine (2.2 mL, 0.1 mL/10 mg of substrate) was added, at 0 °C, to a solution of 0.22 g (0.18 mmol) of **40** in 5.4 mL of acetonitrile and 5.4 mL of pyridine. After 30 min the temperature was raised to 25 °C. After 3 h, the reaction was quenched by addition of 12.0 mL of a NH<sub>4</sub>Cl aqueous saturated solution and extracted with 16.0 mL of EtOAc. The organic phase was washed three times with a CuSO<sub>4</sub> aqueous saturated solution, dried, filtered, and evaporated under reduced pressure. The residue was dissolved in 7.0 mL of CH<sub>2</sub>Cl<sub>2</sub>, and added, at 0 °C, to 2.3 mL of a 0.1 M acetyl chloride solution in MeOH. After 3 h, the reaction was quenched by addition of 10.0 mL of a NH<sub>4</sub>Cl aqueous saturated solution and extracted with 16.0 mL of EtOAc. The organic phases were dried, filtered, and evaporated under reduced pressure. Chromatography (SiO<sub>2</sub>, *n*-hexane/EtOAc, 1.0:1.2) yielded 0.10 g (0.12 mmol, 70%) of **45** as a white solid. IR (KBr, cm<sup>-1</sup>): 3428, 2957, 1729, 1615, 1360, 1237; [ $\alpha$ ]<sub>D</sub><sup>20</sup> -39.4 (c 0.8, CH<sub>2</sub>Cl<sub>2</sub>); MS ( $m/z$ ) ESI: 846 (M+H)<sup>+</sup>; <sup>1</sup>H NMR (CDCl<sub>3</sub>, 400 MHz)  $\delta$  8.0–8.06 (d, 2H, arom); 7.52–7.61 (m, 1H, arom), 7.42–7.46 (m, 2H, arom), 6.27 (s, 1H, H-10), 5.90 (dd, 1H, H-13,  $J=1.2$ , 9.2 Hz), 5.81 (d, 1H, H-2,  $J=7.6$  Hz), 4.92–4.96 (dd, 1H, H-5,  $J=2.5$ , 9.6 Hz), 4.70 (d, 1H, HNBOC,  $J=9.6$  Hz), 4.39–4.43 (m, 1H, H-7), 4.18–4.33 (m, 4H, H-2', H-3', H-20, H-20), 3.74 (d, 1H, H-3,  $J=7.2$  Hz), 3.35 (d, 1H, H-14,  $J=9.2$  Hz), 2.55 (m, 1H, H $\alpha$ -6,  $J=6.4$ , 9.6, 14.8 Hz), 2.39 (s, 3H, Me), 2.24 (s, 3H, Me), 1.84–1.94 (m, 1H, H $\beta$ -6,  $J=2.5$ , 11.2, 14.8 Hz), 1.88 (m, 3H, Me), 1.62–1.80 (m, 3H, 2H'-4, H-5'), 1.71 (s, 3H, Me), 1.32 (s, 9H, 3 Me), 1.19 (s, 3H, Me), 1.14 (s, 3H, Me), 1.01 (d, 3H, Me,  $J=6.0$  Hz), 0.98 (d, 3H, Me,  $J=6.0$  Hz); <sup>13</sup>C NMR (CDCl<sub>3</sub>, 100 MHz)  $\delta$  203.3, 174.4, 171.4, 169.8, 165.6, 156.1, 138.8, 135.0, 133.4, 130.0, 129.8, 128.8, 84.5,

81.5, 80.6, 76.6, 75.7, 75.3, 75.1, 72.9, 72.3, 58.7, 53.5, 51.4, 45.0, 43.3, 42.2, 35.8, 28.6, 26.9, 25.1, 24.4, 23.7, 23.0, 22.3, 21.3, 15.3, 10.1. Anal. Calcd C<sub>43</sub>H<sub>60</sub>N<sub>2</sub>O<sub>15</sub>: C, 61.12; H, 7.16; N, 3.32. Found: C, 61.33; H, 7.09; N, 3.24.

**4.1.27. 13-(*N*-BOC- $\beta$ -isobutylisoserinoyl)-14 $\beta$ -amino-baccatin III 14,1-thiocarbamate (46).** Hydrofluoric acid-pyridine (1.7 mL, 0.1 mL/10 mg of substrate) was added, at 0 °C, to a solution of 0.17 g (0.15 mmol) of **41** in 4.0 mL of acetonitrile and 4.0 mL of pyridine. After 30 min the temperature was raised to 25 °C. After 3 h, the reaction was quenched by addition of 12.0 mL of a NH<sub>4</sub>Cl aqueous saturated solution and extracted with 16.0 mL of EtOAc. The organic phase was washed with aqueous saturated CuSO<sub>4</sub>, dried, filtered, and evaporated under reduced pressure. The residue was dissolved in 6.0 mL of CH<sub>2</sub>Cl<sub>2</sub> and chilled at 0 °C. A 0.1 M solution of acetyl chloride in MeOH (1.2 mL) was added. The reaction was quenched after 3 h by addition of 12.0 mL of saturated aqueous NH<sub>4</sub>Cl and extracted with EtOAc. The organic phase was dried, filtered, and evaporated under reduced pressure. Chromatography of the residue (SiO<sub>2</sub>, EtOAc/*n*-hexane, 1.4:1) gave 0.09 g (0.01 mmol, 67%) of **46** as a white solid. IR (KBr, cm<sup>-1</sup>): 3343, 2960, 1733, 1686, 1595, 1239, 1088, 733; [ $\alpha$ ]<sub>D</sub><sup>20</sup> -4.7 (*c* 0.4, CH<sub>2</sub>Cl<sub>2</sub>); MS (*m/z*) ESI: 888 (M+H)<sup>+</sup>; <sup>1</sup>H NMR (CDCl<sub>3</sub>, 400 MHz)  $\delta$  9.34 (s, 1H, HNCS), 7.99–8.01 (m, 2H, arom), 7.49–7.52 (m, 1H, arom), 7.40–7.45 (m, 2H, arom), 6.26 (s, 1H, H-10), 6.09–6.14 (m, 2H, H-2, H-13), 4.94 (dd, 1H, H-5, *J*=2.5, 9.7 Hz), 4.78 (d, 1H, HNBOC, *J*=9.2 Hz), 4.34–4.40 (m, 2H, H-7, H-14), 4.28–4.32 (m, 2H, H-20, H'-20), 4.10–4.18 (m, 2H, H-3', H-2'), 3.72 (d, 1H, H-3, *J*=7.5 Hz), 2.48 (m, 1H, H $\alpha$ -6, *J*=6.6, 9.7, 14.5 Hz), 2.31 (s, 3H, Me), 2.24 (s, 3H, Me), 1.90 (m, 3H, H $\beta$ -6, *J*=2.5, 10.8, 14.5 Hz), 1.86 (s, 3H, Me), 1.70–1.85 (m, 3H, 2H'-4, H'-5), 1.73 (s, 3H, Me), 1.41 (s, 9H, 3 Me), 1.29 (s, 6H, 2 Me), 1.02 (d, 3H, Me, *J*=6.0 Hz), 0.98 (d, 3H, Me, *J*=6.0 Hz); <sup>13</sup>C NMR (CDCl<sub>3</sub>, 100 MHz)  $\delta$  202.3, 173.5, 171.0, 169.5, 164.8, 156.2, 139.9, 134.1, 133.9, 130.0, 129.8, 128.8, 94.8, 84.4, 82.1, 81.6, 81.2, 76.7, 76.4, 75.3, 72.8, 72.0, 70.7, 62.0, 58.9, 52.0, 45.3, 42.7, 41.6, 35.9, 28.7, 26.2, 25.0, 23.7, 23.1, 21.9, 21.2, 15.3, 10.2. Anal. Calcd C<sub>44</sub>H<sub>58</sub>N<sub>2</sub>O<sub>15</sub>S: C, 59.58; H, 6.59; N, 3.16. Found: C, 59.40; H, 6.64; N, 3.22.

**4.1.28. 13-*N*-BOC- $\beta$ -isobutylisoserinoyl-14 $\beta$ -amino-baccatin III 14,1-carbamate (43).** Hydrofluoric acid-pyridine (1.1 mL, 0.1 mL/10 mg of substrate) was added, at 0 °C, to a solution of 0.11 g (0.10 mmol) of **36** in 2.7 mL of acetonitrile and 2.7 mL of pyridine. After 30 min the temperature was raised to 25 °C. After 3 h, the reaction was quenched by addition of 6.0 mL of a NH<sub>4</sub>Cl aqueous saturated solution and extracted with 16.0 mL of EtOAc. The organic phase was washed three times with a CuSO<sub>4</sub> aqueous saturated solution, dried, filtered, and evaporated under reduced pressure. The residue was dissolved in 3.5 mL of CH<sub>2</sub>Cl<sub>2</sub>, and then, at 0 °C, added with 1.15 mL of a 0.1 M acetyl chloride solution in MeOH. After 3 h, the reaction was quenched by addition of 5.0 mL of a NH<sub>4</sub>Cl aqueous saturated solution and extracted with 8.0 mL of EtOAc. The organic phase was dried, filtered, and evaporated under reduced pressure. Chromatography (SiO<sub>2</sub>, *n*-hexane/EtOAc/Et<sub>2</sub>O 1:0.7:0.3) afforded 0.06 g (0.06 mmol, 66%) of **43** as a white solid. IR (KBr, cm<sup>-1</sup>):

3420, 2089, 1742, 1636, 1370, 1093; [ $\alpha$ ]<sub>D</sub><sup>20</sup> -53.4 (*c* 0.7, CH<sub>2</sub>Cl<sub>2</sub>); MS (*m/z*) ESI: 872 (M+H)<sup>+</sup>; <sup>1</sup>H NMR (CDCl<sub>3</sub>, 400 MHz)  $\delta$  8.02–8.1 (m, 2H, arom), 7.54–7.58 (m, 1H, arom), 7.54 (d, 1H, HNCO, *J*=8.6 Hz), 7.42–7.45 (m, 2H, arom), 6.26 (s, 1H, H-10), 6.11 (dd, 1H, H-13, *J*=1.5, 6.8 Hz), 6.02 (d, 1H, H-2, *J*=7.2 Hz), 4.94 (dd, 1H, H-5, *J*=2.6, 9.8 Hz), 4.73 (d, 1H, HNBOC, *J*=9.6 Hz), 4.36–4.39 (m, 1H, H-7), 4.24–4.32 (m, 2H, H-20, H'-20), 4.15–4.22 (m, 3H, H-14, H-2', H-3'), 3.76 (d, 1H, H-3, *J*=7.2 Hz), 2.55 (ddd, 1H, H $\alpha$ -6, *J*=6.5, 9.8, 14.5 Hz), 2.33 (s, 3H, Me), 2.25 (s, 3H, Me), 1.86–1.96 (ddd, 1H, H $\beta$ -6, *J*=2.5, 11.0, 14.5 Hz), 1.86 (s, 3H, Me), 1.78–1.84 (m, 1H, H'-5), 1.73 (s, 3H, Me), 1.66–1.76 (m, 1H, H'-4), 1.37 (s, 9H, 3 Me), 1.31 (s, 3H, Me), 1.20–1.40 (m, 9H, 3 Me), 1.25 (s, 3H, Me), 1.25–1.30 (m, 1H, H'-4), 1.01 (d, 3H, 1 Me, *J*=6.5 Hz), 0.98 (d, 3H, 1 Me, *J*=6.5 Hz); <sup>13</sup>C NMR (CDCl<sub>3</sub>, 100 MHz)  $\delta$  202.5, 173.5, 171.2, 169.6, 164.9, 156.4, 140.1, 134.1, 134.0, 130.0, 128.9, 128.7, 87.5, 84.4, 81.7, 81.2, 78.1, 76.4, 75.3, 73.0, 72.1, 71.2, 58.8, 57.8, 51.8, 44.9, 42.5, 41.8, 35.8, 30.1, 28.7, 26.3, 25.0, 23.8, 23.4, 21.8, 21.2, 15.4, 10.2. Anal. Calcd C<sub>44</sub>H<sub>58</sub>N<sub>2</sub>O<sub>16</sub>: C, 60.68; H, 6.71; N, 3.22. Found: C, 60.52; H, 6.79; N, 3.16.

**4.1.29. 13-(*N*-BOC- $\beta$ -isobutylisoserinoyl)-14 $\beta$ -*t*-butoxycarbamoyl-baccatin III 14,1-carbamate (47).** Hydrofluoric acid-pyridine (1.6 mL, 0.1 mL/10 mg of substrate) was added, at 0 °C, to a solution of 0.16 g (0.14 mmol) of **42** in 4.0 mL of acetonitrile and 4.0 mL of pyridine. After 30 min the temperature was raised to 25 °C. After 3 h, the reaction was quenched by addition of 12.0 mL of a NH<sub>4</sub>Cl aqueous saturated solution and extracted with 12.0 mL of EtOAc. The organic phase was washed with a saturated aqueous solution of CuSO<sub>4</sub>, dried, filtered, and evaporated under reduced pressure. The residue was dissolved in 6.0 mL of CH<sub>2</sub>Cl<sub>2</sub>, then added with 1.6 mL of a 0.1 M solution of acetyl chloride in MeOH, at 0 °C. After 3 h the reaction was quenched by addition of 15.0 mL of saturated aqueous NH<sub>4</sub>Cl and extracted with 15.0 mL of EtOAc. The organic phase is dried, filtered, and evaporated under reduced pressure. Chromatography of the residue (SiO<sub>2</sub>, *n*-hexane/EtOAc, 1.0:1.2) yield 0.08 g (0.08 mmol, 57%) of **47** as a white solid. IR (KBr, cm<sup>-1</sup>): 3450, 2961, 1803, 1733, 1506, 1370, 1239, 1089, 732; [ $\alpha$ ]<sub>D</sub><sup>20</sup> -37.2 (*c* 0.8, CH<sub>2</sub>Cl<sub>2</sub>); MS (*m/z*) ESI: 972 (M+H)<sup>+</sup>; <sup>1</sup>H NMR (CDCl<sub>3</sub>, 400 MHz)  $\delta$  7.95–7.97 (m, 2H, arom), 7.54–7.58 (m, 1H, arom), 7.38–7.42 (m, 2H, arom), 6.26 (m, 2H, H-10, H-13), 6.01 (d, 1H, H-2, *J*=7.2 Hz), 4.96 (dd, 1H, H-5, *J*=2.4, 9.2 Hz), 4.89 (d, 1H, HNBOC, *J*=8.8 Hz), 4.74 (d, 1H, H-14, *J*=7.6 Hz), 4.42 (dd, 1H, H-7, *J*=6.4, 10.8 Hz), 4.22–4.28 (m, 3H, 2H-20, H-2'), 4.20–4.12 (m, 1H, H-3'), 3.82 (d, 1H, H-3, *J*=7.2 Hz), 2.57 (ddd, 1H, H $\alpha$ -6, *J*=6.4, 9.2, 14.5 Hz), 2.53 (s, 3H, Me), 2.25 (s, 3H, Me), 1.91 (s, 3H, Me), 1.86–1.94 (ddd, 1H, H $\beta$ -6, *J*=2.4, 10.8, 14.5 Hz), 1.72 (s, 3H, Me), 1.62–1.72 (m, 2H, H'-4, H'-5), 1.48–1.58 (m, 1H, H'-4), 1.43 (s, 9H, 3 Me), 1.38 (s, 9H, 3 Me), 1.31 (s, 3H, Me), 1.28 (s, 3H, Me), 0.97 (d, 3H, 1 Me, *J*=6.5 Hz), 0.98 (d, 3H, 1 Me, *J*=6.5 Hz); <sup>13</sup>C NMR (CDCl<sub>3</sub>, 100 MHz)  $\delta$  202.5, 171.2, 171.0, 169.5, 164.4, 155.9, 150.2, 141.4, 134.0, 133.3, 129.9, 129.0, 128.4, 85.4, 84.6, 80.7, 80.1, 76.3, 75.3, 74.2, 72.1, 71.2, 59.5, 58.9, 51.6, 45.2, 42.0, 40.6, 35.9, 33.4, 32.0, 30.0, 28.7, 28.1, 27.0, 25.3, 23.5, 23.3, 22.6, 21.2, 16.0, 10.2. Anal. Calcd C<sub>49</sub>H<sub>66</sub>N<sub>2</sub>O<sub>18</sub>: C, 60.61; H, 6.85; N, 2.88. Found: C, 60.44; H, 6.74; N, 2.93.

**Table 2.** Relevant  $^1\text{H}$  NMR resonances of 13-oxo *ortho* esters (**21**, **22**, and **27**), 13-silyl enol ethers (**3**, **28**, and **29**), and 13, 21-bis-silyl-enol *ortho* esters (**23–26**)

Resonances	<b>29</b>	<b>28</b>	<b>3</b>	<b>27</b>	<b>26</b>	<b>25</b>	<b>24</b>	<b>23</b>	<b>22</b>	<b>21</b>
H-2	5.77	5.75	5.76	4.35	3.97	4.50	4.02	4.48	3.90	4.39
H-14	4.82	4.73	4.73	2.37	5.36	4.46	5.42	4.46	3.07	2.53
H-14'	—	—	—	2.37	—	—	—	—	2.91	2.29
H-3	3.74	3.71	3.71	3.45	3.40	3.37	3.40	3.35	3.57	3.50
Me-19	1.70	1.67	1.69	1.79	1.62	1.79	1.63	1.78	1.65	1.78
Me-16	1.15	1.10	1.12	1.22	0.80	1.17	0.80	1.15	0.98	1.20

### Appendix A. Stereochemical assessments of *ortho* esters **21**, **22**, and **27**, of 13-enol derivatives **3**, **28**, and **29** and 13-enol *ortho* esters **23–26** based on $^1\text{H}$ and $^{13}\text{C}$ NMR spectroscopic evidences

(a):  $^1\text{H}$  NMR evidences. The structures of 13-oxo-*ortho* esters **21**, **22**, and **27** were supported by the presence of two relevant resonances for the hydrogen atoms at C-14 (H-14 and H'-14), and one resonance for the silyl substituent at C-21. The 13-silyl enol ethers **3**, **28**, and **29** showed one resonance for the H-14 hydrogen atom, and one for the silyl substituent at C-13. The 13, 21-bis-silyl *ortho* esters **23–26** showed one resonance for the H-14 hydrogen atom, and two resonances for the silyl substituents at the C-13 and C-21 oxygen atoms, respectively, (Table 2).

(b):  $^{13}\text{C}$  NMR evidences. The structures of the 13-oxo-*ortho* esters **21**, **22**, and **27** were supported by the relevant  $^{13}\text{C}$  NMR resonances (Table 3) of the keto group at C-13, in the range of 198.0–201.7 ppm, the *ortho* ester group at C-21 (117.5–120.8 ppm), and the  $\text{CH}_2$  at C-14 (41.3–42.4 ppm). The structures of the 13-enol derivatives **3**, **28**, and **29** were supported by the resonances of the  $\text{O}-\text{C}=\text{CH}$  carbon atom at C-13 (153.5 ppm), the  $\text{O}-\text{C}=\text{CH}$  enolic carbon atom at C-14 (110.6 ppm), and the  $\text{C}_6\text{H}_5\text{C}=\text{O}$  at C-2 (166.7–166.9 ppm). The structures of the 13-enol *ortho* esters **24–26** were supported by the resonances of the  $\text{O}-\text{C}=\text{CH}$  enolic carbon atom at C-13 (152.6–155.9 ppm), the  $\text{O}-\text{C}=\text{CH}$  enolic carbon atom at C-14 (110.9–115.4 ppm), and the *ortho* ester group at C-21 (118.5–121.7 ppm).

(c) ASIS effect. The ASIS effect of the C-21 phenyl substituent on the absorptions of H-2, H-14, H-14', H-3, Me-19, and Me-16 protons (Table 2) was a proper tool for the stereochemical assessment at C-21 of *ortho* esters **21–26**. In fact, the relative positions of these resonances of the 21- $\alpha/\beta$  epimers are explained by the shielding effect of the phenyl substituent, which is located in the  $\alpha$ -face of the C-21 carbon atom of the 21 $\beta$ -OTMS epimers **21**, **23**, and **25**, and in the  $\beta$ -face of the 21 $\alpha$ -OTMS epimers **22**, **24** and **26**. In particular, the following trends were observed: (i) ASIS

effect on the H-14 protons. These protons are located on the  $\alpha$ -face, being *syn* to the phenyl group of the 21 $\beta$ -OTMS epimers. Hence, the two H-14 protons of the  $\beta$ -epimer **21** absorbed at higher field (2.53 and 2.29 ppm) with respect to those of its  $\alpha$ -epimer **22** (3.07 and 2.91 ppm). Similarly, the H-14 protons of the  $\beta$ -epimers **23** and **25** absorbed at higher field (4.46 ppm) with respect to those of the  $\alpha$ -epimers **24** and **26** (5.42 and 5.36 ppm, respectively). (ii) ASIS effect on the H-3 protons. The H-3 protons of the 21 $\beta$ -OTMS epimers **21**, **23**, and **25** absorbed at higher field with respect to those of the  $\alpha$ -epimers **22**, **24**, and **29**. since this proton and the phenyl substituent are both located in the  $\alpha$ -face. (iii) ASIS effect on the H-2 protons. The trends on the H-2 protons, are opposite to those of H-14 and H-3 because this proton is located in the opposite  $\beta$ -face. (iv) ASIS effect on the Me-19 and Me-16. The Me-16 and Me-19 substituents are located on the  $\alpha$ -face and for this reason behave similarly to the H-2 protons. In particular, the Me-16 protons of the  $\beta$ -epimers **21**, **23**, and **25** absorbed at lower field (1.20, 1.15, and 1.17 ppm, respectively) with respect to those of the  $\alpha$ -epimers **22**, **24**, and **26** (0.98, 0.80 and 0.80 ppm). Similarly, the Me-19 protons of the  $\beta$ -epimers **21**, **23**, and **25** absorbed at lower field (1.78, 1.78 and 1.79 ppm, respectively) with respect to those of the  $\alpha$ -epimers **22**, **24**, and **26** (1.65, 1.63 and 1.79 ppm). The  $\beta$ -stereochemistry of compound **27** was assigned on the basis that the H-2, H-14, H-14', H-3, Me-19, and Me-16 proton resonances were fully consistent with those of the  $\beta$ -epimeric 13-oxo *ortho* ester **21** instead of the  $\alpha$ -epimer **22**. In particular, the Me-16 and Me-19 resonances of **27** were typical of all  $\beta$ -epimers.

(d) Qualitative homonuclear NOE difference spectra studies. NOE difference spectra studies allowed the stereochemical assessment at the C-21 stereogenic center of the *ortho* esters **21–24**. The irradiation of the 21 $\beta$ -OTMS substituents of **21** and **23** (–0.03 and –0.01 ppm, respectively) caused a consistent enhancement (7–9%) of their corresponding H-2 protons, this suggesting that the TMSO group are located on the  $\beta$ -face. No enhancement of the H-2 protons was observed upon irradiation of the TMSO groups of **22** and **24**.

**Table 3.** Relevant  $^{13}\text{C}$  NMR resonances (C-13, C-14, C-21,  $\text{O}-\text{C}=\text{O}$  at C2) of 13-oxo *ortho* esters (**21**, **22**, and **27**), 13-silyl enol ethers (**3**, **28**, and **29**) and 13, 21-bis-enol *ortho* esters (**23–26**)

Resonances	<b>29</b>	<b>28</b>	<b>3</b>	<b>27</b>	<b>26</b>	<b>25</b>	<b>24</b>	<b>23</b>	<b>22</b>	<b>21</b>
C-13	153.5	153.5	153.5	198.0	152.6	153.0	155.9	156.3	201.7	201.4
C-14	110.6	110.6	110.6	42.4	112.9	110.9	115.4	114.2	41.3	41.3
C-21	—	—	—	117.5	118.5	118.6	121.7	—	120.8	120.8
$\text{O}-\text{C}=\text{O}$ at C <sub>2</sub>	166.7	166.9	166.9	—	—	—	—	—	—	—

## References and notes

- Abbreviations and Acronyms: 10-Deacetylbaaccatin (10-DAB), trimethylsilyl (TMS), triethylsilyl (TES), triisopropylsilyl (TIPS), *tert*-butoxycarbonyl (BOC), 1,8-Diazabicyclo[5.4.0]undec-7-ene (DBU), potassium hexamethyldisilazide (KHMDS), *m*-chloroperbenzoic acid (MCPBA), *N,O*-bis(trimethylsilyl) acetamide (BSA), di-*tert*-butyl dicarbonate (BOC<sub>2</sub>O), *N*-methylimidazole (MEIM), 4-dimethylamino-pyridine (DMAP), acetic anhydride (Ac<sub>2</sub>O), 2,3-dimethyl-3,4,5,6-tetrahydro-2-(1*H*)-pyrimidone (DMPU), *m*-chloroperbenzoic acid (mCPBA), *p*-toluenesulphonic acid (PTSA).
- (a) Marder-Karsenti, R.; Dubois, J.; Guenard, D.; Gueritte-Voegelein, F.; Potier, P. *Tetrahedron* **1995**, *51*, 1985–1994. (b) Appendino, G.; Jakupovic, J.; Cravotto, G.; Enriu, R.; Varese, M.; Bombardelli, E. *Tetrahedron Lett.* **1995**, *36*, 3233–3236.
- Ahn, Y. M.; Vander Velde, D. G.; Georg, G. I. *J. Org. Chem.* **2002**, *67*, 7140–7143.
- Kelly, R. C.; Wicnienski, N. A.; Gebhard, I.; Qualls, S. J.; Han, F.; Dobrowolski, P. J.; Eldon, G.; Nidy, E. G.; Roy, A.; Johnson, R. A. *J. Am. Chem. Soc.* **1996**, *118*, 919–920.
- Johnson, R. A.; Dobrowolski, P. J.; Nidy, E. G.; Gebhard, I.; Qualls, S. J.; Wicnienski, N. A.; Kelly, R. C.; Pitts, T. W.; Lopes, N. M.; DeKoning, T. F.; Speaker, S. J.; Weed, S. D.; McGovern, J. P.; Chidester, C. J. *J. Med. Chem.* **1997**, *40*, 2810–2812.
- Baldelli, E.; Battaglia, A.; Bombardelli, E.; Carezzi, G.; Fontana, G.; Gambini, A.; Gelmi, M. L.; Guerrini, A.; Pocar, D. *J. Org. Chem.* **2003**, *68*, 9773–9779.
- Fang, W. S.; Fang, Q. C.; Liang, X. T. *Chin. Chem. Lett.* **2001**, *12*, 675–678.
- (a) Yu, C.-Z.; Liu, Z.-Y. *Tetrahedron Lett.* **1997**, *38*, 4133–4136. (b) Marder-Karsenti, R.; Dubois, J.; Chiaroni, A.; Riche, C.; Guenard, D.; Gueritte, F.; Potier, P. *Tetrahedron* **1998**, *54*, 15833–15844. (c) Pinciroli, V.; Ceccarelli, W.; Fusar-Bassini, D.; Menichincheri, M.; Mongelli, N.; Vanotti, E. *Tetrahedron Lett.* **1996**, *37*, 9365–9368. (d) Uoto, K.; Takenoshita, H.; Ishiyama, T.; Terasawa, H.; Soga, T. *Chem. Pharm. Bull.* **1997**, *45*, 2093.
- (a) Ojima, I.; Slater, J. C.; Kuduk, S. D.; Takeuchi, C. S.; Gimi, R. H.; Sun, C.-M.; Park, Y. H.; Pera, P.; Veith, J. M.; Bernacki, R. J. *J. Med. Chem.* **1997**, *40*, 267–278. (b) Ojima, I.; Fenoglio, I.; Park, Y. H.; Pera, P.; Bernacki, R. J. *Bioorg. Med. Chem. Lett.* **1994**, *37*, 1571–1574. (c) Ojima, I.; Park, Y. H.; Sun, C.-M.; Fenoglio, I.; Appendino, G.; Pera, P.; Bernacki, R. J. *J. Med. Chem.* **1994**, *37*, 1408–1410. (d) Distefano, M.; Scambia, G.; Ferlini, C.; Saggini, C.; De Vincenzo, R.; Riva, A.; Bombardelli, E.; Ojima, I.; Fattorossi, A.; Panici, P. B.; Mancuso, S. *Int. J. Cancer* **1997**, *72*, 844–850. (e) Battaglia, A.; Bernacki, R. J.; Bertucci, C.; Bombardelli, E.; Cimitan, S.; Ferlini, C.; Fontana, G.; Guerrini, A.; Riva, A. *J. Med. Chem.* **2003**, *46*, 4822–4825.
- Ortaxel (IDN-5109, BAY 59-8862) is currently being developed by Bayer but was initially developed at the State University of New York (SUNY) in the USA, in conjunction with Indena (Sanofi-Synthelabo) in Italy. It is also in phase II development for non-small cell lung cancer, breast cancer and renal cancer. See also: (a) Minderman, H.; Brooks, T. A.; O'Loughlin, K. L.; Ojima, I.; Bernacki, R. J.; Baer, M. R. *Cancer Chemother. Pharmacol.* **2004**, *53*, 263–269. (b) Ferlini, C.; Ojima, I.; Distefano, M.; Gallo, D.; Riva, A.; Morazzoni, P.; Bombardelli, E.; Mancuso, S.; Scambia, G. *Curr. Med. Chem. Anti-Canc. Agents* **2003**, *3*, 133–138.
- Kingston, D. J. I. *J. Nat. Prod.* **2000**, 726–734 and references therein.
- Battaglia, A.; Baldelli, E.; Bombardelli, E.; Carezzi, G.; Fontana, G.; Gambini, A.; Gelmi, M. L.; Guerrini, A.; Pocar, D. *J. Org. Chem.* **2004**, *69*, 6610–6616.
- The structures of the present paper are drawn according to Miller and Kingston representation. It is worth noting that in this representation the Me-16 substituent of the C15 carbon atom is drawn with a thickened line, being *cis* to Me-19 and the H-2 proton. See: (a) Appendino, G. In *The Chemistry and Pharmacology of Taxol and Related Compounds*; Farina, V., Ed.; Elsevier: New York, 1995; and references therein. (b) Miller, R. W. *J. Nat. Prod.* **1980**, *43*, 425. (c) Kingston, D. G. I.; Molinero, A. A.; Rimoldi, J. M. In Herz, W., Kirby, G. W., Moore, R. E., Steglich, W., Tamm, C., Eds.; *Progress in the Chemistry of Organic Natural Products*; Springer: Vienna, 1993; Vol. 61, p 1.
- For the synthesis of 7-TES-13-oxo-baccatin II, see: (a) Greene, D. J.-N.; Guenard, D.; Gueritte-Voegelein, F.; Manganatal, L.; Potier, P. *J. Am. Chem. Soc.* **1988**, *110*, 5917–5919. (b) Chordia, M. D.; Kingston, D. G. I. *Tetrahedron* **1997**, *53*, 5699–5710. For the synthesis of 7-BOC-13-oxo-baccatin III see Ref. 6.
- (a) Kobayashi, S.; Yamashita, Y.; Ishitani, H. *Chem. Lett.* **1999**, *28*, 307–308. (b) Yamashita, Y.; Ishitani, H.; Kobayashi, S. *Can. J. Chem.* **2000**, *78*, 666–672.
- Doering, W. E.; De Puy, C. H. *J. Am. Chem. Soc.* **1953**, *75*, 5955–5957.
- Hennessy, M. J.; Ruckle, R.E., Jr.; Taber, D. F. *J. Org. Chem.* **1986**, *51*, 4077–4078.
- (a) Regitz, M.; Maas, G. In *Diazo Compounds, Properties and Synthesis*; Academic: New York, 1986; Charter 13. (b) Regitz, R. *Angew. Chem., Int. Ed. Engl.* **1967**, *6*, 733–749.
- (a) Kühlein, K.; Jensen, H. *Liebigs Ann. Chem.* **1974**, 369–402. (b) Evans, D. A.; Britton, T. C.; Ellman, J. A.; Dorow, R. L. *J. Am. Chem. Soc.* **1990**, *112*, 4011–4030.
- Only the encumbered trisyl azide afforded relatively stable and isolable tautomeric mixtures of *N*-trisyl triazenes. See Ref. 18b.
- The formation of *ortho* esters is seldom observed in taxane chemistry, being these compounds unstable and very easily hydrolysed. For example, an *ortho* ester derivative of paclitaxel was obtained when the DMAP induced carbonylation of taxol with BOC<sub>2</sub>O was attempted. See: (a) Kingston, D. G. I.; Chaudhary, A. G.; Chordia, M. D.; Gharpure, M.; Gunatilaka, A. A. L.; Higgs, P. I.; Rimoldi, J. M.; Samala, L.; Prakash, G. J.; Giannakakou, P.; Jiang, Y. Q.; Lin, C. M.; Hamel, E.; Long, B. H.; Fairchild, C. R.; Johnston, K. A. *J. Med. Chem.* **1998**, *41*, 3715–3726. (b) Kingston, D. G. I.; Jagtap, P. G. *Tetrahedron Lett.* **1999**, *40*, 189–192. (c) Kelly, R. C.; Wicnienski, N. A.; Gebhard, I.; Qualls, S. J.; Han, F.; Dobrowolski, P. J.; Nidy, E. G.; Johnson, R. A. *J. Am. Chem. Soc.* **1996**, *118*, 919–920.
- Taniguchi, Y.; Inanaga, J.; Yamaguchi, M. *Bull. Chem. Soc. Jpn.* **1981**, *3229*, 3. See also Ref. 3.
- Instead, chromatography on SiO<sub>2</sub> caused a partial solvolysis at C-21, which afforded a mixture of the reagent **1** (from **27**), and the 13-OTES-enol ether **28** (from **25**).
- Denmark, S. E.; Hammer, R. P.; Weber, E. J.; Habermas, K. L. *J. Org. Chem.* **1987**, *52*, 165–168.
- (a) Sommer, E.; Pincas, H. *Chem. Ber.* **1963**, *1915*, 48.

- (b) Grove, E. L.; Braman, R. S.; Combs, H. F.; Nicholson, S. R. *Anal. Chem.* **1962**, *34*, 682.
26. Magnus, P.; Barth, L. *Tetrahedron* **1995**, *51*, 11075–11086.
27. An identical failure was observed when the reduction of 7-TES- and 7-BOC-13-oxo-14 $\beta$ -OH-baccatins was attempted under identical conditions. See Refs. **6** and **7**.
28. Similarly, the reduction of 7-TES-13-oxo-14 $\beta$ -OH-baccatin III 1, 14-carbonate with sodium- and alkyl-boron hydrides gave the corresponding 7-TES-14 $\beta$ -OH-baccatin III 1,14-carbonate and its 13 $\beta$ -OH epimer. See Ref. **6**.
29. Pontiroli, A.; Bombardelli, E. PCT Int. Appl. 20020444161; *Chem. Abstr.* **2002**, *137*, 6295.
30. Kingston, D. G. I.; Chaudhary, A. G.; Gunatilaka, A. A. L.; Middleton, M. L. *Tetrahedron Lett.* **1994**, *35*, 4483–4484.
31. Preliminary results on in vitro studies of compounds 14 $\beta$ -amino taxanes **43–47** are reported in: Fontana, G.; Battaglia, A., Gelmi, M. L.; Baldelli, E.; G. Carezzi, G.; Contini, A., Bombardelli, E.; Manzotti, C., Bernacki, R. J.; Zucchetti, M. *228th ACS National Meeting, Philadelphia*, Poster Abstract # 755981, August 22–26, 2004.



# An isomerization-ring-closing metathesis strategy for the synthesis of substituted benzofurans

Willem A. L. van Otterlo,\* Garreth L. Morgans, Lee G. Madeley, Samuel Kuzvidza, Simon S. Moleele, Natalie Thornton and Charles B. de Koning

School of Chemistry, Molecular Sciences Institute, University of the Witwatersrand, PO Wits 2050, Johannesburg, South Africa

Received 14 March 2005; revised 16 May 2005; accepted 26 May 2005

Available online 20 June 2005

**Abstract**—Twelve substituted benzofurans were synthesized from their corresponding substituted 1-allyl-2-allyloxybenzenes using ruthenium-mediated *C*- and *O*-allyl isomerization followed by ring-closing metathesis.

© 2005 Elsevier Ltd. All rights reserved.

## 1. Introduction

The 1-benzofuran skeleton **1** is a well known structural unit in naturally occurring compounds (Fig. 1).<sup>1</sup> Examples of interesting natural products containing the benzofuran motif include khellin **2**, a potent coronary vasodilator, isolated from the seeds of *Ammi visnaga* L.<sup>2a</sup> In addition, the synthetic bis(khellin) analogue **3** has been used in the treatment of atherosclerosis.<sup>2b</sup> Other examples include the furocoumarin heraclenol **4** and the related compound, byakangelicin **5**, both isolated from the spring parsley *Cymopterus watsonii*<sup>3a</sup> or the plant *Ruta montana*.<sup>3b</sup>

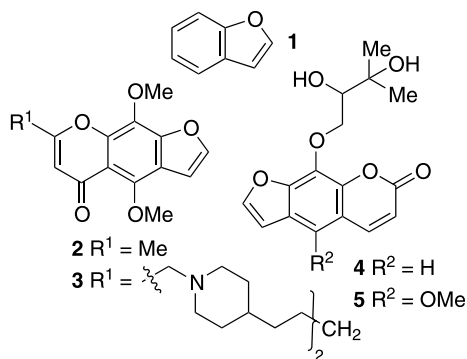


Figure 1.

The benzofuran building block has also been recognized as a ‘bicyclic privileged structure’ and several groups have

reported combinatorial approaches towards its synthesis.<sup>4</sup> Relevant medicinal chemistry examples include compound **6**, a potent and selective dopamine D-2 antagonist,<sup>5</sup> and compound **7**, a  $\kappa$ -selective agonist, with a potency 25 times greater than morphine (Fig. 2).<sup>6</sup>

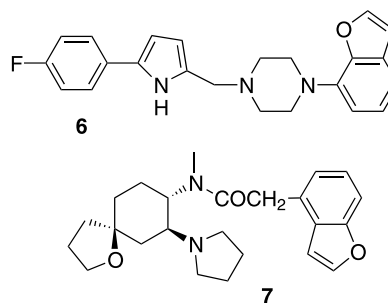


Figure 2.

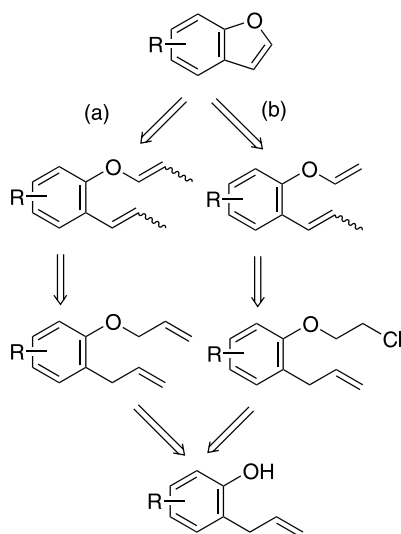
Owing to the obvious interest in this class of compounds,<sup>7</sup> many different approaches have been applied to their synthesis,<sup>8</sup> the most popular of these involving the use of a palladium-catalyzed cyclization reaction.<sup>9</sup> It is with this interest in mind that we report here a novel approach to the synthesis of benzofurans using a ruthenium-mediated isomerization reaction followed by a ring-closing metathesis (RCM) reaction.<sup>10</sup>

In recent years, the application of RCM to the synthesis of small ring systems has seen much activity and this research has been extensively reviewed.<sup>11</sup> The synthesis of 2-substituted benzofurans by titanium-mediated ester alkylation followed by molybdenum alkylidene-catalysed

**Keywords:** Benzofurans; Isomerization; Ring-closing metathesis.

\* Corresponding author. Tel.: +27 11 717 6707; fax: +27 11 717 6749; e-mail: willem@aurum.chem.wits.ac.za

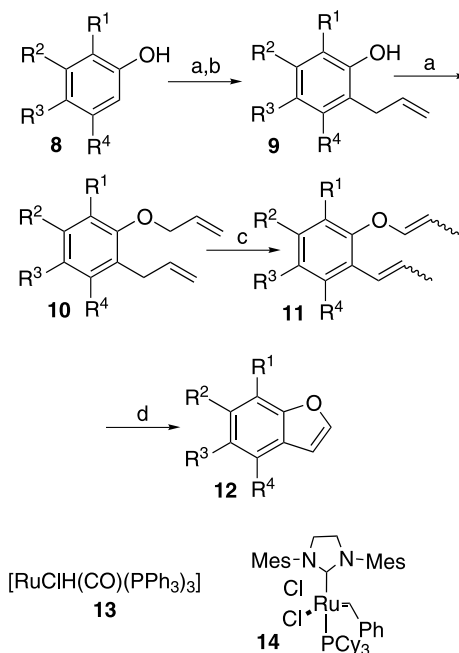
RCM has been reported by Grubbs and co-workers in 1994.<sup>12</sup> However, the application of ruthenium-mediated RCM to the synthesis of benzofurans has only been reported twice before.<sup>13</sup> In 2003, we published a communication that mentioned the synthesis of benzofuran using the bis-isomerization of a *C*-allyl and *O*-allyl group, followed by a RCM reaction (disconnection a, Fig. 3).<sup>13a</sup> The second report is that by Wang and co-workers who published a ruthenium-catalysed RCM approach to benzofurans in 2004.<sup>13b</sup> Their approach involved the installation of an *O*-vinyl aryl ether by way of a two-step alkylation-base-mediated elimination (disconnection b, Fig. 3). Subsequent metathesis then afforded the desired benzofurans.<sup>14</sup> Of interest is that the use of an isomerization reaction, normally of an aryl allyl group, prior to RCM has seen an increase in synthetic approaches.<sup>14,15</sup> Our present paper describes the extension of our work in which 12 substituted benzofurans have been synthesized, some bearing reactive functional groups, to demonstrate the feasibility of the isomerization-RCM approach.<sup>16</sup>



**Figure 3.** (a) This work and that first described in Ref.13a (b) Wang's route.<sup>13b</sup>

## 2. Results and discussion

Various substituted phenols **8** were initially converted into their corresponding aryl allyl ethers using allyl bromide and  $K_2CO_3$ . Subsequent microwave-assisted Claisen rearrangements then gave the substituted phenols **9** in acceptable yields over two steps (Scheme 1). These phenols were then re-allylated to afford the corresponding 1-allyl-2-allyloxybenzenes **10** in moderate to excellent yields (see Table 1 for respective yields). In the first important step, the two allyl groups were isomerized with the dependable ruthenium-based catalyst,  $[RuClH(CO)(PPh_3)_3]$  **13**. This catalyst and its application to allyl group isomerization has been popularized by the group of Krompiec, Kuźnik, Pigulla<sup>17</sup> and their co-workers and application of their methodology to our 1-allyl-2-allyloxybenzene substrates **10** readily afforded the aryl enol ethers **11**. The extent of reaction was monitored by  $^1H$  NMR spectroscopy and once the reaction was deemed to be complete, filtration through a short silica gel plug afforded the bis-isomerized compounds



**Scheme 1.** (a)  $K_2CO_3$ , allyl bromide, acetone; (b) microwave irradiation, neat, 100 W, 180–220 °C; (c) 5% catalyst **13**, toluene (or  $CH_2Cl_2$  for **10b**); (d) 5% catalyst **14**, toluene; For yields see Table 1.

**11** as a mixture of geometrical isomers. These compounds were not characterized any further and were used directly in the next reaction. Fortunately, the crucial ruthenium-mediated RCM reactions were mostly successful, using the second generation Grubbs metathesis catalyst **14**, affording the substituted benzofurans **12** in unoptimized yields ranging from 20 to 100%. From the  $^1H$  NMR spectra it was clear that the expected compounds had been formed, as shown by the presence of two sets of doublets at  $\delta = ca.$  6.8 ppm (3-H) and  $ca.$  7.5 ppm (2-H) with coupling constants of  $J = ca.$  2.2 Hz.

To the best of our knowledge, this isomerization-RCM sequence to afford the substituted benzofurans is novel in two aspects. Firstly, the isomerization of mixed *C*- and *O*-allyl systems is unprecedented and secondly the RCM of *C*-vinylic groups with *O*-vinylic groups has received little attention to the best of our knowledge. Literature searches have revealed that RCM using Grubbs' catalysts on

**Table 1.** Yields for Scheme 1

	8 → 10 <sup>a</sup>	10 → 11	11 → 12
<b>a</b> $R^1, R^4 = OMe, R^2, R^3 = H$	31%	99%	100%
<b>b</b> $R^1, R^3 = OMe, R^2, R^4 = H$	61%	100%	96%
<b>c</b> $R^1 = Ph, R^2, R^3, R^4 = H$	48%	98%	63%
<b>d</b> $R^1 = CHO, R^2, R^3, R^4 = H$	28%	57%	70%
<b>e</b> $R^1, R^2, R^4 = H, R^3 = CHO$	36%	82%	50%
<b>f</b> $R^1 = NO_2, R^2, R^3, R^4 = H$	62%	94%	82%
<b>g</b> $R^1, R^2, R^4 = H, R^3 = NO_2$	45%	85%	92%
<b>h</b> $R^1 = OMe, R^4 = CHO, R^2, R^3 = H$	36%	54%	50%
<b>i</b> $R^1, R^2, R^4 = H, R^3 = t\text{-butyl}$	50%	86%	70%
<b>j</b> $R^1, R^2, R^4 = H, R^3 = Br$	25%	100%	20%
<b>k</b> $R^1, R^2 = C_6H_4, R^3, R^4 = H$	85%	93%	92%
<b>l</b> $R^1, R^2 = H, R^3, R^4 = C_6H_4$	37%	<sup>b</sup>	31% <sup>c</sup>

<sup>a</sup> Yield over three steps.

<sup>b</sup> Compound not isolated.

<sup>c</sup> Yield over two steps.

substrates containing electron-rich vinylic olefins can be problematic<sup>18,12b</sup> and we were satisfied at the reasonable results afforded by the RCM of the bis-vinylic systems.

The metathesis cyclization methodology proved to be efficient for electron rich arene substituents such as in the synthesis of compounds **12a** and **12b**. Bulky groups *ortho* or *para* to the phenol group also did not seem to hamper the reaction (entries **12c** and **12l**). The electron-withdrawing nitro (entries **12f** and **12g**) and aldehyde groups (entries **12d**, **12e** and **12h**) also gave reasonable results. The advantage of these groups being tolerated in this process is that they are easily converted into a range of other functional groups, thus allowing for further structural modification on the benzofuran skeleton. One of the few disappointing entries in the tabulated results is entry **12j**; the allylated 4-bromophenol underwent extensive decomposition during the Claisen reaction and also gave a low yield during the RCM reaction (possibly further complicated by the high volatility of the 5-bromobenzofuran product **12j**). Finally, the isomerization-RCM methodology also proved efficient in synthesizing the two naphthofuran regioisomers **12i** and **12k**. Naphtho[2,1-*b*]furan **12k** was synthesized using a 'one-pot' isomerization-RCM strategy where the intermediate isomerized bis-allyl compound was not isolated. However, in our hands this method led to a disappointing yield of only 31%. In comparison, the synthesis of naphtho[1,2-*b*]furan **12k** over two separate steps from 2-allyl-1-allyloxynaphthalene **10k** was highly successful (85% over two steps). In most cases, the isomerization and metathesis reactions were performed in toluene so that the reaction times could be minimized (isomerization: overnight; metathesis: 3–4 h). However, to prove that a lower boiling point solvent could also be successfully used compound **10b** was isomerized in dichloromethane (48 h at reflux) to afford **11b** in quantitative yield. The RCM was then performed at ambient temperature in toluene to afford the required 5,7-dimethoxybenzofuran **12b** in excellent yield.

### 3. Conclusion

We have thus demonstrated a simple, versatile method for the synthesis of substituted benzofurans involving the novel isomerization of *C*- and *O*-allyl functional groups followed by a RCM reaction. The range of substituents tolerated by the methodology is reasonable, with aldehyde and nitro groups being important for further possible functional group manipulations.

### 4. Experimental

<sup>1</sup>H and <sup>13</sup>C NMR spectra were recorded either on a Bruker AC-200, Bruker 300 or Bruker DRX 400 spectrometer at the frequency indicated. All <sup>13</sup>C signals in the aromatic/alkene region have been assigned as quaternary (C) or non-quaternary (CH). Infrared spectra were recorded on either a Bruker IFS 25 Fourier Transform spectrometer or on a Bruker Vector 22 Fourier Transform spectrometer. Mass spectra were recorded on a Kratos MS 9/50, VG 70E MS or a VG 70 SEQ mass spectrometer. Macherey–Nagel kieselgel 60 (particle size 0.063–0.200 mm) was used for

conventional silica gel chromatography. All solvents used for reactions and chromatography were distilled prior to use. All microwave reactions were performed in a CEM Corporation Discover Focused Microwave Synthesis system.

#### 4.1. Precursors for the synthesis of the substituted benzofurans **12a-l**

2,5-Dimethoxyphenol **8a**, 2,4-dimethoxyphenol **8b**, biphenyl-2-ol **8c**, 2-hydroxybenzaldehyde **8d**, 4-hydroxybenzaldehyde **8e**, 2-nitrobenzene **8f**, 4-nitrobenzene **8g**, 3-hydroxy-4-methoxybenzaldehyde **8h**, 4-*tert*-butylphenol **8i**, 4-bromophenol **8j**, 2-naphthol **8k**, 1-naphthol **8l** were allylated to afford 2-allyloxy-1,4-dimethoxybenzene **15** (see below for experimental conditions), 1-allyloxy-2,4-dimethoxybenzene,<sup>19a</sup> 2-allyloxybiphenyl **16** (see below for experimental conditions), 2-allyloxybenzaldehyde,<sup>19b</sup> 1-allyloxybenzaldehyde,<sup>19c</sup> 1-allyloxy-2-nitrobenzene,<sup>19d</sup> 1-allyloxy-4-nitrobenzene,<sup>19e</sup> 3-allyloxy-4-methoxybenzaldehyde,<sup>19a</sup> 1-allyloxy-4-*tert*-butylbenzene,<sup>19f</sup> 1-allyloxy-4-bromobenzene,<sup>19g</sup> 2-allyloxynaphthalene<sup>19h</sup> and 1-allyloxynaphthalene,<sup>19i</sup> respectively. These compounds were subjected to microwave-assisted Claisen rearrangement at 180–220 °C to afford 2-allyl-3,6-dimethoxyphenol **9a** (see below for experimental conditions), 2-allyl-4,6-dimethoxyphenol **9b**, 3-allylbiphenyl-2-ol **9c** (see below for experimental conditions), 3-allyl-2-hydroxybenzaldehyde **9d**,<sup>19j</sup> 3-allyl-4-hydroxybenzaldehyde **9e** (see below for experimental conditions), 2-allyl-6-nitrophenol **9f**,<sup>13b</sup> 2-allyl-4-nitrophenol **9g** (see below for experimental conditions), 2-allyl-3-hydroxy-4-methoxybenzaldehyde **9h**,<sup>19d</sup> 2-allyl-4-*tert*-butylphenol **9i**,<sup>19f</sup> 2-allyl-4-bromophenol **9j**,<sup>19f</sup> 1-allyl-naphthalen-2-ol **9k**<sup>19h</sup> and 2-allyl-naphthalen-1-ol **9l**,<sup>19i</sup> respectively.

**4.1.1. 2-Allyloxy-1,4-dimethoxybenzene 15.** Allyl bromide (5.5 g, 45 mmol, 3.9 mL) and K<sub>2</sub>CO<sub>3</sub> (9.5 g, 69 mmol) were added to 2,4-dimethoxyphenol **8a** (5.0 g, 32 mmol) dissolved in dry acetone (500 mL). The reaction mixture was then heated at reflux under N<sub>2</sub> for 21 h. The resulting crude residue was then passed through a silica gel column (10% EtOAc/hexane) to afford 2-allyloxy-1,4-dimethoxybenzene **15** as a light yellow oil (3.7 g, 60%). (Found: M<sup>+</sup>, 194.0942, C<sub>11</sub>H<sub>14</sub>O<sub>3</sub> requires 194.0943). <sup>1</sup>H NMR (300 MHz, CDCl<sub>3</sub>): δ = 3.75 (3H, s, OCH<sub>3</sub>), 3.82 (3H, s, OCH<sub>3</sub>), 4.57–4.59 (2H, m, OCH<sub>2</sub>), 5.26–5.30 [1H, m, ArCH<sub>2</sub>CH=C(H)H], 5.37–5.43 [1H, m, ArCH<sub>2</sub>CH=C(H)H], 6.01–6.14 (1H, m, ArCH<sub>2</sub>CH=CH<sub>2</sub>), 6.40 (1H, dd, *J* = 8.7, 2.8 Hz, ArH), 6.52 (1H, d, *J* = 2.8 Hz, ArH), 6.79 (1H, d, *J* = 8.8 Hz, ArH); <sup>13</sup>C NMR (75 MHz, CDCl<sub>3</sub>): δ = 55.5 (OCH<sub>3</sub>), 56.6 (OCH<sub>3</sub>), 69.8 (OCH<sub>2</sub>), 102.2 (CH), 103.6 (CH), 112.6 (CH), 117.8 (CH), 133.3 (CH), 143.9 (C), 148.9 (C), 154.2 (C); ν<sub>max</sub> (CHCl<sub>3</sub>)/cm<sup>-1</sup>: 1610, 1602, 1510; MS: *m/z* = 195 (M<sup>+</sup> + 1, 55%), 194 (M<sup>+</sup>, 90), 153 (100), 125 (90), 110 (30), 79 (35), 69 (40), 52 (40), 41 (53).

**4.1.2. 2-Allyloxybiphenyl 16.** Allyl bromide (6.37 mL, 8.9 g, 7.4 mmol) and K<sub>2</sub>CO<sub>3</sub> (10.2 g, 7.4 mmol) were added to biphenyl-2-ol **8c** (5.0 g, 2.9 mmol) dissolved in acetone (100 mL) and the reaction slurry was then stirred at 60 °C for 20 h. After cooling, the base was removed by filtration through a Celite plug and the solvent was removed under reduced pressure. The brown residue was then purified using

silica gel column chromatography (EtOAc/hexane) to afford compound **16** as a yellow oil (6.2 g, 100%). (Found:  $M^+$ , 210.1054,  $C_{15}H_{14}O$  requires 210.1045).  $^1H$  NMR (300 MHz,  $CDCl_3$ ):  $\delta$ =4.50–4.52 (2H, m,  $ArOCH_2CHCH_2$ ), 5.16–5.26 [1H, m,  $ArOCH_2CHC(H)H$ ], 5.27–5.34 [1H, m,  $ArOCH_2CHC(H)H$ ], 5.90–6.02 (1H, m,  $ArOCH_2CHCH_2$ ), 6.94–7.04 (2H, m,  $2 \times ArH$ ), 7.19–7.45 (4H, m,  $4 \times ArH$ ), 7.54–7.57 (2H, m,  $2 \times ArH$ );  $^{13}C$  NMR (75 MHz,  $CDCl_3$ ):  $\delta$ =69.1 ( $ArOCH_2$ ), 113.0 (CH), 116.8 (CH), 121.1 (CH), 126.8 (CH), 127.9 ( $2 \times CH$ ), 128.5 (CH), 129.6 ( $2 \times CH$ ), 130.9 (CH), 131.1 (C), 133.3 (CH), 138.5 (C), 155.4 (C); IR  $\nu_{max}$  ( $CHCl_3$ )/ $cm^{-1}$ : 1638, 1590, 1497, 1458, 1433; MS:  $m/z$ =211 (17), 210 ( $M^+$ , 100%), 195 (12), 191 (11), 181 (18), 168 (14), 167 (20), 165 (29), 153 (13), 152 (21), 139 (10), 115 (21), 77 (13).

**4.1.3. 2-Allyl-3,6-dimethoxyphenol 9a.** 2-Allyloxy-1,4-dimethoxybenzene **15** (1.0 g, 5.2 mmol) was heated without solvent, under  $N_2$ , at 220–240 °C for 40 min. The dark brown residue was then subjected to purification by silica gel chromatography (20% EtOAc/hexane) to afford 2-allyl-3,6-dimethoxyphenol **9a** as a light oily semi-solid (0.49, 49%). (Found:  $M^+$ , 194.0943,  $C_{11}H_{14}O_3$  requires 194.0943).  $^1H$  NMR (300 MHz,  $CDCl_3$ ):  $\delta$ =3.43 (2H, br d,  $J$ =5.6 Hz,  $ArCH_2CHCH_2$ ), 3.76 (3H, s,  $OCH_3$ ), 3.82 (3H, s,  $OCH_3$ ), 4.92–5.07 (2H, m,  $ArCH_2CHCH_2$ ), 5.76 (1H, s, OH), 5.89–6.05 (1H, m,  $ArCH_2CHCH_2$ ), 6.33 (1H, d,  $J$ =8.8 Hz, ArH), 6.65 (1H, d,  $J$ =8.8 Hz, ArH);  $^{13}C$  NMR (75 MHz,  $CDCl_3$ ):  $\delta$ =27.4 ( $ArCH_2$ ), 55.8 ( $OCH_3$ ), 56.1 ( $OCH_3$ ), 100.9 (CH), 108.1 (CH), 114.1 (CH), 114.9 (C), 136.3 (CH), 141.0 (C), 144.2 (C), 152.4 (C);  $\nu_{max}$  ( $CHCl_3$ )/ $cm^{-1}$ : 3506 br, 1639, 1601, 1493, 1464, 1440; MS:  $m/z$ =195 ( $M^+$ +1.45%), 194 ( $M^+$ , 91), 179 (100), 151 (84), 147 (50), 136 (35), 123 (24), 119 (26), 91 (46), 79 (22), 77 (26), 65 (20), 53 (30), 39 (20).

**4.1.4. 3-Allylbiphenyl-2-ol 9c.** 2-Allyloxybiphenyl **16** (2.0 g, 9.5 mmol) was irradiated under microwave conditions (power: 100 W, ramp time: 2 °C per min, temperature: 200 °C, maximum pressure 100 psi) in a pressure tube. The irradiation was continued at 20 min intervals at, which time the extent of the reaction was checked by TLC. After a total irradiation time of 90 min the crude residue was purified by silica gel column chromatography (10% EtOAc/hexane) to afford the desired product **9c** as a clear yellow oil (1.2 g, 59%). (Found:  $M^+$ , 210.1062,  $C_{15}H_{14}O$  requires 210.1045).  $^1H$  NMR (300 MHz,  $CDCl_3$ ):  $\delta$ =3.47 (2H, br d,  $J$ =6.5 Hz,  $ArCH_2CHCH_2$ ), 5.09–5.31 (2H, m,  $ArCH_2CHCH_2$ ), 5.31 (1H, s, ArOH), 5.99–6.12 (1H, m,  $ArCH_2CHCH_2$ ), 6.91–6.96 (1H, m, ArH), 7.11–7.15 (2H, m,  $2 \times ArH$ ), 7.34–7.47 (5H, m,  $5 \times ArH$ );  $^{13}C$  NMR (75 MHz,  $CDCl_3$ ):  $\delta$ =34.8 ( $ArCH_2$ ), 115.9 (CH), 120.5 (CH), 126.4 (C), 127.8 (CH), 128.2 (C), 128.4 (CH), 129.2 ( $3 \times CH$ ), 129.3 (CH), 129.7 (CH), 136.6 (CH), 137.3 (C), 150.4 (C); IR  $\nu_{max}$  ( $CHCl_3$ )/ $cm^{-1}$ : 3062, 3025, 1649, 1597, 1584, 1504, 1481, 1455, 1434; MS:  $m/z$ =211 (12%), 210 ( $M^+$ , 63), 195 (13), 178 (12), 176 (35), 169 (100), 168 (23), 163 (18), 141 (38), 139 (21), 115 (37), 41 (10).

**4.1.5. 3-Allyl-4-hydroxybenzaldehyde 9e.** 4-Allyloxybenzaldehyde (1.18 g, 8.8 mmol) was irradiated with microwaves (50 W) in a pressurized capsule for 10 min to a maximum temperature of 250 °C. The dark residue was

purified with column chromatography (5–20% EtOAc/Hexane) to afford the desired product, 3-allyl-4-hydroxybenzaldehyde **9e** (0.48 g, 41%) as a yellow oil. (Found:  $M^+$ , 162.0684,  $C_{10}H_{10}O_2$  requires 162.0681).  $^1H$  NMR (300 MHz,  $CDCl_3$ ):  $\delta$ =3.47 (2H, br d,  $J$ =7.5 Hz,  $ArCH_2CHCH_2$ ), 5.13–5.19 (2H, m,  $ArCH_2CH=CH_2$ ), 5.96–6.09 (1H, m,  $ArCH_2CH=CH_2$ ), 6.97 (1H, d,  $J$ =8.4 Hz, 5-H), 6.99 (1H, s under previous doublet, OH), 7.67–7.70 (2H, m,  $2 \times ArH$ ), 9.83 (1H, s, CHO);  $^{13}C$  NMR (75 MHz,  $CDCl_3$ ):  $\delta$ =32.7 ( $ArCH_2$ ), 115.4 (CH), 114.8 (CH), 125.2 (C), 127.9 (C), 129.2 (CH), 130.9 (CH), 133.8 (CH), 158.8 (C), 190.0 (CHO); IR  $\nu_{max}$  ( $CHCl_3$ )/ $cm^{-1}$ : 3256 br, 1687, 1593;  $m/z$ =163 (69%), 162 ( $M^+$ , 100), 161 (90), 133 (55), 115 (38), 105 (49), 91 (37), 79 (36), 77 (50), 51 (31), 39 (33).

**4.1.6. 2-Allyl-4-nitrophenol 9g.** 4-Nitrophenol (1.17 g, 8.4 mmol) was irradiated with microwaves, (100 W, 215 °C, 15 min) to afford 2-allyl-4-nitrophenol **9g** (0.62 g, 53%) after chromatography as a dark solid (mp 70–72 °C). (Found:  $M^+$ , 179.0594,  $C_9H_9NO_3$  requires 179.0582).  $^1H$  NMR (300 MHz,  $CDCl_3$ ):  $\delta$ =3.47 (2H, br d,  $J$ =6.3 Hz,  $ArCH_2CHCH_2$ ), 5.18–5.26 (2H, m,  $ArCH_2CH=CH_2$ ), 5.94–6.08 (2H, m, ArOH and  $ArCH_2CH=CH_2$ ), 6.89 (1H, dd,  $J$ =9.4, 2.0 Hz, 3-H), 8.04–8.07 (2H, m,  $2 \times ArH$ );  $^{13}C$  NMR (75 MHz,  $CDCl_3$ ):  $\delta$ =34.6 ( $ArCH_2$ ), 115.8 (CH), 118.0 (CH), 124.3 (CH), 126.4 (CH), 126.5 (C), 134.6 (CH), 141.6 (C), 159.8 (C); IR  $\nu_{max}$  ( $CHCl_3$ )/ $cm^{-1}$ : 1640, 1616, 1591, 1521, 1494, 1435;  $m/z$ =180 (12%), 179 ( $M^+$ , 100), 149 (7), 133 (12), 132 (12), 118 (11), 103 (12), 79 (14), 77 (24), 65 (10), 51 (11), 39 (12).

## 4.2. General procedure for the allylation of substituted 2-allylphenols to produce 1-allyl-2-allyloxybenzenes

Allyl bromide (2 mol equiv) and  $K_2CO_3$  (2 mol equiv) were added to the phenol **9** (ca. 3 mmol) dissolved in acetone (100 mL) and the reaction slurry was then stirred at 60 °C for 2 h. After cooling, the base was removed by filtration and the solvent was removed under reduced pressure. The brown residue was then purified using silica gel column chromatography (EtOAc/hexane) to afford compound **10**. The following compounds were prepared using this procedure:

**4.2.1. 2-Allyl-3-allyloxy-1,4-dimethoxybenzene 10a.** The product **10a** (0.53 g, 93%) was obtained as a clear oil from **9a** (0.48 g, 2.4 mmol). (Found:  $M^+$ , 234.1258,  $C_{14}H_{18}O$  requires 234.1256).  $^1H$  NMR (300 MHz,  $CDCl_3$ ):  $\delta$ =3.42–3.45 (2H, m,  $ArCH_2CHCH_2$ ), 3.77 (3H, s,  $OCH_3$ ), 3.80 (3H, s,  $OCH_3$ ), 4.47–4.49 (2H, m,  $ArOCH_2CHCH_2$ ), 4.92–5.01 (2H, m,  $ArCH_2CHCH_2$ ), 5.20 [1H, dd,  $J$ =10.3, 1.4 Hz,  $ArOCH_2CHC(H)H$ ], 5.34–5.41 [1H, m,  $ArOCH_2CHC(H)H$ ], 5.90–6.16 (2H, m,  $ArOCH_2CHCH_2$  and  $ArCH_2CHCH_2$ ), 6.56 (1H, d,  $J$ =8.9 Hz, ArH), 6.73 (1H, d,  $J$ =8.9 Hz, ArH);  $^{13}C$  NMR (75 MHz,  $CDCl_3$ ):  $\delta$ =28.3 ( $ArCH_2$ ), 56.0 ( $OCH_3$ ), 56.3 ( $OCH_3$ ), 73.9 ( $ArOCH_2$ ), 105.6 (CH), 110.2 (CH), 114.4 (CH), 116.9 (CH), 123.3 (C), 134.5 (CH), 137.0 (CH), 146.9 (C), 147.3 (C), 152.3 (C); IR  $\nu_{max}$  ( $CHCl_3$ )/ $cm^{-1}$ : 1638, 1593, 1487, 1465, 1439; MS:  $m/z$ =234 ( $M^+$ , 100%), 220 (21), 219 (39), 193 (94), 165 (44), 163 (33), 150 (26), 135 (23), 133 (26), 130 (62), 118 (18), 100 (18), 91 (28), 79 (22), 77 (27), 69 (97), 41 (31).

**4.2.2. 1-Allyl-2-allyloxy-3,5-dimethoxybenzene 10b.** The product **10b** (1.0 g, 61%) was obtained as a yellow oil from **9b** (1.4 g, 7.1 mmol). (Found:  $M^+$ , 234.1258,  $C_{14}H_{18}O_3$  requires 234.1256).  $^1H$  NMR (300 MHz,  $CDCl_3$ ):  $\delta$  = 3.39 (2H, br d,  $J$  = 6.6 Hz,  $ArCH_2CHCH_2$ ), 3.76 (3H, s,  $OCH_3$ ), 3.82 (3H, s,  $OCH_3$ ), 4.40 (2H, br d,  $J$  = 5.7 Hz,  $ArOCH_2CHCH_2$ ), 5.03–5.11 (2H, m,  $ArCH_2CHCH_2$ ), 5.20 [1H, dd,  $J$  = 10.4, 1.3 Hz,  $ArOCH_2CHC(H)H$ ], 5.35 [1H, br dd,  $J$  = 17.2, 1.6 Hz,  $ArOCH_2CHC(H)H$ ], 5.88–6.15 (2H, m,  $ArOCH_2CHCH_2$  and  $ArCH_2CHCH_2$ ), 6.29 (1H, d,  $J$  = 2.9 Hz, ArH), 6.37 (1H, d,  $J$  = 2.9 Hz, ArH);  $^{13}C$  NMR (75 MHz,  $CDCl_3$ ):  $\delta$  = 34.5 ( $ArCH_2$ ), 55.5 ( $OCH_3$ ), 55.7 ( $OCH_3$ ), 74.0 ( $ArOCH_2$ ), 98.2 (CH), 105.0 (CH), 115.7 (CH), 117.0 (CH), 134.2 (C), 134.5 (CH), 137.1 (CH), 139.8 (C), 153.4 (C), 156.0 (C); IR  $\nu_{max}$  ( $CHCl_3$ )/ $cm^{-1}$ : 1638, 1600, 1489, 1466, 1424; MS:  $m/z$  = 234 ( $M^+$ , 20%), 193 (100), 165 (11), 161 (13), 135 (6), 133 (30), 118 (10), 105 (5), 91 (12), 79 (7), 65 (8), 41 (15).

**4.2.3. 3-Allyl-2-allyloxybiphenyl 10c.** The product **10c** (0.67 g, 81%) was obtained as a light yellow oil from **9c** (0.69 g, 3.3 mmol). (Found:  $M^+$ , 250.1360,  $C_{18}H_{18}O$  requires 250.1358).  $^1H$  NMR (300 MHz,  $CDCl_3$ ):  $\delta$  = 3.49 (2H, br d,  $J$  = 6.6 Hz,  $ArCH_2CHCH_2$ ), 3.91 (2H, br d,  $J$  = 5.7 Hz,  $ArOCH_2CHCH_2$ ), 5.04–5.14 (4H, m,  $ArCH_2CHCH_2$  and  $ArOCH_2CHCH_2$ ), 5.70–5.83 (1H, m,  $ArCH_2CHCH_2$ ), 5.96–6.10 (1H, m,  $ArOCH_2CHCH_2$ ), 7.09–7.29 (3H, m,  $3 \times ArH$ ), 7.32–7.42 (3H, m,  $3 \times ArH$ ), 7.56–7.59 (2H, m,  $2 \times ArH$ );  $^{13}C$  NMR (75 MHz,  $CDCl_3$ , one quaternary carbon not observable in spectrum):  $\delta$  = 34.4 ( $ArCH_2$ ), 73.7 ( $ArOCH_2$ ), 115.8 (CH), 117.2 (CH), 124.1 (CH), 127.1 (CH), 128.2 ( $2 \times CH$ ), 129.1 ( $2 \times CH$ ), 129.2 (CH), 129.4 (CH), 133.8 (CH), 135.1 (C), 137.4 (CH), 138.9 (C), 154.3 (C); IR  $\nu_{max}$  ( $CHCl_3$ )/ $cm^{-1}$ : 1638, 1600, 1498, 1459, 1431; MS:  $m/z$  = 250 ( $M^+$ , 55%), 235 (15), 221 (16), 214 (28), 209 (28), 194 (42), 181 (57), 178 (25), 175 (24), 168 (100), 166 (20), 165 (65), 153 (16), 152 (26), 139 (16), 132 (21), 115 (29), 77 (17), 41 (47).

**4.2.4. 3-Allyl-2-allyloxybenzaldehyde 10d.** The product **10d** (0.27 g, 77%) was obtained as a clear oil from **9d** (0.31 g, 1.9 mmol). (Found:  $M^+$ , 202.1001,  $C_{13}H_{14}O_2$  requires 202.0994).  $^1H$  NMR (300 MHz,  $CDCl_3$ ):  $\delta$  = 3.47 (2H, br d,  $J$  = 6.4 Hz,  $ArCH_2CHCH_2$ ), 4.46 (2H, br d,  $J$  = 5.7 Hz,  $ArOCH_2CHCH_2$ ), 5.06–5.15 (2H, m,  $ArCH_2CHCH_2$ ), 5.31 [1H, dd,  $J$  = 10.4, 1.0 Hz,  $ArOCH_2CHC(H)H$ ], 5.43 [1H, dd,  $J$  = 17.1, 1.4 Hz,  $ArOCH_2CHC(H)H$ ], 5.91–6.16 (2H, m,  $ArOCH_2CHCH_2$  and  $ArCH_2CHCH_2$ ), 7.17–7.22 (1H, m, ArH), 7.47 (1H, dd,  $J$  = 7.6, 1.6 Hz, ArH), 7.72 (1H, dd,  $J$  = 7.6, 1.6 Hz, ArH), 10.37 (1H, s, CHO);  $^{13}C$  NMR (75 MHz,  $CDCl_3$ , assignments with the same superscript may be interchanged):  $\delta$  = 33.3 ( $ArCH_2$ ), 77.5 ( $ArOCH_2$ ), 116.5 (CH), 118.5 (CH), 124.6 (CH), 126.9 (CH), 129.6 (C),<sup>a</sup> 132.6 (CH),<sup>a</sup> 134.4 (C),<sup>b</sup> 136.3 (CH),<sup>b</sup> 136.8 (CH), 160.1 (C), 190.3 (CHO); IR  $\nu_{max}$  ( $CHCl_3$ )/ $cm^{-1}$ : 1685, 1639, 1589, 1477, 1447; MS:  $m/z$  = 218 (57%), 202 ( $M^+$ , 58), 187 (22), 173 (20), 161 (75), 145 (35), 133 (77), 132 (80), 131 (89), 115 (50), 105 (43), 91 (33), 77 (52), 51 (31), 41 (100).

**4.2.5. 3-Allyl-4-allyloxybenzaldehyde 10e.** The product **10e** (0.86 g, 89%) was obtained as a pale oil from **9e** (0.90 g, 5.5 mmol). (Found:  $M^+$ , 202.0988,  $C_{13}H_{14}O_2$  requires

202.0994).  $^1H$  NMR (300 MHz,  $CDCl_3$ ):  $\delta$  = 3.45 (2H, br d,  $J$  = 6.7 Hz,  $ArCH_2CHCH_2$ ), 4.63–4.66 (2H, m,  $ArOCH_2CHCH_2$ ), 5.07–5.13 (2H, m,  $ArCH_2CHCH_2$ ), 5.32 [1H, dd,  $J$  = 10.6, 1.4 Hz,  $ArOCH_2CHC(H)H$ ], 5.44 [1H, dd,  $J$  = 17.3, 1.5 Hz,  $ArOCH_2CHC(H)H$ ], 5.95–6.11 (2H, m,  $ArOCH_2CHCH_2$  and  $ArCH_2CHCH_2$ ), 6.83 (1H, d,  $J$  = 8.2 Hz, ArH), 6.93 (1H, d,  $J$  = 8.2 Hz, ArH), 7.71 (1H, br s, ArH), 9.86 (1H, s, CHO);  $^{13}C$  NMR (75 MHz,  $CDCl_3$ ):  $\delta$  = 34.2 ( $ArCH_2$ ), 68.9 ( $ArOCH_2$ ), 111.2 (CH), 116.4 (CH), 117.7 (CH), 126.0 (C), 130.7 (CH), 131.0 (CH), 132.4 (CH), 133.1 (C), 135.7 (CH), 161.3 (C), 191.1 (CHO); IR  $\nu_{max}$  ( $CHCl_3$ )/ $cm^{-1}$ : 1689, 1639, 1595, 1492; MS:  $m/z$  = 203 (12%), 202 ( $M^+$ , 85), 162 (38), 161 (39), 159 (25), 135 (26), 133 (50), 132 (10), 115 (15), 105 (30), 103 (12), 91 (13), 79 (13), 77 (25), 51 (12), 41 (100), 39 (25).

**4.2.6. 1-Allyl-2-allyloxy-3-nitrobenzene<sup>19d</sup> 10f.** The product **10f** (0.13 g, 71%) was obtained as a dark orange oil from **9f** (0.15 g, 0.84 mmol).  $^1H$  NMR (300 MHz,  $CDCl_3$ ):  $\delta$  = 3.42 (2H, d,  $J$  = 6.4 Hz,  $ArCH_2CHCH_2$ ), 4.42 (2H, d,  $J$  = 5.8 Hz,  $ArOCH_2CHCH_2$ ), 4.99–5.09 (2H, m,  $ArCH_2CHCH_2$ ), 5.22 [1H, br d,  $J$  = 10.4 Hz,  $ArOCH_2CHC(H)H$ ], 5.32 [1H, dd,  $J$  = 17.2, 1.5 Hz,  $ArOCH_2CHC(H)H$ ], 5.84–6.04 (2H, m,  $ArOCH_2CHCH_2$  and  $ArCH_2CHCH_2$ ), 7.07–7.12 (1H, m, ArH), 7.37 (1H, d,  $J$  = 7.7 Hz, ArH), 7.61 (1H, dd,  $J$  = 8.1, 1.6 Hz, ArH);  $^{13}C$  NMR (75 MHz,  $CDCl_3$ , one quaternary carbon not observed):  $\delta$  = 30.9 ( $ArCH_2$ ), 76.0 ( $ArOCH_2$ ), 117.0 (CH), 118.7 (CH), 123.4 (CH), 123.9 (CH), 132.7 (CH), 134.9 (CH), 135.7 (C), 136.6 (C), 150.1 (C).

**4.2.7. 1-Allyl-2-allyloxy-3-nitrobenzene 10g.** The product **10g** (0.24 g, 93%) was obtained as an orange oil from **12e** (0.21 g, 1.2 mmol). The HRMS molecular ion was not observed as the expected mass of 219.0895 ( $C_{12}H_{13}NO_3$ ) was obscured by a reference compound fragment (perfluorotributylamine); however, the deallylated fragment was evident: (Found:  $M^+$ , 178.0517,  $C_9H_8NO_3$  requires 178.0504).  $^1H$  NMR (300 MHz,  $CDCl_3$ ):  $\delta$  = 3.45 (2H, br d,  $J$  = 6.7 Hz,  $ArCH_2CHCH_2$ ), 4.65–4.67 (2H, m,  $ArOCH_2CHCH_2$ ), 5.09–5.15 (2H, m,  $ArCH_2CHCH_2$ ), 5.30–5.47 (2H, m,  $ArOCH_2CHCH_2$ ), 5.91–6.11 (2H, m,  $ArOCH_2CHCH_2$  and  $ArCH_2CHCH_2$ ), 6.88 (1H, d,  $J$  = 8.9 Hz, 3-H), 8.06–8.13 (2H, m,  $2 \times ArH$ );  $^{13}C$  NMR (75 MHz,  $CDCl_3$ ):  $\delta$  = 34.1 ( $ArCH_2$ ), 69.3 ( $ArOCH_2$ ), 110.8 (CH), 117.0 (CH), 118.1 (CH), 123.9 (CH), 125.4 (CH), 130.1 (C), 132.0 (CH), 135.0 (CH), 141.3 (C), 161.2 (C); IR  $\nu_{max}$  ( $CHCl_3$ )/ $cm^{-1}$ : 1640, 1611, 1590, 1519, 1455, 1425, 1341; MS:  $m/z$  = 219 ( $M^+$ , 100%), 178 (13), 152 (4), 131 (29), 119 (5), 100 (8), 77 (9), 69 (70), 41 (71), 28 (69).

**4.2.8. 2-Allyl-3-allyloxy-4-methoxybenzaldehyde 10h.** The product **10h** (0.53 g, 93%) was obtained as a pale oil from **9h** (0.48 g, 2.4 mmol). (Found:  $M^+$ , 232.1085,  $C_{14}H_{16}O_3$  requires 232.1099).  $^1H$  NMR (300 MHz,  $CDCl_3$ ):  $\delta$  = 3.88 (2H, br d,  $J$  = 5.8 Hz,  $ArCH_2CHCH_2$ ), 3.93 (3H, s,  $OCH_3$ ), 4.47 (2H, br d,  $J$  = 5.7 Hz,  $ArOCH_2CHCH_2$ ), 4.89–5.04 (2H, m,  $ArCH_2CHCH_2$ ), 5.24 [1H, dd,  $J$  = 10.7, 1.1 Hz,  $ArOCH_2CHC(H)H$ ], 5.38 [1H, dd,  $J$  = 17.2, 1.4 Hz,  $ArOCH_2CHC(H)H$ ], 6.03–6.10 (2H, m,  $ArOCH_2CHCH_2$  and  $ArCH_2CHCH_2$ ), 6.92 (1H, d,  $J$  = 8.6 Hz, ArH), 7.65 (1H, d,  $J$  = 8.6 Hz, ArH), 10.06 (1H, s, CHO);  $^{13}C$  NMR (75 MHz,  $CDCl_3$ ):  $\delta$  = 28.9 ( $ArCH_2$ ), 55.8

(OCH<sub>3</sub>), 74.0 (ArOCH<sub>2</sub>), 109.8 (CH), 115.6 (CH), 117.5 (CH), 128.0 (C), 128.9 (CH), 133.9 (CH), 136.3 (CH), 137.0 (C), 146.1 (C), 157.5 (C), 190.9 (CHO); IR  $\nu_{\max}$  (CHCl<sub>3</sub>)/cm<sup>-1</sup>: 1682, 1586, 1441; MS:  $m/z$ =232 (M<sup>+</sup>, 37%), 217 (24), 191 (100), 190 (10), 175 (11), 164 (12), 163 (16), 148 (18), 135 (46), 120 (10), 105 (31), 103 (23), 91 (25), 77 (17), 65 (14), 43 (12), 41 (20), 39 (16).

**4.2.9. 2-Allyl-1-allyloxy-4-tert-butylbenzene<sup>19f</sup> 10i.** The product **10i** (0.57 g, 90%) was obtained as a yellow oil from **9i** (0.52 g, 2.7 mmol). <sup>1</sup>H NMR (300 MHz, CDCl<sub>3</sub>):  $\delta$ =1.29 [9H, s, C(CH<sub>3</sub>)<sub>3</sub>], 3.41 (2H, br d,  $J$ =6.6 Hz, ArCH<sub>2</sub>-CHCH<sub>2</sub>), 4.50–4.53 (2H, m, ArOCH<sub>2</sub>CHCH<sub>2</sub>), 5.01–5.10 (2H, m, ArCH<sub>2</sub>CHCH<sub>2</sub>), 5.23 [1H, dd,  $J$ =10.6, 1.6 Hz, ArOCH<sub>2</sub>CHC(H)H], 5.41 [1H, dd,  $J$ =17.3, 1.6 Hz, ArOCH<sub>2</sub>CHC(H)H], 6.00–6.06 (2H, m, ArOCH<sub>2</sub>CHCH<sub>2</sub> and ArCH<sub>2</sub>CHCH<sub>2</sub>), 6.76 (1H, d,  $J$ =9.2 Hz, ArH), 7.15–7.17 (2H, m, 2×ArH).

**4.2.10. 2-Allyl-1-allyloxy-4-bromobenzene 10j.** The product **10j** (0.42 g, 25%) was obtained as a light yellow oil from **9j** (1.4 g, 6.6 mmol). (Found: M<sup>+</sup>, 252.0133, C<sub>12</sub>H<sub>13</sub>OBr requires 252.0150). <sup>1</sup>H NMR (300 MHz, CDCl<sub>3</sub>):  $\delta$ =3.37 (2H, br d,  $J$ =6.7 Hz, ArCH<sub>2</sub>CHCH<sub>2</sub>), 4.50–4.52 (2H, m, ArOCH<sub>2</sub>CHCH<sub>2</sub>), 5.05–5.11 (2H, m, ArCH<sub>2</sub>CHCH<sub>2</sub>), 5.27 [1H, dd,  $J$ =10.6, 1.5 Hz, ArOCH<sub>2</sub>-CHC(H)H], 5.40 [1H, dd,  $J$ =17.3, 1.5 Hz, ArOCH<sub>2</sub>-CHC(H)H], 5.88–6.09 (2H, m, ArOCH<sub>2</sub>CHCH<sub>2</sub> and ArCH<sub>2</sub>CHCH<sub>2</sub>), 6.70 (1H, dd,  $J$ =5.6, 3.8 Hz, ArH), 7.25–7.27 (2H, m, 2×ArH); <sup>13</sup>C NMR (75 MHz, CDCl<sub>3</sub>):  $\delta$ =34.1 (ArCH<sub>2</sub>), 69.0 (ArOCH<sub>2</sub>), 112.9 (C), 113.3 (CH), 116.2 (CH), 117.3 (CH), 129.8 (CH), 131.3 (C), 132.5 (CH), 133.0 (CH), 136.0 (CH), 155.3 (C); IR  $\nu_{\max}$  (CHCl<sub>3</sub>)/cm<sup>-1</sup>: 1638, 1591, 1487, 1455, 1424, 1410; MS:  $m/z$ =254, (56%), 252 (M<sup>+</sup>, 56), 220 (31), 210 (37), 209 (20), 185 (18), 132 (100), 118 (19), 104 (33), 103 (17), 55 (14).

**4.2.11. 2-Allyl-1-allyloxynaphthalene 10k.** The product **10k** (0.86 g, 99%) was obtained as a yellow oil from **9k** (0.71 g, 3.9 mmol). (Found: M<sup>+</sup>, 224.1204, C<sub>16</sub>H<sub>16</sub>O requires 224.1201). <sup>1</sup>H NMR (300 MHz, CDCl<sub>3</sub>):  $\delta$ =3.60 (2H, d,  $J$ =br 6.4 Hz, ArCH<sub>2</sub>CHCH<sub>2</sub>), 4.50 (2H, dd,  $J$ =5.9, 0.9 Hz, ArOCH<sub>2</sub>CHCH<sub>2</sub>), 5.07–5.13 (2H, m, ArCH<sub>2</sub>-CHCH<sub>2</sub>), 5.32 [1H, br d,  $J$ =10.4 Hz, ArOCH<sub>2</sub>CHC(H)H], 5.51 [1H, br d,  $J$ =17.2 Hz, ArOCH<sub>2</sub>CHC(H)H], 5.97–6.10 (1H, m, ArCH<sub>2</sub>CHCH<sub>2</sub>), 6.14–6.27 (1H, m, ArOCH<sub>2</sub>-CHCH<sub>2</sub>), 7.32 (1H, d,  $J$ =8.5 Hz, ArH), 7.41–7.51 (2H, m, 2×ArH), 7.57 (1H, d,  $J$ =8.5 Hz, ArH), 7.81 (1H, d,  $J$ =7.8 Hz, ArH), 8.09 (1H, d,  $J$ =8.1 Hz, ArH); <sup>13</sup>C NMR (75 MHz, CDCl<sub>3</sub>, one quaternary carbon not observable in spectrum):  $\delta$ =34.0 (ArCH<sub>2</sub>), 75.3 (ArOCH<sub>2</sub>), 115.9 (CH), 117.3 (CH), 122.1 (CH), 124.0 (CH), 125.5 (CH), 125.9 (CH), 127.9 (CH), 128.3 (CH), 128.4 (C), 133.8 (CH), 133.9 (C), 137.2 (CH), 152.2 (C); IR  $\nu_{\max}$  (CHCl<sub>3</sub>)/cm<sup>-1</sup>: 1638, 1598, 1572, 1507, 1465; MS:  $m/z$ =224 (M<sup>+</sup>, 61%), 184 (15), 183 (100), 182 (17), 181 (25), 165 (57), 154 (12), 153 (28), 152 (23), 139 (11), 128 (25), 127 (19), 115 (20), 41 (11).

**4.2.12. 1-Allyl-2-allyloxynaphthalene 10l.** The product **10l** (0.15 g, 41%) was obtained as a clear oil from **9l** (0.30 g, 1.6 mmol). (Found: M<sup>+</sup>, 224.1212, C<sub>16</sub>H<sub>16</sub>O requires 224.1201). <sup>1</sup>H NMR (300 MHz, CDCl<sub>3</sub>):  $\delta$ =3.88 (2H, br d,  $J$ =5.9 Hz, ArCH<sub>2</sub>CHCH<sub>2</sub>), 4.66 (2H, dd,  $J$ =3.7, 1.3 Hz,

ArOCH<sub>2</sub>CHCH<sub>2</sub>), 4.98–5.03 (2H, m, ArCH<sub>2</sub>CHCH<sub>2</sub>), 5.26 [1H, dd,  $J$ =10.5, 0.8 Hz, ArOCH<sub>2</sub>CHC(H)H], 5.43 [1H, br d,  $J$ =17.2 Hz, ArOCH<sub>2</sub>CHC(H)H], 5.98–6.13 (2H, m, ArOCH<sub>2</sub>CHCH<sub>2</sub> and ArCH<sub>2</sub>CHCH<sub>2</sub>), 7.24 (1H, d,  $J$ =9.2 Hz, ArH), 7.30–7.35 (1H, m, ArH), 7.43–7.48 (1H, m, ArH), 7.71 (1H, d,  $J$ =9.0 Hz, ArH), 7.77 (1H, d,  $J$ =8.1 Hz, ArH), 7.94 (1H, d,  $J$ =8.5 Hz, ArH); <sup>13</sup>C NMR (75 MHz, CDCl<sub>3</sub>):  $\delta$ =29.3 (ArCH<sub>2</sub>), 70.3 (ArOCH<sub>2</sub>), 114.9 (CH), 115.1 (CH), 117.1 (CH), 121.7 (C), 123.4 (CH), 123.6 (CH), 126.2 (CH), 127.9 (CH), 128.4 (CH), 129.4 (C), 133.2 (C), 133.8 (CH), 136.7 (CH), 153.5 (C); IR  $\nu_{\max}$  (CHCl<sub>3</sub>)/cm<sup>-1</sup>: 1640, 1593, 1549, 1513, 1463, 1429; MS:  $m/z$ =225 (17%), 224 (M<sup>+</sup>, 100), 183 (60), 181 (22), 165 (30), 155 (62), 153 (22), 152 (16), 128 (17), 115 (13), 55 (6), 41 (8).

### 4.3. General procedure for the isomerization of substituted 1-allyl-2-allyloxybenzenes to produce 1-(prop-1-enyl)-2-(prop-1-enyloxy)benzenes

Typically, 1-allyl-2-allyloxybenzene **10** (ca. 1 mmol) and [RuClH(CO)(PPh<sub>3</sub>)<sub>3</sub>] **13** (5 mol%) were dissolved in distilled, degassed toluene (5 mL). The reaction was heated at 65 °C for 14 h and the completion of the reaction was confirmed by NMR spectroscopy of a crude sample. The reaction solution was purified by filtration through a short silica gel pad (5% EtOAc/hexane) and evaporated under reduce pressure to afford the product, **11**, as a mixture of *E,Z* isomers. The following compounds, some, which were used in the next reaction without further characterization, were prepared using this procedure, unless otherwise mentioned:

**4.3.1. 1,4-Dimethoxy-2-(prop-1-enyl)-3-(prop-1-enyloxy)benzene 11a.** The product **11a** (0.30 g, 99%) was obtained as a dark oil from **10a** (0.31 g, 1.3 mmol) and used without further characterization.

**4.3.2. 1,5-Dimethoxy-3-(prop-1-enyl)-2-(prop-1-enyloxy)benzene 11b.** 1-Allyl-2-allyloxy-3,5-dimethoxybenzene **10b** (0.21 g, 0.91 mmol) and [RuClH(CO)(PPh<sub>3</sub>)<sub>3</sub>] **13** (5 mol%) were dissolved in distilled, degassed CH<sub>2</sub>Cl<sub>2</sub> (10 mL). The reaction was stirred at 45 °C under N<sub>2</sub> for 48 h and the completion of the reaction was confirmed by NMR spectroscopy of a crude sample. The reaction solution was purified by filtration through a short silica gel pad (5% EtOAc/hexane) to afford the product, **11b**, after evaporation of the solvent. Compound **11b** (0.21 g, quantitative) was obtained as a clear oil as a mixture of *E,Z* isomers.

**4.3.3. 3-(Prop-1-enyl)-2-(prop-1-enyloxy)biphenyl 11c.** The product **11c** (0.23 g, 98%) was obtained as a dark oil from **10c** (0.24 g, 0.94 mmol). (Found: M<sup>+</sup>, 250.1333, C<sub>18</sub>H<sub>18</sub>O requires 250.1358); MS:  $m/z$ =250 (M<sup>+</sup>, 100%), 236 (21), 235 (98), 221 (64), 208 (26), 207 (37), 194 (80), 191 (26), 179 (22), 178 (50), 168 (21), 166 (28), 165 (89), 152 (46), 115 (41).

**4.3.4. 3-(Prop-1-enyl)-2-(prop-1-enyloxy)benzaldehyde 11d.** The product **11d** (0.13 g, 57%) was obtained as a yellow oil from **10d** (0.23 g, 1.1 mmol) and used without further characterization.

**4.3.5. 3-(Prop-1-enyl)-4-(prop-1-enyloxy)benzaldehyde 11e.** The product **11e** (0.41 g, 82%) was obtained as a

yellow oil from **10e** (0.50 g, 2.5 mmol) and used without further characterization.

**4.3.6. 1-Nitro-3-(prop-1-enyl)-2-(prop-1-enyloxy)-benzene 11f.** The product **11f** (0.47 g, 94%) was obtained as a dark oil from **10f** (0.50 g, 2.3 mmol). The compound **11f** was purified by chromatography through a short silica gel plug and was then immediately used in the subsequent RCM reaction.

**4.3.7. 4-Nitro-2-(prop-1-enyl)-1-(prop-1-enyloxy)-benzene 11g.** The product **11g** (0.15 g, 85%) was obtained as an orange oil from **10g** (0.17 g, 0.79 mmol) and used without further characterization.

**4.3.8. 4-Methoxy-2-(prop-1-enyl)-3-(prop-1-enyloxy)benzaldehyde 11h.** The product **11h** (0.27 g, 54%) was obtained as a light oil from **10h** (0.50 g, 2.2 mmol). The compound **11h** was purified by chromatography through a short silica gel plug and was then immediately used in the subsequent RCM reaction.

**4.3.9. 4-tert-Butyl-2-(prop-1-enyl)-1-(prop-1-enyloxy)benzene 11i.** The product **11i** (0.19 g, 86%) was obtained as a light oil from **10i** (0.22 g, 0.97 mmol). (Found:  $M^+$ , 230.1648,  $C_{16}H_{22}O$  requires 230.1671); MS:  $m/z$ =230 ( $M^+$ , 24%), 216 (17), 215 (100), 173 (7), 159 (13), 128 (8), 115 (11), 91 (9), 41 (13).

**4.3.10. 4-Bromo-2-(prop-1-enyl)-1-(prop-1-enyloxy)-benzene 11j.** The product **11j** (0.23 g, 100%) was obtained as a dark oil from **10j** (0.23 g, 0.92 mmol). (Found:  $M^+$ , 252.0150,  $C_{12}H_{13}OBr$  requires 252.0150); MS:  $m/z$ =254 (52%), 252 ( $M^+$ , 54), 239 (33), 237 (35), 225 (59), 223 (60), 218 (26), 210 (23), 198 (28), 196 (27), 173 (40), 158 (100), 145 (21), 144 (22), 132 (55), 130 (32), 116 (21), 115 (87), 103 (30), 89 (26), 69 (20), 63 (23), 41 (20).

**4.3.11. 2-(Prop-1-enyl)-1-(prop-1-enyloxy)naphthalene 11k.** The product **11k** (0.27 g, 93%) was obtained as a dark yellow oil from **10k** (0.29 g, 1.3 mmol). (Found:  $M^+$ , 224.1205,  $C_{16}H_{16}O$  requires 224.1201); MS:  $m/z$ =224 ( $M^+$ , 64%), 219 (45), 213 (26), 210 (16), 209 (94), 196 (17), 195 (100), 194 (17), 183 (15), 182 (15), 181 (38), 168 (34), 165 (57), 155 (27), 153 (24), 152 (34), 141 (17), 139 (21), 128 (23), 127 (18), 115 (30).

#### 4.4. General procedure for the RCM of substituted 1-(prop-1-enyl)-2-(prop-1-enyloxy)benzenes to benzofurans

Catalyst **14** (5 mol%) was added to compound **11** (ca. 0.5 mmol) dissolved in distilled degassed toluene (3–5 mL). The reaction mixture was then stirred at 90 °C for 3 h under  $N_2$ . After cooling, the reaction mixture was filtered through a Celite plug and the solvent was removed under vacuum. The dark oil was further purified by column chromatography (10% EtOAc/hexane) to afford product **12**. The following compounds were prepared using this procedure unless otherwise mentioned:

**4.4.1. 4,7-Dimethoxybenzofuran<sup>20</sup> 12a.** The product **12a** (0.13 g, 100%) was obtained as a low melting point solid

from **11a** (0.17 g, 0.71 mmol). (Found:  $M^+$ , 178.0644,  $C_{10}H_{10}O_3$  requires 178.0630).  $^1H$  NMR (300 MHz,  $CDCl_3$ ):  $\delta$ =3.89 (3H, s, OCH<sub>3</sub>), 3.96 (3H, s, OCH<sub>3</sub>), 6.53 (1H, d,  $J$ =8.5 Hz, ArH), 6.70 (1H, d,  $J$ =8.5 Hz, ArH), 6.86 (1H, d,  $J$ =2.1 Hz, 3-H), 7.55 (1H, d,  $J$ =2.1 Hz, 2-H);  $^{13}C$  NMR (75 MHz,  $CDCl_3$ , one quaternary carbon not observable in spectrum):  $\delta$ =55.8 (OCH<sub>3</sub>), 56.5 (OCH<sub>3</sub>), 102.7 (CH), 104.4 (CH), 106.8 (CH), 119.5 (C), 140.4 (C), 143.9 (CH), 147.6 (C); IR  $\nu_{max}$  ( $CHCl_3$ )/ $cm^{-1}$ : 1607, 1590, 1540, 1504, 1461; MS:  $m/z$ =178 ( $M^+$ , 65%), 163 (100), 135 (8), 120 (8), 92 (6), 76 (5), 63 (6).

**4.4.2. 5,7-Dimethoxybenzofuran 12b.** The product **12b** (0.16 g, 96%) was obtained as a clear oil from **11b** (0.21 g, 0.91 mmol). RCM was done in toluene at room temperature for 24 h with 6% catalyst **14**. (Found:  $M^+$ , 178.0639,  $C_{10}H_{10}O_3$  requires 178.0630).  $^1H$  NMR (300 MHz,  $CDCl_3$ ):  $\delta$ =3.83 (3H, s, OCH<sub>3</sub>), 3.97 (3H, s, OCH<sub>3</sub>), 6.45 (1H, d,  $J$ =2.2 Hz, ArH), 6.63 (1H, d,  $J$ =2.2 Hz, ArH), 6.69 (1H, d,  $J$ =2.0 Hz, 3-H), 7.58 (1H, d,  $J$ =2.0 Hz, 2-H);  $^{13}C$  NMR (75 MHz,  $CDCl_3$ ):  $\delta$ =55.8 (OCH<sub>3</sub>), 56.0 (OCH<sub>3</sub>), 94.5 (CH), 97.0 (CH), 107.0 (CH), 128.7 (C), 139.7 (C), 145.4 (CH), 145.6 (C), 156.8 (C); IR  $\nu_{max}$  ( $CHCl_3$ )/ $cm^{-1}$ : 1606, 1542, 1481, 1454, 1433; MS:  $m/z$ =179 (12%), 178 ( $M^+$ , 100), 163 (15), 149 (8), 135 (33), 133 (6), 132 (6), 120 (8), 92 (7), 77 (5), 76 (5).

**4.4.3. 7-Phenylbenzofuran 12c.** The product **12c** (0.051 g, 63%) was obtained as a yellow oil from **11c** (0.10 g, 0.42 mmol). (Found:  $M^+$ , 194.0711,  $C_{14}H_{10}O$  requires 194.0732).  $^1H$  NMR (300 MHz,  $CDCl_3$ ):  $\delta$ =6.83 (1H, d,  $J$ =2.2 Hz, 3-H), 7.32–7.52 (5H, m, 5×ArH), 7.58 (1H, dd,  $J$ =7.7, 1.1 Hz, ArH), 7.67 (1H, d,  $J$ =2.2 Hz, 2-H), 7.84–7.87 (2H, m, 2×ArH);  $^{13}C$  NMR (75 MHz,  $CDCl_3$ , one quaternary carbon not observable in spectrum):  $\delta$ =106.8 (CH), 120.4 (CH), 123.3 (CH), 123.8 (CH), 127.6 (CH), 128.5 (2×CH), 128.6 (2×CH), 129.3 (C), 136.5 (C), 145.0 (CH), 153.0 (C); IR  $\nu_{max}$  ( $CHCl_3$ )/ $cm^{-1}$ : 1668, 1596, 1542, 1499, 1474, 1451, 1412; MS:  $m/z$ =195 (17%), 194 ( $M^+$ , 100), 165 (53), 163 (10), 139 (12), 115 (9), 63 (7).

**4.4.4. Benzofuran-7-carbaldehyde<sup>21</sup> 12d.** The product **12d** (0.048 g, 70%) was obtained as a clear oil from **11d** (0.095 g, 0.47 mmol). (Found:  $M^+$ , 146.0374,  $C_9H_6O_2$  requires 146.0368).  $^1H$  NMR (300 MHz,  $CDCl_3$ ):  $\delta$ =6.86 (1H, d,  $J$ =2.2 Hz, 3-H), 7.36–7.41 (1H, m, ArH), 7.78 (1H, d,  $J$ =2.2 Hz, 2-H), 7.79–7.81 (1H, m, ArH), 7.87 (1H, dd,  $J$ =7.8, 1.0 Hz, ArH), 10.44 (1H, s, CHO);  $^{13}C$  NMR (75 MHz,  $CDCl_3$ ):  $\delta$ =106.3 (CH), 121.2 (C), 122.9 (CH), 126.2 (CH), 127.6 (CH), 129.1 (C), 146.2 (CH), 153.7 (C), 188.8 (CHO); IR  $\nu_{max}$  ( $CHCl_3$ )/ $cm^{-1}$ : 1699, 1607, 1541, 1477, 1431; MS:  $m/z$ =146 ( $M^+$ , 92%), 145 (100), 117 (33), 89 (44), 63 (33), 51 (7), 39 (12).

**4.4.5. Benzofuran-5-carbaldehyde<sup>22</sup> 12e.** The product **12e** (0.020 g, 50%) was obtained as a light coloured semi-solid from **11e** (0.060 g, 0.30 mmol). (Found:  $M^+$ , 146.0369,  $C_{10}H_8O_2$  requires 146.0369).  $^1H$  NMR (300 MHz,  $CDCl_3$ ):  $\delta$ =6.88–6.89 (1H, m, 3-H), 7.61 (1H, d,  $J$ =8.5 Hz, 7-H), 7.72 (1H, d,  $J$ =2.2 Hz, 2-H), 7.87 (1H, dd,  $J$ =8.5, 1.6 Hz, 6-H), 8.14 (1H, d,  $J$ =1.6 Hz, 4-H), 10.06 (1H, s, CHO);  $^{13}C$  NMR (75 MHz,  $CDCl_3$ ):  $\delta$ =107.6 (CH), 112.6 (CH), 125.0

(CH), 126.1 (CH), 128.4 (C), 132.7 (C), 147.1 (CH), 158.7 (C), 192.1 (CHO); IR  $\nu_{\max}$  (CHCl<sub>3</sub>)/cm<sup>-1</sup>: 1693, 1609, 1587, 1540; MS:  $m/z$  = 146 (M<sup>+</sup>, 95%), 145 (100), 117 (53), 89 (35), 63 (22).

**4.4.6. 7-Nitrobenzofuran<sup>5</sup> 12f.** The product **12f** (0.22 g, 82%) was obtained as a dark oily solid from **11f** (0.36 g, 1.6 mmol). <sup>1</sup>H NMR (300 MHz, CDCl<sub>3</sub>):  $\delta$  = 6.94 (1H, d,  $J$  = 2.2 Hz, 3-H), 7.36–7.41 (1H, m, ArH), 7.85 (1H, d,  $J$  = 2.2 Hz, 2-H), 7.94 (1H, dd,  $J$  = 7.8, 0.8 Hz, ArH), 8.17 (1H, d,  $J$  = 8.2 Hz, ArH); <sup>13</sup>C NMR (75 MHz, CDCl<sub>3</sub>, one quaternary carbon not observable in spectrum):  $\delta$  = 106.9 (CH), 120.9 (CH), 122.8 (CH), 126.5 (C), 128.2 (CH), 128.7 (C), 147.3 (CH); IR  $\nu_{\max}$  (CHCl<sub>3</sub>)/cm<sup>-1</sup>: 1609, 1525, 1466, 1350.

**4.4.7. 5-Nitrobenzofuran<sup>23</sup> 12g.** The product **12g** (0.072 g, 92%) was obtained as a semi-solid from **11g** (0.10 g, 0.48 mmol). The HRMS molecular ion was not found as the expected mass of 163.0269 (C<sub>8</sub>H<sub>5</sub>NO<sub>3</sub>) was obscured by a reference compound fragment (perfluorotriethylamine). <sup>1</sup>H NMR (300 MHz, CDCl<sub>3</sub>):  $\delta$  = 6.93 (1H, d,  $J$  = 2.3 Hz, 3-H), 7.57 (1H, d,  $J$  = 9.0 Hz, 7-H), 7.79 (1H, d,  $J$  = 2.2 Hz, 4-H), 8.22 (1H, dd,  $J$  = 9.0, 2.3 Hz, 6-H), 8.53 (1H, d,  $J$  = 2.2 Hz, 2-H); <sup>13</sup>C NMR (75 MHz, CDCl<sub>3</sub>):  $\delta$  = 107.5 (CH), 111.7 (CH), 117.8 (CH), 120.1 (CH), 127.8 (C), 144.1 (C), 148.0 (CH), 157.6 (C); IR  $\nu_{\max}$  (CHCl<sub>3</sub>)/cm<sup>-1</sup>: 1620, 1594, 1541, 1507, 1446, 1359; MS:  $m/z$  = 163 (M<sup>+</sup>, 100%), 149 (5), 133 (9), 117 (31), 105 (5), 89 (39), 69 (10), 63 (21), 43 (10).

**4.4.8. 7-Methoxybenzofuran-4-carbaldehyde 12h.** The product **12h** (0.09 g, 50%) was obtained as light oil from **11h** (0.24 g, 0.10 mmol). (Found: M<sup>+</sup>, 176.0460, C<sub>10</sub>H<sub>8</sub>O<sub>3</sub> requires 176.0473). <sup>1</sup>H NMR (300 MHz, CDCl<sub>3</sub>):  $\delta$  = 4.10 (3H, s, OCH<sub>3</sub>), 6.91 (1H, d,  $J$  = 8.2 Hz, 6-H), 7.53 (1H, d,  $J$  = 2.0 Hz, 3-H), 7.68 (1H, d,  $J$  = 8.2 Hz, 5-H), 7.78 (1H, d,  $J$  = 2.0 Hz, 2-H), 10.05 (1H, s, CHO); <sup>13</sup>C NMR (75 MHz, CDCl<sub>3</sub>):  $\delta$  = 56.4 (OCH<sub>3</sub>), 105.8 (CH), 107.2 (CH), 123.2 (C), 127.9 (C), 131.8 (CH), 144.4 (C), 147.5 (CH), 150.2 (C), 190.6 (CHO); IR  $\nu_{\max}$  (CHCl<sub>3</sub>)/cm<sup>-1</sup>: 1684, 1624, 1540, 1500; MS:  $m/z$  = 176 (M<sup>+</sup>, 100%), 175 (83), 147 (12), 105 (8), 89 (9), 77 (10), 51 (8).

**4.4.9. 5-tert-Butyl-benzofuran<sup>24</sup> 12i.** The product **12i** (0.055 g, 70%) was obtained as a clear oil from **11i** (0.10 g, 0.44 mmol). (Found: M<sup>+</sup>, 174.1029, C<sub>12</sub>H<sub>14</sub>O requires 174.1045). <sup>1</sup>H NMR (300 MHz, CDCl<sub>3</sub>):  $\delta$  = 1.38 [9H, s, C(CH<sub>3</sub>)<sub>3</sub>], 6.73 (1H, d,  $J$  = 1.6 Hz, 3-H), 7.35 (1H, dd,  $J$  = 8.7, 1.9 Hz, 6-H), 7.43 (1H, d,  $J$  = 8.7 Hz, 7-H), 7.58–7.60 (2H, m, 2-H and 4-H); <sup>13</sup>C NMR (75 MHz, CDCl<sub>3</sub>):  $\delta$  = 27.4 [C(CH<sub>3</sub>)<sub>3</sub>], 31.9 (3 × CH<sub>3</sub>), 106.7 (CH), 110.6 (CH), 116.2 (C), 117.3 (CH), 122.2 (CH), 127.1 (C), 145.0 (CH), 145.8 (C); IR  $\nu_{\max}$  (CHCl<sub>3</sub>)/cm<sup>-1</sup>: 1699, 1607, 1541; MS:  $m/z$  = 174 (M<sup>+</sup>, 23%), 160 (12), 159 (100), 115 (16), 91 (14), 89 (7), 77 (6), 63 (6), 63 (7), 40 (9).

**4.4.10. 5-Bromobenzofuran<sup>25</sup> 12j.** The product **12j** (0.021 g, 20%) was obtained as a yellow oil from **11j** (0.15 g, 0.59 mmol). (Found: M<sup>+</sup>, 195.9516, C<sub>8</sub>H<sub>5</sub>OBr requires 195.9524). <sup>1</sup>H NMR (300 MHz, CDCl<sub>3</sub>):  $\delta$  = 6.73 (1H, d,  $J$  = 2.1 Hz, 3-H), 7.38–7.39 (2H, m, 2 × ArH), 7.62 (1H, d,  $J$  = 2.1 Hz, 2-H), 7.73 (1H, br s, ArH); <sup>13</sup>C NMR (75 MHz, CDCl<sub>3</sub>):  $\delta$  = 106.0 (CH), 112.8 (CH), 115.7 (C),

123.8 (CH), 127.1 (CH), 129.4 (C), 146.1 (CH), 153.7 (C); MS:  $m/z$  = 198 (72%), 196 (M<sup>+</sup>, 43), 194 (30), 180 (23), 165 (19), 149 (22), 132 (46), 115 (24), 111 (30), 109 (22), 97 (43), 89 (38), 85 (50), 83 (57), 82 (20), 81 (35), 72 (35), 71 (60), 70 (25), 69 (62), 67 (24), 63 (33), 57 (100), 55 (81), 43 (92), 41 (64).

**4.4.11. Naphtho[1,2-*b*]furan<sup>26</sup> 12k.** The product **12k** (0.27 g, 92%) was obtained as a yellow oil from **11k** (0.39 g, 1.7 mmol). (Found: M<sup>+</sup>, 168.0573, C<sub>12</sub>H<sub>8</sub>O requires 168.0575). <sup>1</sup>H NMR (300 MHz, CDCl<sub>3</sub>):  $\delta$  = 6.89 (1H, d,  $J$  = 2.1 Hz, 3-H), 7.45–7.50 (1H, m, ArH), 7.52–7.61 (1H, m, ArH), 7.65 (2H, br s, 2 × ArH), 7.75 (1H, d,  $J$  = 2.1 Hz, 2-H), 7.92 (1H, d,  $J$  = 8.1 Hz, ArH), 8.31 (1H, d,  $J$  = 8.1 Hz, ArH); <sup>13</sup>C NMR (75 MHz, CDCl<sub>3</sub>):  $\delta$  = 107.6 (CH), 119.7 (CH), 120.0 (CH), 121.5 (C), 122.9 (C), 123.4 (CH), 125.1 (CH), 126.3 (CH), 128.3 (CH), 131.4 (C), 144.1 (CH), 150.6 (C); IR  $\nu_{\max}$  (CHCl<sub>3</sub>)/cm<sup>-1</sup>: 1605, 1511, 1450; MS:  $m/z$  = 168 (M<sup>+</sup>, 61%), 139 (26), 130 (47), 100 (11), 69 (76).

**4.4.12. Naphtho[2,1-*b*]furan<sup>23</sup> 12l.** Isomerization catalyst **13** (1 mol%) was added to compound **10l** (0.13 g, 0.60 mmol) dissolved in distilled toluene (10 mL). The reaction mixture was then stirred at 80 °C for 4 h under N<sub>2</sub>. Catalyst **14** (5 mol%) was then added and the reaction mixture was heated at 80 °C for 12 h. After cooling, the reaction mixture was filtered through a Celite plug and the solvent was removed under vacuum. The resultant dark oil was further purified by column chromatography (2% EtOAc/hexane) to afford product **12l** (0.030 g, 31% over two steps) as a pale oily semi-solid. <sup>1</sup>H NMR (300 MHz, CDCl<sub>3</sub>):  $\delta$  = 7.25 (1H, d,  $J$  = 2.1 Hz, 2-H), 7.46–7.51 (1H, m, Ar-H), 7.56–7.61 (1H, m, Ar-H), 7.66 (1H, d,  $J$  = 9.0 Hz, Ar-H), 7.73 (1H, d,  $J$  = 9.0 Hz, Ar-H), 7.76 (1H, d,  $J$  = 2.1 Hz, 3-H), 7.95 (1H, d,  $J$  = 8.1 Hz, Ar-H), 8.14 (1H, d,  $J$  = 8.1 Hz, Ar-H); <sup>13</sup>C NMR (75 MHz, CDCl<sub>3</sub>):  $\delta$  = 105.6 (CH), 112.5 (CH), 122.6 (C), 123.4 (CH), 124.5 (CH), 125.2 (CH), 126.3 (CH), 127.8 (C), 128.7 (CH), 130.3 (C), 144.2 (CH), 152.5 (C); IR  $\nu_{\max}$  (CHCl<sub>3</sub>)/cm<sup>-1</sup>: 1628, 1582, 1516, 1458.

## Acknowledgements

This work was supported by the National Research Foundation (NRF, GUN 2053652), Pretoria, and the University of the Witwatersrand (University and Science Faculty Research Councils, Friedel Sellschop Award). Prof. J. P. Michael is thanked for many helpful discussions. We also gratefully acknowledge the Mellon Postgraduate Mentoring Programme (sponsored by the Andrew W. Mellon Foundation) for generous funding for Mr. S. S. Moleele. Mr. R. Mampa and Mr. T. van der Merwe are also thanked for providing the NMR and MS spectroscopy services, respectively. A referee is thanked for drawing our attention to relevant additional literature.

## References and notes

1. Keay, B. A.; Dibble, P. W. In *Furans and their Benzo Derivatives: Applications*; Katritzky, A. R., Rees, C. W.,



- Scriven, E. F. V., Eds.; *Comprehensive Heterocyclic Chemistry II*; Pergamon: Oxford, 1996; Vol. 2, pp 395–436.
- (a) Gammill, R. B.; Hyde, B. R. *J. Org. Chem.* **1983**, *48*, 3863–3865. (b) Gammill, R. B.; Bell, F. P.; Bell, L. T.; Bisaha, S. N.; Wilson, G. J. *J. Med. Chem.* **1990**, *33*, 2685–2687.
  - (a) Stermitz, F. R.; Thomas, R. D.; Williams, M. C. *Phytochemistry* **1975**, *14*, 1681–1681. (b) Kabouche, Z.; Benkiki, N.; Seguin, E.; Bruneau, C. *Fitoterapia* **2003**, *74*, 194–196.
  - Horton, D. A.; Bourne, G. T.; Smythe, M. L. *Chem. Rev.* **2003**, *103*, 893–930.
  - van Wijngaarden, I.; Kruse, C. G.; van der Heyden, J. A. M.; Tulp, M.; Th, M. *J. Med. Chem.* **1988**, *31*, 1934–1940.
  - Halfpenny, P. R.; Horwell, D. C.; Hughes, J.; Hunter, J. C.; Rees, D. C. *J. Med. Chem.* **1990**, *33*, 286–291.
  - For recent synthetic approaches to benzofurans see: (a) Bellur, E.; Freifeld, I.; Langer, P. *Tetrahedron Lett.* **2005**, *46*, 2185–2187. (b) Kim, K.-O.; Tae, J. *Synthesis* **2005**, 387–390. (c) Rama Rao, V. V. V. N. S.; Venkat Reddy, G.; Yadla, R.; Narsaiah, B.; Shanthan Rao, P. *Arkivoc* **2005**, 211–220. (d) Le Strat, F.; Harrowven, D. C.; Maddaluno, J. *J. Org. Chem.* **2005**, *70*, 489–498. (e) Konno, T.; Chae, J.; Ishihara, T.; Yamanaka, H. *Tetrahedron* **2004**, *60*, 11695–11700. (f) Thielges, S.; Meddah, E.; Bissere, P.; Eustache, J. *Tetrahedron Lett.* **2004**, *45*, 907–910. (g) Willis, M. C.; Taylor, D.; Gillmore, A. T. *Org. Lett.* **2004**, *6*, 4755–4757. (h) Xie, X.; Chen, B.; Lu, J.; Han, J.; She, X.; Pan, X. *Tetrahedron Lett.* **2004**, *45*, 6235–6237. (i) Yoshida, M.; Morishita, Y.; Fujita, M.; Ihara, M. *Tetrahedron Lett.* **2004**, *45*, 1861–1864.
  - Friedrichsen, W. In *Furans and their Benzo Derivatives: Synthesis*; Katritzky, A. R., Rees, C. W., Scriven, E. F. V., Eds.; *Comprehensive Heterocyclic Chemistry II*; Pergamon: Oxford, 1996; Vol. 2, pp 368–377.
  - For topical reviews see: (a) Zeni, G.; Larock, R. C. *Chem. Rev.* **2004**, *104*, 2285–2309. (b) Cacchi, S.; Fabrizi, G.; Goggioni, A. *Heterocycles* **2002**, *56*, 613–632.
  - Experimental work done by Mr. G. L. Morgans and the following Honours students: Mr. L. G. Madeley, Mr. S. Kuzvidza and Ms. N. Thornton [projects co-supervised by Mr. G. L. Morgans (PhD) and Mr. S. S. Molelele (PhD)].
  - For recent reviews on RCM see: (a) Deiters, A.; Martin, S. F. *Chem. Rev.* **2004**, *104*, 2199–2238. (b) McReynolds, M. D.; Dougherty, J. M.; Hanson, P. R. *Chem. Rev.* **2004**, *104*, 2239–2258.
  - (a) Fujimura, O.; Fu, G. C.; Grubbs, R. H. *J. Org. Chem.* **1994**, *59*, 4029–4031. (b) For a review including the description of carbonyl alkylidenation followed by RCM see: Hartley, R. C.; McKiernan, G. J. *J. Chem. Soc., Perkin Trans. 1* **2002**, 2763–2793.
  - (a) van Otterlo, W. A. L.; Ngidi, E. L.; de Koning, C. B. *Tetrahedron Lett.* **2003**, *44*, 6483–6486. (b) Tsai, T.-W.; Wang, E.-C.; Huang, K.-S.; Li, S.-R.; Wang, Y.-F.; Lin, Y.-L.; Chen, Y.-H. *Heterocycles* **2004**, *63*, 1771–1781.
  - For an interesting related *N*-allyl isomerization followed by a RCM leading to substituted indoles see: Arisawa, M.; Terada, Y.; Nakagawa, M.; Nishida, A. *Angew. Chem., Int. Ed.* **2002**, *41*, 4732–4734.
  - For other examples describing an isomerization process followed by RCM see: (a) Nguyen Van, T.; Debenedetti, S.; De Kimpe, N. *Tetrahedron Lett.* **2003**, *44*, 4199–4201. (b) Nguyen Van, T.; De Kimpe, N. *Tetrahedron Lett.* **2004**, *45*, 3443–3446. (c) Gross, J. L. *Tetrahedron Lett.* **2003**, *44*, 8563–8565. (d) Núñez, A.; Cuadro, A. M.; Alvarez-Builla, J.; Vaquero, J. *J. Org. Lett.* **2004**, *6*, 4125–4127. For an example, utilizing an isomerization to synthesize a number of RCM catalysts see: (e) Bujok, R.; Bieniek, M.; Masnyk, M.; Michrowska, A.; Sarosiek, A.; Stepowska, H.; Arlt, D.; Grela, K. *J. Org. Chem.* **2004**, *69*, 6894–6896. For an informative review including the relationship between metathesis and isomerization see: (f) Schmidt, B. *Eur. J. Org. Chem.* **2004**, 1865–1880.
  - For publications describing our previous isomerization-RCM strategies and related papers see: (a) van Otterlo, W. A. L.; Pathak, R.; de Koning, C. B. *Synlett* **2003**, 1859–1861. (b) van Otterlo, W. A. L.; Morgans, G. L.; Khanye, S. D.; Aderibigbe, B. A. A.; Michael, J. P.; Billing, D. G. *Tetrahedron Lett.* **2004**, *45*, 9171–9175. (c) van Otterlo, W. A. L.; Panayides, J.-L.; Fernandes, M. A. *Acta Crystallogr.* **2004**, *E60*, o1586–o1588. For related RCM methodology published by our group see: (d) van Otterlo, W. A. L.; Coyanis, E. M.; Panayides, J.-L.; de Koning, C. B.; Fernandes, M. A. *Synlett* **2005**, 501–505. (e) van Otterlo, W. A. L.; Ngidi, E. L.; de Koning, C. B.; Fernandes, M. A. *Tetrahedron Lett.* **2004**, *45*, 659–662. (f) van Otterlo, W. A. L.; Ngidi, E. L.; Coyanis, E. M.; de Koning, C. B. *Tetrahedron Lett.* **2003**, *44*, 311–313.
  - (a) Krompiec, S.; Kuźnik, N.; Bieg, T.; Adamus, B.; Majnusz, J.; Grymel, M. *Polish J. Chem.* **2000**, *74*, 1197–1200. (b) Krompiec, S.; Pigulla, M.; Bieg, T.; Szczepankiewicz, W.; Kuźnik, N.; Krompiec, M.; Kubicki, M. *J. Mol. Catal. A* **2002**, *189*, 169–185. (c) Krompiec, S.; Pigulla, M.; Krompiec, M.; Baj, S.; Mrowiec-Bialoń, J.; Kasperczyk, J. *Tetrahedron Lett.* **2004**, *45*, 5257–5261. (d) Krompiec, S.; Kuźnik, N.; Penczek, R.; Rzepa, J.; Mrowiec-Bialoń, J. *J. Mol. Catal. A* **2004**, *219*, 29–40.
  - (a) Chatterjee, A. K.; Morgan, J. P.; Scholl, M.; Grubbs, R. H. *J. Am. Chem. Soc.* **2000**, *122*, 3783–3784. (b) Sturino, C. F.; Wong, J. C. Y. *Tetrahedron Lett.* **1998**, *39*, 9623–9626.
  - (a) de Koning, C. B.; Michael, J. P.; van Otterlo, W. A. L. *J. Chem. Soc., Perkin Trans. 1* **2000**, 799–811. (b) Barkley, J. V.; Gilchrist, T. L.; Gonsalves, A. M. d’A. R.; Pinho e Melo, T. M. V. D. *Tetrahedron* **1995**, *51*, 13455–13460. (c) Khan, A. T.; Mondal, E.; Sahu, P. R. *Synlett* **2003**, 377–381. (d) Wang, E.-C.; Hsu, M.-K.; Lin, Y.-L.; Huang, K.-S. *Heterocycles* **2002**, *57*, 1997–2010. (e) Akiyama, R.; Kobayashi, S. *J. Am. Chem. Soc.* **2003**, *125*, 3412–3413. (f) Stäubli, B.; Fretz, H.; Piantini, U.; Woggon, W.-D. *Helv. Chim. Acta* **1987**, *70*, 1173–1193. (g) Kurosawa, W.; Kan, T.; Fukuyama, T. *J. Am. Chem. Soc.* **2003**, *125*, 8112–8113. (h) Gozzo, F. C.; Fernandes, S. A.; Rodrigues, D. C.; Eberlin, M. N.; Marsaioli, A. J. *J. Org. Chem.* **2003**, *68*, 5493–5499. (i) Kongkatip, N.; Kongkatip, B.; Siripong, P.; Sangma, C.; Luangkamin, S.; Niyomdech, M.; Pattanapa, S.; Piyaviriyagul, S.; Kongsaree, P. *Bioorg. Med. Chem.* **2003**, *11*, 3179–3191. (j) Hwang, S.-K.; Juhasz, A.; Yoon, S.-H.; Bodor, N. *J. Med. Chem.* **2000**, *43*, 1525–1532.
  - Cherif, M.; Cotellet, P.; Catteau, J.-P. *Heterocycles* **1992**, *34*, 1749–1758.
  - Benassi, R.; Folli, U.; Iarossi, D.; Schenetti, L.; Taddei, F. *J. Chem. Soc., Perkin Trans. 2* **1984**, 1479–1485.
  - Hiroya, K.; Hashimura, K.; Ogasawara, K. *Heterocycles* **1994**, *38*, 2463–2472.
  - Black, M.; Cadogan, J. I. G.; McNab, H.; MacPherson, A. D.; Roddam, V. P.; Smith, C.; Swenson, H. R. *J. Chem. Soc., Perkin Trans. 1* **1997**, 2483–2493.

24. Barker, P.; Finke, P.; Thompson, K. *Synth. Commun.* **1989**, *19*, 257–265.
25. Kelly, T. R.; Szabados, A.; Lee, Y.-J. *J. Org. Chem.* **1997**, *62*, 428–429.
26. Maeyama, K.; Iwasawa, N. *J. Org. Chem.* **1999**, *64*, 1344–1346.

# Synthesis and electrochemical characterization of dipyrroles separated by diphenyleneoxide and diphenylenesulfide spacers via the Trofimov reaction

Alexander M. Vasil'tsov,<sup>a</sup> Elena Yu. Schmidt,<sup>a</sup> Al'bina I. Mikhaleva,<sup>a,\*</sup> Nadezhda V. Zorina,<sup>a</sup> Alexey B. Zaitsev,<sup>a</sup> Olga V. Petrova,<sup>a</sup> Leonid B. Krivdin,<sup>a</sup> Konstantin B. Petrushenko,<sup>a</sup> Igor' A. Ushakov,<sup>a</sup> Cristina Pozo-Gonzalo,<sup>b</sup> José A. Pomposo<sup>b</sup> and Hans-Jürgen Grande<sup>b</sup>

<sup>a</sup>A. E. Favorsky Irkutsk Institute of Chemistry, Siberian Branch of the Russian Academy of Sciences, 1 Favorsky Str., Irkutsk 664033, Russian Federation

<sup>b</sup>CIDETEC, Centro de Investigación Tecnológica en Electroquímica, Paseo Miramón, 196, E-20009, San Sebastián, Spain

Received 11 March 2005; revised 11 May 2005; accepted 26 May 2005

Available online 22 June 2005

**Abstract**—4,4'-Bis[2-(1-vinylpyrrolyl)]diphenyloxide, 4,4'-bis(2-pyrrolyl)diphenylsulfide, 4-(2-pyrrolyl)-4'-[2-(1-vinylpyrrolyl)]diphenylsulfide and 4,4'-bis[2-(1-vinylpyrrolyl)]diphenylsulfide have been synthesized in a one-pot procedure from oximes of corresponding diacetylphenylenoxide and -sulfide through their reaction with acetylene in the MOH–DMSO systems (M=Li, K) at 80–130 °C under pressure of 10–15 atm, thus illustrating applicability and general character of the reaction of synthesis of diverse dipyrrole–phenylene assemblies and their *N*-vinyl derivatives. Two of the dipyrroles are promising for creating new conducting polymers with sulfur and oxygen atoms in the conjugation chain and for the study of the influence of the diphenyleneheteroatom moiety on conductivity of final polymer products. For the dipyrroles with the diphenyleneheteroatom moieties and 1,4-phenylene spacer the luminescence characteristics were determined.

© 2005 Elsevier Ltd. All rights reserved.

## 1. Introduction

Conjugated multi-ring monomers terminated with electron-rich heterocycles are electropolymerizable at lower potentials and with a minimum of side reactions leading to conjugated polymers with enhanced and better tunable properties.<sup>1</sup> In this connection a number of works were devoted to construction of dipyrroles separated by conjugated chains.<sup>1–4</sup> In spite of the fact that no general approaches were developed for creating dipyrroles separated by spacers comprising heteroatoms, conjugated polymers derived from such monomers might be of practical value due to their enhanced properties (e.g., widely used polyaniline<sup>5</sup> or its conducting sulfur-containing analogs with diphenylenesulfide bridges)<sup>6</sup> as well as of theoretical interest for study of the effects imposed by these atoms on conductivity.

**Keywords:** Dipyrroles; Diphenyleneoxide spacer; Diphenylenesulfide spacer; Dioximes; Acetylene; Superbase; Electropolymerization; Luminescence.

\* Corresponding author. Tel.: +7 3952 42 24 09/42 58 71; fax: +7 3952 41 93 46; e-mail: [mikh@irioch.irk.ru](mailto:mikh@irioch.irk.ru)

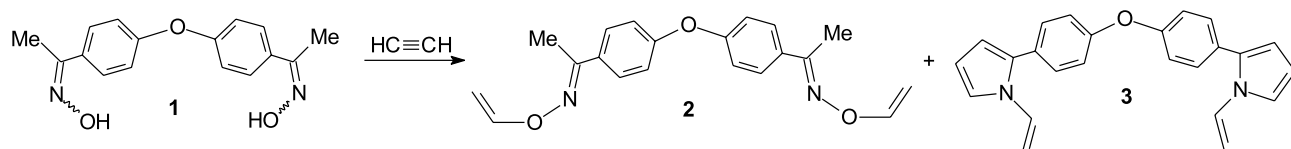
## 2. Results and discussion

### 2.1. Synthesis of dipyrroles separated by diphenyleneoxide and diphenylenesulfide spacers

Herein, we describe an approach to dipyrroles, separated by diphenyleneoxide and diphenylenesulfide spacers, from dioximes of the corresponding diacylaromatics: 4,4'-diacetyldiphenyloxide and 4,4'-diacetyldiphenylsulfide via the Trofimov reaction.<sup>7</sup> Previously, this reaction was successfully used for the synthesis of 1,4-bis[2-(1-vinylpyrrolyl)]benzene from 1,4-diacetylbenzene dioxime.<sup>8</sup> However, it was not clear how the longer aromatic spacers with oxygen and sulfur bridges will influence the reaction course.

The reaction of 4,4'-diacetyldiphenyloxide dioxime (**1**) with acetylene in KOH–DMSO system (120 °C, 1 h) afforded the expected divinylidipyrrole **3** (yield 27%), while under milder conditions (70 °C, 0.5 h) the intermediate bis(*O*-vinylloxime) **2** (yield 15%) was the only isolable product (Scheme 1).

4,4'-Diacetyldiphenylsulfide dioxime (**4**), has been prepared



Scheme 1.

by reacting the corresponding diketone with  $\text{NH}_2\text{OH}\cdot\text{HCl}$  in pyridine (80 °C, 6 h) with 99% yield. Its reaction with acetylene in the  $\text{LiOH}$ – $\text{DMSO}$  superbasic system (130 °C, 3 h, initial acetylene pressure 15 atm) gave the expected dipyrrole **5** (yield 8%) together with mono- (**6**) (yield 13%) and divinyl (**7**) (yield 6%) derivatives. This result does not correspond to those for all previously studied oximes, which under similar conditions in the same system selectively afford  $\text{NH}$ -pyrroles (Scheme 2).<sup>7,9</sup>

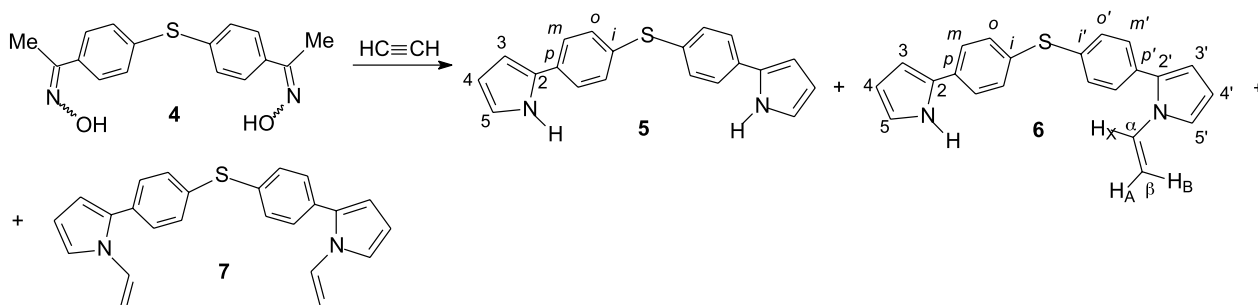
In the  $\text{KOH}$ – $\text{DMSO}$  system (110 °C, 1 h) under acetylene pressure (initial pressure 15 atm) the only product was divinyl dipyrrole **7** (14% non-optimized yield), while under atmospheric pressure (120 °C, 5 h) deoxygenation of **4** and autocondensation of the carbonyl derivatives leading to resinification prevailed and only traces of dipyrroles were identified by  $^1\text{H}$  NMR spectroscopy in the reaction mixture. A short contact of dioxime **4** with acetylene under pressure (90 °C, 5 min, initial pressure 15 atm) led to bis( $O$ -

vinyl)dioxime **8**, monopyrrole derivative **9** and dipyrrole **5** (12, 6, and 7% isolated yields, respectively) (Scheme 3).

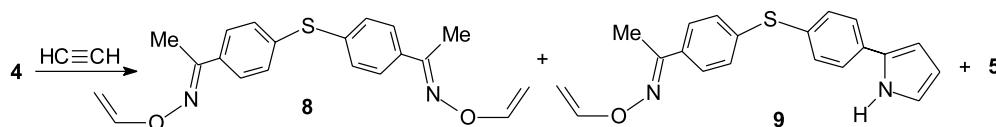
To selectively prepare dipyrrole **5** we attempted the thermal rearrangement of **8** and **9** in  $\text{DMSO}$  in a way similar to that described by Schmidt et al.<sup>10</sup> However, in this case the rearrangement to dipyrrole **5** proceeded at higher temperature (130 °C, 0.5 h), whereas at 120 °C (as in Ref. 10) **8** transformed only to **9**, but the latter failed to rearrange to **5**.

The following rationalization of this peculiar fact seems to be probable: the intermediate carbanion **A** (according to the accepted mechanism of the Trofimov reaction<sup>7</sup>) in the case of  $O$ -vinyl oxime with the pyrrole moiety **9** is additionally quenched with the acidic pyrrole protons, which are absent in the bis( $O$ -vinyl)dioxime **8**, that is, its rearrangement occurs under more aprotic conditions (Scheme 4).

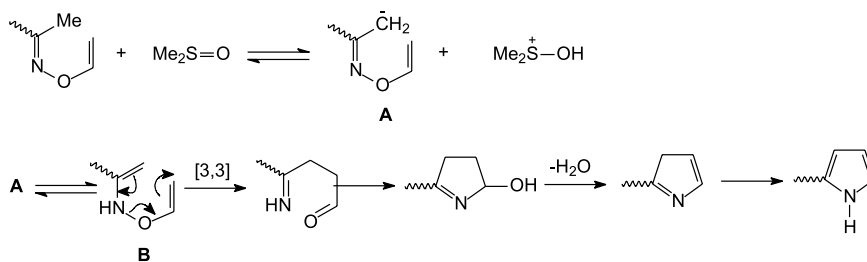
This slows down the formation of the next intermediate



Scheme 2.



Scheme 3.



Scheme 4.

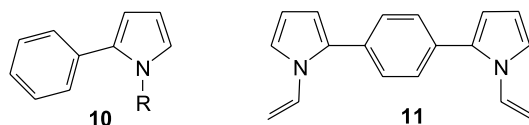
divinyl hydroxylamine **B** and hence, the proceeding steps leading to the pyrrole ring construction.

## 2.2. Absorption and emission properties of dipyrroles separated by diphenyleneoxide and diphenylenesulfide spacers

To estimate the role of the diphenyleneoxide and diphenylenesulfide spacers in transmission of excitation between pyrrole rings, we studied fluorescent properties of divinylpyrroles **3** and **7** in comparison with related mono-(2-phenylpyrrole **10a** and 2-phenyl-1-vinylpyrrole **10b**)<sup>9</sup> and dipyrrolic (4,4'-bis[2-(1-vinylpyrrolyl)]benzene **11**)<sup>8,9</sup> systems (Table 1). The quantum yield of **10a** was assigned to 1.

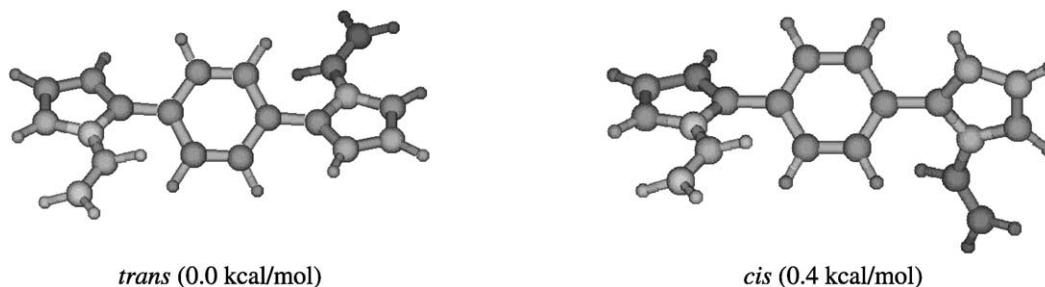
**Table 1.** Fluorescent properties of pyrrolic compounds

Compound	Absorbance, $\lambda_{\max}$ , nm		Fluorescence, $\lambda_{\max}$ , nm (quantum yield relative to <b>10a</b> )	
	<i>n</i> -C <sub>6</sub> H <sub>14</sub>	MeCN	<i>n</i> -C <sub>6</sub> H <sub>14</sub>	MeCN
<b>3</b>	283	287	350 (0.3)	364 (0.05)
<b>7</b>	304	304	363 (1.1)	(<0.01)
<b>10a</b>	289	287	322 (1.0)	350 (2.0)
<b>10b</b>	270	267	344 (0.7)	350 (0.2)
<b>11</b>	307	309	378 (2.9)	383 (2.4)



R = H (**10a**), CH=CH<sub>2</sub> (**10b**)

The essential decrease of fluorescence quantum yield on passing from **7** (1.1) to **3** (0.3) in *n*-hexane is probably



**Figure 1.** Rotational conformations of 1,4-bis[2-(1-vinylpyrrolyl)]benzene (**11**) optimized at the DFT-B3LYP/6-311G\* level. Relative energies are given in parentheses.

**Table 2.** UV and electrochemical data for compounds **3**, **7**, and **11**

Compound	$E_{1ox}^a$ (V)	$E_{2ox}^a$ (V)	$I_{rd}^a$ (V)	$\lambda_{\max}$ (nm) <sup>b</sup>
<b>3</b>	+1.22 <sup>c</sup>		-0.87 <sup>c</sup>	284
<b>7</b>	+1.08 <sup>c</sup>		-0.66 <sup>c</sup>	305
<b>11</b>	+0.97 <sup>c</sup>	+1.26 <sup>c</sup>	-1.60 <sup>c</sup>	310
Poly( <b>11</b> )	+0.60 <sup>c</sup>			482

<sup>a</sup> In acetonitrile.

<sup>b</sup> In dichloromethane.

<sup>c</sup> Irreversible peak.

caused by better internal conversion of excited states of **3** due to the decreased conjugation of oxygen with phenyl rings facilitating its internal rotation as compared to sulfur.

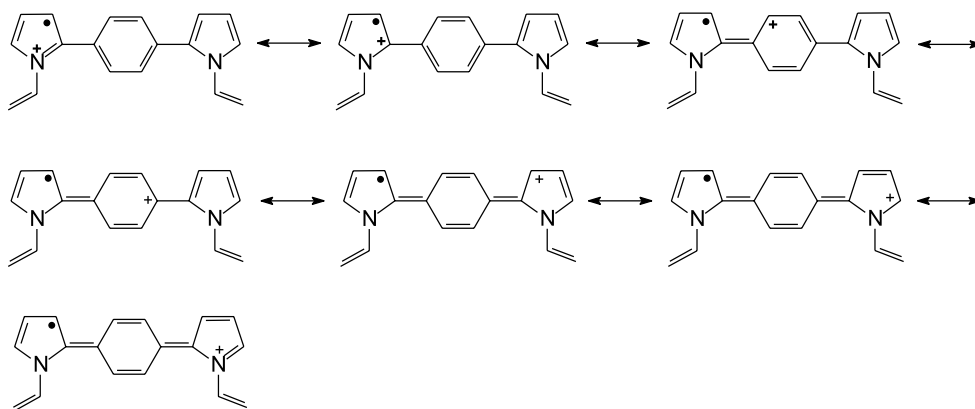
In much the same way, a hindered internal rotation of **11** is the reason for its high quantum yield (2.9). It is noteworthy that both rotational conformations of **11** depicted in Figure 1 as *cis* and *trans* are essentially non-planar with the pyrrole rings twisted out the benzene plane by ca. 44°. In its turn, the vinyl groups are twisted out the planes of the pyrrole rings by ca. 17° in both conformations. Apparently, the non-planarity of *cis* and *trans* conformations results in the noticeable hindrance of  $\pi,\pi$  as well as  $p,\pi$  conjugation. The energetic gap between *cis* and *trans* conformations is only ca. 0.4 kcal/mol, which implies essential population of the less stable *cis* form.

Thus, a better electronic conductivity should be expected for polymers containing diphenylenesulfide and 1,4-phenylene spacers as compared to those with diphenyleneoxide spacers.

The observed dramatic decrease of fluorescence quantum yields of **3** and **7** in acetonitrile solutions might be rendered by quenching of their polar excited states (charge transfer involving heteroatoms) by dipolar molecules of the solvent.

## 2.3. Electrochemistry of dipyrroles separated by diphenyleneoxide and diphenylenesulfide spacers

The redox behavior of compounds **3**, **7** and **11** were first characterized by cyclic voltammetry, using acetonitrile as the solvent and lithium perchlorate as the supporting electrolyte. For the *N*-vinyl pyrrole derivative **3** and **7** one irreversible oxidation wave was observed at +1.22 and +1.08 V, respectively. The derivative **11** exhibited two irreversible oxidation processes at +0.97 and +1.26 V (Table 2), which could be attributed to the oxidation of the



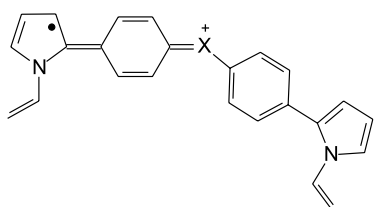
**Scheme 5.** Resonance structures of the radical cation of **11**.

pyrrole systems. It is noteworthy that the monomer *N*-vinylpyrrole has an oxidation potential of +0.6 V under similar conditions.<sup>11</sup> It was assumed that an increase in the degree of delocalization in poly(**11**) in comparison with the monomer would take place and therefore, a lowest oxidation process for poly(**11**) was expected. The disruption of the planarity within the aromatic systems could play an important role for an increase of the oxidation potential in the system and it has been supported by theoretical calculations. The derivative **11** exhibited the lowest oxidation potential in the series, probably due to a higher degree of electron delocalization in comparison with **3** and **7**.

It follows that the presence of the heteroatom (O and S, respectively), in the derivatives **3** and **7** could produce a  $\pi$  electron transmission blockage preventing the second oxidation process within the pyrrole ring. On the other hand, the value for the first oxidation process is quite high, therefore, the conditions for the second oxidation process are not favorable. The high degree of electron delocalization in derivative **11** could be the reason for the second oxidation process to take place. The possible resonance mechanisms for **11**, **3** and **7** are depicted in Schemes 5 and 6.

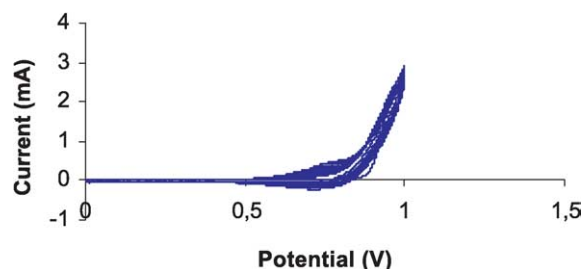
#### 2.4. Electropolymerization of dipyrroles separated by diphenyleneoxide and diphenylenesulfide spacers

Electropolymerization experiments were carried out for all derivatives **3**, **7**, and **11** (acetonitrile,  $10^{-3}$  M substrate, 0.1 M LiClO<sub>4</sub>, Ag/AgCl reference electrode), by repetitive scanning over the first oxidation wave at scan rate of 50 mV/s, using ITO glass or Pt as working electrode. Although, the electrodeposition experiments were carried out for all of them, only the derivative **11** succeeded in the electropolymerization process. The reason could be due to a favorable spin density distribution in the radical cation for

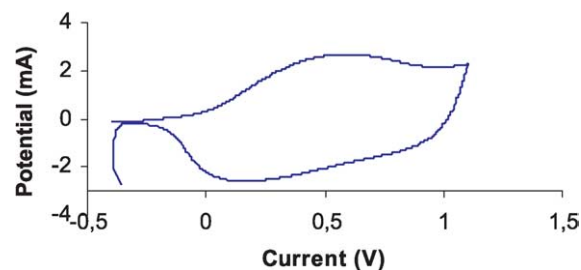


**Scheme 6.** The blockage of the radical cation redistribution in **3** and **7**.

polymerization to take place. The corresponding voltammogram is shown in Figure 2, which illustrates the electrodeposition of the polymer using dry acetonitrile as solvent. The formation of a new oxidation process around +0.7 V indicates the formation of the new polymer and its electroactivity on the working electrode. Figure 3 displays the voltammogram for the poly(**11**) in a monomer free solution. The polymer was completely dedoped before oxidation or reduction process to eliminate possible charge trapping during the experiment. Poly(**11**) exhibited one oxidation process at +0.60 V exemplifying that the polymer is a better electron donor than the monomer. The stability for the polymer to both different scans and even scan rate was not completely successful; therefore, we can say that the polymer derived from **11** is not as stable as expected. The absorption maxima for poly(**11**) was red-shifted by more than 100 nm confirming the increase in conjugation length (Table 2, Fig. 4) of the polymer in



**Figure 2.** Electrodeposition of **11** on Pt electrode in acetonitrile (Ag/AgCl as reference electrode, Pt as auxiliary electrode, 0.1 M LiClO<sub>4</sub> as supporting electrolyte, scan rate 50 mV/s).



**Figure 3.** Cyclic voltammogram of poly(**11**) in a monomer-free acetonitrile solution as a thin film on Pt working electrode (Ag/AgCl as reference electrode, Pt as auxiliary electrode, 0.1 M LiClO<sub>4</sub> as supporting electrolyte, scan rate 50 mV/s).

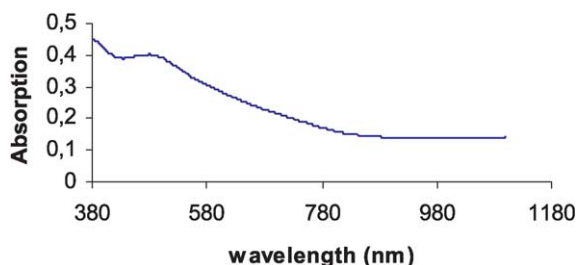


Figure 4. Electronic absorption spectra of poly(11) on ITO glass.

comparison with the monomer, which is typical for conducting polymers.<sup>12</sup> The optical band-gap of poly(11) can be obtained by UV/vis spectroscopy of ITO deposited films and is estimated from the longest wavelength absorption edge. The optical band-gap ( $E_g$ ) value for such a polymer is 1.5 eV, which is somehow lower than that corresponding to the polypyrrole (3.2 eV).<sup>13</sup> The difference between the onset potentials for the reduction and oxidation processes represents the electrochemical band-gap ( $E_g$ ), corresponding to the removal of electrons from the HOMO band and injection of electrons into the LUMO band. The electrochemical band-gap for poly(11) was 1.6 eV, which is in good agreement with the optical band-gap.

### 3. Conclusions

In conclusion, a novel approach to dipyrroles with diphenyleneoxide and diphenylenesulfide spacers based on the Trofimov reaction was developed. The prepared dipyrroles are promising for creating new conducting polymers with sulfur and oxygen atoms in the conjugation chain and for the study of the influence of the diphenylene-heteroatom moiety on conductivity of final polymer products. Poly(11) has been successfully prepared via electrochemical polymerization on Pt and ITO electrodes. Attempts to obtain the electrochemically generated polymers of 3 and 7 failed, which is due to unfavorable spin density distribution in the radical cations. The above dipyrroles possess the practically prospective luminescence properties, thus confirming the expectations.

## 4. Experimental

### 4.1. General

<sup>1</sup>H (400.13 MHz) and <sup>13</sup>C (101.61 MHz) NMR spectra were recorded on a Bruker DPX 400 spectrometer with HMDS as an internal standard. IR spectra were obtained on a Bruker IFS 25 instrument. Spectrophotometric and fluorimetric measurements were carried out on a UV/vis Lambda 25 instrument and the luminescence experimental setup.<sup>14</sup> Geometrical optimizations were performed with GAMESS code,<sup>15</sup> at the DFT-B3LYP level (Becke's three-parameter hybrid functional<sup>16</sup> where non-local correlation is provided by Lee, Yang, and Parr correlation functional<sup>17</sup> with the 6-311G\* basis set of Pople and co-workers.<sup>18</sup> In all calculations no symmetry constraints were applied ( $C_1$  symmetry point group was used throughout).

Commercial grade DMSO (Merck, <0.2% H<sub>2</sub>O), LiOH (<2% H<sub>2</sub>O), KOH (~15% H<sub>2</sub>O, in fact 2KOH·H<sub>2</sub>O) and 4,4'-diacetyldiphenyloxide dioxime 1 were used in experiments. For the preparation of 4,4'-diacetyldiphenylsulfide, see the Supplementary data.<sup>19</sup>

### 4.2. 4,4'-Bis(O-vinyloxime) of 4,4'-diacetyldiphenyloxide (2) and bis[2-(1-vinylpyrrolyl)]diphenyloxide (3)

**Method A.** A mixture of 1 (3.0 g, 10.6 mmol), KOH·0.5 H<sub>2</sub>O (1.37 g, 21.1 mmol) and DMSO (50 mL) was saturated with acetylene at room temperature (initial pressure 13 atm) and heated at 70 °C for 0.5 h whilst rotating. Thereupon, it was diluted with water up to 50 mL and extracted with ether (5 × 10 mL). The ether extracts were washed with water (3 × 10 mL), dried over K<sub>2</sub>CO<sub>3</sub>. The residue obtained after evaporation of the ether was chromatographed on Al<sub>2</sub>O<sub>3</sub> (hexane/ether 3:1) to give bis(O-vinyloxime) 2 (0.53 g, 15%).

**Method B.** The above mixture was saturated with acetylene and heated at 120 °C for 1 h whilst rotating. After the separation described bis(N-vinylpyrrolyl) 3 (1.0 g, 27%) was obtained.

**4.2.1. Compound 2.** White crystals, mp 32–34 °C. <sup>1</sup>H NMR (CDCl<sub>3</sub>) δ (ppm) 7.66 (d, 4H, H<sub>o</sub>, <sup>3</sup>J<sub>o-m</sub> = 8.8 Hz), 7.01 (m, 6H, H<sub>x</sub>, H<sub>m</sub>), 4.67 (dd, 2H, H<sub>B</sub>, <sup>3</sup>J<sub>BX</sub> = 14.3 Hz, <sup>2</sup>J<sub>AB</sub> = 1.2 Hz), 4.16 (dd, 2H, H<sub>A</sub>, <sup>3</sup>J<sub>AX</sub> = 7.8 Hz, <sup>2</sup>J<sub>AB</sub> = 1.2 Hz), 2.30 (s, 6H, Me). <sup>13</sup>C NMR (CDCl<sub>3</sub>) δ (ppm) 158.2 (C<sub>p</sub>), 156.6 (C=N), 152.8 (C<sub>α</sub>), 131.2 (C<sub>i</sub>), 128.2 (C<sub>o</sub>), 118.9 (C<sub>m</sub>), 88.2 (C<sub>β</sub>), 13.4 (Me). IR (cm<sup>-1</sup>, KBr): 3126, 3082, 3046, 3002, 2930, 2859, 1682, 1638, 1609, 1594, 1501, 1437, 1409, 1370, 1317, 1243, 1149, 1111, 1078, 1004, 970, 950, 885, 834, 761, 719, 699, 610, 593, 557, 493, 431. Anal. Calcd for C<sub>20</sub>H<sub>20</sub>N<sub>2</sub>O<sub>3</sub>: C, 71.41; H, 5.99; N, 8.33. Found: C, 71.44; H, 6.21; N, 8.63.

**4.2.2. Compound 3.** White crystals, mp 89–90 °C. <sup>1</sup>H NMR (CDCl<sub>3</sub>) δ (ppm) 7.34 (d, 4H, H<sub>o</sub>, <sup>3</sup>J<sub>o-m</sub> = 8.8 Hz), 7.09 (m, 2H, H<sub>5</sub>), 7.06 (d, 4H, H<sub>m</sub>, <sup>3</sup>J<sub>o-m</sub> = 8.8 Hz), 6.88 (dd, 2H, H<sub>x</sub>, <sup>3</sup>J<sub>BX</sub> = 15.8 Hz, <sup>3</sup>J<sub>AX</sub> = 8.9 Hz), 6.24 (m, 4H, H<sub>3</sub>, H<sub>4</sub>), 5.18 (dd, 2H, H<sub>B</sub>, <sup>3</sup>J<sub>BX</sub> = 15.8 Hz, <sup>2</sup>J<sub>AB</sub> = 1.2 Hz), 4.70 (dd, 2H, H<sub>A</sub>, <sup>3</sup>J<sub>AX</sub> = 8.9 Hz, <sup>2</sup>J<sub>AB</sub> = 1.2 Hz). <sup>13</sup>C NMR (CDCl<sub>3</sub>) δ (ppm) 156.5 (C<sub>p</sub>), 133.7 (C<sub>2</sub>), 132.0 (C<sub>α</sub>), 130.9 (C<sub>m</sub>), 127.8 (C<sub>i</sub>), 118.9 (C<sub>o</sub>), 118.2 (C<sub>5</sub>), 110.1, 109.9 (C<sub>3</sub>, C<sub>4</sub>), 98.9 (C<sub>β</sub>). IR (cm<sup>-1</sup>, KBr): 3140, 3095, 3051, 3004, 1643, 1609, 1598, 1573, 1546, 1496, 1467, 1425, 1348, 1312, 1279, 1232, 1179, 1168, 1100, 1075, 1030, 1013, 974, 950, 871, 860, 837, 819, 802, 786, 737, 717, 696, 668, 594, 569, 510. Anal. Calcd for C<sub>24</sub>H<sub>20</sub>N<sub>2</sub>O: C, 81.79; H, 5.72; N, 7.95. Found: C, 81.41; H, 5.89; N, 7.69.

### 4.3. 4,4'-Diacetyldiphenylsulfide dioxime (4)

A mixture of 4,4'-diacetyldiphenylsulfide (3.9 g, 14.4 mmol), NH<sub>2</sub>OH·HCl (2.9 g, 41.7 mmol) and pyridine (30 mL) was stirred for 6 h at 80 °C, thereupon, it was cooled and poured into cold water (150 mL). The precipitate was filtered, washed with water and dried to afford dioxime 4 (4.3 g, 99%).

**4.3.1. Compound 4.** White powder, mp 188–190 °C. <sup>1</sup>H

NMR (DMSO- $d_6$ )  $\delta$  (ppm) 10.00 (s, 2H, OH), 7.65 (d, 4H,  $H_o$ ,  $^3J_{o-m}=7.7$  Hz), 7.33 (d, 4H,  $H_m$ ,  $^3J_{o-m}=7.7$  Hz), 2.13 (s, 6H, Me).  $^{13}\text{C}$  NMR (DMSO- $d_6$ )  $\delta$  (ppm) 152.3 (C=N), 136.1, 135.0 ( $C_i$ ,  $C_p$ ), 130.6, 126.7 ( $C_o$ ,  $C_m$ ), 11.4 (Me). IR ( $\text{cm}^{-1}$ , KBr): 3307, 3242, 3091–2927, 1648, 1589, 1551, 1491, 1440, 1393, 1370, 1315, 1270, 1187, 1128, 1112, 1030, 1097, 1072, 1019, 1008, 934, 825, 785, 751, 716, 703, 567, 557, 515, 501, 487, 449, 434. Anal. Calcd for  $\text{C}_{16}\text{H}_{16}\text{N}_2\text{O}_2\text{S}$  (%): C, 63.98; H, 5.37; N, 9.33; S, 10.67. Found (%): C, 63.83; H, 5.47; N, 9.27; S, 11.20.

#### 4.4. 4,4'-Bis(2-pyrrolyl)diphenylsulfide (5), 4-(2-pyrrolyl)-4'-[2-(1-vinylpyrrolyl)]diphenylsulfide (6) and 4,4'-bis[2-(1-vinylpyrrolyl)]diphenylsulfide (7)

**Method A.** A mixture of dioxime **4** (2.00 g, 6.7 mmol), LiOH (0.32 g, 13.3 mmol) and DMSO (75 mL) was saturated with acetylene at room temperature (initial pressure 10 atm) and heated at 130 °C for 3 h whilst rotating. Thereupon, it was diluted with water up to 150 mL and extracted with ether (5  $\times$  30 mL). The ether extracts were washed with water (3  $\times$  30 mL), dried over  $\text{K}_2\text{CO}_3$  and evaporated to afford deep-brown residue (1.51 g), which was then extracted with a hexane/ether mixture 1:1. Insoluble part was filtered out, washed out with the same mixture of solvents and dried to afford dipyrrole **5** (0.16 g, 8%). The soluble part was chromatographed on  $\text{Al}_2\text{O}_3$  (hexane/ether 3:1) to give monovinylidipyrrole **6** (0.29 g, 13%) and divinylpyrrole **7** (0.14 g, 6%).

**Method B.** A mixture of **4** (0.60 g, 2 mmol),  $\text{KOH}\cdot 0.5 \text{H}_2\text{O}$  (0.26 g, 4 mmol) and DMSO (20 mL) was saturated with acetylene at room temperature (initial pressure 15 atm) and heated at 110 °C for 1 h whilst rotating. Thereupon, it was diluted with water up to 50 mL and extracted with ether (5  $\times$  10 mL). The ether extracts were washed with water (3  $\times$  10 mL) and dried over  $\text{K}_2\text{CO}_3$ . The residue obtained after evaporation of the ether was chromatographed on  $\text{Al}_2\text{O}_3$  (hexane/ether 3:1) to give divinylidipyrrole **7** (0.10 g, 14%).

**4.4.1. Compound 5.** Light-brown crystals, mp 123–126 °C.  $^1\text{H}$  NMR (DMSO- $d_6$ )  $\delta$  (ppm) 11.36 (broad s, 2H, NH), 7.61 (d, 4H,  $H_o$ ,  $^3J_{o-m}=8.5$  Hz), 7.30 (d, 4H,  $^3J_{o-m}=8.5$  Hz), 6.86 (m, 2H,  $H_5$ ), 6.53 (m), 6.11 (m, 4H,  $H_3$ ,  $H_4$ ).  $^{13}\text{C}$  NMR (DMSO- $d_6$ )  $\delta$  (ppm) 132.6, 131.7, 130.7 ( $C_i$ ,  $C_p$ ,  $C_2$ ), 131.6, 124.7 ( $C_o$ ,  $C_m$ ), 120.2 ( $C_5$ ), 109.7, 106.6 ( $C_3$ ,  $C_4$ ). IR ( $\text{cm}^{-1}$ , KBr): 3438, 3391, 1668, 1638, 1596, 1491, 1452, 1426, 1297, 1243, 1189, 1114, 1032, 915, 880, 826, 799, 723, 543. Anal. Calcd for  $\text{C}_{20}\text{H}_{16}\text{N}_2\text{S}$ : C, 75.92; H, 5.10; N, 8.85; S, 10.13. Found: C, 76.22; H, 5.00; N, 9.20; S, 9.94.

**4.4.2. Compound 6.** Beige crystals, mp 112–115 °C.  $^1\text{H}$  NMR (DMSO- $d_6$ )  $\delta$  (ppm) 10.45 (broad s, 1H, NH), 7.57 (m, 2H,  $H_m$ ), 7.42 (m, 2H,  $H_o$ ), 7.27 (s, 4H,  $H_o$ ,  $H_m$ ), 7.10 (m, 1H,  $H_5$ ), 6.85 (dd, 1H,  $H_X$ ,  $^3J_{\text{BX}}=15.6$  Hz,  $^3J_{\text{AX}}=8.8$  Hz), 6.83 (m, 1H,  $H_5$ ), 6.51 (m, 1H,  $H_3$ ), 6.24 (m, 3H,  $H_3$ ,  $H_4$ ,  $H_4'$ ), 5.19 (dd, 1H,  $H_B$ ,  $^3J_{\text{BX}}=15.6$  Hz,  $^2J_{\text{AB}}=1.0$  Hz), 4.72 (dd, 1H,  $H_A$ ,  $^3J_{\text{AX}}=8.8$  Hz,  $^2J_{\text{AB}}=1.0$  Hz).  $^{13}\text{C}$  NMR (DMSO- $d_6$ )  $\delta$  (ppm) 135.8 ( $C_i$ ), 133.1 ( $C_2'$ ), 132.5 ( $C_m$ ,  $C_i$ ), 131.5 ( $C_o$ ), 130.8 ( $C_2$ ), 130.3 ( $C_p$ ), 130.1 ( $C_p'$ ), 129.3, 129.1 ( $C_o'$ ,  $C_m'$ ), 124.3 ( $C_o$ ), 119.3 ( $C_5$ ), 118.3 ( $C_5'$ ), 107.4 ( $C_3'$ ,  $C_4'$ ), 109.3 ( $C_4$ ), 105.9 ( $C_5$ ), 98.9 ( $C_B$ ). IR ( $\text{cm}^{-1}$ , KBr): 3434, 3143, 3102, 3055, 1675, 1642, 1595,

1565, 1516, 1491, 1461, 1424, 1348, 1316, 1297, 1266, 1240, 1195, 1180, 1123, 1086, 1075, 1032, 1014, 973, 949, 916, 875, 835, 821, 798, 716, 675, 593, 573, 538. Anal. Calcd for  $\text{C}_{22}\text{H}_{18}\text{N}_2\text{S}$ : C, 77.16; H, 5.30; N, 8.18; S, 9.36. Found: C, 77.35; H, 5.41; N, 8.19; S, 8.97.

**4.4.3. Compound 7.** Beige crystals, mp 102–106 °C.  $^1\text{H}$  NMR ( $\text{CDCl}_3$ )  $\delta$  (ppm) 7.34 (d, 4H,  $H_o$ ,  $^3J_{o-m}=8.5$  Hz), 7.27 (d, 4H,  $H_m$ ,  $^3J_{o-m}=8.5$  Hz), 7.11 (dd, 2H,  $H_5$ ,  $^3J_{4-5}=2.7$  Hz,  $^4J_{3-5}=1.7$  Hz), 6.84 (dd, 2H,  $H_X$ ,  $^3J_{\text{BX}}=15.7$  Hz,  $^3J_{\text{AX}}=8.7$  Hz), 6.24 (m, 4H,  $H_3$ ,  $H_4$ ), 5.18 (dd, 2H,  $H_B$ ,  $^3J_{\text{BX}}=15.7$  Hz,  $^2J_{\text{AB}}=1.2$  Hz), 4.70 (dd, 2H,  $H_A$ ,  $^3J_{\text{AX}}=8.7$  Hz,  $^2J_{\text{AB}}=1.2$  Hz).  $^{13}\text{C}$  NMR ( $\text{CDCl}_3$ )  $\delta$  (ppm) 134.4, 133.3, 131.3 ( $C_i$ ,  $C_p$ ,  $C_2$ ), 131.8 ( $C_o$ ), 130.9, 129.7 ( $C_o$ ,  $C_m$ ), 118.8 ( $C_5$ ), 110.4, 110.3 ( $C_3$ ,  $C_4$ ), 99.2 ( $C_B$ ). IR ( $\text{cm}^{-1}$ , KBr): 3133, 3106, 3075, 3026, 3002, 2929 (=CH), 1641, 1594, 1552, 1489, 1462, 1415, 1349, 1316, 1290, 1238, 1181, 1107, 1085, 1074, 1013, 974, 950, 880, 869, 829, 796, 729, 714, 674, 595, 574, 533, 517, 493. Anal. Calcd for  $\text{C}_{24}\text{H}_{20}\text{N}_2\text{S}$  (%): C, 78.23; H, 5.47; N, 7.60; S, 8.70. Found (%): C, 78.18; H, 5.62; N, 7.25; S, 8.71.

#### 4.5. 4,4'-Bis(vinylximinoethyl)diphenylsulfide (8) and 4-(1-vinylximinoethyl)-4'-(2-pyrrolyl)diphenylsulfide (9)

A mixture of **4** (0.60 g, 2 mmol),  $\text{KOH}\cdot 0.5 \text{H}_2\text{O}$  (0.26 g, 4 mmol) and DMSO (20 mL) was saturated with acetylene at room temperature (initial pressure 12 atm) and heated at 90 °C for 5 min whilst rotating. Thereupon, it was diluted with water up to 50 mL and extracted with ether (5  $\times$  10 mL). The ether extracts were washed with water (3  $\times$  10 mL), dried over  $\text{K}_2\text{CO}_3$ . The residue obtained after evaporation of the ether was chromatographed on  $\text{Al}_2\text{O}_3$  (hexane/ether 3:1) to give bis(*O*-vinyl)dioxime **8** (0.085 g, 12%), monopyrrole derivative **9** (0.040 g, 6%) and dipyrrole **5** (0.045 g, 7%).

**4.5.1. Compound 8.** White crystals, mp 60–62 °C.  $^1\text{H}$  NMR ( $\text{CDCl}_3$ )  $\delta$  (ppm) 7.61 (d, 4H,  $H_o$ ,  $^3J_{o-m}=8.1$  Hz), 7.33 (d, 4H,  $H_m$ ,  $^3J_{o-m}=8.1$  Hz), 7.02 (dd, 2H,  $H_X$ ,  $^3J_{\text{BX}}=14.3$  Hz,  $^3J_{\text{AX}}=7.8$  Hz), 4.68 (dd, 2H,  $H_B$ ,  $^3J_{\text{BX}}=14.3$  Hz,  $^2J_{\text{AB}}=1.2$  Hz), 4.18 (dd, 2H,  $H_A$ ,  $^3J_{\text{AX}}=7.8$  Hz,  $^2J_{\text{AB}}=1.2$  Hz), 2.29 (s, 6H, Me).  $^{13}\text{C}$  NMR ( $\text{CDCl}_3$ )  $\delta$  (ppm) 156.5 (C=N), 152.8 ( $C_o$ ), 137.3, 134.6 ( $C_i$ ,  $C_p$ ), 130.9, 127.2 ( $C_o$ ,  $C_m$ ), 88.4 ( $C_B$ ), 13.2 (Me). IR ( $\text{cm}^{-1}$ , KBr): 3122, 3075, 2923, 2857, 1673, 1641, 1607, 1489, 1458, 1391, 1371, 1317, 1270, 1170, 1128, 1110, 1094, 1071, 1004, 972, 945, 887, 837, 783, 727, 714, 680, 573, 556, 507, 475, 426, 411. Anal. Calcd for  $\text{C}_{20}\text{H}_{20}\text{N}_2\text{O}_2\text{S}$ : C, 68.16; H, 5.72; N, 7.95; S, 9.10. Found: C 68.33, H, 5.65; N, 7.71; S, 8.57.

**4.5.2. Compound 9.** Cream crystals, mp 138–142 °C.  $^1\text{H}$  NMR ( $\text{CDCl}_3$ )  $\delta$  (ppm) 8.45 (br s, 1H, NH), 7.59 (d), 7.43 (d), 7.37 (d), 7.24 (d, 8H,  $H_o$ ,  $H_m$ ,  $H_o'$ ,  $H_m'$ ,  $^3J_{o-m}=8.5$  Hz,  $^3J_{o-m'}=4.5$  Hz), 7.02 (dd, 1H,  $H_X$ ,  $^3J_{\text{BX}}=14.2$  Hz,  $^3J_{\text{AX}}=7.8$  Hz), 6.87 (m, 2H,  $H_5$ ), 6.54 (m), 6.30 (m, 4H,  $H_3$ ,  $H_4$ ), 4.68 (dd, 1H,  $H_B$ ,  $^3J_{\text{BX}}=14.2$  Hz,  $^2J_{\text{AB}}=1.2$  Hz), 4.17 (dd, 1H,  $H_A$ ,  $^3J_{\text{AX}}=7.8$  Hz,  $^2J_{\text{AB}}=1.2$  Hz), 2.27 (s, 3H, Me).  $^{13}\text{C}$  NMR ( $\text{CDCl}_3$ )  $\delta$  (ppm) 156.7 (C=N), 152.8 ( $C_o$ ), 139.4, 133.8, 133.3, 132.5, 131.3, 131.2, 129.2, 127.0, 124.6 ( $C_i$ ,  $C_i'$ ,  $C_o$ ,  $C_o'$ ,  $C_m$ ,  $C_m'$ ,  $C_p$ ,  $C_p'$ ,  $C_2$ ), 119.5 ( $C_5$ ), 110.5, 106.8 ( $C_3$ ,  $C_4$ ), 88.3 ( $C_B$ ), 13.2 (Me). IR ( $\text{cm}^{-1}$ , KBr): 3435, 3137,



3106, 3072, 2932, 2857, 1637, 1603, 1558, 1506, 1490, 1454, 1430, 1416, 1397, 1367, 1318, 1172, 1130, 1099, 1067, 1036, 1006, 975, 952, 917, 886, 838, 821, 799, 730, 668, 549, 477, 411. Anal. Calcd for C<sub>20</sub>H<sub>18</sub>N<sub>2</sub>OS: C, 71.83; H, 5.42; N, 8.38; S, 9.59. Found: C, 71.69; H, 5.23; N, 8.51; S, 9.69.

### Acknowledgements

This work was supported by the Russian Foundation for Basic Research (grants no. 03-03-32472 and no. 2241.2003.3) and the Presidium of the Russian Academy of Sciences (grant no. 10002-251/P-25/155-305/200404-072).

### Supplementary data

Supplementary data associated with this article can be found, in the online version, at [doi:10.1016/j.tet.2005.05.088](https://doi.org/10.1016/j.tet.2005.05.088).

### References and notes

- Soloducho, J. *Synth. Met.* **1999**, *99*, 181–189.
- Eldo, J.; Arunkumar, E.; Ajayaghosh, A. *Tetrahedron Lett.* **2000**, *41*, 6241–6244.
- Soloducho, J.; Doskocz, J.; Cabaj, J.; Roszak, S. *Tetrahedron* **2003**, *59*, 4761–4766.
- Aldakov, D.; Anzenbacher, P., Jr. *Chem. Commun.* **2003**, 1394–1395.
- Handbook of Conducting Polymers*; Skotheim, T. A., Elsenbaumer, R. L., Reynolds, J. R., Eds.; Marcel Dekker: New York/Basel/Hong Kong, 1998.
- Zhu, K.; Wang, L.; Jing, X.; Wang, F. *J. Mater. Chem.* **2002**, *12*, 181–187.
- (a) Trofimov, B. A. Preparation of Pyrroles from Ketoximes and Acetylenes. In *Advances in Heterocyclic Chemistry*; Kartritzky, A. R., Ed.; Academic: San Diego, 1990; Vol. 51, pp 177–301. (b) Bean, G. P. The Synthesis of 1H-Pyrroles. Part 1. Pyrroles. In *The Synthesis and the Chemical and the Physical Aspects Pyrrole Ring*; Jones, R. A., Ed.; Wiley: New York, 1992; p 105. (c) Trofimov, B. A. Vinylpyrroles In *The Chemistry of Heterocyclic Compounds. Part 2*; Jones, R. A., Ed.; Wiley: New York, 1992; Vol. 48, pp 131–298. (d) Tedeschi, R. J. Acetylene; In *Encyclopedia of Physical Science and Technology*; Academic: San Diego, 1992; Vol. 1; pp 27–65 (e) Gossauer, A. Pyrrole; In Georg Thieme: Stuttgart, 1994; *Methoden Der Organischen Chemie. Heterarene I. Teil 1*; pp 556–798. (f) Mikhaleva, A. I.; Schmidt, E. Yu. Two-step Synthesis of Pyrroles from Ketones and Acetylenes through the Trofimov Reaction. In *Selected Methods for Synthesis and Modification of Heterocycles*; Kartsev, V. G., Ed.; IBS: Moscow, 2002; Vol. 1, 331–352.
- Korostova, S. E.; Mikhaleva, A. I. *Zh. Org. Khim.* **1982**, *18*, 2620–2621.
- Trofimov, B. A.; Mikhaleva, A. I. N-Vinylpyrroles; Nauka: Novosibirsk, 1984; p 264, in Russian.
- Schmidt, E. Yu.; Zorina, N. V.; Zaitsev, A. B.; Mikhaleva, A. I.; Vasil'tsov, A. M.; Audebert, P.; Clavier, G.; Méallet-Renault, R.; Pansu, R. B. *Tetrahedron Lett.* **2004**, *45*, 5489–5491.
- Hlavatý, J.; Papež, V.; Kavan, L.; Krtíl, P. *Synth. Met.* **1994**, *66*, 165–168.
- Chapman, G. M.; Stanforth, S. P.; Berridge, R.; Pozo-Gonzalo, C.; Skabara, P. J. *J. Mater. Chem.* **2002**, *12*, 2292–2298.
- Abdou, M. S. A.; Holdcroft, S. In *Handbook of Organic Conductive Molecules and Polymers*; Nawa, H. S., Ed.; Wiley: New York, 1997; p 613.
- Petrushenko, K. B.; Klyba, L. V.; Smirnov, V. I.; Shevchenko, S. G. *Russ. Chem. Bull.* **2001**, *50*, 798–804.
- Schmidt, M. W.; Baldrige, K. K.; Boatz, J. A.; Elbert, S. T.; Gordon, M. S.; Jensen, J. H.; Koseki, S.; Matsunaga, N.; Nguyen, K. A.; Su, S. J.; Windus, T. L.; Dupuis, M.; Montgomery, J. A. *J. Comp. Chem.* **1993**, *14*, 1347–1363.
- Becke, A. D. *J. Chem. Phys.* **1993**, *98*, 5648–5652.
- Lee, C.; Yang, W.; Parr, R. G. *Phys. Rev. B* **1988**, *37*, 785–789.
- Krisnan, R.; Binkley, J. S.; Seeger, R.; Pople, J. A. *J. Chem. Phys.* **1980**, *72*, 650–654.
- Supplementary Material is available on the Elsevier site <http://www.elsevier.com>.

# Calculated NMR as a tool for structural elucidation of jungianol and mutisianthol

Gil V. J. da Silva\* and Álvaro Cunha Neto

*Departamento de Química, Faculdade de Filosofia, Ciências e Letras de Ribeirão Preto, Universidade de São Paulo, Avenida Bandeirantes, 3900, 14040-901 Ribeirão Preto, SP, Brazil*

Received 21 February 2005; revised 25 May 2005; accepted 26 May 2005

Available online 17 June 2005

**Abstract**—Theoretical methods were used for the correct structure assignments of the natural products jungianol and mutisianthol. A three stage protocol for the calculation was used: a conformational search using molecular mechanics (MM3), a DFT (B3LYP) structure optimization and ab initio (HF/GIAO) or DFT (B3LYP/GIAO) calculation of magnetic properties.

© 2005 Elsevier Ltd. All rights reserved.

## 1. Introduction

Nuclear magnetic resonance is one of the most powerful techniques for structural elucidation of organic compounds. It is indispensable in the characterization of complex natural products presenting several diastereoisomers, which can be unequivocally distinguished by their NMR spectra, either through direct comparison of chemical shifts and coupling constants, or by means of special techniques such as nuclear Overhauser enhancement or correlation spectroscopy.

The major pitfall in the structural elucidation of a new natural product is that usually only one of a set of possible diastereoisomers is isolated. Sometimes, this kind of difficulty leads even experienced and skilful researchers to make mistakes, reporting erroneous structures for newly isolated compounds.

The traditional approach for the confirmation of the structure of a natural product is through the stereoselective synthesis. In spite of this being the safest and definite approach, the process is time consuming and frequently requires the development of new synthetic methodology. As a matter of fact, it is not unusual that the synthesis lags isolation of a new natural product for many years.

Bohlman et al. reported in 1977 the isolation and characterization of a new phenolic sesquiterpene, jungianol,<sup>1</sup> from the South American plant *Jungia*

*malvaefolia*. Later, in 1979, the same group reported the isolation of a related compound from *Mutisia homoeantha*, which was named mutisianthol.<sup>2</sup> Based on <sup>1</sup>H NMR spectra, these compounds were assigned the structures **1** and **2**, respectively (Fig. 1). Those assignments remained undisputed in the literature for about 20 years, when finally, Ho et al. tried to synthesize mutisianthol.<sup>3</sup> Once they prepared the acetylated *cis*-indane **3**, a mismatch was found between the <sup>1</sup>H NMR spectrum of this compound and Bohlman's published data for mutisianthol. Ho et al., then, modified their synthetic route and prepared the *trans* diastereoisomer **5**, which showed spectroscopic data identical to natural mutisianthol.

Recently, Hashmi et al., applied a gold-catalyzed phenol synthesis to prepare jungianol and its diastereoisomer.<sup>4</sup> Comparison of the <sup>1</sup>H NMR spectra and Bohlman's data showed the diastereoisomer obtained as the minor synthetic product was identical to the natural product, that is, jungianol, and the major one was then *epi*-jungianol. A detailed analysis by NMR spectroscopy and an X-ray crystallography study of a derivative of *epi*-jungianol demonstrated that the naturally occurring jungianol was the *trans* diastereoisomer **4**.

Theoretical calculation of chemical shift has been under development for over three decades,<sup>5</sup> and has achieved a high degree of agreement to experimental data. To solve a common difficulty in the calculation of magnetic properties, the gauge origin problem,<sup>5</sup> several methods were developed; the most used of them is the gauge-including atomic orbital (GIAO) method.<sup>6–9</sup>

In this study, we use the GIAO method to calculate chemical

**Keywords:** Chemical shift calculation; Structural elucidation; NMR; GIAO; Sesquiterpene.

\* Corresponding author. Tel.: +55 16 6023699; fax: +55 16 633 8151; e-mail: [gvjdsilv@usp.br](mailto:gvjdsilv@usp.br)

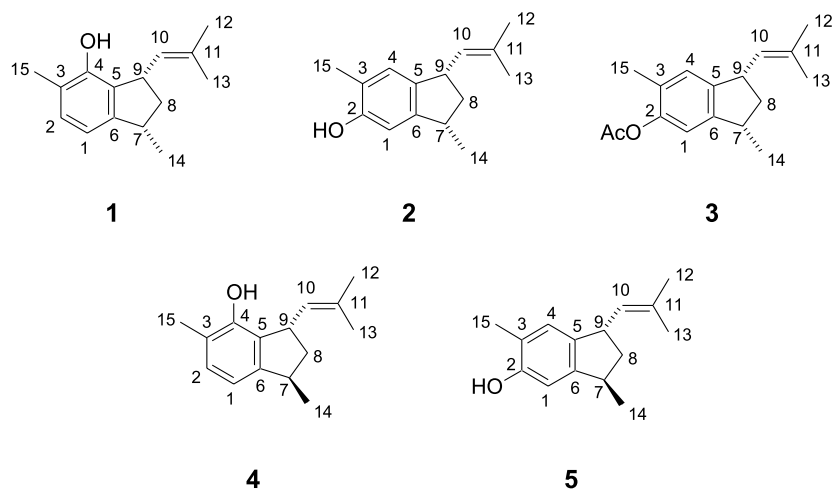


Figure 1. Some phenolic sesquiterpenes.

shifts for the *cis* and *trans* isomers of jungianol and mutisianthol as a valuable aid to the correct assignment of the structures of the natural products.

## 2. Methods

In order to compare calculated and experimental NMR data, one has to know the conformational preferences of the

molecule. Conformational search algorithms were developed for the generation of many different conformers for a given structure, and then, after energy minimization, ordering them with respect to their relative energy. Several methods are available for conformational search:<sup>10,11</sup> Monte Carlo,<sup>12,13</sup> low mode,<sup>14</sup> molecular dynamics,<sup>15</sup> simulated annealing,<sup>16</sup> distance geometry,<sup>17</sup> genetic algorithms,<sup>18</sup> etc.

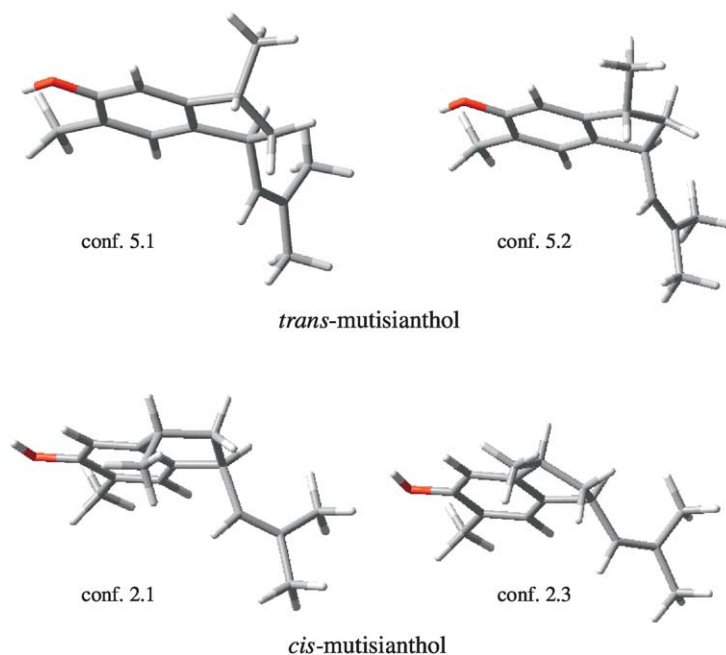
For small molecules, as is the case in our study, Monte Carlo

Table 1. Low energy conformers found for structures 1, 2, 4 and 5

Structure	Conformer	Rel. energy (kJ/mol) MM3 <sup>a</sup>	Rel. energy (kJ/mol) B3LYP/6-31G(d) <sup>b</sup>		Boltzmann population (%)	
			Vapour	Chloroform	Vapour	Chloroform
1	1.1	0.00	3.18	4.52	21.92	14.35
	1.2	0.46	0.00	0.00	77.54	85.48
	1.3	3.43	14.43	18.03	0.25	0.07
	1.4	4.44	14.43	18.54	0.25	0.06
	1.5	5.82	20.08	19.08	0.03	0.04
	1.6	10.04	22.89	24.18	0.01	0.01
	1.7	13.35	31.97	35.61	—	—
	1.8	17.20	38.95	44.73	—	—
2	2.1	0.00	0.00	0.00	65.99	89.74
	2.2	1.00	8.74	10.13	2.05	1.6
	2.3	3.39	1.92	6.02	30.49	8.22
	2.4	4.44	10.71	14.98	0.88	0.24
	2.5	5.23	12.89	15.77	0.4	0.17
	2.6	8.62	14.81	20.63	0.18	0.02
	2.7	14.73	25.52	28.95	—	—
	2.8	18.20	27.66	34.14	—	—
4	4.1	0.00	6.11	5.56	7.92	9.66
	4.2	4.10	0.00	0.00	89.39	88.29
	4.3	5.61	13.01	13.35	0.52	0.44
	4.4	10.00	16.78	14.18	0.11	0.32
	4.5	10.71	11.25	11.72	1.03	0.85
	4.6	12.89	28.58	28.66	—	—
	4.7	15.69	11.25	13.35	1.03	0.45
	4.8	17.99	29.25	29.25	—	—
5	5.1	0.00	2.51	6.07	18.24	5.77
	5.2	1.59	0.00	0.00	49.71	63.72
	5.3	3.35	4.60	8.16	8.06	2.51
	5.4	4.90	1.88	2.09	23.45	27.71
	5.5	7.11	12.59	14.14	0.33	0.23
	5.6	10.38	14.52	19.62	0.16	0.03
	5.7	14.14	18.16	20.08	0.04	0.02

<sup>a</sup> MCMM and Newton–Raphson optimization using MacroModel 7.2.<sup>10</sup>

<sup>b</sup> Geometry optimization and frequency calculation (ZPE) using Gaussian 98.<sup>12</sup>



**Figure 2.** Low energy conformers of *cis*- and *trans*-mutisianthol showing the flip-flop movement of the methylene group in the five-membered ring. (Pictures generated by GaussView).<sup>28</sup>

method is very efficient because it searches the entire conformational space of the molecule, finding conformers that are close in energy and differ in shape.<sup>11</sup>

Our study starts with a throughout conformational search, in gas phase, using the MM3 force field,<sup>19</sup> implemented in Macromodel 7.2 program.<sup>20</sup> Initially, a 5000 steps Monte Carlo multiple minimum (MCM) search followed by a Newton–Raphson minimization was run.<sup>21</sup> The most stable conformers (within a range of 20 kJ/mol) obtained were submitted to a second Newton–Raphson minimization (1000 steps), resulting in eight conformers for each structure (**1**, **2**, **4** and **5**).

The conformers in the output file obtained in the conformational search, as describe above, were further optimized using density functional theory (DFT) at the B3LYP level of theory and 6-31G(d) basis set,<sup>22</sup> as implemented in the program Gaussian 98.<sup>23</sup> The calculations were performed both in vacuo and in solvent (chloroform) using Tomasi's Polarized Continuum Model.<sup>24</sup> Single-point calculations were carried out at the same level of theory to characterize minima as such, from frequency analyses, and for zero point energy (ZPE) and thermal corrections. The set of conformers corresponding to >98% of the Boltzmann population in chloroform, was selected for isotropic magnetic shielding (IMS) calculation using the GIAO method at the HF level of theory and the basis set 6-311 + G(2d,p),<sup>25</sup> as recommended by Cheeseman et al.<sup>26</sup> Other basis set used was cc-pVDZ,<sup>27</sup> either at HF and B3LYP level of theory. The calculated chemical shift is the difference between the IMS for the conformer and the IMS of <sup>1</sup>H and <sup>13</sup>C in TMS, calculated by the same method. The weighted average, considering the Boltzmann population of the conformers, allowed the calculation of <sup>1</sup>H and <sup>13</sup>C chemical shifts of the compounds. The scaled chemical

shifts were obtained by linear fit of the calculated versus the experimental chemical shifts.<sup>9</sup>

### 3. Results and discussion

The proposed structures for jungianol (**1**) and mutisianthol (**2**) and their *trans* isomers (**4** and **5**, respectively), were analyzed according to the protocol described above. Table 1 shows the calculated energies and conformer composition for a sample of each compound. Inspection of the lower energy conformers of these molecules reveals that the main conformational change is a flip-flop movement of the methylene group in the five-membered ring (Fig. 2).

IMS calculations were performed at different theory levels. Hartree–Fock method using Pople's basis set type [6-311 + G(2d,p)], gave a good correlation between calculated and experimental chemical shifts. Some improvement was observed when using Dunning's basis set type (cc-pVDZ), resulting in a standard deviation of approximately 0.21 for **4** and **5**, and a shorter computation time. The best results were obtained when using a DFT method (B3LYP) and the cc-pVDZ basis set for the IMS calculation, giving a standard deviation as low as 0.10 and 0.12 for **4** and **5**, respectively.

Table 2 shows the comparison of <sup>1</sup>H chemical shifts for natural jungianol and the weighted average, considering the Boltzmann population of each conformer, of the calculated <sup>1</sup>H chemical shifts for structures **1** and **4** at B3LYP/cc-pVDZ. The table also presents the absolute error, the mean absolute error and the standard deviation of scaled chemical shifts compared to the experimental results. Similarly, Table 3 compares data for natural mutisianthol and structures **2** and **5**. In both cases, the mean absolute error and the total standard deviation show a better fit between the experimental values and those calculated for the *trans*

**Table 2.** Comparison of experimental  $^1\text{H}$  chemical shifts for jungianol and calculated data (B3LYP/cc-pVDZ) for structures **1** and **4**

Atoms	<b>1</b>				<b>4</b>		
	$\delta_{\text{exp}}^{\text{a}}$	$\delta_{\text{calcd}}^{\text{b}}$	$\delta_{\text{scaled}}^{\text{c}}$	$\varepsilon^{\text{d}}$	$\delta_{\text{calcd}}^{\text{b}}$	$\delta_{\text{scaled}}^{\text{c}}$	$\varepsilon^{\text{d}}$
1-H	6.68	6.56	6.52	0.16	6.51	6.58	0.10
2-H	6.97	7.15	7.12	0.15	6.88	6.95	0.02
7-H	3.25	3.12	3.02	0.23	3.10	3.19	0.06
8a-H	1.98	1.39	1.26	0.72	1.84	1.94	0.04
8b-H	1.98	2.37	2.26	0.28	1.71	1.81	0.17
9-H	4.18	4.08	4.00	0.18	4.14	4.23	0.05
10-H	5.31	5.61	5.56	0.25	5.40	5.48	0.17
12-H	1.80	2.11	1.99	0.19	1.84	1.94	0.14
13-H	1.87	2.06	1.94	0.07	1.78	1.88	0.01
14-H	1.20	1.54	1.41	0.21	1.13	1.23	0.03
15-H	2.19	2.44	2.32	0.13	2.08	2.18	0.01
				0.24 <sup>e</sup>			0.07 <sup>e</sup>
				0.31 <sup>f</sup>			0.10 <sup>f</sup>

<sup>a</sup> Data from Ref. 1.<sup>b</sup> Weighted average from the calculated shift for the most stable conformers.<sup>c</sup> Obtained by linear fit of  $\delta_{\text{calcd}}$  versus  $\delta_{\text{exp}}$ .<sup>9</sup><sup>d</sup>  $\varepsilon = |\delta_{\text{exp}} - \delta_{\text{scaled}}|$ .<sup>e</sup> Mean absolute error:  $\Sigma\varepsilon/n$ , where  $n=11$  (number of compared chemical shifts).<sup>f</sup> Standard deviation from the linear fit.

isomers. In spite of the rigidity of the ring system and the small effect of the configuration change on the overall spectra, it is reasonable to expect some unique feature linking a compound to a particular spectrum. In this study, such a subtlety could be found in the calculated spectra for each *cis/trans* pair of compounds, **1/4** and **2/5**: the chemical shifts of  $\text{H}_{8\text{a}}$  and  $\text{H}_{8\text{b}}$  are about the same for the *trans* isomers but have a big difference ( $\Delta\delta \sim 1$  ppm) for the *cis* isomers, as previously noted by Hashmi et al.<sup>4</sup> According to Bohlman's data,<sup>1,2</sup> those protons are isochronous and have  $\delta = 1.98$  in jungianol and  $\delta = 1.93$  in mutisianthol. This data present an excellent agreement to the calculated (scaled) data for the *trans* isomers **4** and **5**, respectively. The subtle effect found in the chemical shifts of  $\text{H}_{8\text{a}}$  and  $\text{H}_{8\text{b}}$  was observed irrespective to the theoretical method used.

The calculated  $^{13}\text{C}$  chemical shifts for structure **5** (*trans*), using HF/6-311+G(2d,p) or HF/cc-pVDZ or B3LYP/cc-pVDZ, show a better correlation to the published experimental data for mutisianthol than the calculated

values for structure **2** (*cis*) do (Table 4). Although this result is in agreement with that for  $^1\text{H}$ , the calculated chemical shifts for both isomers are too close to allow a clear-cut assignment. Concerning the  $^{13}\text{C}$  chemical shifts of the natural jungianol and those calculated for structures **1** and **4**, no comparison was made, since as far as we know, the  $^{13}\text{C}$  chemical shifts for the natural product were not published.

#### 4. Conclusion

The study of the conformational preferences and calculation of chemical shifts by ab initio and DFT methods is a convenient aid in the structure elucidation of natural products. Initially, a good correlation between calculated and experimental data is a good criterion for the correct assignment of the structure; moreover, the calculation can reveal subtle differences in the NMR spectra of isomers that can reinforce the characterization.

**Table 3.** Comparison of experimental  $^1\text{H}$  chemical shifts for mutisianthol and calculated data (B3LYP/cc-pVDZ) for structures **2** and **5**

Atoms	<b>2</b>				<b>5</b>		
	$\delta_{\text{exp}}^{\text{a}}$	$\delta_{\text{calcd}}^{\text{b}}$	$\delta_{\text{scaled}}^{\text{c}}$	$\varepsilon^{\text{d}}$	$\delta_{\text{calcd}}^{\text{b}}$	$\delta_{\text{scaled}}^{\text{c}}$	$\varepsilon^{\text{d}}$
1-H	6.61	6.09	6.33	0.28	6.20	6.40	0.21
4-H	6.81	6.72	6.98	0.17	6.68	6.88	0.07
7-H	3.21	2.92	3.11	0.10	2.98	3.13	0.08
8a-H	1.93	1.10	1.26	0.67	1.76	1.89	0.04
8b-H	1.93	2.08	2.25	0.32	1.68	1.81	0.12
9-H	3.97	3.77	3.97	0.00	4.00	4.16	0.19
10-H	5.13	5.12	5.35	0.22	5.07	5.25	0.12
12-H	1.74	1.70	1.87	0.13	1.69	1.82	0.08
13-H	1.78	1.69	1.86	0.08	1.68	1.81	0.03
14-H	1.20	1.14	1.30	0.10	1.09	1.21	0.01
15-H	2.20	2.06	2.23	0.03	2.03	2.16	0.04
				0.19 <sup>e</sup>			0.09 <sup>e</sup>
				0.28 <sup>f</sup>			0.12 <sup>f</sup>

<sup>a</sup> Data from Ref. 2.<sup>b</sup> Weighted average from the calculated shift for the most stable conformers.<sup>c</sup> Obtained by linear fit of  $\delta_{\text{calcd}}$  versus  $\delta_{\text{exp}}$ .<sup>9</sup><sup>d</sup>  $\varepsilon = |\delta_{\text{exp}} - \delta_{\text{scaled}}|$ .<sup>e</sup> Mean absolute error:  $\Sigma\varepsilon/n$ , where  $n=11$  (number of compared chemical shifts).<sup>f</sup> Standard deviation from linear fit.

**Table 4.** Comparison of experimental <sup>13</sup>C chemical shifts for mutisianthol and calculated data (B3LYP/cc-pVDZ) for structures **2** and **5**

Atoms	<b>2</b>				<b>5</b>		
	δ <sub>exp</sub> <sup>a</sup>	δ <sub>calcd</sub> <sup>b</sup>	δ <sub>scaled</sub> <sup>c</sup>	ε <sup>d</sup>	δ <sub>calcd</sub> <sup>b</sup>	δ <sub>scaled</sub> <sup>c</sup>	ε <sup>d</sup>
1-C	110.1	107.0	105.3	4.8	108.0	106.8	3.3
2-C	152.8	154.3	153.9	1.1	154.0	154.0	1.2
3-C	121.6	123.4	122.4	0.8	122.1	121.3	0.3
4-C	128.6	126.4	125.4	3.2	126.1	125.4	3.2
5-C	138.7	138.3	137.6	1.1	137.0	136.6	2.1
6-C	147.9	147.0	146.5	1.4	148.1	148.0	0.1
7-C	38.1	43.1	40.3	2.2	44.2	41.4	3.3
8-C	42.4	47.7	45.0	2.6	45.9	43.1	0.7
9-C	41.5	47.5	44.8	3.3	46.7	43.9	2.4
10-C	126.3	131.1	130.2	3.9	130.9	130.3	4.0
11-C	131.2	134.3	133.5	2.3	133.4	132.9	1.7
12-C	18.1	18.8	15.5	2.6	18.7	15.2	2.9
13-C	25.8	28.0	24.9	0.9	27.9	24.6	1.2
14-C	20.9	21.0	17.8	3.1	24.1	20.7	0.2
15-C	15.8	19.6	16.3	0.5	19.0	15.5	0.3
				2.26 <sup>e</sup>			1.79 <sup>e</sup>
				2.67 <sup>f</sup>			2.31 <sup>f</sup>

<sup>a</sup> Data from Ref. 2.<sup>b</sup> Weighted average from the calculated shift for the most stable conformers.<sup>c</sup> Obtained by linear fit of δ<sub>calcd</sub> versus δ<sub>exp</sub>.<sup>d</sup> ε = |δ<sub>exp</sub> - δ<sub>scaled</sub>|.<sup>e</sup> Mean absolute error: Σε/n, where n = 11 (number of compared chemical shifts).<sup>f</sup> Standard deviation from the linear fit.

### Acknowledgements

The authors thank the following agencies for financial support: Fundação de Amparo à Pesquisa do Estado de São Paulo (FAPESP), Conselho Nacional de Desenvolvimento Científico e Tecnológico (CNPq) and Coordenadoria de Aperfeiçoamento de Pessoal de Nível Superior (CAPES).

### References and notes

- Bohlmann, F.; Zdero, C. *Phytochemistry* **1977**, *16*, 239.
- Bohlmann, F.; Zdero, C.; Le Van, N. *Phytochemistry* **1979**, *18*, 99.
- Ho, T. L.; Lee, K. Y.; Chen, C. K. *J. Org. Chem.* **1997**, *62*, 3365.
- Hashmi, A. S. K.; Ding, L.; Bats, J. W.; Fischer, P.; Frey, W. *Chem. Eur. J.* **2003**, *9*, 4339.
- Ditchfield, R. *Mol. Phys.* **1974**, *27*, 789.
- Wolinski, K.; Hinton, J. F.; Pulay, P. *J. Am. Chem. Soc.* **1990**, *112*, 8251.
- Barone, G.; Gomez-Paloma, L.; Duca, D.; Silvestri, A.; Riccio, R.; Bifulco, G. *Chem. Eur. J.* **2002**, *8*, 3233.
- Mawhinney, R. C.; Schreckenbach, G. *Magn. Reson. Chem.* **2004**, *42*, S88.
- Cimino, P.; Gomez-Paloma, L.; Duca, D.; Riccio, R.; Bifulco, G. *Magn. Reson. Chem.* **2004**, *42*, S26.
- Jensen, F. *Introduction to Computational Chemistry*; Wiley: Chichester, England, 1999; pp 339–344.
- Young, D. *Computational Chemistry: A Practical Guide for Applying Techniques to Real World Problems*; Wiley: New York, 2001; pp 179–205.
- Chang, G.; Guida, W. C.; Still, W. C. *J. Am. Chem. Soc.* **1989**, *111*, 4379.
- Weinberg, N.; Wolfe, S. *J. Am. Chem. Soc.* **1994**, *116*, 9860.
- Kolossvary, I.; Guida, W. C. *J. Am. Chem. Soc.* **1996**, *118*, 5011.
- Namba, A. M.; Leon, S.; da Silva, G. V. J.; Aleman, C. *Tetrahedron* **2000**, *56*, 6089.
- Wilson, S. R.; Cui, W.; Moskowitz, J. W.; Schmidt, K. E. *J. Comput. Chem.* **1991**, *12*, 342.
- Weiner, P. K.; Profeta, S.; Wipff, G.; Havel, T.; Kuntz, I. D.; Langridge, R.; Kollman, P. A. *Tetrahedron* **1983**, *39*, 1113.
- Brodmeier, T.; Pretsch, E. *J. Comp. Chem.* **1994**, *15*, 588.
- Allinger, N. L.; Zhou, X.; Bergsma, J. *J. Mol. Struct. (Theochem)* **1994**, *312*, 69.
- Macromodel<sup>®</sup> version 7.2; Schrödinger Inc.
- Saunders, M.; Houk, K. N.; Wu, Y.-D.; Still, C.; Lipton, M.; Chang, G.; Guida, W. C. *J. Am. Chem. Soc.* **1990**, *112*, 1419.
- Finley, J. W.; Stephens, P. J. *J. Mol. Struct. (Theochem)* **1995**, *357*, 225–235.
- Frisch, M. J.; Trucks, G. W.; Schlegel, H. B.; Scuseria, G. E.; Robb, M. A.; Cheeseman, J. R.; Zakrzewski, V. G.; Montgomery Jr., J. A.; Stratmann, R. E.; Burant, J. C.; Dapprich, S.; Millam, J. M.; Daniels, A. D.; Kudin, K. N.; Strain, M. C.; Farkas, O.; Tomasi, J.; Barone, V.; Cossi, M.; Cammi, R.; Mennucci, B.; Pomelli, C.; Adamo, C.; Clifford, S.; Ochterski, J.; Petersson, G. A.; Ayala, P. Y.; Cui, Q.; Morokuma, K.; Malick, D. K.; Rabuck, A. D.; Raghavachari, K.; Foresman, J. B.; Cioslowski, J.; Ortiz, J. V.; Baboul, A. G.; Stefanov, B. B.; Liu, G.; Liashenko, A.; Piskorz, P.; Komaromi, I.; Gomperts, R.; Martin, R. L.; Fox, D. J.; Keith, T.; Al-Laham, M. A.; Peng, C. Y.; Nanayakkara, A.; Gonzalez, C.; Challacombe, M.; Gill, P. M. W.; Johnson, B. G.; Chen, W.; Wong, M. W.; Andres, J. L.; Head-Gordon, M.; Replogle, E. S.; Pople, J. A. *Gaussian 98 (Revision A.7)*, Gaussian Inc.: Pittsburgh PA, 1998.
- Tomasi, J.; Mennucci, B. *Encycl. Comput. Chem.* **1998**, *4*, 2547.
- Ditchfield, R.; Hehre, W. J.; Pople, J. A. *J. Chem. Phys.* **1971**, *54*, 724.
- Cheeseman, J. R.; Trucks, G. W.; Keith, T. A.; Frisch, M. J. *J. Chem. Phys.* **1996**, *104*, 5497.
- Dunning, T. H. *J. Chem. Phys.* **1971**, *55*, 716.
- GaussView 3.0, Gaussian Inc.: Cornege Office Park-Building 6, Pittsburg, PA 15106, USA.

# Stereoselective *Z*-iodoalkoxylation of 1,2-allenyl sulfides or selenides

Chunling Fu,<sup>a</sup> Guofei Chen,<sup>a</sup> Xiaoyi Liu<sup>a</sup> and Shengming Ma<sup>a,b,\*</sup>

<sup>a</sup>Laboratory of Molecular Recognition and Synthesis, Department of Chemistry, Zhejiang University, Hangzhou 310027, Zhejiang, People's Republic of China

<sup>b</sup>State Key Laboratory of Organometallic Chemistry, Shanghai Institute of Organic Chemistry, Chinese Academy of Sciences, 354 Fenglin Lu, Shanghai 200032, People's Republic of China

Received 11 April 2005; revised 23 May 2005; accepted 25 May 2005

Available online 22 June 2005

**Abstract**—Iodoalkylation of 1,2-allenyl sulfides or selenides with I<sub>2</sub> in MeCN/ROH (20:1) afforded *Z*-3-alkoxy-2-iodopropenyl sulfides or selenides in high stereoselectivity and moderate to good yields. The carbon–iodine bonds in these compounds may undergo Suzuki, Negishi, and Sonogashira coupling reaction smoothly.

© 2005 Elsevier Ltd. All rights reserved.

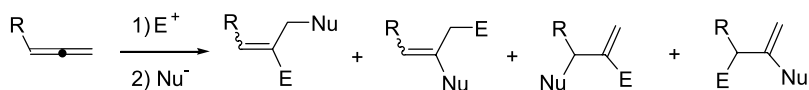
## 1. Introduction

Electrophilic addition of allenes is an interesting reaction since usually two different functionalities can be introduced within one operation. However, the regio- and stereoselectivity is usually low, which makes these reactions synthetically unattractive (Scheme 1).<sup>1</sup>

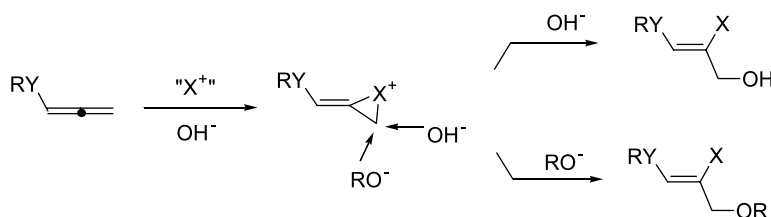
Recently, we have applied the strategy of introducing heteroatoms into allenes to control the regio- and stereoselectivity of the halohydroxylation of allenes.<sup>2–4</sup> With 1,2-allenyl sulfoxides, *E*-halohydroxylation was realized by

the participation of the sulfinyl oxygen<sup>2</sup> while the *Z*-halohydroxylation of 1-sulfur or selenium-substituted allene was probably controlled by the Lewis acid–base interaction between X<sup>+</sup> and sulfur or selenium atom.<sup>3–5</sup>

Based on the *Z*-halohydroxylation results of 1,2-allenyl sulfides and selenides, we reasoned that if the reaction is conducted in the presence of a nucleophile<sup>6</sup> other than water, the nucleophile can be introduced instead of the hydroxyl group (Scheme 2). In this paper, we wish to report our recent observation of using alcohols as the nucleophile.<sup>7</sup>



Scheme 1.



Scheme 2.

**Keywords:** Iodoalkoxylation; Allenes; Sulfides; Selenides; Coupling.

\* Corresponding author. Address: State Key Laboratory of Organometallic Chemistry, Shanghai Institute of Organic Chemistry, Chinese Academy of Sciences, 354 Fenglin Lu, Shanghai 200032, People's Republic of China. Tel.: +86 21 64163300; fax: +86 21 64167510; e-mail: masm@mail.sioc.ac.cn

**Table 1.** Iodoethoxylation reaction of **1a** under different conditions<sup>a</sup>

Entry	CH <sub>3</sub> CN/EtOH	Time (h)	Yield (%) <sup>b</sup>
1	1:1	1.5	59
2	4:1	1.5	50
3	9:1	1	55
4	27:1	1.5	17
5	20:1	1	68
6 <sup>c</sup>	20:1	2.5	48
7 <sup>d</sup>	20:1	1	45
8 <sup>e</sup>	20:1	1	54
9 <sup>f</sup>	20:1	1	54

<sup>a</sup> The reaction was conducted using 0.25 mmol of **1a**, 0.5 mmol of I<sub>2</sub> and EtOH (0.25 mL).

<sup>b</sup> Isolated yield.

<sup>c</sup> The reaction was conducted at 0 °C.

<sup>d</sup> The reaction was conducted at 30 °C.

<sup>e</sup> 1.5 equiv of I<sub>2</sub> were used.

<sup>f</sup> 3 equiv of I<sub>2</sub> were applied.

**Table 2.** Reaction of **1** with different alcohols<sup>a</sup>

Entry	Ar	X	ROH	Yield (%) <sup>b</sup>
1	Ph	Se	EtOH	68 ( <b>2a</b> )
2	Ph	Se	<i>i</i> -Butanol	63 ( <b>2b</b> )
3	Ph	Se	Pentanol	76 ( <b>2c</b> )
4	Ph	Se	Cyclohexanol	80 ( <b>2d</b> )
5	Ph	Se	BnOH	77 ( <b>2e</b> )
6	Bn	Se	EtOH	64 ( <b>2f</b> )
7	Ph	S	EtOH	49 ( <b>2g</b> )

<sup>a</sup> The reaction was conducted with substrate I<sub>2</sub> (2 equiv) and CH<sub>3</sub>CN/ROH 20:1 at room temperature for 1 h.

<sup>b</sup> Isolated yield.

## 2. Results and discussion

We tried the reaction of 1,2-propadienyl phenyl selenide with EtOH and I<sub>2</sub>. In the presence of 2 equiv of I<sub>2</sub>, the effect of the ratio of MeCN/EtOH on the reaction was studied (entries 1–5, Table 1). Best result was obtained with a ratio of MeCN/EtOH of 20:1 to afford **2a** in 68% yield (entry 5, Table 1).

The reaction at a lower or higher temperature afforded the product **2a** in relatively lower yields (entries 6 and 7, Table 1). With 1.5 or 3 equiv of I<sub>2</sub>, the yields of **2a** were also lower (54%) (entries 8 and 9, Table 1).

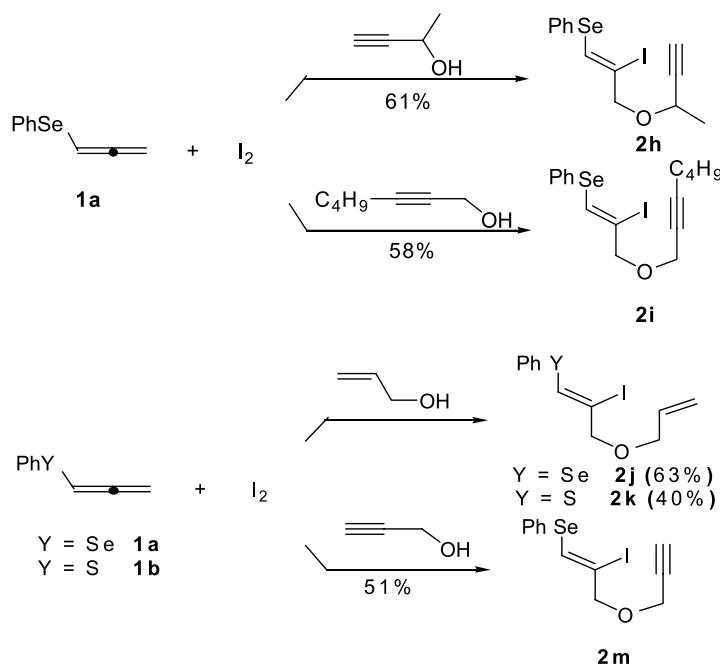
With the standard reaction conditions in hand, we studied the effect of the structure of alcohols on the reaction with some of the typical examples listed in Table 2. In all these cases, the reaction afforded the products, that is, 2(*Z*)-iodoallylic ethers **2a–g** highly stereoselectively in moderate to good yields.

Furthermore, it is interesting to observe that allyl alcohol and propargyl alcohol can also react similarly affording the corresponding allylic or propargylic ethers **2h–2m** in reasonable yields (Scheme 3).

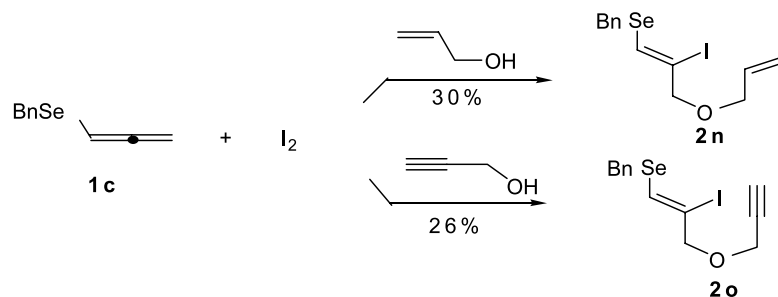
However, the reaction of the corresponding benzyl selenide afforded products in much lower yields (Scheme 4).

The stereoselectivity, which was determined by the NOE study of **2a**, is similar to what was observed with the halohydroxylation,<sup>3,4</sup> affording the *Z*-isomers highly stereoselectively.

The carbon–iodine bond in **2a** can undergo Suzuki coupling<sup>8</sup> (Table 3), Sonogashira coupling reaction<sup>9</sup> and Negishi coupling<sup>10</sup> (Scheme 5) to afford the stereodefined allylic ethers **3aa–3af**.

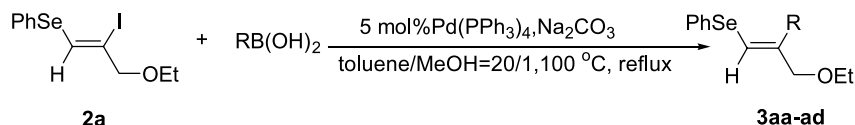
**Scheme 3.**



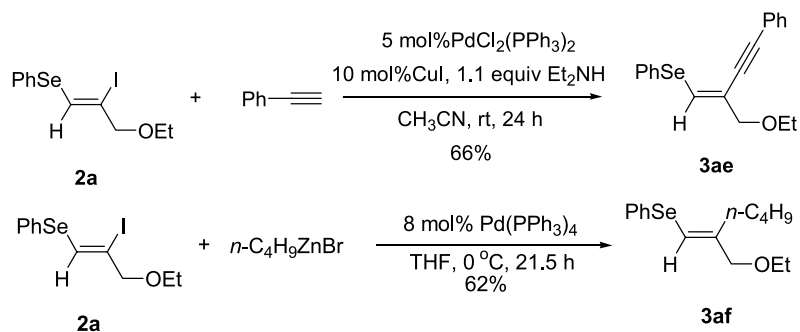


Scheme 4.

Table 3. Suzuki coupling reaction of 2a



Entry	R	Time (h)	Yield (%)
1	Ph	22.5	79 (3aa)
2	4-MeOC <sub>6</sub> H <sub>4</sub>	17.5	76 (3ab)
3	4-MeC <sub>6</sub> H <sub>4</sub>	17.5	75 (3ac)
4	4-MeCOC <sub>6</sub> H <sub>4</sub>	22.5	39 (3ad)



Scheme 5.

In conclusion, we have shown that the alcohol can act as a nucleophile in electrophilic addition of I<sub>2</sub> with 1,2-allenyl selenides or sulfides. Due to the high stereoselectivity and easy availability of starting materials, this method further expanded the scope of the stereoselective electrophilic addition of 1,2-allenyl sulfides or selenides with halogen. Further studies in this area, are being carried out in our laboratory.

### 3. Experimental

#### 3.1. Typical procedure for the synthesis of 2a

A solution of 1a (50.4 mg, 0.26 mmol) and iodine (128.3 mg, 0.5 mmol) in 5 mL of MeCN and 0.25 mL of EtOH (20:1) was stirred at room temperature for 1 h. The mixture was quenched with a saturated aqueous solution of Na<sub>2</sub>S<sub>2</sub>O<sub>3</sub>. The mixture was then extracted with diethyl ether (25 mL × 3) and dried over anhydrous Na<sub>2</sub>SO<sub>4</sub>. Evaporation and column chromatography on silica gel (petroleum ether/ethyl acetate 200:1) afforded 2a (64.7 mg, 68%) as a liquid.

**3.1.1. Synthesis of (Z)-3-ethoxy-2-iodopropenyl phenyl selenide (2a).** The reaction of 50.4 mg (0.26 mmol) of 1a

and 128.3 mg (0.51 mmol) of I<sub>2</sub> in 5 mL of MeCN and 0.25 mL of EtOH (20:1) afforded 64.7 mg (68%) of 2a: liquid.

<sup>1</sup>H NMR (400 MHz, CDCl<sub>3</sub>) δ 7.53–7.51 (m, 2H), 7.35 (s, 1H), 7.27–7.19 (m, 3H), 4.04 (s, 2H), 3.42 (q, *J* = 7.0 Hz, 2H), 1.16 (t, *J* = 7.0 Hz, 3H); <sup>13</sup>C NMR (100 MHz, CDCl<sub>3</sub>) δ 133.6, 133.5, 129.5, 129.4, 128.1, 102.4, 78.7, 65.4, 15.1; MS (70 eV, EI) *m/z* (%): 368 (M<sup>+</sup>(<sup>80</sup>Se), 35.40), 366 (M<sup>+</sup>(<sup>78</sup>Se), 18.46), 83 (100); IR *ν* (cm<sup>-1</sup>): 3056, 1580, 1476, 1439, 1104, 737. Anal. Calcd for C<sub>11</sub>H<sub>13</sub>IOSe: C, 35.99; H, 3.57. Found: C, 36.29; H, 3.53.

**3.1.2. Synthesis of (Z)-3-isobutoxy-2-iodopropenyl phenyl selenide (2b).** The reaction of 51.5 mg (0.26 mmol) of 1a and 123.6 mg (0.49 mmol) of I<sub>2</sub> in 5 mL of MeCN and 0.25 mL of *i*-butanol (20:1) afforded 65.4 mg (63%) of 2b: liquid.

<sup>1</sup>H NMR (400 MHz, CDCl<sub>3</sub>) δ 7.61–7.59 (m, 2H), 7.43 (s, 1H), 7.34–7.32 (m, 3H), 4.11 (s, 2H), 3.20 (d, *J* = 6.4 Hz, 2H), 1.91–1.87 (m, 1H), 0.95 (t, *J* = 6.8 Hz, 6H); <sup>13</sup>C NMR (100 MHz, CDCl<sub>3</sub>) δ 133.5, 133.4, 129.5, 129.4, 128.0, 102.7, 78.9, 76.7, 28.4, 19.4; MS (70 eV, EI) *m/z* (%): 396

(M<sup>+</sup>(<sup>80</sup>Se), 8.45), 394 (M<sup>+</sup>(<sup>78</sup>Se), 4.83), 57 (100); IR (neat)  $\nu$  (cm<sup>-1</sup>): 2955, 2870, 1578, 1475, 1438, 1103, 737; HRMS calcd for C<sub>13</sub>H<sub>17</sub>IO<sup>80</sup>Se: 395.9489. Found: 395.9475.

**3.1.3. Synthesis of (Z)-3-pentoxy-2-iodopropenyl phenyl selenide (2c).** The reaction of 52.4 mg (0.27 mmol) of **1a** and 130.3 mg (0.51 mmol) of I<sub>2</sub> in 5 mL of MeCN and 0.25 mL of pentanol (20:1) afforded 83.1 mg (76%) of **2c**: liquid.

<sup>1</sup>H NMR (400 MHz, CDCl<sub>3</sub>)  $\delta$  7.60–7.58 (m, 2H), 7.42 (s, 1H), 7.34–7.32 (m, 3H), 4.10 (s, 2H), 3.41 (t, *J* = 6.4 Hz, 2H), 1.61–1.58 (m, 2H), 1.35–1.32 (m, 4H), 0.89 (t, *J* = 6.4 Hz, 3H); <sup>13</sup>C NMR (100 MHz, CDCl<sub>3</sub>)  $\delta$  133.54, 133.49, 129.5, 129.4, 128.1, 102.6, 78.9, 70.1, 29.3, 28.3, 22.5, 14.0; MS (70 eV, EI) *m/z* (%): 410 (M<sup>+</sup>(<sup>80</sup>Se), 14.32), 408 (M<sup>+</sup>(<sup>78</sup>Se), 8.24), 43 (100); IR (neat)  $\nu$  (cm<sup>-1</sup>): 2954, 2930, 2858, 1578, 1476, 1105, 736; HRMS calcd for C<sub>14</sub>H<sub>19</sub>IO<sup>80</sup>Se: 409.9646. Found: 409.9675.

**3.1.4. Synthesis of (Z)-3-cyclohexoxy-2-iodopropenyl phenyl selenide (2d).** The reaction of 47.2 mg (0.25 mmol) of **1a** and 131.4 mg (0.5 mmol) of I<sub>2</sub> in 5 mL of MeCN and 0.3 mL of cyclohexanol (20:1) afforded 81.5 mg (80%) of **2d**: liquid.

<sup>1</sup>H NMR (400 MHz, CDCl<sub>3</sub>)  $\delta$  7.60–7.57 (m, 2H), 7.42 (s, 1H), 7.33–7.31 (m, 3H), 4.14 (s, 2H), 3.36–3.32 (m, 1H), 1.89–1.86 (m, 2H), 1.75–1.71 (m, 2H), 1.53–1.51 (m, 1H), 1.34–1.21 (m, 5H); <sup>13</sup>C NMR (100 MHz, CDCl<sub>3</sub>)  $\delta$  133.4, 132.7, 129.7, 129.4, 128.0, 103.5, 76.9, 76.1, 32.2, 25.7, 24.0; MS (70 eV, EI) *m/z* (%): 422 (M<sup>+</sup>(<sup>80</sup>Se), 15.98), 420 (M<sup>+</sup>(<sup>78</sup>Se), 9.07), 55 (100); IR (neat)  $\nu$  (cm<sup>-1</sup>): 2930, 2854, 1578, 1477, 1438, 1098, 736, 690; HRMS for C<sub>15</sub>H<sub>19</sub>IO<sup>80</sup>Se: 421.9646. Found: 421.9686.

**3.1.5. Synthesis of (Z)-3-benzyloxy-2-iodopropenyl phenyl selenide (2e).** The reaction of 47.1 mg (0.25 mmol) of **1a** and 132.4 mg (0.5 mmol) of I<sub>2</sub> in 5 mL of MeCN and 0.3 mL of benzyl alcohol (20:1) afforded 79.5 mg (77%) of **2e**: liquid.

<sup>1</sup>H NMR (400 MHz, CDCl<sub>3</sub>)  $\delta$  7.62–7.60 (m, 2H), 7.48 (s, 1H), 7.37–7.30 (m, 8H), 4.54 (s, 2H), 4.18 (s, 2H); <sup>13</sup>C NMR (100 MHz, CDCl<sub>3</sub>)  $\delta$  137.5, 134.5, 133.6, 133.5, 129.5, 128.4, 128.1, 127.9, 127.8, 101.8, 78.0, 71.5; MS (70 eV, EI) *m/z* (%): 430 (M<sup>+</sup>(<sup>80</sup>Se), 4.37), 428 (M<sup>+</sup>(<sup>78</sup>Se), 2.43), 91 (100); IR (neat)  $\nu$  (cm<sup>-1</sup>): 2855, 1578, 1496, 1438, 1096, 735, 692; HRMS calcd for C<sub>16</sub>H<sub>15</sub>IO<sup>80</sup>Se: 429.9333. Found: 429.9377.

**3.1.6. Synthesis of (Z)-3-ethoxy-2-iodopropenyl benzyl selenide (2f).** The reaction of 52.9 mg (0.26 mmol) of **1c** and 128.3 mg (0.5 mmol) of I<sub>2</sub> in 5 mL of MeCN and 0.25 mL of EtOH (20:1) afforded 61.0 mg (64%) of **2f**: liquid.

<sup>1</sup>H NMR (400 MHz, CDCl<sub>3</sub>)  $\delta$  7.24–7.23 (m, 4H), 7.17–7.15 (m, 2H), 3.96 (s, 4H), 3.33 (q, *J* = 7.2 Hz, 2H), 1.12 (t, *J* = 7.2 Hz, 3H); <sup>13</sup>C NMR (100 MHz, CDCl<sub>3</sub>)  $\delta$  138.2, 131.0, 128.8, 128.7, 127.2, 102.6, 78.7, 65.2, 29.8, 15.0; MS (70 eV, EI) *m/z* (%): 382 (M<sup>+</sup>(<sup>80</sup>Se), 3.7), 380 (M<sup>+</sup>(<sup>78</sup>Se), 1.5), 91 (100); IR  $\nu$  (cm<sup>-1</sup>): 2972, 2926, 2868, 1584, 1494,

1453, 1103, 697; HRMS calcd for C<sub>12</sub>H<sub>15</sub>IO<sup>80</sup>Se: 381.9333. Found: 381.9360.

**3.1.7. Synthesis of (Z)-3-ethoxy-2-iodopropenyl phenyl sulfide (2g).** The reaction of 74.6 mg (0.5 mmol) of **1b** and 259.4 mg (1.02 mmol) of I<sub>2</sub> in 8 mL of MeCN and 0.4 mL of EtOH (20:1) afforded 79.0 mg (49%) of **2g**: liquid.

<sup>1</sup>H NMR (400 MHz, CDCl<sub>3</sub>)  $\delta$  7.45 (d, *J* = 1.2 Hz, 2H), 7.36–7.29 (m, 3H), 7.03 (s, 1H), 4.16 (d, *J* = 1.2 Hz, 2H), 3.50 (q, *J* = 7.2 Hz, 2H), 1.23 (t, *J* = 7.2 Hz, 3H); <sup>13</sup>C NMR (100 MHz, CDCl<sub>3</sub>)  $\delta$  135.0, 133.9, 130.8, 129.3, 127.7, 98.7, 78.1, 65.4, 15.1; MS (70 eV, EI) *m/z* (%): 320 (M<sup>+</sup>, 36.38), 83 (100); IR (neat)  $\nu$  (cm<sup>-1</sup>): 2974, 2926, 2869, 1578, 1476, 1439, 1105, 742, 691; HRMS calcd for C<sub>11</sub>H<sub>13</sub>IOS: 319.9732. Found: 319.9750.

**3.1.8. Synthesis of (Z)-3-(3'-butyn-2'-oxy)-2-iodopropenyl phenyl selenide (2h).** The reaction of 49.1 mg (0.25 mmol) of **1a** and 131.7 mg (0.51 mmol) of I<sub>2</sub> in 5 mL of MeCN and 0.25 mL of but-3-yn-2-ol (20:1) afforded 60.1 mg (61%) of **2h**: liquid.

<sup>1</sup>H NMR (400 MHz, CDCl<sub>3</sub>)  $\delta$  7.61–7.58 (m, 2H), 7.49 (s, 1H), 7.34–7.32 (m, 3H), 4.31 (d, *J* = 13.0 Hz, 1H), 4.22 (d, *J* = 13.0 Hz, 1H), 4.23–4.20 (m, 1H), 2.42 (s, 1H), 1.48 (d, *J* = 6.4 Hz, 3H); <sup>13</sup>C NMR (100 MHz, CDCl<sub>3</sub>)  $\delta$  135.3, 133.5, 129.5, 129.4, 128.1, 101.0, 82.9, 76.4, 73.5, 63.6, 21.9; MS (70 eV, EI) *m/z* (%): 392 (M<sup>+</sup>(<sup>80</sup>Se), 29.35), 390 (M<sup>+</sup>(<sup>78</sup>Se), 15.77), 53 (100); IR (neat)  $\nu$  (cm<sup>-1</sup>): 3292, 2986, 2109, 1577, 1099, 739; HRMS calcd for C<sub>13</sub>H<sub>13</sub>IO<sup>80</sup>SeNa<sup>+</sup>: 414.9069. Found: 414.9077.

**3.1.9. Synthesis of (Z)-3-(hept-2'-ynoxy)-2-iodopropenyl phenyl selenide (2i).** The reaction of 47.1 mg (0.25 mmol) of **1a** and 127.1 mg (0.50 mmol) of I<sub>2</sub> in 5 mL of MeCN and 0.25 mL of Hept-2-yn-1-ol (20:1) afforded 61.2 mg (58%) of **2i**: liquid.

<sup>1</sup>H NMR (400 MHz, CDCl<sub>3</sub>)  $\delta$  7.61–7.58 (m, 2H), 7.49–7.48 (m, 1H), 7.33–7.31 (m, 3H), 4.22 (s, 2H), 4.15 (s, 2H), 2.20 (t, *J* = 6.8 Hz, 2H), 1.49–1.35 (m, 4H), 0.88 (t, *J* = 7.0 Hz, 3H); <sup>13</sup>C NMR (100 MHz, CDCl<sub>3</sub>)  $\delta$  135.2, 133.5, 129.4, 128.1, 100.7, 87.8, 77.0, 75.1, 57.1, 30.6, 21.9, 18.4, 13.5; MS (70 eV, EI) *m/z* (%): 434 (M<sup>+</sup>(<sup>80</sup>Se), 2.1), 432 (M<sup>+</sup>(<sup>78</sup>Se), 1.2), 235 (100); IR (neat)  $\nu$  (cm<sup>-1</sup>): 2956, 2930, 2221, 1578, 1091, 739; HRMS calcd for C<sub>16</sub>H<sub>19</sub>IO<sup>80</sup>SeNa<sup>+</sup>: 456.9544. Found: 456.9555.

**3.1.10. Synthesis of (Z)-3-allyloxy-2-iodopropenyl phenyl selenide (2j).** The reaction of 98.8 mg (0.51 mmol) of **1a** and 255.0 mg (1.00 mmol) of I<sub>2</sub> in 8 mL of MeCN and 0.4 mL of allyl alcohol (20:1) afforded 121.5 mg (63%) of **2j**: liquid.

<sup>1</sup>H NMR (400 MHz, CDCl<sub>3</sub>)  $\delta$  7.60–7.58 (m, 2H), 7.44 (s, 1H), 7.35–7.32 (m, 3H), 5.95–5.88 (m, 1H), 5.29 (d, *J* = 18.0 Hz, 1H), 5.20 (d, *J* = 10.4 Hz, 1H), 4.13 (s, 2H), 4.00 (d, *J* = 5.6 Hz, 2H); <sup>13</sup>C NMR (100 MHz, CDCl<sub>3</sub>)  $\delta$  134.11, 134.07, 133.5, 129.5, 129.4, 128.1, 117.6, 101.7, 78.0, 70.6; MS (70 eV, EI) *m/z* (%): 380 (M<sup>+</sup>(<sup>80</sup>Se), 18.11), 378 (M<sup>+</sup>(<sup>78</sup>Se), 9.41), 41 (100); IR (neat)  $\nu$  (cm<sup>-1</sup>): 2924, 2852,

1645, 1578, 1477, 1438, 1095, 1022, 738. Anal. Calcd for  $C_{12}H_{13}IOSe$ : C, 38.02; H, 3.46. Found: C, 38.28; H, 3.61.

**3.1.11. Synthesis of (Z)-3-allyloxy-2-iodopropenyl phenyl sulfide (2k).** The reaction of 82.1 mg (0.55 mmol) of **1b** and 255.5 mg (1.01 mmol) of  $I_2$  in 8 mL of MeCN and 0.4 mL of allyl alcohol (20:1) afforded 74.4 mg (40%) of **2k**: liquid.

$^1H$  NMR (400 MHz,  $CDCl_3$ )  $\delta$  7.45–7.44 (m, 2H), 7.36–7.28 (m, 3H), 7.06 (s, 1H), 5.96–5.89 (m, 1H), 5.31 (d,  $J=17.6$  Hz, 1H), 5.21 (d,  $J=10.0$  Hz, 1H), 4.19 (s, 2H), 4.01 (d,  $J=6.0$  Hz, 2H);  $^{13}C$  NMR (100 MHz,  $CDCl_3$ )  $\delta$  135.3, 134.1, 133.7, 130.8, 129.2, 127.7, 117.6, 97.9, 77.3, 70.6; MS (70 eV, EI)  $m/z$  (%): 332 ( $M^+$ , 28.53), 41 (100); IR (neat)  $\nu$  ( $cm^{-1}$ ): 2852, 1646, 1581, 1477, 1440, 1097, 743, 691; HRMS calcd for  $C_{12}H_{13}IOS$ : 331.9732. Found: 331.9688.

**3.1.12. Synthesis of (Z)-3-(prop-2'-ynoxy)-2-iodopropenyl phenyl selenide (2m).** The reaction of 53.8 mg (0.28 mmol) of **1a** and 129.8 mg (0.51 mmol) of  $I_2$  in 5 mL of MeCN and 0.25 mL of prop-2-ynol (20:1) afforded 53.1 mg (51%) of **2m**: liquid.

$^1H$  NMR (400 MHz,  $CDCl_3$ )  $\delta$  7.61–7.59 (m, 2H), 7.51 (s, 1H), 7.35–7.33 (m, 3H), 4.24 (s, 2H), 4.17 (d,  $J=2.4$  Hz, 2H), 2.44 (t,  $J=2.4$  Hz, 1H);  $^{13}C$  NMR (100 MHz,  $CDCl_3$ )  $\delta$  135.9, 133.6, 129.5, 129.4, 128.2, 100.0, 79.0, 77.3, 75.1, 56.5; MS (70 eV, EI)  $m/z$  (%): 378 ( $M^+$  ( $^{80}Se$ ), 40.63), 376 ( $M^+$  ( $^{78}Se$ ), 20.66), 221 (100); IR (neat)  $\nu$  ( $cm^{-1}$ ): 3292, 2361, 1579, 1476, 1439, 1348, 1095, 738. Anal. Calcd for  $C_{12}H_{11}IOSe$ : C, 38.22; H, 2.94. Found: C, 38.39; H, 3.02.

**3.1.13. Synthesis of (Z)-3-allyloxy-2-iodopropenyl benzyl selenide (2n).** The reaction of 87.1 mg (0.42 mmol) of **1c** and 222.1 mg (0.87 mmol) of  $I_2$  in 8 mL of MeCN and 4 mL of allyl alcohol (20:1) afforded 49.8 mg (30%) of **2n**: liquid.

$^1H$  NMR (400 MHz,  $CDCl_3$ )  $\delta$  7.35–7.23 (m, 6H), 5.92–5.85 (m, 1H), 5.24 (d,  $J=17.6$  Hz, 1H), 5.20 (d,  $J=10.4$  Hz, 1H), 4.07 (s, 2H), 4.05 (s, 2H), 3.93 (d,  $J=5.2$  Hz, 2H);  $^{13}C$  NMR (100 MHz,  $CDCl_3$ )  $\delta$  138.2, 134.1, 131.6, 128.8, 128.7, 127.2, 117.6, 101.9, 77.9, 70.4, 29.8; MS (70 eV, EI)  $m/z$  (%): 394 ( $M^+$  ( $^{80}Se$ ), 2.1), 392 ( $M^+$  ( $^{78}Se$ ), 1.1), 91 (100); IR  $\nu$  ( $cm^{-1}$ ): 3026, 2852, 1646, 1583, 1494, 1453, 1183, 1094, 759, 697; HRMS calcd for  $C_{13}H_{15}IO^{80}Se$ : 393.9333. Found: 393.9367.

**3.1.14. Synthesis of (Z)-3-(prop-2'-ynoxy)-2-iodopropenyl benzyl selenide (2o).** The reaction of 86.1 mg (0.41 mmol) of **1c** and 205.2 mg (0.81 mmol) of  $I_2$  in 8 mL of MeCN and 0.4 mL of prop-2-ynol (20:1) afforded 41.1 mg (26%) of **2o**: liquid.

$^1H$  NMR (400 MHz,  $CDCl_3$ )  $\delta$  7.31–7.19 (m, 6H), 4.13 (s, 2H), 4.05 (d,  $J=2.4$  Hz, 2H), 4.01 (s, 2H), 2.39 (t,  $J=2.4$  Hz, 1H);  $^{13}C$  NMR (100 MHz,  $CDCl_3$ )  $\delta$  137.9, 133.5, 128.6, 128.5, 127.1, 100, 1, 78.8, 76.5, 74.8, 56.0, 29.7; MS (70 eV, EI)  $m/z$  (%): 392 ( $M^+$  ( $^{80}Se$ ), 1.1), 390 ( $M^+$  ( $^{78}Se$ ), 0.5), 91 (100); IR  $\nu$  ( $cm^{-1}$ ): 3291, 2849, 2247, 1582, 1494, 1453, 1095, 1047, 732, 697; HRMS calcd for  $C_{13}H_{13}IO^{80}Se$ : 391.9176. Found: 391.9176.

**3.1.15. Synthesis of (E)-3-ethoxy-2-phenylpropenyl phenyl selenide (3aa).** The reaction of 100.6 mg (0.27 mmol) of **2a**, phenyl boronic acid (60.6 mg, 0.51 mmol),  $Pd(PPh_3)_4$  (14.7 mg, 5 mol%),  $CH_3OH$  (0.1 mL) and  $Na_2CO_3$  (0.3 mL, 2 M in  $H_2O$ ) in 2 mL of toluene was refluxed under  $N_2$  for 22.5 h as monitored by TLC (petroleum ether/ethyl acetate 40:1). Water (10 mL) was added and the reaction mixture was extracted with ether, washed with saturated NaCl, and dried over anhydrous  $Na_2SO_4$ . Filtration, evaporation, and column chromatography on silica gel afforded 68.5 mg (79%) of **3aa** as an oil.

$^1H$  NMR (400 MHz,  $CDCl_3$ )  $\delta$  7.56–7.54 (m, 2H), 7.42–7.41 (m, 4H), 7.34–7.29 (m, 4H), 6.84 (s, 1H), 4.30 (s, 2H), 3.56 (q,  $J=7.0$  Hz, 2H), 1.21 (t,  $J=7.0$  Hz, 3H);  $^{13}C$  NMR (100 MHz,  $CDCl_3$ )  $\delta$  139.3, 138.9, 132.4, 131.3, 129.2, 128.4, 127.8, 127.6, 127.3, 122.3, 74.8, 65.5, 15.1; MS (70 eV, EI)  $m/z$  (%): 318 ( $M^+$  ( $^{80}Se$ ), 56.16), 316 ( $M^+$  ( $^{78}Se$ ), 29.21), 133 (100); IR (neat)  $\nu$  ( $cm^{-1}$ ): 2973, 2926, 2866, 1578, 1158, 1098, 697; HRMS calcd for  $C_{17}H_{19}O^{80}Se^+$  ( $M^+$  + H): 319.0596. Found: 319.0593.

**3.1.16. Synthesis of (E)-3-ethoxy-2-(4'-methoxyphenyl)propenyl phenyl selenide (3ab).** The reaction of 88.9 mg (0.24 mmol) of **2a**, *p*-methoxy-phenyl boronic acid (72.6 mg, 0.48 mmol),  $Pd(PPh_3)_4$  (15.1 mg, 5 mol%),  $CH_3OH$  (0.1 mL) and  $Na_2CO_3$  (0.3 mL, 2 M in  $H_2O$ ) in 2 mL of toluene afforded 64.2 mg (76%) of **3ab** as an oil.

$^1H$  NMR (400 MHz,  $CDCl_3$ )  $\delta$  7.56–7.53 (m, 2H), 7.36–7.26 (m, 5H), 6.95 (d,  $J=8.4$  Hz, 2H), 6.77 (s, 1H), 4.28 (s, 2H), 3.84 (s, 3H), 3.54 (q,  $J=7.1$  Hz, 2H), 1.21 (t,  $J=7.1$  Hz, 3H);  $^{13}C$  NMR (100 MHz,  $CDCl_3$ )  $\delta$  159.0, 138.8, 132.4, 131.4, 131.1, 129.1, 128.9, 127.2, 121.4, 113.7, 74.9, 65.4, 55.1, 15.1; MS (70 eV, EI)  $m/z$  (%): 348 ( $M^+$  ( $^{80}Se$ ), 94.27), 346 ( $M^+$  ( $^{78}Se$ ), 48.73), 163 (100); IR (neat)  $\nu$  ( $cm^{-1}$ ): 2972, 1607, 1510, 1248; HRMS calcd for  $C_{18}H_{21}O_2^{80}Se^+$  ( $M^+$  + H): 349.0701. Found: 349.0702.

**3.1.17. Synthesis of (E)-3-ethoxy-2-(4'-methylphenyl)propenyl phenyl selenide (3ac).** The reaction of 88.3 mg (0.24 mmol) of **2a**, *p*-methylphenyl boronic acid (66.3 mg, 0.49 mmol),  $Pd(PPh_3)_4$  (18.4 mg, 6 mol%),  $CH_3OH$  (0.1 mL) and  $Na_2CO_3$  (0.3 mL, 2 M in  $H_2O$ ) in 2 mL of toluene was afforded 59.9 mg (75%) of **3ac** as an oil.

$^1H$  NMR (400 MHz,  $CDCl_3$ )  $\delta$  7.56–7.54 (m, 2H), 7.31–7.22 (m, 7H), 6.81 (s, 1H), 4.29 (s, 2H), 3.55 (q,  $J=7.0$  Hz, 2H), 2.39 (s, 3H), 1.21 (t,  $J=7.0$  Hz, 3H);  $^{13}C$  NMR (100 MHz,  $CDCl_3$ )  $\delta$  139.3, 137.6, 135.9, 132.4, 131.4, 129.14, 129.11, 127.5, 127.2, 121.6, 74.8, 65.5, 21.3, 15.1; MS (70 eV, EI)  $m/z$  (%): 332 ( $M^+$  ( $^{80}Se$ ), 100), 330 ( $M^+$  ( $^{78}Se$ ), 51.40); IR (neat)  $\nu$  ( $cm^{-1}$ ): 2973, 2865, 1578, 1511, 1120, 737; HRMS calcd for  $C_{18}H_{21}O^{80}Se^+$  ( $M^+$  + H): 333.0752. Found: 333.0748.

**3.1.18. Synthesis of (E)-3-ethoxy-2-(4'-acetylphenyl)propenyl phenyl selenide (3ad).** The reaction of 96.9 mg (0.26 mmol) of **2a**, *p*-acetylphenyl boronic acid (86.4 mg, 0.53 mmol),  $Pd(PPh_3)_4$  (21.6 mg, 6 mol%),  $CH_3OH$  (0.1 mL) and  $Na_2CO_3$  (0.3 mL, 2 M in  $H_2O$ ) in 2 mL of toluene afforded 36.9 mg (39%) of **3ad** as an oil.

$^1\text{H}$  NMR (400 MHz,  $\text{CDCl}_3$ )  $\delta$  8.00 (d,  $J=8.4$  Hz, 2H), 7.55–7.50 (m, 4H), 7.31–7.30 (m, 3H), 6.92 (s, 1H), 4.29 (s, 2H), 3.52 (q,  $J=7.0$  Hz, 2H), 2.62 (s, 3H), 1.18 (t,  $J=7.0$  Hz, 3H);  $^{13}\text{C}$  NMR (100 MHz,  $\text{CDCl}_3$ )  $\delta$  197.6, 143.8, 138.0, 136.2, 132.7, 130.8, 129.3, 128.5, 127.9, 127.6, 124.9, 74.7, 65.6, 26.6, 15.1; MS (70 eV, EI)  $m/z$  (%): 360 ( $\text{M}^+(\text{}^{80}\text{Se})$ , 96.22), 358 ( $\text{M}^+(\text{}^{78}\text{Se})$ , 49.10), 115 (100); IR (neat)  $\nu$  ( $\text{cm}^{-1}$ ): 2973, 2866, 1683, 1603, 1578, 1266, 1095, 847, 739, 691; HRMS calcd for  $\text{C}_{19}\text{H}_{21}\text{O}_2\text{Se}^+$  ( $\text{M}^+ + \text{H}$ ): 361.0701. Found: 361.0719.

**3.1.19. Synthesis of (*E*)-3-ethoxy-2-(phenylethynyl)propenyl phenyl selenide (3ae).** A mixture of 87.3 mg (0.24 mmol) of **2a**, phenylacetylene (38.9 mg, 0.38 mmol),  $\text{Et}_2\text{NH}$  (21.1 mg, 0.289 mmol),  $\text{CuI}$  (5.7 mg, 10 mol%), and  $\text{PdCl}_2(\text{PPh}_3)_2$  (8.6 mg, 5% mol) in 2.5 mL of  $\text{CH}_3\text{CN}$  was stirred at room temperature under  $\text{N}_2$  for 24 h as monitored by TLC (petroleum ether/ethyl acetate 40:1). Water (10 mL) was added and the reaction mixture was extracted with ether. The combined extracts were washed with saturated  $\text{NaCl}$  and dried over anhydrous  $\text{Na}_2\text{SO}_4$ . Filtration, evaporation, and column chromatography on silica gel (petroleum ether/ethyl acetate 200:1) afforded 53.7 mg (66%) of **3ae** as an oil.

$^1\text{H}$  NMR (400 MHz,  $\text{CDCl}_3$ )  $\delta$  7.61–7.59 (m, 2H), 7.54–7.53 (m, 2H), 7.34–7.33 (m, 6H), 7.11 (s, 1H), 4.11 (s, 2H), 3.59 (q,  $J=6.8$  Hz, 2H), 1.25 (t,  $J=6.8$  Hz, 3H);  $^{13}\text{C}$  NMR (100 MHz,  $\text{CDCl}_3$ )  $\delta$  133.2, 133.0, 131.6, 130.0, 129.3, 128.4, 128.2, 127.7, 122.9, 120.9, 97.1, 86.4, 73.1, 65.8, 15.1; MS (70 eV, EI)  $m/z$  (%): 342 ( $\text{M}^+(\text{}^{80}\text{Se})$ , 100), 340 ( $\text{M}^+(\text{}^{78}\text{Se})$ , 51.49); IR (neat)  $\nu$  ( $\text{cm}^{-1}$ ): 2974, 2866, 2186, 1597, 1094, 755, 690; HRMS calcd for  $\text{C}_{19}\text{H}_{19}\text{O}^{80}\text{Se}^+$  ( $\text{M}^+ + \text{H}$ ): 343.0596. Found: 343.0596.

**3.1.20. Synthesis of (*E*)-3-ethoxy-2-butylpropenyl phenyl selenide (3af).** To a solution of anhydrous  $\text{ZnBr}_2$  (145.4 mg, 0.65 mmol) in 1.5 mL of THF was added dropwise  $n\text{-C}_4\text{H}_9\text{Li}$  (0.18 mL, 2.88 M in hexane) at 0 °C. After stirring for 10 min,  $\text{Pd}(\text{PPh}_3)_4$  (20.2 mg, 8 mol%) and a 1.5 mL of THF solution of 79.0 mg (0.22 mmol) of **2a** were added and the mixture was stirred for 21.5 h as monitored by TLC (petroleum ether/ethyl acetate 40:1). Water (10 mL) was added and the reaction mixture was extracted with ether, washed with saturated  $\text{NaCl}$ , and dried over  $\text{Na}_2\text{SO}_4$ . Filtration, evaporation, and column chromatography on silica gel afforded 39.8 mg (62%) of **3af** as an oil.

$^1\text{H}$  NMR (400 MHz,  $\text{CDCl}_3$ )  $\delta$  7.47 (d,  $J=7.6$  Hz, 2H),

7.28–7.23 (m, 3H), 6.45 (s, 1H), 3.97 (s, 2H), 3.46 (q,  $J=6.8$  Hz, 2H), 2.23 (t,  $J=7.2$  Hz, 2H), 1.47–1.33 (m, 4H), 1.20 (t,  $J=6.8$  Hz, 3H), 0.93 (t,  $J=7.2$  Hz, 3H);  $^{13}\text{C}$  NMR (100 MHz,  $\text{CDCl}_3$ )  $\delta$  142.3, 131.8, 131.2, 129.1, 126.8, 117.5, 73.8, 65.4, 31.7, 30.0, 22.7, 15.1, 14.0; MS (70 eV, EI)  $m/z$  (%): 298 ( $\text{M}^+(\text{}^{80}\text{Se})$ , 53.17), 296 ( $\text{M}^+(\text{}^{78}\text{Se})$ , 26.74), 85 (100); IR (neat)  $\nu$  ( $\text{cm}^{-1}$ ): 2957, 2928, 2858, 1579, 1477, 1438, 1119, 1096, 735, 690; HRMS calcd for  $\text{C}_{15}\text{H}_{23}\text{O}^{80}\text{Se}^+$  ( $\text{M}^+ + \text{H}$ ): 299.0909. Found: 299.0898.

### Acknowledgements

Financial support from the National Natural Science Foundation of China, the Major State Basic Research Development Program (Grant No. G2000077500), and Cheung Kong Scholar Programme is greatly appreciated. Shengming Ma is jointly appointed by Zhejiang University and Shanghai Institute of Organic Chemistry. This work was conducted at Zhejiang University.

### References and notes

- Ma, S. Ionic Additions to Allenes in Modern Allene Chemistry. In Krause, N., Hashmi, A. S. K., Eds.; Wiley-VCH: Weinheim, 2004; pp 595–699.
- Ma, S.; Ren, H.; Wei, Q. *J. Am. Chem. Soc.* **2003**, *125*, 4817–4830.
- Ma, S.; Hao, X.; Huang, X. *Org. Lett.* **2003**, *5*, 1217–1219.
- Ma, S.; Hao, X.; Huang, X. *Chem. Commun.* **2003**, 1082–1083.
- Ma, S.; Hao, X.; Meng, X.; Huang, X. *J. Org. Chem.* **2004**, *69*, 5720–5724.
- Fu, C.; Huang, X.; Ma, S. *Tetrahedron Lett.* **2004**, *45*, 6063–6065.
- Georgoulis, C.; Smadja, W.; Valery, J. M. *Synthesis* **1981**, 572–574.
- (a) Suzuki, A. *Pure Appl. Chem.* **1985**, *57*, 1749–1758. (b) Suzuki, A. *Pure Appl. Chem.* **1991**, *63*, 419–422. (c) Suzuki, A. *Pure Appl. Chem.* **1994**, *66*, 213–222.
- Sonogashira, K. In *Comprehensive Organic Synthesis*, Vol. 3; Pergamon: Oxford, 1990; pp 521–546.
- (a) King, A. O.; Okukado, N.; Negishi, E. *J. Chem. Soc., Chem. Commun.* **1977**, 683–684. (b) Pour, M.; Negishi, E. *Tetrahedron Lett.* **1996**, *37*, 4679–4682. (c) Pour, M.; Negishi, E. *Tetrahedron Lett.* **1997**, *38*, 525–528.

# Stereocontrolled reduction of chiral pyrrolidine and piperidine $\beta$ -enamino esters: formal enantioselective synthesis of (+)-calvine

Sandrine Calvet-Vitale, Corinne Vanucci-Bacqué, Marie-Claude Fargeau-Bellassoued and Gérard Lhommet\*

Laboratoire de Chimie Organique, UMR 7611, Equipe de Chimie des Hétérocycles, Université P. et M. Curie, 4 Place Jussieu, 75252 Paris cedex 05, France

Received 15 March 2005; revised 24 May 2005; accepted 25 May 2005

Available online 15 June 2005

**Abstract**—The results of a study dealing with the chemo- and diastereoselective reduction of chiral pyrrolidine and piperidine  $\beta$ -enamino esters **1**, **2** and **3**, **4** into  $\beta$ -amino esters are reported. This approach was successfully applied to a formal synthesis of (+)-calvine.

© 2005 Elsevier Ltd. All rights reserved.

## 1. Introduction

Diastereoselective synthesis of chiral  $\alpha,\alpha'$ -disubstituted pyrrolidines and piperidines, which are sub-structures present in many naturally occurring and biologically important compounds, is of considerable current interest.<sup>1</sup> In a previous report, we described the diastereoselective preparation of chiral pyrrolidine and piperidine bicyclic  $\beta$ -enamino esters **1**, **2** and **3**, **4** (Fig. 1) by condensation of (*S*)-phenylglycinol on  $\omega$ -oxo alkyanoates or  $\omega$ -oxo  $\beta$ -keto esters.<sup>2</sup> We now wish to report the results of a study aimed at diastereoselectively reducing the double bond of the  $\beta$ -enamino ester moiety of **1–4** in order to obtain the corresponding  $\beta$ -amino esters. Related heterocycles have been indeed already described as useful intermediates in the total synthesis of alkaloids.<sup>1d,3</sup> Finally, as an illustration of the interest of our approach, we will describe a formal synthesis of enantiopure (+)-calvine (**5**).

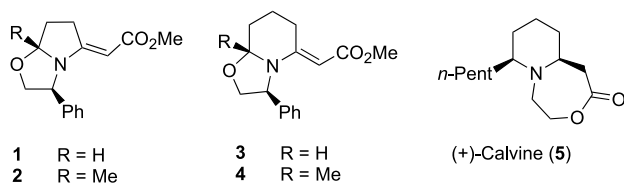


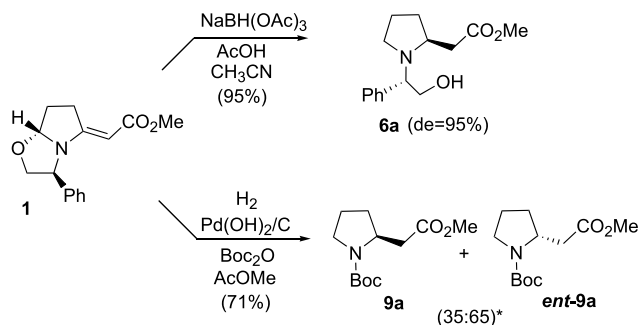
Figure 1.

**Keywords:** Reduction;  $\beta$ -Amino esters; Pyrrolidine; Piperidine; Calvine.  
 \* Corresponding author. Tel.: +33 1 44 27 31 78; fax: +33 1 44 27 30 56; e-mail: lhommet@ccr.jussieu.fr

## 2. Results and discussion

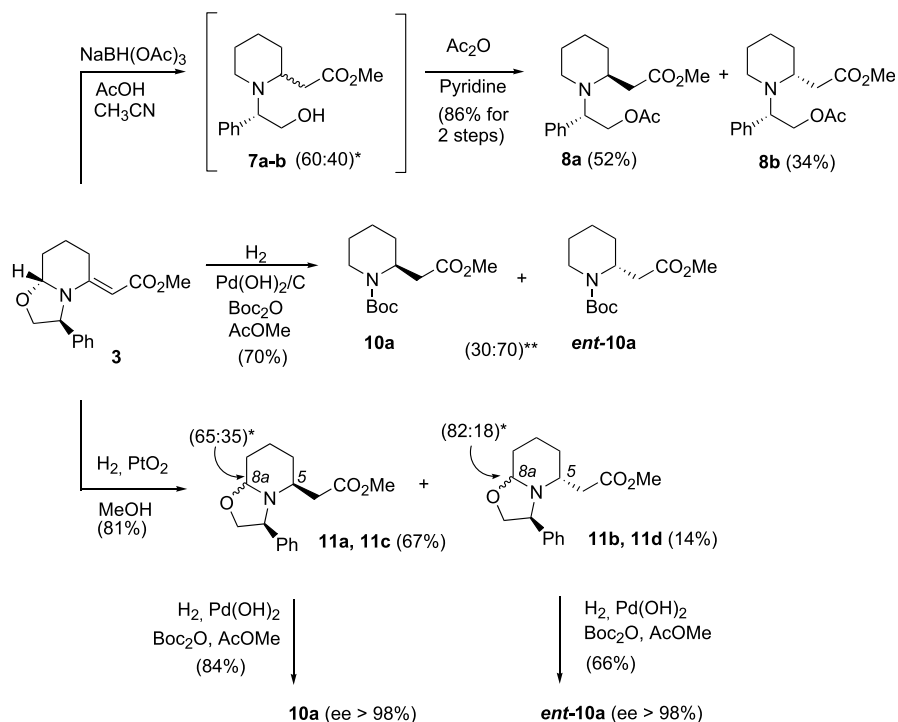
In order to assess the influence of the reducing agent on the chemo- and diastereoselectivity of the reaction, the reductions of  $\beta$ -enamino esters were carried out either by catalytic hydrogenation or using an hydride. Catalytic hydrogenations were performed under atmospheric pressure using  $\text{PtO}_2$  and  $\text{Pd}(\text{OH})_2$  as catalysts, whereas hydride reductions were carried out with sodium triacetoxyborohydride in acetic acid.<sup>4</sup>

We first investigated the reduction of the pyrrolidine and piperidine bicyclic compounds **1** (Scheme 1) and **3** (Scheme 2), which both contain an angular hydrogen atom. Treatment with sodium triacetoxyborohydride of **1** and **3** led to the reduction of the C–C double bond along with the cleavage of the oxazolidine ring to give compounds **6** and **7**, respectively. Pyrrolidine **6** was obtained in high yield (95%)



\*ratio determined by chiral GC analysis

Scheme 1. Reduction of **1**.



\* ratio determined by NMR

\*\* ratio determined by chiral GC analysis

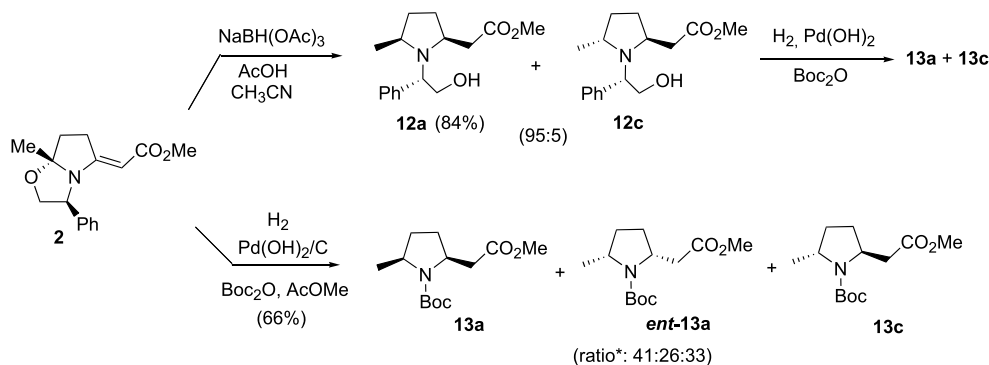
Scheme 2. Reduction of **3**.

and excellent diastereoselectivity (95% de) (Scheme 1). The stereochemistry of the major isomer **6a** was assigned as (2*S*) by comparison of spectroscopic data with that described in the literature.<sup>5</sup> Concerning the piperidine derivative **3** (Scheme 2), the reaction proceeded with poor diastereoselectivity (de=20%) and afforded **7** as an inseparable mixture of diastereomers. The major isomer **7a** was identified as the (2*S*) isomer, since spectroscopic data were found identical to that previously reported for this compound.<sup>5</sup> Acetylation of the crude mixture ( $\text{Ac}_2\text{O}$ , pyridine) resulted in a mixture of two compounds (2*S*)-**8a** and (2*R*)-**8b** that were isolated in 52 and 34% yield, respectively.

Catalytic hydrogenation in the presence of  $\text{Pd(OH)}_2$  and  $\text{Boc}_2\text{O}$  of compounds **1** and **3** was then performed (Schemes 1 and 2). In both cases, *N*-debenzylated  $\beta$ -amino esters were

obtained transiently and in situ transformed into *tert*-butyl carbamates **9** and **10**, respectively, in 71 and 70% isolated yield. Analysis by chiral GC and optical rotation measurements showed that both compounds were obtained with poor stereoselectivity (ee for **9**: 30% and for **10**: 40%) and that the (2*R*) isomers *ent*-**9a**<sup>6</sup> and *ent*-**10a**<sup>3c</sup> were the major enantiomers.

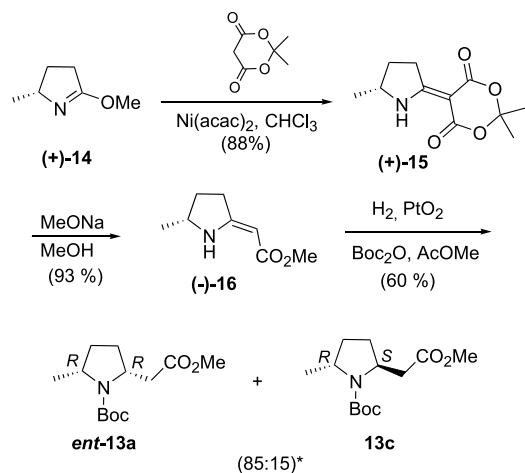
Hydrogenation of compound **1** in the presence of  $\text{PtO}_2$  as the catalyst was surprisingly ineffective.<sup>7</sup> In contrast, under the same reaction conditions, compound **3** was chemoselectively reduced into bicyclic piperidines **11** as a mixture of four isomers (Scheme 2). Column chromatography allowed the isolation of inseparable piperidines **11a**, **11c** (ratio 65:35) on the one hand and of inseparable piperidines **11b**, **11d** (ratio 82:18) on the other hand in, respectively, 67 and 14% yields. In order to secure stereochemistry, each mixture



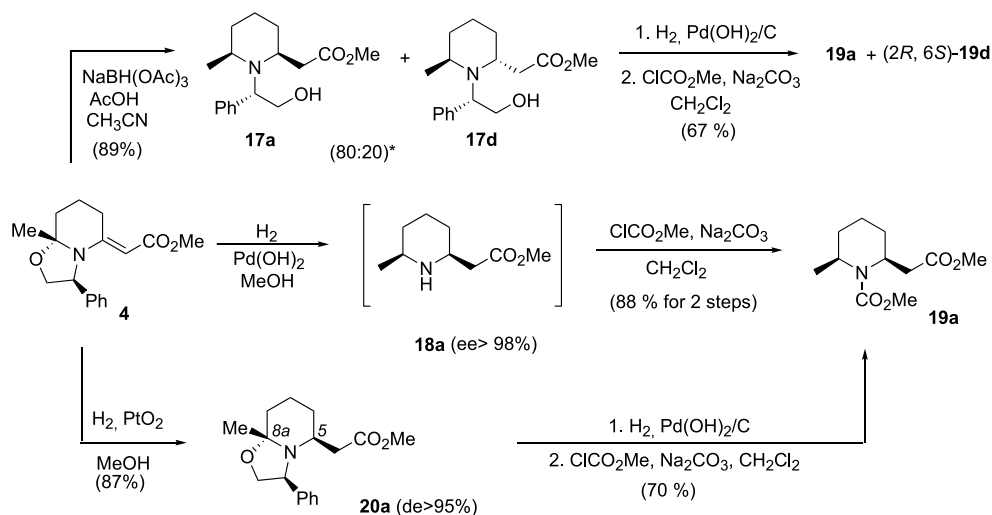
\*determined by chiral GC analysis

Scheme 3. Reduction of **2**.

was submitted to hydrogenolysis in the presence of Pd(OH)<sub>2</sub> and Boc<sub>2</sub>O to yield *N*-*tert*-butoxycarbonyl derivatives **10** in a one-pot procedure. Analysis of the crude mixtures by chiral GC showed in each case the presence of only one isomer, respectively, piperidines **10a** (ee > 98%) and *ent*-**10a** (ee > 98%) (Scheme 2). This result demonstrated that the initial mixtures were composed of epimers at C-8a. NOE experiments conducted on each mixture showed a transfer of saturation from one species to the other, which confirmed that both mixtures of oxazolidines consisted of equilibrated C-8a epimers, as previously observed on related compounds by others.<sup>8</sup> The stereochemistry of the C-8a center is of little importance, since alkylation at C-8a of similar oxazolidines by organometallic or silyl enol ether reagents is known to give selectively *cis* disubstituted piperidines, whatever the initial configuration of the angular carbon.<sup>9</sup> Moreover, comparison of the spectroscopic data of *tert*-butyl carbamate **10a** and *ent*-**10a** with that reported in the literature<sup>3c</sup> demonstrated that absolute configuration at C-5 for **11a** and **11c** was (5*S*) and that for **11b** and **11d** was (5*R*).



Scheme 4.

Scheme 5. Reduction of **4**.

Concerning the angularly substituted bicyclic  $\beta$ -enamino ester **2** (Scheme 3), reduction by sodium triacetoxyborohydride diastereoselectively afforded monocyclic disubstituted pyrrolidine **12**, with an excellent diastereomeric excess (de = 90%), as previously observed for the pyrrolidine analogue **1**. From the crude mixture, compound **12a** was isolated in 84% yield.

Since we were unable to prepare a crystalline salt from **12a** and hence to determine its absolute configuration, we had to rely upon chemical correlation (Scheme 4). With this aim in mind (*S*)-pyroglutamic acid was transformed into the chiral lactim ether **14** according to a previously described procedure.<sup>10</sup> The latter was condensed with Meldrum's acid in the presence of a catalytic amount of Ni(acac)<sub>2</sub> to give in 88% yield  $\beta$ -enamino diester **15**, which in turn underwent successive transesterification and decarboxylation upon heating in a solution of sodium methoxide.<sup>11</sup> Though catalytic hydrogenation of the resulting  $\beta$ -enamino ester **16** had been reported to give stereoselectively the *cis* isomer,<sup>12</sup> in our hands, hydrogenation of **16** in the presence of PtO<sub>2</sub> and Boc<sub>2</sub>O gave the *cis* (2*R*, 5*R*) isomer *ent*-**13a** along with the *trans* (2*S*, 5*R*) isomer **13c** as a 85:15 mixture, in 60% overall yield. On the other hand, crude **12** resulting from the reduction of **2** by NaBH(OAc)<sub>3</sub> was hydrogenolyzed in the presence of Pd(OH)<sub>2</sub> and Boc<sub>2</sub>O to yield a mixture of **13a** and **13c** (Scheme 3). Comparison by chiral GC of the two reaction mixtures allowed us to assign the *cis* stereochemistry and a (2*S*, 5*S*) absolute configuration to the major isomer **12a**, whereas a *trans* (2*S*, 5*R*) configuration was assigned to the minor isomer **12c**.

Compound **2** was then hydrogenated in the presence of Pd(OH)<sub>2</sub> and Boc<sub>2</sub>O. Under these conditions, we obtained, in 66% yield, a disappointing mixture of three isomers, as determined by chiral GC analysis, consisting of a 67:33 mixture of the *cis* isomers ((2*S*, 5*S*)-**13a** and (2*R*, 5*R*)-*ent*-**13a**; (ratio 61:39)) and of the *trans* isomer (2*S*, 5*R*)-**13c** (Scheme 3). Finally, as for compound **1**, hydrogenation of **2** in the presence of PtO<sub>2</sub> left the product unchanged.<sup>7</sup>

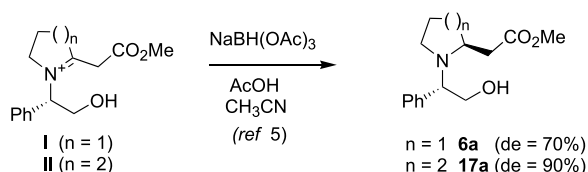
Finally, we turned our attention to the reductions of the angularly substituted piperidine **4** (Scheme 5). Catalytic hydrogenation of this compound in the presence of catalytic Pd(OH)<sub>2</sub> (3 atm, 12 h) followed by reaction with methylchloroformate had previously been reported by Meyers<sup>3b</sup> to afford stereoselectively the *cis* (2*S*, 6*S*) isomer **19a**. We repeated this two-step procedure<sup>13</sup> in order to obtain **19a** as a reference compound of established absolute configuration<sup>3b</sup> (Scheme 5).

On the other hand, the chemical reduction of **4** by NaBH(OAc)<sub>3</sub> afforded monocyclic β-amino ester **17** as a 80:20 mixture of two isomers in 89% overall yield. In order to assign the stereochemistry of these compounds, the mixture was hydrogenolyzed and then reacted with methylchloroformate. Analysis by chiral and achiral GC led us to attribute to the major isomer **17a** the *cis* (2*S*, 6*S*) configuration and the *trans* (2*R*, 6*S*) configuration to the minor isomer **17d**. Finally, PtO<sub>2</sub> catalyzed hydrogenation gave bicyclic piperidine **20a** as a single isomer, in 87% yield. In contrast to what was observed for the hydrogenation of **3**, no epimerization at the quaternary angular carbon had occurred. Hydrogenolysis of **20a** and subsequent methoxycarbonylation led to compound **19a**, which allowed

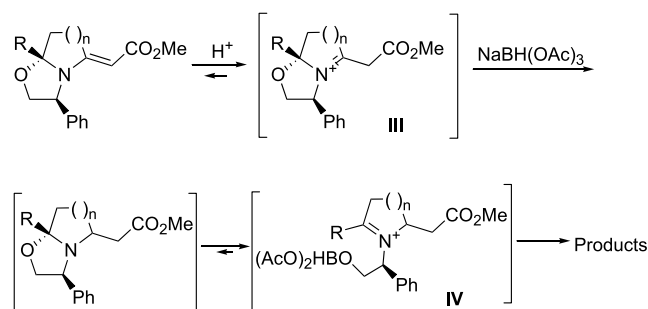
us to assign the (5*S*, 8*aR*) configuration to the oxazolidine **20a**.

Our study clearly showed that bicyclic pyrrolidine and piperidine β-enamino esters displayed different behaviours depending on reduction conditions. Considering that these substrates possess three bonds that may be affected under reductive conditions, diastereoselectivity depends on the timing of the different processes. Efficient reduction of pyrrolidines **1** (Scheme 1) and **2** (Scheme 3) in terms of yield and diastereoselectivity required the use of sodium triacetoxyborohydride under acidic conditions. In contrast, reductions of piperidines **3** (Scheme 2) and **4** (Scheme 5) under similar conditions proceeded with lower diastereoselectivities.

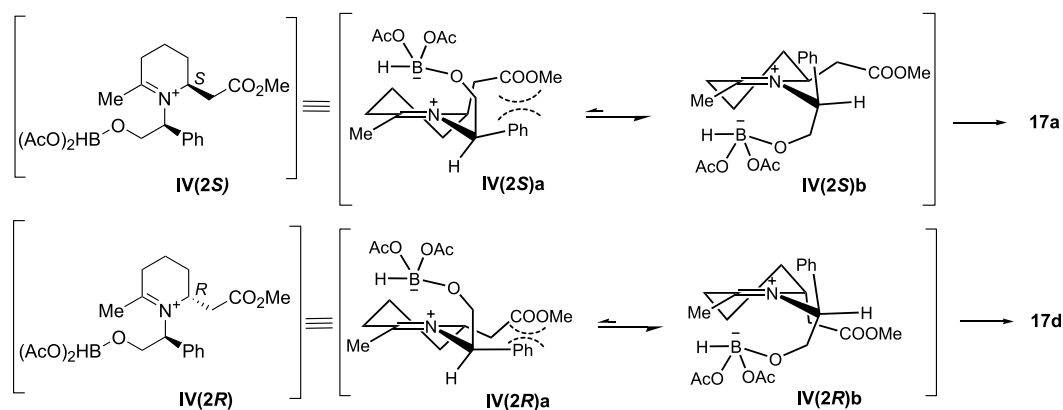
In the case of compounds **1** and **3**, we suppose that the double bond was reduced before the cleavage of the oxazolidine ring, which would explain the observed stereoselectivities (respectively, 95 and 20% diastereomeric excess). Indeed, the presence of the oxazolidine moieties is clearly key in these reductions as substantiated by the comparison with the sodium triacetoxyborohydride-mediated reduction of monocyclic iminium ions **I** and **II** that we previously reported<sup>5</sup> to proceed, respectively, in 70 and 90% diastereomeric excess (Scheme 6).



Scheme 6.



Scheme 7.

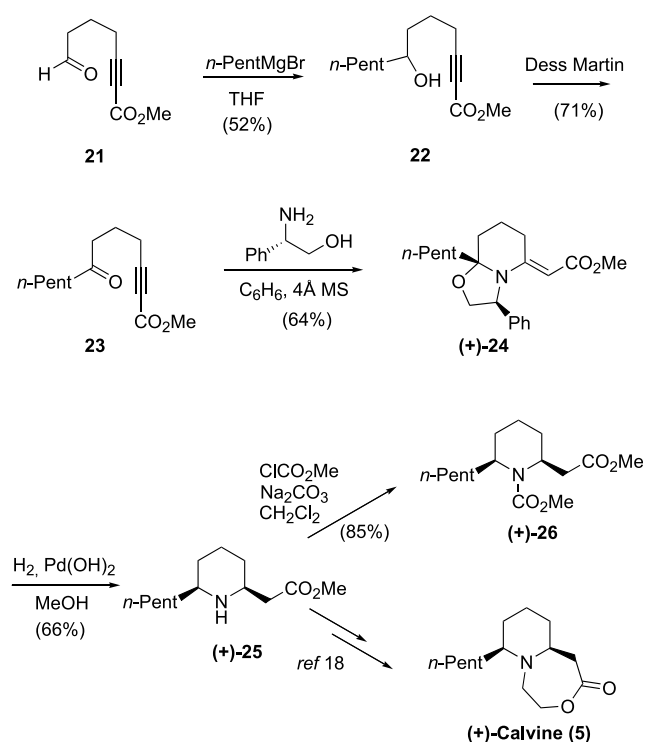
Scheme 8. Proposed mechanism for formation of **17a** and **17d** from piperidine **4**.



and **IV(2R)** whose reactive conformations are depicted in Scheme 8. The observed stereochemistry would result from an axial delivery of the hydride from the favoured conformations **IV(2S)b** and **IV(2R)b** under stereoelectronic control. In comparison, conformations **IV(2S)a** and **IV(2R)a** appear disfavoured due to the strong steric interactions between the phenyl ring of the chiral auxiliary and the C-2 substituent.<sup>17</sup> In the case of conformation **IV(2S)a** whose reduction would lead to an unobserved *trans* (2,6) piperidine, the destabilization induced by the above steric constraints would be able to overcome the benefit arising from the minimization of the A<sup>1,2</sup> allylic strain present in this particular conformation, whereas in conformation **IV(2R)a**, steric factors and allylic strain are additive to disfavour this conformation. Regarding reduction of pyrrolidine **2**, a similar rationale should be considered to account for the major *cis* stereochemistry of the isolated compounds.

As far as catalytic hydrogenations are concerned, these reduction conditions were efficient and selective only in the case of angular methyl-containing oxazolopiperidine **4** (Scheme 5). PtO<sub>2</sub> catalyzed hydrogenation of **4** afforded bicyclic piperidine **20a** with a complete control of the stereochemistry at C-5 as the result of hydrogen attacking *anti* to the phenyl and methyl substituents. Reduction of **4** in the presence of Pd(OH)<sub>2</sub> yielded piperidine **18a** as a single *cis* isomer. This result was assumed to result from the initial reductions of the double and C–O bonds from the *endo* face followed by *N*-debenzylation.<sup>3b</sup> In all other cases (compounds **1**, **2**, and **3**), the poor selectivities observed under these conditions might result from early *N*-debenzylation and/or oxazolidine cleavages, which prevented any stereochemical control during the subsequent reduction of the double bonds. Noteworthy was the (*R*) absolute stereochemistry at C-2 of the major isomers obtained upon hydrogenation of compounds **1** and **3**, a result that contrasts with what was observed in other cases of this study. We have no clear explanation for this result.

In order to illustrate the synthetic potential of our approach, we envisioned to carry out a formal synthesis of (+)-calvine (**5**), a piperidine alkaloid isolated from ladybird beetles of the Genus *Calvia*<sup>18</sup> (Scheme 9). The key step of our strategy relied on the diastereoselective reduction of bicyclic β-enamino ester **24**. The latter was obtained starting from methyl oxo heptynoate **21**<sup>19</sup> in three steps. Addition of *n*-pentylmagnesium bromide to **21** gave alcohol **22**, which was subsequently oxidized to the corresponding ketone **23** according to the Dess–Martin procedure in 71% yield. Condensation of (*S*)-phenylglycinol on compound **23** in refluxing benzene afforded the expected bicyclic oxazolidine **24** in 64% yield, as a single isomer. Catalytic hydrogenation in the presence of Pd(OH)<sub>2</sub> yielded the disubstituted piperidine **25** with an excellent diastereomeric excess (de > 98%) in the favor of the *cis* disubstituted piperidine. Indeed, this compound exhibited NMR data identical with those reported in the literature for the *cis* (2*S*, 6*S*) isomer.<sup>20</sup> However, the measured absolute optical rotation ( $[\alpha]_{\text{D}}^{20} +16$  (*c* 0.64, CHCl<sub>3</sub>)) did not agree with that previously reported<sup>20,21</sup> (lit.<sup>20</sup>  $[\alpha]_{\text{D}}^{20} +23$  (*c* 0.52, CHCl<sub>3</sub>)). In order to secure the enantiomeric excess of (+)-**25**, we synthesized by the same method, the



Scheme 9. Formal synthesis of (+)-calvine.

enantiomer (–)-**25** using (*R*)-phenylglycinol as the chiral inductor ( $[\alpha]_{\text{D}}^{20} -17$  (*c* 1.08, CHCl<sub>3</sub>)). In order to check the optical purity of these compounds by chiral GC, both enantiomers were transformed into their methoxycarbonyl derivatives **26**.<sup>18,20</sup> This allowed us to confirm that each sample consisted of a single enantiomer. This high diastereoselectivity of the reduction of **24** was consistent with that previously observed for the angularly methylated piperidine **4**. Compound **25**, which is also an alkaloid isolated from *Calvia*, is an intermediate previously described in the total synthesis of (+)-calvine.<sup>20</sup>

### 3. Conclusion

In conclusion, the reported study enabled us to prepare enantiopure pyrrolidine and piperidine β-amino esters by chemio- and diastereoselective controlled reductions from bicyclic chiral β-enamino esters. In particular, our strategy gives access to *cis* disubstituted heterocycles that are useful intermediates in the synthesis of alkaloids as illustrated by our formal synthesis of (+)-calvine. Further efforts to develop the synthetic applications of these β-amino esters are underway in our laboratory.

### 4. Experimental

#### 4.1. General

Unless otherwise specified, materials were purchased from commercial suppliers and used without further purification. THF was distilled from sodium/benzophenone ketyl immediately prior to use. CH<sub>2</sub>Cl<sub>2</sub> was distilled from calcium hydride. All reactions were carried out under argon. Thin

layer chromatography analyses were performed on Merck precoated silica gel (60 F<sub>254</sub>) plates and column chromatography on silica gel Gerudan SI 60 (40–60 μm) (Merck). Melting points are uncorrected. IR: Philips PU 9700. Chiral gas chromatographies were performed on a capillary Chrompack CP-Chirasil-DEX CB column and achiral ones on a Chrompack CP-SIL5. Optical rotation: Perkin-Elmer 241 polarimeter. Elemental analysis: Service Régional de Microanalyse de l'Université P. et M. Curie. HMRS were recorded on a JEOL MS 700 mass spectrometer. NMR: Bruker ARX 250 spectrometer (250 and 62.9 MHz for <sup>1</sup>H and <sup>13</sup>C, respectively). Spectra were recorded in CDCl<sub>3</sub> as solvent. Chemical shifts (δ) were expressed in ppm relative to TMS at δ=0 for <sup>1</sup>H and to CDCl<sub>3</sub> at δ=77.1 for <sup>13</sup>C and coupling constants (*J*) in Hertz.

#### 4.2. General procedure for NaBH(OAc)<sub>3</sub> mediated reductions

A solution of NaBH(OAc)<sub>3</sub> was prepared by portionwise addition of NaBH<sub>4</sub> (5 mmol) to glacial acetic acid (25 mol) at 0 °C. After the hydrogen evolution ceased (30 min), a solution of the substrate (1 mmol) in acetonitrile (4 mL) was added. After stirring for 48 h at room temperature, the solvents were evaporated in vacuo. The residue was dissolved in CH<sub>2</sub>Cl<sub>2</sub> and the organic layer was neutralized with saturated aqueous Na<sub>2</sub>CO<sub>3</sub> solution. The organic layer was washed with brine, dried over Na<sub>2</sub>SO<sub>4</sub> and concentrated in vacuo.

**4.2.1. (2*S*)-[1-(2-Hydroxy-1-(*S*)-phenyl-ethyl)-pyrrolidin-2-yl]-acetic acid methyl ester (6a).** The above general procedure was followed for the reduction of compound **1** (312 mg, 1.2 mmol). Purification of the crude product by silica gel column chromatography (cyclohexane/AcOEt 8:2) afforded **6a**<sup>5</sup> (303 mg, 95%) as a solid.

**4.2.2. [1-(2-Acetoxy-1-(*S*)-phenyl-ethyl)-piperidin-2-yl]-acetic acid methyl ester (8).** The general procedure was followed for the reduction of compound **3** (130 mg, 0.5 mmol) to give a 60:40 mixture of (2*S*)-**7b**<sup>5</sup> and (2*R*)-**7b** isomers (132 mg), which were inseparable by silica gel column chromatography. The crude mixture of isomers **7** (132 mg) was stirred overnight in pyridine (9 mL) and acetic anhydride (3 mL). The solvents were evaporated in vacuo and the residue was dissolved in CH<sub>2</sub>Cl<sub>2</sub>. The organic layer was washed with water and brine, dried over Na<sub>2</sub>SO<sub>4</sub> and evaporated in vacuo. Silica gel chromatography (cyclohexane/AcOEt 9:1) allowed the separation of the two isomers (2*S*)-**8a** (79 mg, 52%) and (2*R*)-**8b** (53 mg, 34%) as colorless oils.

For (2*S*)-**8a**.  $[\alpha]_{\text{D}}^{20} +20$  (*c* 1.075, CHCl<sub>3</sub>). IR (neat)  $\nu_{\text{max}}$  1730 cm<sup>-1</sup>. <sup>1</sup>H NMR δ 1.38–1.60 (m, 5H), 1.71–1.77 (m, 1H), 1.98 (s, 3H), 2.36–2.40 (m, 2H), 2.65 (m, AB part of ABX spectrum, 2H, *J*<sub>AB</sub> = 14.25 Hz), 3.45–3.52 (m, 1H), 3.66 (s, 3H), 3.96 (t, 1H, *J* = 6 Hz), 4.38 (m, AB part of ABX spectrum, 2H, *J*<sub>AB</sub> = 11.5 Hz), 7.20–7.36 (m, 5H). <sup>13</sup>C NMR δ 20.7, 20.9, 25.6, 29.9, 32.5, 44.9, 51.5, 53.4, 62.7, 65.1, 127.3, 128.0, 128.3, 141.0, 170.8, 173.2. Anal. Calcd for C<sub>18</sub>H<sub>25</sub>NO<sub>4</sub>: C, 67.69; H, 7.89; N, 4.39. Found: C, 67.45; H, 7.95; N, 4.11.

For (2*R*)-**8b**.  $[\alpha]_{\text{D}}^{20} +18$  (*c* 0.5, CHCl<sub>3</sub>). IR (neat)  $\nu_{\text{max}}$  1740 cm<sup>-1</sup>. <sup>1</sup>H NMR δ 1.37–1.72 (m, 6H), 1.98 (s, 3H), 2.37–2.52 (m, 2H), 2.62–2.77 (m, 2H), 3.10–3.15 (m, 1H), 3.63 (s, 3H), 4.05 (t, 1H, *J* = 6.25 Hz), 4.34 (m, AB part of ABX spectrum, 2H, *J*<sub>AB</sub> = 11.5 Hz), 7.23–7.35 (m, 5H). <sup>13</sup>C NMR δ 20.8, 21.0, 25.0, 29.6, 34.2, 44.8, 51.5, 53.3, 62.6, 66.0, 127.5, 128.3 (2C), 139.0, 170.8, 173.1.

#### 4.2.3. (2*S*, 5*S*)-[1-(Hydroxy-1-(*S*)-phenyl-ethyl)-5-methyl-pyrrolidin-2-yl]-acetic acid methyl ester (12a).

The general procedure was followed for the reduction of compound **2** (312 mg, 1.14 mmol). Purification of the crude product by silica gel column chromatography (cyclohexane/AcOEt 8:2) afforded **12a** (266 mg, 84%) as an oil:  $[\alpha]_{\text{D}}^{25} +23$  (*c* 0.98, CHCl<sub>3</sub>). IR (neat)  $\nu_{\text{max}}$  3400, 1730 cm<sup>-1</sup>. <sup>1</sup>H NMR 1.2 (d, 3H, *J* = 6 Hz), 1.31–1.48 (m, 3H), 1.70–1.77 (m, 1H), 2.41 (m, AB part of ABX spectrum, 2H, *J*<sub>AB</sub> = 14.25 Hz), 3.07–3.15 (m, 1H), 3.27 (br s, 1H), 3.47–3.54 (m, 1H), 3.66 (s, 3H), 3.59–3.73 (m, 1H), 3.83–3.96 (m, 2H), 7.21–7.38 (m, 5H). <sup>13</sup>C NMR δ 21.0, 30.3, 32.0, 43.1, 51.4, 54.3, 58.3, 61.6, 63.4, 127.7, 128.2, 128.7, 136.7, 172.5. Anal. Calcd for C<sub>16</sub>H<sub>23</sub>NO<sub>3</sub>: C, 69.29; H, 8.36; N, 5.05. Found: C, 69.27; H, 8.23; N, 5.07.

#### 4.2.4. (6*S*)-[1-(2-Hydroxy-1-(*S*)-phenyl-ethyl)-6-methyl-piperidin-2-yl]-acetic acid methyl ester (17).

The general procedure was followed for the reduction of compound **4** (161 mg, 0.5 mmol). Purification of the crude product by silica gel column chromatography (cyclohexane/AcOEt 8:2) afforded **17** (146 mg, 89%) as an inseparable oily 8:2 mixture of isomers. IR (neat)  $\nu_{\text{max}}$  3440, 1735 cm<sup>-1</sup>. For major (2*S*,6*S*)-**17a**. <sup>1</sup>H NMR δ 1.02 (d, 3H, *J* = 6.75 Hz), 1.28–1.61 (m, 6H), 1.93 (br s, 1H), 2.56 (m, AB part of ABX spectrum, 2H, *J*<sub>AB</sub> = 14.5 Hz), 2.93–3.07 (m, 1H), 3.55–3.68 (m, 1H), 3.70 (s, 3H), 3.69–3.74 (m, 1H), 3.85–3.92 (m, 2H), 7.28–7.35 (m, 5H). <sup>13</sup>C NMR δ 14.7, 19.0, 27.7, 30.4, 38.6, 49.8, 49.9, 51.6, 62.5, 66.3, 127.5, 128.4, 129.0, 140.1, 173.4. For minor (2*R*,6*S*)-**17d**. <sup>1</sup>H NMR (only the more significant signals are reported) δ 1.29 (d, 3H, *J* = 7 Hz), 3.73 (s, 3H). <sup>13</sup>C NMR δ 20.3, 20.9, 26.1, 30.6, 37.7, 49.3, 49.6, 51.7, 59.1, 60.7, 127.9, 128.3, 129.1, 140.9, 173.1. HRMS (CI) calcd *m/z* for C<sub>17</sub>H<sub>26</sub>NO<sub>3</sub> (MH<sup>+</sup>): 292.1913. Found: 292.1907.

#### 4.3. General procedure for Pd(OH)<sub>2</sub> catalyzed hydrogenation and in situ carbamatation by Boc<sub>2</sub>O

A solution of the substrate (1 mmol) in methyl acetate (40 mL) was subjected to hydrogenation (1 atm) in the presence of Pd(OH)<sub>2</sub>/C (0.5 equiv in weight) and Boc<sub>2</sub>O (2.1 equiv), at room temperature. The progress of the reaction was monitored by GC. The reaction mixture was filtered, the residue thoroughly washed with MeOH and the combined filtrates were concentrated in vacuo.

**4.3.1. 2-Methoxycarbonylmethyl-pyrrolidine-1-carboxylic acid *tert*-butyl ester (9).** The general procedure was followed for the reduction of compound **1** (42 mg, 0.16 mmol). Purification of the crude product by silica gel column chromatography (cyclohexane/AcOEt 8:2) afforded **9**<sup>6</sup> (28 mg, 71%) as an oily mixture of enantiomers.

**4.3.2. 2-Methoxycarbonylmethyl-piperidin-1-carboxylic acid *tert*-butyl ester (10).** The general procedure was followed for the reduction of compound **3** (94 mg, 0.34 mmol). Purification of the crude product by silica gel column chromatography (cyclohexane/AcOEt 8:2) afforded **10**<sup>3c</sup> (62 mg, 70%) as an oily mixture of enantiomers.

**4.3.3. 2-Methoxycarbonylmethyl-5-methyl-pyrrolidine-1-carboxylic acid *tert*-butyl ester (13).** From crude **12**. The general procedure was followed for the reduction of compound **12** (51 mg, 0.18 mmol). Purification of the crude product by silica gel column chromatography (cyclohexane/AcOEt 85:15) afforded an inseparable 95:5 mixture **13a** and **13c** (44 mg, 94%) as an oil. For (2*S*,5*S*)-**13a** (from the mixture). IR (neat)  $\nu_{\max}$  1725, 1690  $\text{cm}^{-1}$ . <sup>1</sup>H NMR  $\delta$  1.18 (d, 3H,  $J=6$  Hz), 1.44 (s, 9H), 1.51–1.55 (m, 1H), 1.67–1.74 (m, 1H), 1.92–2.05 (m, 2H), 2.30 (dd, 1H,  $J=9.5$ , 15 Hz), 2.75–3.05 (m, 1H), 3.65 (s, 3H), 3.75–3.90 (m, 1H), 4.05–4.15 (m, 1H). <sup>13</sup>C NMR  $\delta$  21.8, 28.5, 29.7, 31.5, 40.3, 51.5, 54.1, 55.4, 79.3, 154.5, 172.0. HRMS (CI) calcd  $m/z$  for C<sub>13</sub>H<sub>24</sub>NO<sub>4</sub> (MH<sup>+</sup>): 256.1705. Found: 256.1706.

From compound **2**. The general procedure was followed for the reduction of compound **2** (111 mg, 0.4 mmol). Purification of the crude product by silica gel column chromatography (cyclohexane/AcOEt 85:15) afforded **13a**, *ent*-**13a** and **13c** (69 mg, 66%) as an inseparable oily mixture of isomers.

From compound **16**. The general procedure was followed for the reduction of compound **16** (233 mg, 1.5 mmol) using PtO<sub>2</sub> (50 mg) in the place of Pd(OH)<sub>2</sub>. The crude product was chromatographed on silica gel (cyclohexane/AcOEt 85:15) to give an inseparable 85:15 mixture of *ent*-**13a** and **13c** (231 mg, 60%).

**4.3.4. 2-Methoxycarbonylmethyl-6-methyl-piperidin-1-carboxylic acid methyl ester (19a).** A solution of **4** (107 mg, 0.37 mmol) dissolved in MeOH (10 mL) was subjected to hydrogenation (1 atm) in the presence of Pd(OH)<sub>2</sub>/C (53 mg) at room temperature for 12 h. The reaction mixture was filtered and the residue washed with MeOH. Concentration in vacuo afforded a crude oil, which was dissolved in CH<sub>2</sub>Cl<sub>2</sub> (8 mL). To the ice-cooled solution was added a 0.4 M aqueous solution of Na<sub>2</sub>CO<sub>3</sub> (1.85 mL). Methylchloroformate (53 mg, 0.56 mmol) dissolved in CH<sub>2</sub>Cl<sub>2</sub> (1 mL) was added dropwise, and the reaction mixture was stirred at room temperature overnight. CH<sub>2</sub>Cl<sub>2</sub> was added (15 mL) and the organic layer was successively washed with water (3 × 10 mL) and brine (10 mL). The combined organic layer was dried over Na<sub>2</sub>SO<sub>4</sub> and concentrated in vacuo. Silica gel column chromatography (cyclohexane/AcOEt 7:3) afforded compound **19a**<sup>3b</sup> (75 mg, 88%) as an oil:  $[\alpha]_{\text{D}}^{20} +44$  ( $c$  0.85, CHCl<sub>3</sub>) (lit.<sup>3b</sup>  $[\alpha]_{\text{D}}^{20} +41$  ( $c$  1.16, CHCl<sub>3</sub>)).

#### 4.4. General procedure for PtO<sub>2</sub> catalyzed hydrogenation

A solution of the substrate (1 mmol) dissolved in MeOH (30 mL) was subjected to hydrogenation (1 atm) in the presence of PtO<sub>2</sub> (0.25 equiv in weight) at room temperature for 24 h. The reaction mixture was filtered, the residue

thoroughly washed with MeOH and the organic layer was concentrated in vacuo.

**4.4.1. (3-Phenyl-hexahydro-oxazolo[3,2-*a*]pyridine-5-yl)-acetic acid methyl ester (11).** The general procedure was followed for the reduction of compound **3** (158 mg, 0.58 mmol) to give a 85:15 mixture of isomers **11a**, **11c** and **11b**, **11d**. Purification of the crude product by silica gel column chromatography (cyclohexane/AcOEt 8:2) allowed the isolation of (5*S*)-**11a**,**11c** (107 mg, 67%) as an oily 65:35 mixture of epimers at C-8a and (5*R*)-**11b**,**11d** (23 mg, 14%) as 82:18 mixture of epimers at C-8a. IR (neat)  $\nu_{\max}$  1735  $\text{cm}^{-1}$ .

For major isomer of **11a**, **11c**. <sup>1</sup>H NMR  $\delta$  1.26–1.48 (m, 2H), 1.51, 1.67 (m, 2H), 1.78–1.88 (m, 2H), 2.0–2.10 (m, 1H), 2.19–2.28 (m, 1H), 2.84–2.92 (m, 1H), 3.49 (s, 3H), 3.57–3.63 (m, 1H), 3.75–3.84 (m, 2H), 4.13–4.19 (m, 1H), 7.22–7.40 (m, 5H). <sup>13</sup>C NMR  $\delta$  22.2, 30.0, 32.4, 40.5, 51.4, 57.9, 65.4, 74.6, 95.6, 126.6, 127.3, 128.6, 143.5, 172.4. For minor isomer of **11a**, **11c**. <sup>1</sup>H NMR  $\delta$  1.26–1.66 (m, 3H), 1.77–1.85 (m, 2H), 2.0–2.1 (m, 1H), 2.48 (m, AB part of ABX spectrum, 2H,  $J_{\text{AB}}=15.25$  Hz), 2.98–3.06 (m, 1H), 3.62 (s, 3H), 3.67–3.71 (m, 1H), 4.34–4.44 (m, 2H), 4.49 (t, 1H,  $J=3$  Hz), 7.22–7.40 (m, 5H). <sup>13</sup>C NMR  $\delta$  17.9, 26.9, 30.6, 41.4, 51.4, 55.1, 66.1, 70.0, 89.1, 127.0, 127.5, 128.6, 142.5, 172.5. HRMS (CI) calcd  $m/z$  for C<sub>16</sub>H<sub>22</sub>NO<sub>3</sub> (MH<sup>+</sup>): 276.1600. Found: 276.1598.

For major isomer of **11b**, **11d**. <sup>1</sup>H NMR  $\delta$  1.47–1.78 (m, 5H), 2.0–2.1 (m, 1H), 2.47 (m, AB part of ABX spectrum, 2H,  $J_{\text{AB}}=14.25$  Hz), 3.44–3.50 (m, 1H), 3.57 (s, 3H), 3.60–3.66 (m, 1H), 3.88–4.00 (m, 1H), 4.10–4.22 (m, 2H), 7.22–7.38 (m, 5H). <sup>13</sup>C NMR  $\delta$  17.9, 28.8, 29.1, 31.5, 49.7, 51.7, 61.6, 73.4, 87.5, 127.8, 127.9, 128.7, 138.9, 173.1. For minor isomer of **11b**, **11d** (only the more significant signals are reported). <sup>1</sup>H NMR  $\delta$  2.70 (m, 1H), 4.38–4.59 (m, 4H).

**4.4.2. (5*S*, 8*aR*)-(8*a*-Methyl-3-phenyl-hexahydro-oxazolo[3,2-*a*]pyridine-5-yl)-acetic acid methyl ester (20a).** The general procedure was followed for the reduction of compound **4** (215 mg, 0.75 mmol). Purification of the crude product by silica gel column chromatography (cyclohexane/AcOEt 8:2) afforded **20a** (188 mg, 87%) as an oil:  $[\alpha]_{\text{D}}^{20} +99$  ( $c$  1.225, CHCl<sub>3</sub>). IR (neat)  $\nu_{\max}$  1730  $\text{cm}^{-1}$ . <sup>1</sup>H NMR  $\delta$  1.39 (s, 3H), 1.55–1.86 (m, 6H), 2.42 (m, AB part of ABX spectrum, 2H,  $J_{\text{AB}}=15$  Hz), 3.20–3.30 (m, 1H), 3.52 (s, 3H), 3.66–3.73 (m, 1H), 4.20–4.30 (m, 2H), 7.25–7.38 (m, 5H). <sup>13</sup>C NMR  $\delta$  17.7, 25.6, 27.9, 32.8, 41.1, 51.4, 53.6, 67.5, 71.1, 94.2, 127.2, 127.4, 128.4, 142.4, 172.4. Anal. Calcd for C<sub>17</sub>H<sub>23</sub>NO<sub>3</sub>: C, 70.56; H, 8.01; N, 4.84. Found: C, 70.33; H, 7.89; N, 4.79.

**4.4.3. (5*R*)-2,2-Dimethyl-5-pyrrolidin-2-ylidene-[1,3]dioxane-4,6-dione (15).** To a solution of lactim ether **14** (2.26 g, 20 mmol) in CHCl<sub>3</sub> (30 mL) was added Meldrum's acid (2.88 g, 20 mmol) and Ni(acac)<sub>2</sub> (10 mg). The reaction mixture was stirred at reflux temperature overnight. The solvent was removed in vacuo and the crude product crystallized in EtOH to afford the expected compound **15**<sup>22</sup> (3.97 g, 88%), as a solid. Mp = 150 °C:  $[\alpha]_{\text{D}}^{28} +26$  ( $c$  1.08, CHCl<sub>3</sub>). IR (neat)  $\nu_{\max}$  3270, 1690, 1640, 1590  $\text{cm}^{-1}$ . <sup>1</sup>H NMR  $\delta$  1.35 (d, 3H,  $J=6.5$  Hz), 1.69 (s, 3H), 1.71 (s, 3H),

2.27–2.41 (m, 1H), 3.20–3.34 (m, 1H), 3.47–3.60 (m, 1H), 4.06–4.20 (m, 1H), 10 (br s, 1H).  $^{13}\text{C}$  NMR  $\delta$  21.2, 26.6, 26.7, 29.1, 34.8, 56.8, 81.3, 103.1, 163.1, 166.4, 175.9.

**4.4.4. (5R)-Pyrrolidin-2-ylidene-acetic acid methyl ester (16).** A solution of compound **15** (2 g, 8.8 mmol) and sodium methylate (8.8 mmol) in MeOH (50 mL) was refluxed for 12 h. The cooled reaction mixture was concentrated in vacuo and the residue dissolved in water (40 mL). The solution was neutralized to pH=6 by addition of a chilled 1 N HCl aqueous solution. The aqueous layer was extracted with  $\text{CHCl}_3$  ( $3 \times 50$  mL), the combined organic layer was dried over  $\text{Na}_2\text{SO}_4$ . Concentration in vacuo gave **16** (1.23 g, 93%), which was pure enough to be used in the next step without further purification. Chromatography on silica gel (cyclohexane/AcOEt 80:20) afforded an analytical sample of **16** as an oil:  $[\alpha]_{\text{D}}^{29} -11$  (c 1.315,  $\text{CHCl}_3$ ). IR (neat)  $\nu_{\text{max}}$  3350, 1655, 1600  $\text{cm}^{-1}$ .  $^1\text{H}$  NMR  $\delta$  1.23 (d, 3H,  $J=6.25$  Hz), 1.44–1.58 (m, 1H), 2.06–2.18 (m, 1H), 2.56–2.67 (m, 2H), 3.64 (s, 3H), 3.89 (sext, 1H,  $J=6.5$  Hz), 4.48 (s, 1H), 7.9 (br s, 1H).  $^{13}\text{C}$  NMR  $\delta$  21.2, 29.9, 31.8, 49.5, 54.7, 75.6, 165.5, 170.6. Anal. Calcd for  $\text{C}_8\text{H}_{13}\text{NO}_2$ : C, 61.91; H, 8.44; N, 9.03. Found: C, 61.60; H, 8.51; N, 9.10.

**4.4.5. 7-Hydroxy-dodec-2-ynoic acid methyl ester (22).** To a solution of compound **21**<sup>19</sup> (1.75 g, 11.35 mmol) in anhydrous  $\text{Et}_2\text{O}$  (50 mL), cooled at  $-78^\circ\text{C}$ , was added dropwise a 2 M solution of *n*-PentMgBr in  $\text{Et}_2\text{O}$  (6.8 mL, 13.6 mmol). The reaction mixture was allowed to warm to  $-5^\circ\text{C}$  over 3.5 h and then quenched with aqueous saturated  $\text{NH}_4\text{Cl}$  solution (20 mL). The aqueous layer was extracted with  $\text{Et}_2\text{O}$  ( $3 \times 40$  mL). The organic layers were combined and then washed with brine (30 mL) and dried over  $\text{Na}_2\text{SO}_4$ . Concentration in vacuo gave a crude product, which was purified by silica gel column chromatography (cyclohexane/AcOEt 8:2) to give compound **22** (1.33 g, 52%), as a colorless oil. IR (neat)  $\nu_{\text{max}}$  1730, 2260, 3430  $\text{cm}^{-1}$ .  $^1\text{H}$  NMR  $\delta$  0.90 (t, 3H,  $J=6.5$  Hz), 1.31–1.65 (m, 13H), 2.39 (t, 2H,  $J=7$  Hz), 3.55–3.70 (m, 1H), 3.77 (s, 3H).  $^{13}\text{C}$  NMR  $\delta$  14.0, 18.6, 22.6, 23.7, 25.3, 31.3, 36.3, 37.5, 52.6, 71.2, 73.0, 89.6, 154.2. Anal. Calcd for  $\text{C}_{13}\text{H}_{22}\text{O}_3$ : C, 68.99; H, 9.80. Found: C, 68.81; H, 9.88.

**4.4.6. 7-Oxo-dodec-2-ynoic acid methyl ester (23).** To a solution of alcohol **22** (1 g, 4.42 mmol) in  $\text{CH}_2\text{Cl}_2$  (20 mL) was added a Dess–Martin periodinane solution in  $\text{CH}_2\text{Cl}_2$  (15% in weight, 17 g, 6 mmol). The reaction mixture was stirred at room temperature for 3 h. To the reaction mixture were successively added  $\text{Et}_2\text{O}$  (30 mL), an aqueous saturated  $\text{NaHCO}_3$  solution (45 mL) and sodium thiosulfate (3 g). The aqueous layer was extracted with  $\text{Et}_2\text{O}$  ( $3 \times 30$  mL). The combined organic layers were washed with a saturated  $\text{NaHCO}_3$  solution (30 mL) and then brine (30 mL) before drying over  $\text{Na}_2\text{SO}_4$  and concentrating in vacuo. Silica gel column chromatography (cyclohexane/AcOEt 90:10) gave pure **23** (0.7 g, 71%) as a colorless oil. IR (neat)  $\nu_{\text{max}}$  1720, 1735, 2270  $\text{cm}^{-1}$ .  $^1\text{H}$  NMR  $\delta$  0.89 (t, 3H,  $J=7$  Hz), 1.24–1.36 (m, 4H), 1.58 (quint, 2H,  $J=7$  Hz), 1.85 (quint, 2H,  $J=7$  Hz), 2.37–2.44 (m, 4H), 2.56 (t, 2H,  $J=7$  Hz), 3.74 (s, 3H).  $^{13}\text{C}$  NMR  $\delta$  13.6, 17.6, 21.1, 22.2, 23.3, 31.1, 40.5, 42.6, 52.2, 73.2, 88.4, 153.7, 209.7. Anal. Calcd for  $\text{C}_{13}\text{H}_{20}\text{O}_3$ : C, 69.61; H, 8.99. Found: C, 69.93; H, 9.22.

**4.4.7. (8aR)-(8a-Pentyl-3-phenyl-hexahydro-oxazolo[3,2-a]pyridine-5-ylidene)-acetic acid methyl ester (24).**

A solution of ketone **23** (400 mg, 1.78 mmol) and (*S*)-phenylglycinol (294 mg, 2.94 mmol) in benzene (20 mL) in the presence of 4 Å molecular sieves (5 g), was refluxed for 24 h. The reaction mixture was cooled to room temperature, filtered and the solvent removed in vacuo. Silica gel column chromatography of the residue (cyclohexane/AcOEt 85:15) afforded pure **24** (390 mg, 64%) as a colorless oil:  $[\alpha]_{\text{D}}^{20} +161$  (c 0.375,  $\text{CHCl}_3$ ). IR (neat)  $\nu_{\text{max}}$  1720  $\text{cm}^{-1}$ .  $^1\text{H}$  NMR  $\delta$  0.87 (t, 3H,  $J=6.5$  Hz), 1.24–1.86 (m, 11H), 2.27–2.34 (m, 1H), 2.68–2.77 (m, 1H), 3.49 (s, 3H), 3.65–3.78 (m, 2H), 4.33 (s, 1H), 4.46 (t, 1H,  $J=8.5$  Hz), 4.75 (t, 1H,  $J=8.5$  Hz), 7.15–7.39 (m, 5H).  $^{13}\text{C}$  NMR  $\delta$  13.9, 16.1, 22.6, 24.0, 24.4, 31.1, 31.9, 35.1, 49.9, 62.5, 70.2, 86.0, 96.1, 125.4, 127.5, 128.9, 138.8, 159.4, 169.0. HRMS (CI) calcd *m/z* for  $\text{C}_{21}\text{H}_{30}\text{NO}_3$  ( $\text{MH}^+$ ): 344.2226. Found: 344.2225.

**4.4.8. (2S, 6S)-(6-Pentyl-piperidin-2-yl)-acetic acid methyl ester (25).**

A solution of compound **25** (0.47 g, 1.37 mmol) dissolved in MeOH (25 mL) was subjected to hydrogenation (1 atm) in the presence of  $\text{Pd}(\text{OH})_2$  (94 mg), at room temperature for 6 h. The reaction mixture was filtered over a Celite<sup>®</sup> pad, the residue thoroughly washed with MeOH and the solvent removed in vacuo. The residue was dissolved in 1 N NaOH aqueous solution (10 mL) then extracted with  $\text{CH}_2\text{Cl}_2$ . The organic layer was washed with brine and water, dried over  $\text{Na}_2\text{SO}_4$  and concentrated in vacuo. Silica gel column chromatography of the residue (eluted with AcOEt/MeOH 9:1) afforded pure piperidine **25**<sup>20</sup> (203 mg, 66%):  $[\alpha]_{\text{D}}^{20} +16$  (c 0.64,  $\text{CHCl}_3$ ).

**4.4.9. (2S, 6S)-2-Methoxycarbonylmethyl-6-pentyl-piperidine-1-carboxylic acid methyl ester (26).**

To an ice-cooled solution of **25** (57 mg, 0.25 mmol) in  $\text{CH}_2\text{Cl}_2$  (5 mL) was added a 0.4 M aqueous solution of  $\text{Na}_2\text{CO}_3$  (1.25 mL). Methylchloroformate (0.1 mL, 1.3 mmol) was added dropwise, and the reaction mixture was stirred at room temperature overnight.  $\text{CH}_2\text{Cl}_2$  was added (15 mL) and the organic layer was successively washed with water ( $3 \times 10$  mL) and brine (10 mL). The combined organic layer was dried over  $\text{Na}_2\text{SO}_4$  and concentrated in vacuo. Silica gel column chromatography (cyclohexane/AcOEt 85:15) afforded compound **26**<sup>18,20</sup> (60 mg, 85%) as an oil:  $[\alpha]_{\text{D}}^{20} +24$  (c 0.985,  $\text{CHCl}_3$ ).

## References and notes

- (a) Daly, J. W.; Garraffo, H. M.; Spande, I. F. Alkaloids from amphibian skins; In *Alkaloids: Chemical and Biochemical Perspectives*; Pelletier, S. W., Ed. Pergamon: Oxford, 1999; Vol. 13, 1, pp 2–161. (b) Bailey, P. D.; Millwood, P. A.; Smith, P. D. *Chem. Commun.* **1998**, 633–640. (c) Katritzky, A. R.; Qiu, G.; Yang, B.; Steel, P. J. *J. Org. Chem.* **1998**, *63*, 6699–6703. (d) Momose, T.; Toshima, M.; Seki, S.; Koike, Y.; Toyooka, N.; Hirai, Y. *J. Chem. Soc., Perkin Trans. 1* **1997**, 1315–1321. (e) Amat, M.; Llor, N.; Hidalgo, J.; Escolano, C.; Bosch, J. *J. Org. Chem.* **2003**, *68*, 1919–1928.
- David, O.; Calvet, S.; Chau, F.; Vanucci-Bacqué, C.; Fargeau-

- Bellassoued, M.-C.; Lhommet, G. *J. Org. Chem.* **2004**, *69*, 2888–2891.
- (a) Back, T. G.; Hamilton, M. D. *Org. Lett.* **2002**, *4*, 1779–1781. (b) Munchhof, M. J.; Meyers, A. I. *J. Am. Chem. Soc.* **1995**, *117*, 5399–5400. (c) Morley, C.; Knight, D. W.; Share, A. C. *J. Chem. Soc., Perkin Trans. 1* **1994**, 2903–2907. (d) Ledoux, S.; Marchalant, E.; Célérier, J.-P.; Lhommet, G. *Tetrahedron Lett.* **2001**, *42*, 5397–5399. (e) Bardou, A.; Célérier, J.-P.; Lhommet, G. *Tetrahedron Lett.* **1998**, *39*, 5189–5192.
  - Cimarelli, C.; Palmieri, G. *J. Org. Chem.* **1996**, *61*, 5557–5563.
  - Calvet, S.; David, O.; Vanucci-Bacqué, C.; Fargeau-Bellassoued, M.-C.; Lhommet, G. *Tetrahedron* **2003**, *59*, 6333–6339.
  - Harrison, J. R.; O'Brien, P.; Porter, D. W.; Smith, N. M. *J. Chem. Soc., Perkin Trans. 1* **1999**, 3623–3631.
  - The use of Pt/C and Pd/C as catalysts equally met with failure.
  - Wong, Y.-S.; Marazano, C.; Gnecco, D.; Génisson, Y.; Chiaroni, A.; Das, B. C. *J. Org. Chem.* **1997**, *62*, 729–733.
  - (a) Poerwono, H.; Higashiyama, K.; Yamauchi, T.; Kubo, H.; Ohmiya, S.; Takahashi, H. *Tetrahedron* **1998**, *54*, 13955–13970. (b) Berrien, J.-F.; Billion, M.-A.; Husson, H.-P.; Royer, J. *J. Org. Chem.* **1995**, *60*, 2922–2924.
  - Provot, O.; Célérier, J.-P.; Petit, H.; Lhommet, G. *J. Org. Chem.* **1992**, *57*, 2163–2166.
  - Célérier, J.-P.; Deloisy-Marchalant, E.; Lhommet, G.; Maitte, P. *Org. Synth.* **1988**, *67*, 170–175.
  - Vo Thanh, G.; Célérier, J.-P.; Fleurant, A.; Grandjean, C.; Rosset, S.; Lhommet, G. *Heterocycles* **1996**, *43*, 1381–1384.
  - The reaction in the presence of Pd(OH)<sub>2</sub> was performed under 1 atm of hydrogen contrary to Ref. 3b. It is of note that the use of Pd/C and Pt/C as catalysts gave rise to the same results with an excellent diastereoselectivity in the favor of the (2*S*, 6*S*) single isomer **18a**.
  - The same result in favor of the *cis* 2,6-disubstituted isomer was previously observed during the reductive cleavage of the oxazolidine ring of bicyclic angularly substituted piperidine with NaBH<sub>4</sub> in THF containing TFA.<sup>15</sup>
  - Grierson, D. S.; Royer, J.; Guerrier, L.; Husson, H.-P. *J. Org. Chem.* **1986**, *51*, 4475–4477.
  - Palmieri, G. *Eur. J. Org. Chem.* **1999**, 805–811.
  - Fréville, S.; Bonin, M.; Célérier, J.-P.; Husson, H.-P.; Lhommet, G.; Quirion, J.-C.; Thuy, V. M. *Tetrahedron* **1997**, *53*, 8447–8456.
  - Braekman, J.-C.; Charlier, A.; Daloze, D.; Heilporn, S.; Pasteels, J.; Plasman, V.; Wang, S. *Eur. J. Org. Chem.* **1999**, 1749–1755.
  - Trost, B. M.; Shi, Y. *J. Am. Chem. Soc.* **1993**, *115*, 12491–12509.
  - Laurent, P.; Braekman, J.-C.; Daloze, D. *Eur. J. Org. Chem.* **2000**, 2057–2062.
  - Rougnon-Glasson, S.; Tratrat, C.; Canet, J.-L.; Chalard, P.; Troin, Y. *Tetrahedron: Asymmetry* **2004**, *15*, 1561–1567.
  - Bacos, D.; Célérier, J.-P.; Marx, E.; Rosset, S.; Lhommet, G. *J. Heterocycl. Chem.* **1990**, *27*, 1387–1391.

# Colorimetric calcium-response of $\beta$ -lactosylated $\mu$ -oxo-bis-[5,15-*meso*-diphenylporphyrinatoiron(III)]

Teruaki Hasegawa, Munenori Numata, Masayoshi Asai, Masayuki Takeuchi and Seiji Shinkai\*

*Department of Chemistry and Biotechnology, Graduate School of Engineering, Kyushu University, Hakozaki, 6-10-1, Higashi-ku, Fukuoka 812-8581, Japan*

Received 19 April 2005; revised 20 May 2005; accepted 23 May 2005

Available online 29 June 2005

**Abstract**— $\beta$ -Lactosylated 5,15-*meso*-diphenylporphyrinatoiron(III) chloride was prepared by ironization of the corresponding free base porphyrin having acetylated lactoside-units followed by deacetylation with ammonia in a water–methanol mixture. The resultant 5,15-*meso*-bis( $\beta$ -lactosylphenyl)porphyrinatoiron(III) chloride showed unique colorimetric response to calcium cation. This colorimetric response is calcium-specific and no other cations, such as sodium, potassium, or magnesium ions induced such colorimetric response. Lines of evidence including UV–vis spectra under different conditions and TEM images strongly indicate that interdigitations of the corresponding  $\mu$ -oxo-dimers are responsible for this colorimetric change.

© 2005 Elsevier Ltd. All rights reserved.

## 1. Introduction

Carbohydrates exist as components of glycoproteins and glycolipids on cell surfaces and play substantial roles in various molecular recognition events (fertilization, differentiation, cell–cell adhesion, etc.).<sup>1,2</sup> These carbohydrates were mainly thought to be ligands for carbohydrate recognition proteins (lectins) for many years. However, an increasing interest has been placed on carbohydrate–carbohydrate interactions on cell surfaces, in which carbohydrates recognize carbohydrates in specific and, in most case, calcium-dependent manner.<sup>3–7</sup>

Glycosphingolipids (GSLs) on cell surface aggregate laterally to form ‘carbohydrate signaling domains’ that is associated with various signal transferring proteins (c-Src, FAK, Rho A, etc.).<sup>8–11</sup> Interactions between such carbohydrate signaling domains of the neighboring cells are essential in various cellular recognition events including compactions of embryos. However, because of the heterogeneity and fluidity of cell membrane, it is quite difficult to reveal detailed mechanisms of such carbohydrate–carbohydrate interactions. Simple and well-designed model systems are, therefore, highly required for the detailed and quantitative investigations.

The most interesting aspects of carbohydrate–carbohydrate

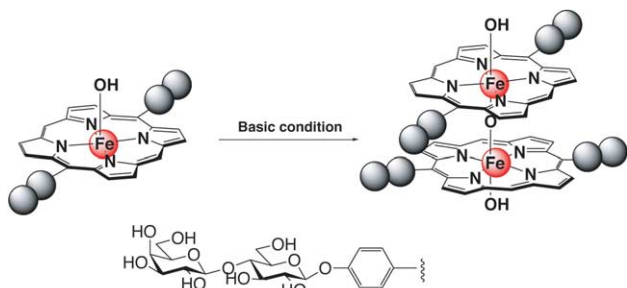
interactions include their multi-valency. It is well-known that the individual carbohydrate–carbohydrate interactions are quite weak, multiple copies of such interactions, however, can overcome such disadvantages of carbohydrates as recognition units. Some artificial models composed of clustered carbohydrates have been reported to investigate carbohydrate–carbohydrate interactions. For example, interactions between Langmuir monolayers composed of sialyllactosyl-ceramides ( $G_{M3}$ ) and micells presenting  $\beta$ -lactosides were investigated by using  $\pi$ -A isotherm.<sup>12–15</sup> However, only limited papers concerning the detailed mechanisms (packing, geometry, etc.) of such interactions can be seen in the literature. Such examples contain (1) a calcium-induced cross-shaped packing of two  $SLe^x$ -units linked through an alkyl spacer<sup>16</sup> and (2) a calcium-induced parallel packing of  $\beta$ -lactoside-units along with an  $\alpha$ -helical peptide.<sup>17</sup>

In a series of our research on artificial receptors having unique allosterisms,<sup>18,19</sup> we focused a new system based on  $\mu$ -oxo-bis[porphyrinatoiron(III)]s to investigate the detailed mechanisms of carbohydrate–carbohydrate interactions. It is well-known that porphyrinatoiron(III) can dimerize in a basic solution to form the corresponding  $\mu$ -oxo-bis[porphyrinatoiron(III)]s, in which two porphyrinatoirons are connected through a Fe–O–Fe bond.<sup>20</sup> Since these porphyrin-units can rotate through this axis,  $\mu$ -oxo-bis[porphyrinatoiron(III)] can afford useful scaffold to construct unique host molecules with multiple binding sites and allosterism, which should be quite advantageous to

*Keywords:* Carbohydrate–carbohydrate interactions.

\* Corresponding author. Tel. +81 92 642 3585; fax: +81 92 642 3611; e-mail: [seijitcm@mbox.nc.kyush-u.ac.jp](mailto:seijitcm@mbox.nc.kyush-u.ac.jp)

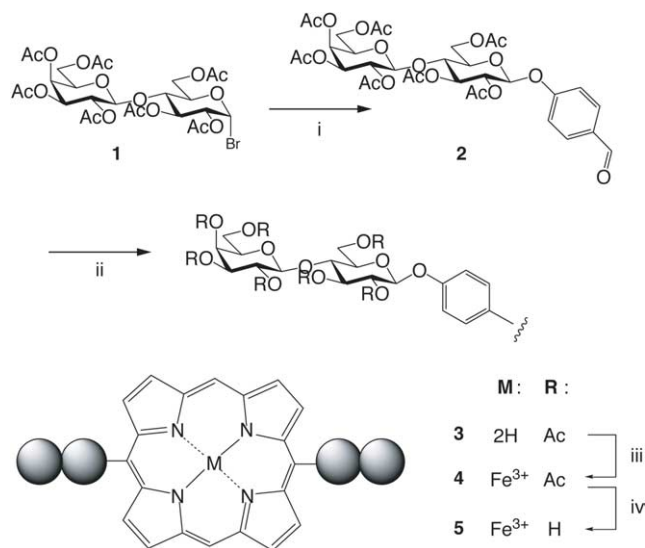
detect weak carbohydrate–carbohydrate interactions. Furthermore, host–guest bindings would be easily monitored by UV–vis and/or CD spectroscopy. Herein, we report an unique calcium-induced colorimetric response of  $\mu$ -oxo-bis[5,15-*meso*-diphenylporphyrinatoiron(III)] having four  $\beta$ -lactoside-appendages (Fig. 1).



**Figure 1.** Structure of 5,15-*meso*-diphenylporphyrinatoiron(III) having two  $\beta$ -lactosides (Por-Lac) and its dimerization in a basic solution to form the corresponding  $\mu$ -oxo-dimer.

## 2. Results and discussion

*per*-Acetyl- $\alpha$ -lactosyl-bromide (**1**) was coupled with 4-hydroxybenzaldehyde in a biphasic mixture of  $\text{CH}_2\text{Cl}_2$  and aqueous  $\text{Na}_2\text{CO}_3$  containing tetrabutyl ammonium bromide to afford *per*-acetyl- $\beta$ -lactosyl-benzaldehyde (**2**) in 69% yield (Scheme 1). Lyndsey-condensation of the *per*-acetyl- $\beta$ -lactosyl-benzaldehyde (1.0 equiv) and dipyrromethane (1.0 equiv) in dry  $\text{CH}_2\text{Cl}_2$  containing trifluoroacetic acid (1.2 equiv) was followed by oxidation by *p*-chloranil to afford 5,15-*meso*-bis(*p*-*per*-acetyl- $\beta$ -lactosylphenyl)porphyrin (**3**). The corresponding porphyrinatoiron(III) (**4**) was yielded by treating it with anhydrous  $\text{FeCl}_2$  in DMF at 60 °C. The following deacetylation in aqueous ammonia in methanol resulted in 5,15-*meso*-bis( $\beta$ -lactosylphenyl)porphyrinatoiron(III) (Por-Lac, **5**). We also synthesized a porphyrinatoiron(III) without carbohydrate-unit (Por-OMe, **7**) starting from

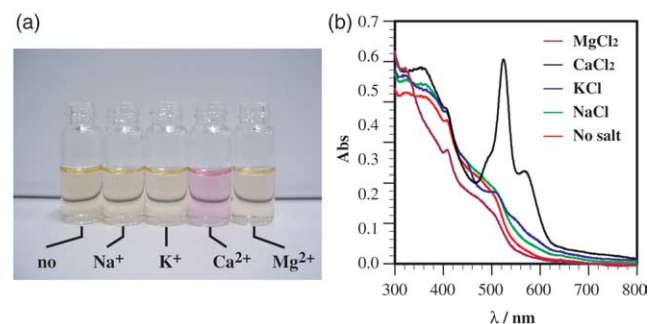


**Scheme 1.** Synthesis of 5,15-*meso*-bis( $\beta$ -lactosylphenyl)porphyrinatoiron(III) (Por-Lac): (i) 4-hydroxybenzaldehyde, TBAB,  $\text{Na}_2\text{CO}_3$ ,  $\text{CH}_2\text{Cl}_2/\text{H}_2\text{O}$ , rt; (ii) dipyrromethane, TFA,  $\text{CH}_2\text{Cl}_2$ , rt, then *p*-chloranil, rt; (iii)  $\text{FeCl}_2$ , DMF, 60 °C; (iv) aqueous ammonia, MeOH, rt.

4-methoxybenzaldehyde (two steps) through the similar synthetic scheme.

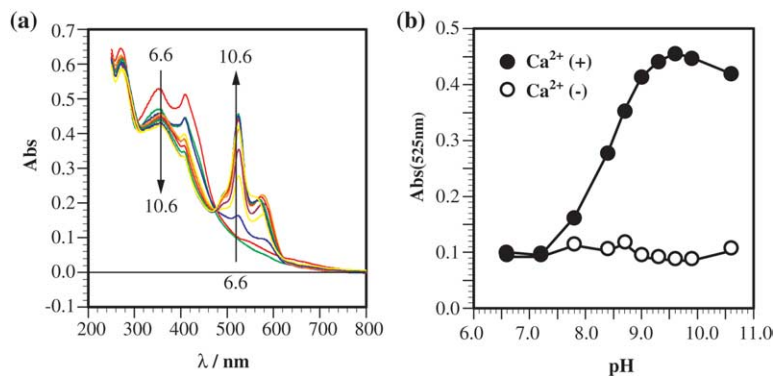
In our solubility test, Por-Lac was well-soluble in aqueous solvents containing 50% organic media such as *N*-methylpyrrolidone (NMP), *N,N*-dimethylformamide (DMF), dimethylsulfoxide (DMSO), etc. All these yellow solutions looked transparent, however, the UV–vis spectra indicated significant difference among them. For example, Por-Lac in aqueous DMF showed a sharp Soret-band adsorption at 400 nm, whereas the Soret-band was strongly suppressed in aqueous NMP. These data indicate that Por-Lac is mono-dispersed in aqueous DMF but aggregated in aqueous NMP. Of our great interest, the aggregation in aqueous NMP is quite essential for the calcium-response of Por-Lac, as described below.

Por-Lac showed unexpected and unique colorimetric response to calcium ions, that is, addition of  $\text{CaCl}_2$  to Por-Lac in Tris–HCl buffer (50 mM, pH 9.6, 50 v/v% NMP) induced a gradual change in the solution color from orange to pink, as shown in Figure 2a. The colorimetric change was slow and it required almost 10 h to be equilibrated. A UV–vis spectrum of Por-Lac (Fig. 2b) in the presence of  $\text{Ca}^{2+}$  showed a new peak at 525 nm. The colorimetric response was specific for calcium ion, and no other ions, such as potassium, sodium, nor magnesium could induce such a colorimetric response. The colorimetric response could be induced even by low calcium-concentrations ( $K_a = 660 \text{ M}^{-1}$ ).<sup>21</sup>

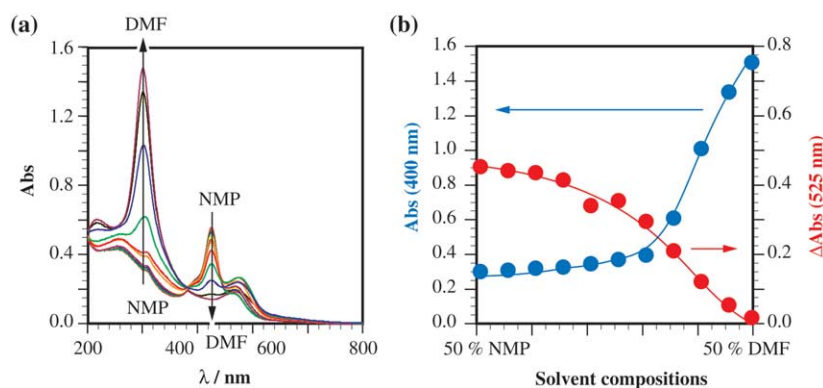


**Figure 2.** (a) Colorimetric response of Por-Lac to NaCl, KCl,  $\text{CaCl}_2$  and  $\text{MgCl}_3$ : [Por-Lac] =  $2.4 \times 10^{-4} \text{ M}$ , [KCl], [NaCl], [ $\text{CaCl}_2$ ] or [ $\text{MgCl}_3$ ] = 50 mM, 25 °C, Tris–HCl (pH 9.6, 50 mM, 50 v/v% NMP), 12 h after salt addition and (b) their UV–vis spectra.

To clarify the origin of this unique colorimetric response, we measured UV–vis spectra of Por-Lac in various solvent systems with different pH-values and organic co-solvents. As shown in Figure 3, the colorimetric calcium-response is strongly dependent on pH-values and appeared only under basic conditions ( $> \text{pH } 8.5$ ), confirming that the corresponding  $\mu$ -oxo-dimer is responsible for the calcium-response. In addition to the pH-dependence, organic co-solvents also have a critical influence on the calcium-response. Figure 4 shows the UV–vis spectra of Por-Lac in Tris–HCl buffer (50 mM, pH 9.6) containing 50 mM  $\text{CaCl}_2$  and 50 v/v% organic co-solvent (varying the DMF/NMP ratio). With increasing NMP ratio, the Soret-band is gradually weakened and the calcium-response simultaneously appears, indicating that the face-to-face interactions between porphyrin-units are essential for the calcium-response.



**Figure 3.** (a) UV-vis spectra of Por-Lac under various pH-conditions in the presence of  $\text{CaCl}_2$  and (b) pH-dependent Abs (525 nm) of Por-Lac:  $[\text{Por-Lac}] = 2.4 \times 10^{-4} \text{ M}$ ,  $[\text{CaCl}_2] = 50 \text{ mM}$ ,  $25^\circ \text{C}$ , Tris-HCl (pH 9.6, 50 mM, 50 v/v% NMP).



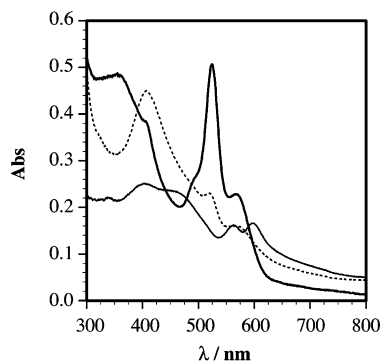
**Figure 4.** (a) UV-vis spectra of Por-Lac in Tris-HCl buffer containing 50 v/v% organic co-solvents (varying NMP/DMF ratio) in the presence of  $\text{CaCl}_2$ , and (b) Solvent-dependency of the UV intensities (400 and 525 nm):  $[\text{Por-Lac}] = 2.4 \times 10^{-4} \text{ M}$ ,  $[\text{CaCl}_2] = 50 \text{ mM}$ ,  $25^\circ \text{C}$ , Tris-HCl (pH 9.6, 50 mM, 50 v/v% organic co-solvents).

It should be noted that EDTA-addition could quench the colorimetric response and change the solution color from pink to orange, confirming that the origin of this colorimetric change can be attributed to the non-covalent interaction between Por-Lac and calcium ions (see ESI).

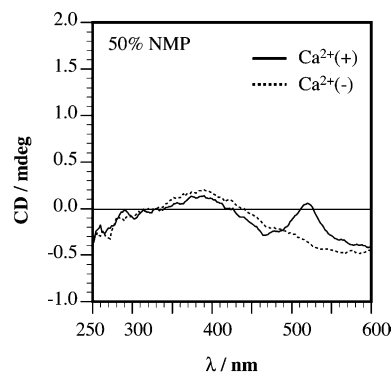
Structural modification of Por-Lac also provides useful information about the nature of this calcium-response. Porphyrinatoiron(III) having no carbohydrate-units (Por-OME as well as commercially available 2,3,7,8,12,13,17,18-octaethyl-porphyrinatoiron(III) chloride) showed no or

negligible calcium-response (Fig. 5). These data strongly suggest that carbohydrate-units play important roles in colorimetric calcium-response (calcium-binding itself and/or the resulting face-to-face interactions).

CD spectra of Por-Lac in the presence of calcium ions showed a new CD signal at 525 nm, supporting that chirally twisted packing of porphyrin-units induced by calcium cation (Fig. 6). Together with these data, we assume that the new peak should be assignable to the red-shifted Soret-band arising from J-aggregation of the  $\mu$ -oxo-dimer. Although



**Figure 5.** UV-vis spectra of Por-Lac (plane line), Por-OME (dotted line), and Por-OEt<sub>8</sub> (thin line), in the presence of  $\text{CaCl}_2$ :  $[\text{Por-derivatives}] = 2.4 \times 10^{-4} \text{ M}$ ,  $[\text{CaCl}_2] = 50 \text{ mM}$ ,  $25^\circ \text{C}$ , Tris-HCl (pH 9.6, 50 mM, 50 v/v% NMP).

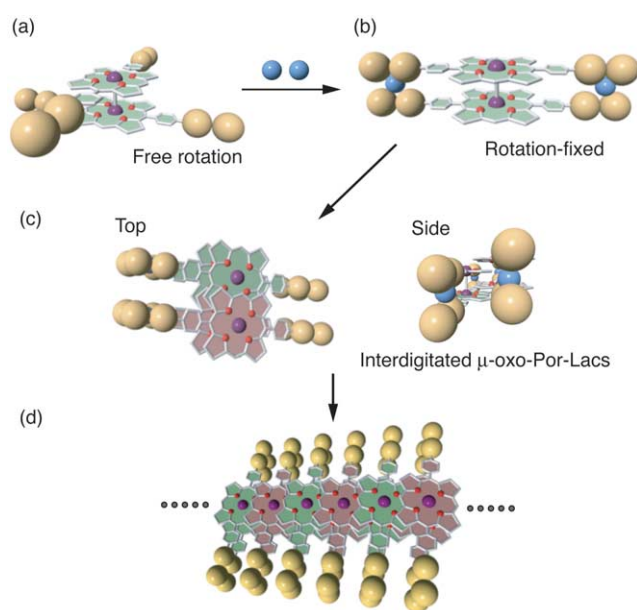


**Figure 6.** CD spectra of Por-Lac in the presence (plane line) and absence (dotted line) of  $\text{CaCl}_2$ :  $[\text{Por-Lac}] = 2.4 \times 10^{-4} \text{ M}$ ,  $[\text{CaCl}_2] = 50 \text{ mM}$ ,  $25^\circ \text{C}$ , Tris-HCl (pH 9.6, 50 mM, 50 v/v% NMP).



more data should be collected to firmly establish the detailed mechanism, this slided orientation (J-aggregation) of  $\mu$ -oxo-Por-Lac can reasonably explain the red-shifted Soret-band to induce the colorimetric change.

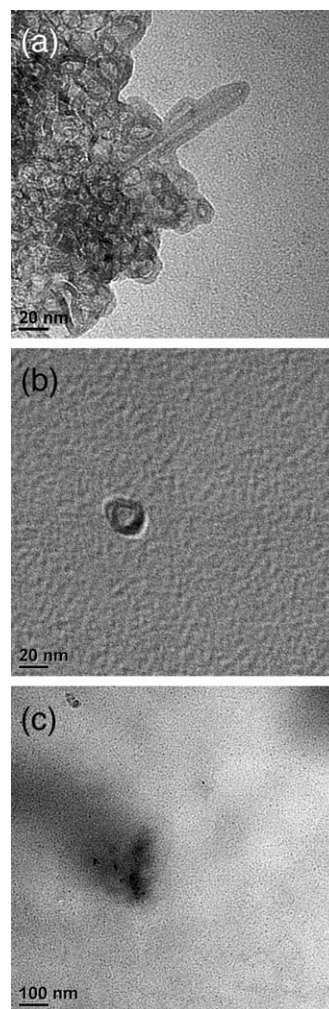
In addition to these data, the stoichiometric analysis (Job plot) showing ca. 1:2 stoichiometry between the  $\mu$ -oxo-Por-Lac and  $\text{Ca}^{2+}$  provides one possible mechanism (Fig. 7). In this picture, calcium ions interact with two carbohydrate-units to fix the molecular rotation and then, the resulting  $\mu$ -oxo-Por-Lacs are interdigitated owing to the hydrophobic interactions among porphyrin planes. It should be emphasized here, that such interdigitations can be achieved only when the two pairs of  $\beta$ -lactoside-appendages were packed in a parallel fashion and huge hydrophobic clefts were formed at the both sides of the rotation-fixed  $\mu$ -oxo-dimer.



**Figure 7.** One possible mechanism to induce the colorimetric calcium-response, in which (a) two calcium cations binds to the  $\beta$ -lactoside-appendages of  $\mu$ -oxo-Por-Lac to (b) fix the molecular rotation followed by (c) interdigitation of two such fixed  $\mu$ -oxo-Por-Lacs resulting a dimerization and (d) further oligomerizations.

We also measured cold spray ionization (CSI) mass spectra to support the above idea. Por-Lac ( $m/z = 1196.30$ ) in aqueous NMP (pH 9.6) in the absence of  $\text{CaCl}_2$  showed no clear peak in the range of  $m/z = 500$ – $3000$ , supporting its aggregation under this condition. However, Por-Lac in the presence of  $\text{CaCl}_2$  (50 mM) showed clear peaks at  $m/z = 271.84$ ,  $372.39$ , and  $472.96$  that can be assigned to the oligomers of  $\mu$ -oxo-Por-Lac associated with calcium ions and water molecules ( $(\mu\text{-oxo-Por-Lac})_n(\text{Por-Lac})_1(\text{H}_2\text{O})_2(\text{Ca}^{2+})_{12}$  where  $n = 2$  (calcd 272.06),  $3$  (calcd 372.42), or  $4$  (472.78), respectively).

Of our great interest, the calcium-addition also has critical impacts on morphology of Por-Lac aggregates. Figure 8a and b show transmission electron microscopic (TEM) images of Por-Lac aggregates in the presence of  $\text{CaCl}_2$ , in which some nanotubular structures, along with predominant spherical ones, were observed. On the contrary, Por-Lac without  $\text{CaCl}_2$  showed amorphous aggregates, and neither



**Figure 8.** TEM images of Por-Lac in the presence (a and b) and absence (c) of  $\text{CaCl}_2$ :  $[\text{Por-Lac}] = 2.4 \times 10^{-4}$  M,  $[\text{CaCl}_2] = 50$  mM,  $25^\circ\text{C}$ , Tris-HCl (pH 9.6, 50 mM, 50 v/v% NMP), 12 h after salt addition.

spherical nor nanotubular structure was observed (Fig. 8c). We assumed that the repeating interdigitations of  $\mu$ -oxo-Por-Lacs (Fig. 7d) should play substantial roles in constructions of such unique and definite superstructures.

### 3. Conclusion

We designed the  $\mu$ -oxo-bis[5,15-*meso*-bis( $\beta$ -lactosyl-phenyl)porphyrinatoiron(III)] to detect calcium-mediated lactoside–lactoside interactions based on its CD spectral changes. Although such a calcium-induced CD spectral changes can be observed, we also found its unexpected and unique colorimetric response for calcium ions. The mechanism we proposed in Figure 7, that is calcium-mediated parallel packings of two  $\beta$ -lactoside-appendages and the resultant interdigitations of the rotation-fixed  $\mu$ -oxo-dimers, can reasonably explain the observed spectral changes. Furthermore, the calcium-induced morphological change from amorphous aggregates to tubular/spherical superstructures is also quite of interest since such calcium-dependent morphological changes are frequently observed in natural cell lines (compaction of embryos, etc.), although their mechanisms are quite different from each other.

## 4. Experimental

### 4.1. General

<sup>1</sup>H NMR spectra were acquired on a Bruker DRX600 (Bruker Co., Ltd) in CDCl<sub>3</sub> at 600 MHz. The chemical shifts were reported in ppm ( $\delta$ ) relative to Me<sub>4</sub>Si. Circular dichroism (CD) spectra were measured on JASCO 720WI Circular Dichroism Spectrometer. Matrix assisted laser desorption ionization time-of-flight (MALDI-TOF) mass spectra were recorded on PerSeptive Biosystems Voyager-DEP Biospectrometry Workstation. Silica gel 60 N (particle size 40–50  $\mu$ m) for column chromatography was purchased from KANTO CHEMICAL Co. INC. Thin-layer chromatography (TLC) was carried out with Merck TLC aluminum sheets pre-coated with silica gel 60 F<sub>254</sub>.

**4.1.1. *p*-(2,3,6,2',3',4',6'-Hepta-*O*-acetyl- $\beta$ -lactosyl)benzaldehyde (2).** To 2,3,6,2',3',4',6'-hepta-*O*-acetyl-lactosyl bromide (18.03 g) and 4-hydroxybenzaldehyde (5.12 ml) in the mixture of CH<sub>2</sub>Cl<sub>2</sub> (50 ml) and aqueous Na<sub>2</sub>CO<sub>3</sub> (70 ml), tetrabutylammonium bromide (0.08 g) was added and the vigorous stirring was continued for 24 h at room temperature. The resulting mixture was diluted with CH<sub>2</sub>Cl<sub>2</sub> and washed with 0.5 N HCl aq and NaHCO<sub>3</sub> aq repeatedly. The organic layer was dried over anhydrous Na<sub>2</sub>SO<sub>4</sub>, filtered, evaporated, and purified through column chromatography on silica-gel (CHCl<sub>3</sub>/MeOH=25:1) to give *p*-(2,3,6,2',3',4',6'-hepta-*O*-acetyl- $\beta$ -lactosyl)benzaldehyde (69%): <sup>1</sup>H NMR(CDCl<sub>3</sub>, TMS): 9.93 (s, 1H), 7.85 (d, *J*=8.51 Hz, 2H), 7.08 (d, *J*=8.66 Hz, 2H), 5.37 (d, *J*=3.10 Hz, 1H), 5.31 (t, *J*=8.33 Hz, 1H), 5.21 (t, *J*=7.49 Hz, 1H), 5.19 (d, *J*=7.69 Hz, 1H), 5.14 (dd, *J*=7.93, 10.34 Hz, 1H), 4.98 (dd, *J*=3.36, 10.46 Hz, 1H), 4.52 (d, *J*=7.79 Hz, 1H), 4.52 (dd, *J*=1.21, 13.30 Hz, 1H), 4.16 (dd, *J*=6.44, 10.84 Hz, 1H), 4.14 (dd, *J*=4.64, 10.49 Hz, 1H), 4.09 (dd, *J*=7.41, 11.13 Hz, 1H), 3.92 (t, *J*=9.73 Hz, 1H), 3.91–3.89 (m, 1H), 3.87–3.84 (m, 1H), 2.17 (s, 3H), 2.09 (s, 3H), 2.08 (s, 3H), 2.07 (s, 9H), 1.98 (s, 3H); [M+H]<sup>+</sup>=741.6 (calcd 741.7); IR (ATR, cm<sup>-1</sup>) 1749 (acetyl).

**4.1.2. 5,15-meso-Bis(*p*-2,3,6,2',3',4',6'-hepta-*O*-acetyl- $\beta$ -lactosylphenyl)porphyrin (3).** To *p*-(2,3,6,2',3',4',6'-hepta-*O*-acetyl- $\beta$ -lactosyl)benzaldehyde (1.01 g) and dipyrromethane (0.20 g) in dry CH<sub>2</sub>Cl<sub>2</sub> (40 ml), trifluoroacetic acid (125  $\mu$ l) was added. The stirring was continued for 15 h at room temperature under N<sub>2</sub> atmosphere and then, *p*-chloranil was added. After additional 1 h stirring, triethylamine was added and the resulting mixture was evaporated to dryness. Insoluble materials were separated through silica-gel packed column using chloroform as an eluent. The fractions were combined, evaporated, and purified by chromatography on a silica gel column (30 cm long; 3 cm i.d.; toluene/ethyl acetate=2:3 in v/v) to give 5,15-meso-di(lactosylphenyl)-porphyrin as a purple powder (19%): <sup>1</sup>H NMR(CDCl<sub>3</sub>, TMS): 10.31 (s, 2H), 9.39 (d, *J*=2.70 Hz, 4H), 9.07 (d, *J*=2.70 Hz, 4H), 8.19 (d, *J*=7.62 Hz, 4H), 7.42 (d, *J*=7.62 Hz, 4H), 5.49–5.40 (m, 8H), 5.20 (t, *J*=9.09 Hz, 2H), 5.03 (d, *J*=10.42 Hz, 2H), 4.66 (d, *J*=11.69 Hz, 2H), 4.61 (d, *J*=7.86 Hz, 2H), 4.32–3.95 (m, 12H), 2.24 (s, 6H), 2.20 (s, 6H), 2.17 (s, 12H), 2.12 (s, 6H), 2.10 (s, 6H), 2.00 (s, 6H); [M+H]<sup>+</sup>=1732.4 (calcd 1732.6); IR (ATR, cm<sup>-1</sup>) 1757 (acetyl).

**4.1.3. 5,15-meso-Bis(*p*-2,3,6,2',3',4',6'-hepta-*O*-acetyl- $\beta$ -lactosylphenyl)porphyrinatoiron(III) (4).** To 5,15-meso-bis(*p*-2,3,6,2',3',4',6'-hepta-*O*-acetyl-lactosyl)phenyl)porphyrin (139 mg) in dry DMF (20 ml), anhydrous FeCl<sub>2</sub> (310 mg) was added and the stirring was continued for 6 h at 80 °C under N<sub>2</sub> atmosphere. The resulting solution was diluted with ethyl acetate and washed with NaCl saturated aqueous solution several times. The organic layer was dried over Na<sub>2</sub>SO<sub>4</sub>, filtered, evaporated to dryness. The residues was purified by chromatography on a silica gel column (30 cm long; 3 cm i.d.; CHCl<sub>3</sub>/MeOH=20:1 ~9:1 in v/v) to give 5,15-meso-bis(*p*-2,3,6,2',3',4',6'-hepta-*O*-acetyl-lactosylphenyl)porphyrinatoiron(III) as a orange powder (78%): [M]<sup>+</sup>=1785.1 (calcd 1785.4); IR (ATR, cm<sup>-1</sup>) 1751 (acetyl).

**4.1.4. 5,15-meso-Bis( $\beta$ -lactosylphenyl)porphyrinatoiron(III) (5).** To 5,15-meso-bis(*p*-2,3,6,2',3',4',6'-hepta-*O*-acetyl- $\beta$ -lactosylphenyl)porphyrinatoiron(III) (32 mg) in methanol (20 ml) aqueous ammonia (10 ml) was added and the mixture was stirred at room temperature for 3 h. The resulting mixture was condensed by evaporation to remove ammonia vapor and then, diluted with water and lyophilized to give 5,15-meso-bis( $\beta$ -lactosylphenyl)porphyrinatoiron(III) as a brown powder (quant.). We could not confirm the purity of this final product owing to its magnetic nature. The purity of this compound was, therefore, evaluated by HPLC analysis that showed only one, clear, and symmetrical peak (see ESI): [M+Na]<sup>+</sup>=1198.1 (calcd 1197.9); IR (ATR, cm<sup>-1</sup>) 3218 (–OH).

**4.1.5. 5,15-meso-Bis(*p*-methoxyphenyl)porphyrin (6).** To *p*-anisaldehyde (0.89 ml) and dipyrromethane (1.1 g) in dry CH<sub>2</sub>Cl<sub>2</sub> (230 ml) trifluoroacetic acid (0.60  $\mu$ l) was added. The stirring was continued for 15 h at room temperature under N<sub>2</sub> atmosphere and then, *p*-chloranil (1.0 g) was added. After additional 1 h stirring, triethylamine was added and the resulting mixture was evaporated to dryness. Insoluble materials were separated through silica-gel packed column using chloroform as an eluent. The fractions were combined, evaporated, and purified by chromatography on a silica gel column (30 cm long; 3 cm i.d., chloroform/methanol (25:1)) to give 5,15-meso-bis(*p*-methoxyphenyl)porphyrin as a purple powder (23%): <sup>1</sup>H NMR(CDCl<sub>3</sub>, TMS): 10.23 (s, 2H), 9.32 (d, *J*=4.4 Hz, 4H), 9.04 (d, *J*=4.3 Hz, 4H), 8.12 (d, *J*=8.1 Hz, 4H), 7.28 (d, *J*=7.8 Hz, 4H), 4.06 (s, 6H), –3.15 (s, 2H); [M+H]<sup>+</sup>=523.3 (calcd 523.3).

**4.1.6. 5,15-meso-Bis(*p*-methoxyphenyl)porphyrinatoiron(III) (7).** To 5,15-meso-bis(*p*-methoxyphenyl)porphyrin (210 mg) in dry DMF (40 ml), anhydrous FeCl<sub>2</sub> (510 mg) was added and the stirring was continued for 6 h at 80 °C under N<sub>2</sub> atmosphere. The resulting solution was diluted with ethyl acetate and washed with NaCl saturated aqueous solution several times. The organic layer was dried over Na<sub>2</sub>SO<sub>4</sub>, filtered, evaporated to dryness. The residue was purified by chromatography on a silica gel column (30 cm long; 3 cm i.d.; CHCl<sub>3</sub>/MeOH=20:1 in v/v) to give 5,15-meso-bis(*p*-methoxyphenyl)-porphyrinatoiron(III) as a orange powder (69%): [M]<sup>+</sup>=577.3 (calcd 577.1).

### Acknowledgements

We are grateful to Prof. T. Hayashi of Kyushu University, Prof. H. Tamiaki of Ritsumeikan University and Prof. M. Nango of Nagoya Institute of Technology for their kindful suggestions. This work was supported by the Japan Science and Technology Corporation.

### Supplementary data

Supplementary data associated with this article can be found, in the online version, at [doi:10.1016/j.tet.2005.05.103](https://doi.org/10.1016/j.tet.2005.05.103)

### References and notes

1. Dwek, R. A. *Chem. Rev.* **1996**, *96*, 683.
2. Mammen, M.; Choi, S.-K.; Whitesides, G. M. *Angew. Chem., Int. Ed.* **1998**, *37*, 2754.
3. Kojima, N.; Hakomori, S. *J. Biol. Chem.* **1991**, *266*, 17552.
4. Iwabuchi, K.; Handa, K.; Hakomori, S. *J. Biol. Chem.* **1998**, *273*, 33766.
5. Hakomori, S.; Nudelman, E. D.; Levery, S. B.; Solter, D.; Knowles, B. B. *Biochem. Biophys. Res. Commun.* **1981**, *100*, 1578.
6. Nores, G. A.; Dohi, T.; Taniguchi, M.; Hakomori, S. *J. Immunol.* **1987**, *139*, 3171.
7. Zheng, M.; Hakomori, S. *Arch. Biochem. Biophys.* **2000**, *93*.
8. Tillack, T. W.; Allietta, M.; Moran, R. E.; Young, W. W. *J. Biochim. Biophys. Acta* **1983**, *733*, 15.
9. Rock, P.; Alietta, M.; Young, W. W. J.; Thompson, T. E.; Tillack, T. W. *Biochemistry* **1990**, *29*, 8484.
10. Rock, P.; Alietta, M.; Young, W. W. J.; Thompson, T. E.; Tillack, T. W. *Biochemistry* **1991**, *30*, 19.
11. Iwabuchi, K.; Yamamura, S.; Prinetti, A.; Handa, K.; Hakomori, S. *J. Biol. Chem.* **1998**, *273*, 9130.
12. Santacroce, P. V.; Basu, A. *Angew. Chem., Int. Ed.* **2003**, *42*, 95.
13. Matsuura, K.; Kitakouji, H.; Oda, R.; Morimoto, Y.; Asano, H.; Ishida, H.; Kiso, M.; Kitajima, K.; Kobayashi, K. *Langmuir* **2002**, *18*, 6940.
14. Esnault, J.; Mallet, J.-M.; Zhang, Y.; Sinay, P.; Bouar, T. L.; Pincet, F.; Perez, E. *Eur. J. Org. Chem.* **2001**, 253.
15. Siuzdak, G.; Ichikawa, Y.; Caulfield, T. J.; Munoz, B.; Wong, C.-H.; Nicolaou, K. C. *J. Am. Chem. Soc.* **1993**, *115*, 2887.
16. Geyer, A.; Gege, C.; Schmidt, R. R. *Angew. Chem., Int. Ed.* **2000**, *39*, 3.
17. Hasegawa, T.; Sasaki, T. *Chem. Commun.* **2003**, *8*, 978.
18. Sugasaki, A.; Ikeda, M.; Takeuchi, M.; Shinkai, S. *Angew. Chem., Int. Ed.* **2000**, *39*, 3839.
19. Sugasaki, A.; Ikeda, M.; Takeuchi, M.; Koumoto, K.; Shinkai, S. *Tetrahedron* **2000**, *56*, 4717.
20. Takeuchi, M.; Imada, T.; Seiji, S. *J. Am. Chem. Soc.* **1996**, *118*, 10658.
21. We measured the UV–vis spectra of Por-Lac under various concentrations of CaCl<sub>2</sub> and carried out the computational curve fitting based on Hill plot.

# On-resin cyclization of a head-to-tail cyclopeptide using an allyldimethylsilyl polystyrene resin pre-loaded by metathesis

Mario Gonçalves,<sup>a,b</sup> Karine Estieu-Gionnet,<sup>b,c</sup> Georges Lain,<sup>b</sup> Mireille Bayle,<sup>b</sup> Natacha Betz<sup>a</sup> and Gérard Délérís<sup>b,\*</sup>

<sup>a</sup>CEA Saclay, DSM/DRECAM/LSI/LPI, Bat. 466, 91191 Gif-sur-Yvette Cedex, France

<sup>b</sup>CNRS UMR 5084 CNAB, Groupe de Chimie Bioorganique, Université Victor Segalen Bordeaux 2, 146 rue Léo Saignat, F-33076 Bordeaux Cedex, France

<sup>c</sup>INSERM E0113, Laboratoire des mécanismes moléculaires de l'angiogenèse, Avenue des Facultés-Université Bordeaux 1, 33405 Talence, France

Received 22 December 2004; revised 19 May 2005; accepted 23 May 2005

Available online 15 June 2005

**Abstract**—Here, we report the solid-phase synthesis of a 17-mer cyclopeptide which is expected to have anti-angiogenic properties. The peptidic synthesis is performed on an allyldimethylsilyl polystyrene support loaded by metathesis with a conveniently functionalized D-Tyrosine amino acid. The linear peptide was assembled by standard Fmoc chemistry and on-resin cyclization was enabled after selective deprotection of the C-terminal group with 2% hydrazine/DMF at room temperature. Final cleavage was realized under mild acidic conditions allowing to obtain a cyclopeptide under partially protected form.

© 2005 Elsevier Ltd. All rights reserved.

## 1. Introduction

Synthesis of head-to-tail cyclopeptides has attracted a considerable interest since the antibiotic gramicidin S was found to be a cyclic decapeptide.<sup>1</sup> Many antibiotics and toxins are also known to be cyclic peptides. Cyclization of amino acid sequences results in increased metabolic stability, potency, receptor selectivity and bioavailability.<sup>2–4</sup> Thus, cyclic peptides present suitable properties for investigating ligand–receptor interactions and structure–activity relationships<sup>5,6</sup> as well as for developing drugs with increased metabolic stability and receptor selectivity.<sup>7–9</sup>

Classical methods used to prepare cyclic peptides involve the synthesis of partially protected linear precursors either in solution or on solid-phase, their subsequent cleavage, and cyclization in solution; this one has to be performed under high dilution to minimize the formation of cyclodimers and oligomers. This synthetic procedure present some disadvantages, such as the necessity to isolate the desired peptide from the excess reagents, which leads in some cases

to a considerable loss of product. An attractive alternative includes solid support linkage to an amino acid side-chain and solid-phase chain assembly of the linear sequence, followed by cyclization while the peptide still remains anchored to the resin. The pseudo-dilution attributed to the solid-phase favours intramolecular reactions over intermolecular reactions.<sup>10</sup> So far, this method has been applied to aspartic and glutamic acid,<sup>11,12</sup> lysine,<sup>13</sup> tyrosine<sup>14</sup> and recently to serine and threonine<sup>15</sup> in the Fmoc strategy with different C-terminal protecting groups. To date, general and commercial synthesis of head-to-tail cyclic peptides has used only Allyl group (All) for temporary protection of the  $\alpha$ -COOH group of resin-bound amino acid.<sup>16</sup> The selective removal of the Allyl ester requires complex mixtures such as Pd(PPh<sub>3</sub>)<sub>4</sub>–AcOH–CHCl<sub>3</sub>–*N*-methylmorpholine (NMM) over an extended period of 2 h. Moreover, the use of tetrakis(triphenylphosphine)palladium (Pd(PPh<sub>3</sub>)<sub>4</sub>) requires inert atmosphere and degazed solvents. To overcome these drawbacks, a novel 4-{*N*-[1-(4,4-dimethyl-2,6-dioxocyclohexylidene)-3-methylbutyl]-amino} benzyl alcohol protecting group called Dmab has been described and used in the synthesis of a model cyclic heptapeptide<sup>17</sup> using standard Fmoc/*t*Bu procedures.<sup>18</sup> Recently, the use of this Dmab group as a temporary  $\alpha$ -COOH protecting group has been reported for automated solid-phase synthesis of an expanded (29-mer) cyclic peptide.<sup>19</sup>

**Keywords:** Solid-phase peptidic synthesis; Cyclic peptides; Metathesis; On-resin cyclization; Mitsunobu reaction.

\* Corresponding author. Tel./fax: +33 557 571002;  
e-mail: [gerard.deleris@u-bordeaux2.fr](mailto:gerard.deleris@u-bordeaux2.fr)

## 2. Results and discussion

In a previous work, we have reported the structural and the biological properties of a 17-mer cyclopeptide.<sup>20</sup> This 17-amino acid molecule, described as cyclic vascular endothelial growth inhibitor (cyclo-VEGI), revealed to be an attractive candidate for the development of novel angiogenesis inhibitor molecules useful for the treatment of cancer and other angiogenesis-related diseases, now under pre-clinical development. Angiogenesis allows the establishment of a vascular supply, which is fundamental not only for organ development but also for important processes in the adults such as wound healing and reproductive functions.<sup>21,22</sup> Angiogenesis is also implicated in the pathogenesis of a variety of disorders: proliferative retinopathies, age-related macular degeneration, tumors, rheumatoid arthritis and psoriasis. A number of angiogenesis regulators such as Vascular Endothelial Growth Factors (VEGFs) and Fibroblast Growth Factors (FGFs) have been identified.<sup>23–26</sup> Cyclo-VEGI encompasses residues 79–93 of VEGF which are involved in VEGF–VEGF type2 receptor interactions.

Efforts have been made to conveniently functionalize one of the cyclo-VEGI side-chain's group in order to broaden its biological properties.<sup>27</sup> Indeed, introduction of a terminal olefin could allow different ways of functionalization on cyclo-VEGI with the aim to enhance its anti-angiogenic properties. However, cyclo-VEGI basic side-chains (i.e., Arg, Lys and His) should be kept free due to their key role in VEGF–receptor interaction.

In this work, we describe a novel solid-phase peptide synthesis for such compounds which allows high functionalization potential. It takes advantage of an allyldimethylsilyl polystyrene support which could be loaded by cross metathesis with functionalized terminal olefins.<sup>28</sup> Then cyclo-VEGI was modified by substitution of *D*-Phenylalanine by *D*-Tyrosine, due to their structural homology. Hence, it affords a new side-chain group from which a terminal olefin could be introduced. **Scheme 1** shows a synthetic way to conveniently functionalize the commercially available Fmoc-*D*Tyr(OtBu)-OH (Novabiochem) to realize solid-phase peptide synthesis and on-resin cyclization. The esterification of the *D*-Tyrosine derivative with Dmab-OH was accomplished by activation with diisopropylcarbodiimide (DIPCDI) to yield Fmoc-*D*Tyr(OtBu)-ODmab **1**, which on treatment with trifluoroacetic acid (TFA) in CH<sub>2</sub>Cl<sub>2</sub> gave the required Fmoc-*D*Tyr-ODmab. Etherification has been attempted using K<sub>2</sub>CO<sub>3</sub> and 4-bromo-1-butene in acetone, but it was unsuccessful. Then etherification with an alkenyl group was realized under Mitsunobu reaction conditions, that is, with triphenylphosphine/diethyl azodicarboxylate (PPh<sub>3</sub>/DEAD) and but-3-en-1-ol, to yield

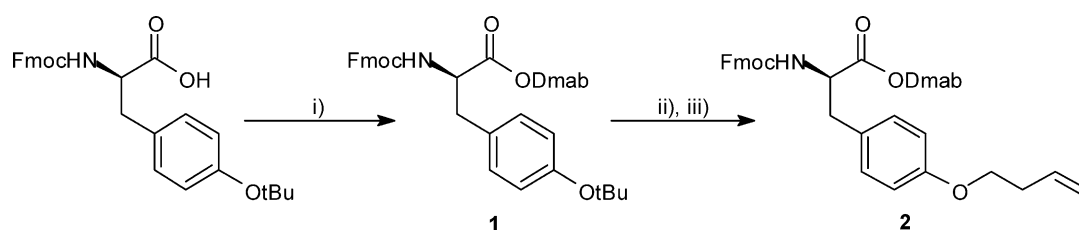
the expected compound **2**. To protect the  $\alpha$ -COOH of *D*-Tyrosine, Dmab group was preferred to allyl group, due to the metathesis step needed for resin loading. Indeed, allyl group could interfere with the terminal olefin of compound **2** during the loading step.

Compound **2** was then involved in our 17-mer cyclic peptide synthesis. Solid-phase peptide synthesis (**Scheme 2**) was performed on an allyldimethylsilyl polystyrene resin which has a silicon content of 1.3 mmol/g. Loading of the resin was achieved by cross-metathesis in refluxing CH<sub>2</sub>Cl<sub>2</sub> using 10 mol% of Grubb's catalyst (first generation) and 1 mmol of **2** per gram of resin. After 18 h, the resin was filtered off and washed with DMF, CH<sub>2</sub>Cl<sub>2</sub>, MeOH and Et<sub>2</sub>O. Residual diethyl ether was removed under vacuum, and a substitution level of 0.14 mmol/g was determined for this new pre-loaded resin. 0.1 mmol of this resin was then used for the linear peptide synthesis on a ABI-433A continuous-flow automated peptide synthesizer. Standard Fmoc chemistry was used throughout. Couplings were made with 10 M excess of the acylating amino acid by activation with a 0.45 M 2-(1*H*-benzotriazol-1-yl)-1,1,3,3-tetramethyluronium hexafluorophosphate/hydroxybenzotriazole (HBTU/HOBt) in DMF solution as recommended in the automated synthesizer manual for 0.1 mmol scale peptide synthesis. After completion of the peptide assembly, the resin was treated with 2% hydrazine/DMF at room temperature for 3 min. The treatment was repeated two more times, and the partially protected resin was thoroughly washed with DMF. For the intramolecular cyclization 3 M equiv of each benzotriazol-1-yloxy-tris(pyrrolidino)phosphonium hexafluorophosphate (PyBOP) and HOBt were used in the presence of 6 M equiv of diisopropylethylamine (DIEA) for 72 h.

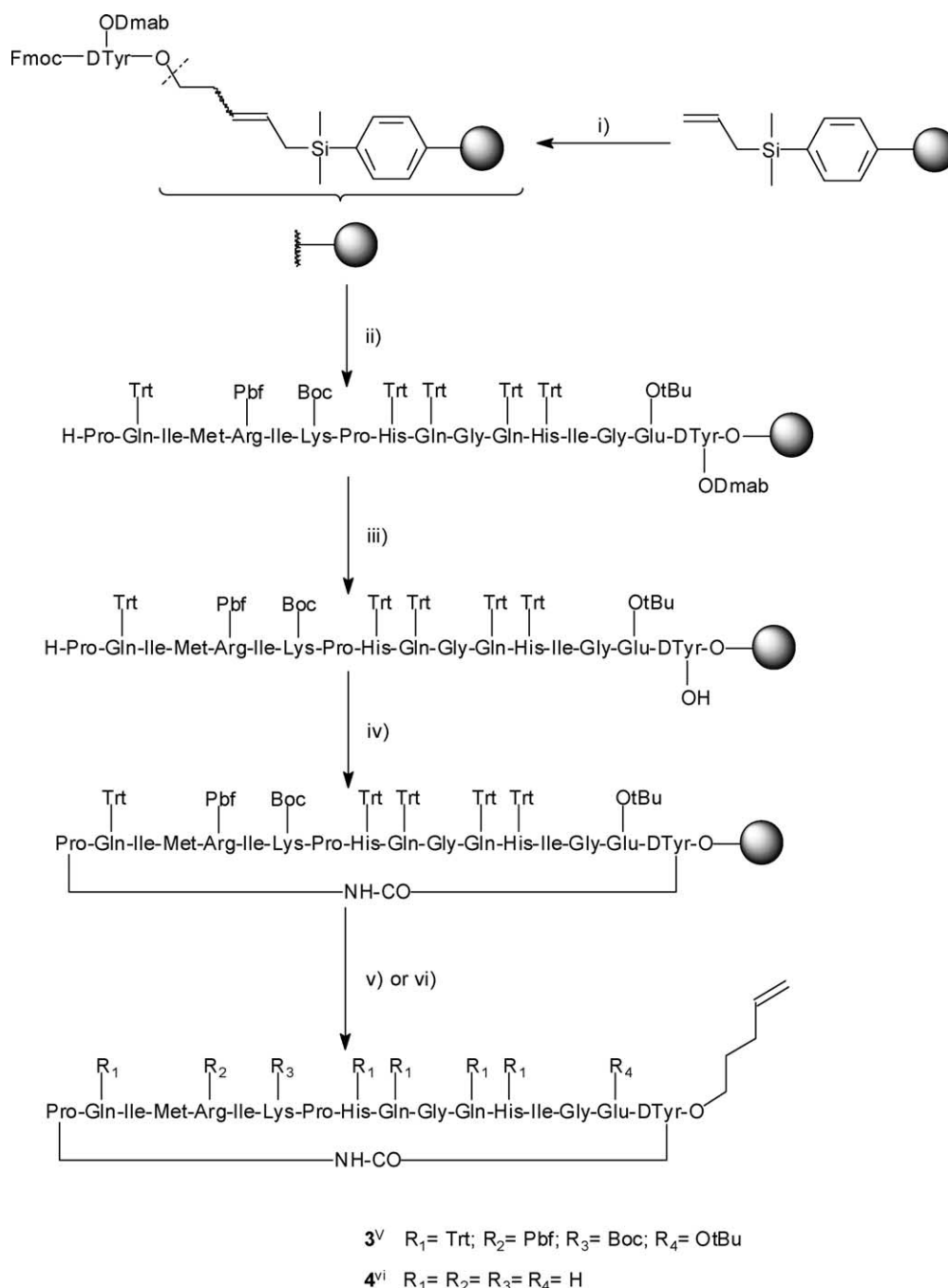
Peptide was cleaved from the resin with a solution of 1% TFA in CH<sub>2</sub>Cl<sub>2</sub> affording a protected modified cyclo-VEGI. A portion of this peptide was taken for final deprotection step employing a mixture of trifluoroacetic acid (TFA) in the presence of suitable scavengers to obtain the functionalized free cyclic peptide. Peptides were purified by reverse-phase high performance liquid chromatography (RP-HPLC) and MALDI mass spectrometry analysis gave the expected mass results.

## 3. Conclusion

To sum up, we have presented here, a new way to synthesize a cyclic peptide with one side-chain selectively functionalized which was obtained directly after cleavage from the resin. To our knowledge this is the first time that a peptide synthesis was performed on allyldimethylsilyl polystyrene resin. Thus this 17 amino-acid anticancer cyclic peptide



**Scheme 1.** Functionalization of Fmoc-*D*Tyr(OtBu)-OH. Reagents and conditions: (i) 1.5 equiv DIPCDI and HOBt, 3 equiv DIEA, CH<sub>2</sub>Cl<sub>2</sub>, rt, 18 h, 80%; (ii) TFA/CH<sub>2</sub>Cl<sub>2</sub> (95/5 v/v), rt, 3 h, 92%; (iii) 1.5 equiv of each PPh<sub>3</sub>-DEAD-but-3-en-1-ol, CH<sub>2</sub>Cl<sub>2</sub>, rt, 48 h, 52%.



**Scheme 2.** Solid phase synthesis of the 17-mer cyclopeptide. Reagents and conditions: (i) **2**, 10% mol  $\text{Cl}_2(\text{PPh}_3)_2\text{Ru}=\text{CHPh}$ ,  $\text{CH}_2\text{Cl}_2$ ; (ii) 16 cycles of Fmoc/*t*Bu solid-phase peptide synthesis a—20% piperidine/*N*-methylpyrrolidone (NMP), b—Fmoc-AA-OH, HBTU/HOBt/NMP, DIEA with final deprotection; (iii) 2% hydrazine/DMF; (iv) PyBOP, HOBt, DIEA, NMP; (v) TFA/triisopropylsilane (Tis)/thioanisole/water/phenol; (vi) 3% TFA/ $\text{CH}_2\text{Cl}_2$ .

could be obtained either under protected or unprotected form. Our synthetic approach opens the door to subsequent functionalizations such as radio-labelling or dimerization of cyclopeptide **3** and study in order to investigate the structural and biological properties of these new compounds.

## 4. Experimental

### 4.1. General information

MALDI mass spectra were run using a MALDI-TOF Reflex

III Bruker apparatus, and HRMS were run on a LCT premier from Waters. For the NMR spectra, a Bruker Avance 300 was used. Chemical shifts are reported in parts per million relative to tetramethylsilane as an internal standard (in NMR description s=singlet, d=doublet, t=triplet, q=quartet, m=multiplet, br=broad peak). UV measurements were taken on a Genesys 5 Spectronic Instruments spectrophotometer. For column chromatography, 63–200 mesh silica gel 60 (VWR International) was used as the stationary phase.

The *N*-(9-Fluorenylmethoxycarbonyl, Fmoc) protected

natural aminoacids and allyldimethylsilyl polystyrene resin were purchased from Advanced Chemtech. All trifunctional aminoacids were suitably protected. The  $\alpha$ -carboxyl group of D-Tyrosine was protected with the 4-{N-[1-(4,4-dimethyl-2,6-dioxocyclohexylidene)-3-methylbutyl]-amino} benzyl alcohol (Dmab) group. The  $\epsilon$ -amino group of lysine was protected with the (*tert*-butoxy)carbonyl (Boc) group. The histidine imidazole group and the amide group of glutamine were protected with the triphenylmethyl (Trityl, Trt) group. The guanidino function of arginine was protected with the 2,2,4,6,7-pentamethyldihydrobenzofuran-5-sulfonyl (Pbf) group and the  $\omega$ -carboxyl group of glutamic acid was protected with the *tert*-butyl (*t*Bu) group. Solution of 0.45 M 2-(1H-benzotriazol-1-yl)-1,1,3,3-tetramethyluronium hexafluorophosphate (HBTU) in *N*-hydroxybenzotriazole (HOBt) was purchased from Applied Biosystems. Diethyl azodicarboxylate (DEAD), diisopropylethylamine (DIEA), dimethylformamide (DMF), phenol, thioanisole, trifluoroacetic acid (TFA), triisopropylsilane and triphenylphosphine were purchased from Aldrich. Diethyl ether, piperidine and potassium hydroxide were purchased from Avocado. Hydrazine was purchased from Acros and Grubb's 1<sup>st</sup> generation catalyst was purchased from Strem chemicals. Absolute ethanol, dichloromethane, ethyl acetate, *n*-hexane and methanol were purchased from J. T. Baker.

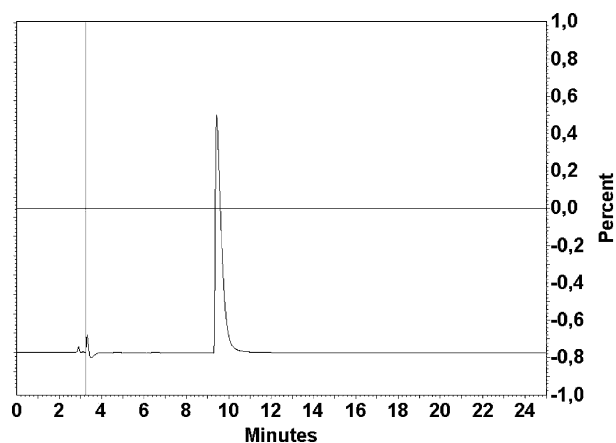
#### 4.2. Anchoring of Fmoc-DTyr(O-(CH<sub>2</sub>)<sub>2</sub>-CH=CH<sub>2</sub>)-ODmab to the allyldimethyl silyl polystyrene resin

Fmoc-DTyr(O-(CH<sub>2</sub>)<sub>2</sub>-CH=CH<sub>2</sub>)-ODmab (540 mg, 0.7 mmol) was dissolved in degazed CH<sub>2</sub>Cl<sub>2</sub> (25 mL). Then allyldimethylsilyl polystyrene resin (702 mg, 1.3 mmol g<sup>-1</sup>) and Grubb's first generation catalyst (28.9 mg, 35.11  $\mu$ mol) were successively added. The resulting suspension was refluxed under argon atmosphere overnight. Then Grubb's catalyst (28.9 mg, 35.11  $\mu$ mol) was added again and the reaction mixture was maintained under reflux for 12 h. The resin was filtered off and successively washed with DMF, CH<sub>2</sub>Cl<sub>2</sub>, MeOH and Et<sub>2</sub>O (100 mL of each). The residual diethyl ether was removed under high vacuum. The substitution level was determined spectrophotometrically by Fmoc cleavage. Fmoc-DTyr-(resin)-ODmab (5.4 mg) was introduced into a test tube and a solution of 20% piperidine in DMF was added (0.5 mL). 20% piperidine in DMF (0.5 mL) was also added to an empty test tube to serve as a blank. Over the next 15 min, the test tube with the resin was swirled two or three times to make sure all the resin has come in contact with the piperidine solution. DMF was added to both tubes to bring a volume of 50 mL. The blank was used to zero the UV spectrophotometer at 301 nm. The absorbance of the solution is 0.126. The substitution level was calculated from the formula:  $Abs_{301} \times Vol (mL) / (7800 \times m (g))$  and was determined to be 0.15 mmol/g.

#### 4.3. Peptide synthesis

Cyclo(DYFPQIMRIKPHQGQHIGE) was synthesized by Fmoc/*t*-Bu batch solid phase synthesis on an Applied Biosystems 433A automated peptide synthesizer. Pre-loaded Fmoc-DTyr(resin)-ODmab was used for the linear chain assembly. Subsequent Fmoc aminoacids were coupled

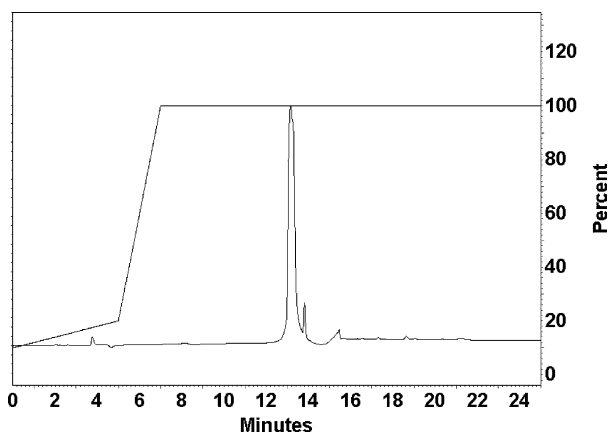
using a 4-fold excess of aminoacids activated as HOBt ester by means of a 0.45 M HBTU/HOBt solution. Removal of the Dmab protecting group was performed after N-terminal Fmoc deprotection. The peptidyl resin was weighed (1.12 g, 0.11 mmol) and placed on a frit in a syringe barrel and allowed to equilibrate for 5 min in DMF (20 mL/g of resin). The solvent was removed from the resin by applying a nitrogen pressure and the residue was resuspended in a solution of 2% hydrazine monohydrate in DMF (20 mL/g of resin). Reaction was allowed to proceed for 3 min with gentle manual agitation and the hydrazine treatment was repeated a further 2 times to ensure complete reaction. The peptide-resin was washed with DMF (5  $\times$  20 mL/g of resin) and resuspended in a solution of DIEA in DMF (1/9 v/v; 20 mL/g of resin) for 10 min. Finally, the peptidyl resin was washed successively with DMF, MeOH, Et<sub>2</sub>O and dried in vacuo over KOH. On-resin cyclization was performed by mixing peptidyl resin (890 mg, 0.09 mmol) with a solution of PyBOP (140.5 mg, 0.27 mmol), HOBt (36.5 mg, 0.27 mmol) and DIEA (93.5  $\mu$ L, 0.54 mmol) in 20 mL of NMP. The mixture was swelled at room temperature for 72 h. The peptidyl resin was washed with 50 mL of each NMP, CH<sub>2</sub>Cl<sub>2</sub>, MeOH and was dried under high vacuum. Final cleavage of cyclo(DYFPQIMRIKPHQGQHIGE) from the resin without loss of any side-chain protecting group was performed with a solution of 1% TFA in CH<sub>2</sub>Cl<sub>2</sub> (10 mL/g of resin). Cyclopeptidyl resin was mixed with dilute TFA and shake for 4 min. Then the solution was filtered and filtrate was collected in a flask containing a solution of 10% pyridine in MeOH (2 mL/10 mL of 1% TFA). It was repeated 5 times and resin was washed with 3  $\times$  30 mL of CH<sub>2</sub>Cl<sub>2</sub>, 3  $\times$  30 mL of MeOH, 2  $\times$  30 mL of CH<sub>2</sub>Cl<sub>2</sub> and 3  $\times$  30 mL of MeOH. Then filtrate was evaporated under reduced pressure to 5% of the volume. Thereafter, 40 mL of cold water were added to the residue to aid precipitation of the product which was isolated by filtration through a sintered glass funnel. Product was washed three times with fresh water, dissolved in a solution of CH<sub>3</sub>CN/H<sub>2</sub>O (70/30) with 0.1% TFA (eluant B) and then loaded onto a preparative Hibar Purosphere column C18. The elution was achieved using the following conditions: eluant A, 0.1% TFA in water; eluant B, 0.1% TFA in CH<sub>3</sub>CN/H<sub>2</sub>O (70/30); gradient: 10% of B at 0 min, 20% of B at 5 min, 100% of B at 7 min and 100% of B at 30 min;



Scheme 3. Protected peptide analytical HPLC performed on Hibar Purosphere C18 column with an isocratic of 1% TFA in CH<sub>2</sub>Cl<sub>2</sub> over a period of 25 min.

flow rate: 4 mL min<sup>-1</sup>; detector: 214 nm. Then 130 mg (35%) of protected cyclo(DYFPQIMRIKPHQGQHIGE) were obtained. MALDI mass spectrometry analysis gave the expected result (theoretical value: 3716.64 Da; experimental value: 3716.94 Da) and analytical HPLC on Hibar Purosphere column C18, eluted with an isocratic gradient of CH<sub>2</sub>Cl<sub>2</sub> with 0.1% TFA, gave the following profile: (Scheme 3)

A portion of the product was treated with 0.75 g of phenol in a TIS/thioanisole/H<sub>2</sub>O/TFA solution (1:2:2:40) for 3 h at room temperature. The product was precipitated from cold diethyl ether and filtered. Preparative Hibar Purosphere column C18 was achieved using the same conditions as below. Then MALDI mass spectrometry analysis gave the expected result (theoretical value: 2082 Da; experimental value: 2081.69 Da) and analytical HPLC on Hibar Purosphere column C18, eluted with a gradient between eluant A and B (see below), gave the following profile: (Scheme 4).



**Scheme 4.** Deprotected peptide analytical HPLC performed on Hibar Purosphere C18 column with a gradient of eluant A and B over a period of 25 min (eluant A: 1% TFA in water; eluant B: 1% TFA in CH<sub>3</sub>CN/H<sub>2</sub>O (70:30)).

#### 4.4. Compound 1: *N*- $\alpha$ -Fmoc-*O*-*tert*butyl-*D*-Tyrosine-4-{*N*-[1-(4,4-dimethyl-2,6-dioxocyclohexylidene)-3-methylbutyl]-amino} benzyl ester

To a solution of Fmoc-dTyr(*t*Bu)-OH (5 g; 10.88 mmol) in CH<sub>2</sub>Cl<sub>2</sub> was added successively DIEA (5.65 mL; 32.64 mmol), DIC (2.5 mL; 16.32 mmol) and HOBt (2.21 g; 16.32 mmol). After complete dissolution, Dmab-OH (5 g; 15.23 mmol) was added. Thereafter, the solution was stirred at room temperature for 18 h. Then the reaction mixture was filtered and washed with water (4  $\times$  60 mL). The organic layer was dried over MgSO<sub>4</sub> and filtrated. The solvent is evaporated under reduced pressure to give a greenish oil which was purified by silica gel chromatography (*n*-hexane/ethyl acetate, 60:40, 70:30). Then 6.68 g (80%) of compound **1** were obtained as a yellowish oil.

<sup>1</sup>H NMR (CDCl<sub>3</sub>)  $\delta$  ppm: 0.75 (d, 6H, (CH<sub>3</sub>)<sub>2</sub>-CH, <sup>3</sup>J<sub>H-H</sub> = 6.65 Hz), 1.06 (s, 6H, 2 CH<sub>3</sub>), 1.29 (s, 9H, 3 CH<sub>3</sub>), 1.82 (m, 1H, (CH<sub>3</sub>)<sub>2</sub>-CH), 2.38 (s, 2H, CH<sub>2</sub>), 2.48 (s, 2H, CH<sub>2</sub>), 2.99 (d, 2H, CH<sub>2</sub>-CH, <sup>3</sup>J<sub>H-H</sub> = 6.80 Hz), 3.06 (br s, 2H, CH<sub>2</sub> dTyr), 4.23 (t, 1H, CH Fmoc, <sup>3</sup>J<sub>H-H</sub> = 6.69 Hz), 4.36 (br s,

2H, CH<sub>2</sub> Fmoc), 4.65 (m, 1H, CH dTyr), 5.12 (s, 2H, CH<sub>2</sub> Bzl), 5.27 (d, 1H, NH dTyr, <sup>3</sup>J<sub>H-H</sub> = 8.07 Hz), 6.86 (d, 2H, CH<sub>Ar</sub> dTyr, <sup>3</sup>J<sub>H-H</sub> = 7.86 Hz), 6.94 (d, 2H, CH<sub>Ar</sub> dTyr, <sup>3</sup>J<sub>H-H</sub> = 7.86 Hz), 7.09 (d, 2H, CH<sub>Ar</sub> Bzl, <sup>3</sup>J<sub>H-H</sub> = 7.78 Hz), 7.27 (d, 2H, CH<sub>Ar</sub> Bzl, <sup>3</sup>J<sub>H-H</sub> = 7.78 Hz), 7.24–7.40 (m, 4H, CH<sub>Ar</sub> Fmoc), 7.54 (d, 2H, CH<sub>Ar</sub> Fmoc, <sup>3</sup>J<sub>H-H</sub> = 7.13 Hz), 7.74 (d, 2H, CH<sub>Ar</sub> Fmoc, <sup>3</sup>J<sub>H-H</sub> = 7.13 Hz), 15.3 (s, 1H, NH Dmab).

<sup>13</sup>C NMR (CDCl<sub>3</sub>)  $\delta$  ppm: 14.09, 22.56, 28.77, 29.54, 30.01, 37.63, 38.33, 47.08, 52.26, 53.75, 54.86, 66.24, 66.97, 78.45, 107.75, 119.96, 124.17, 125.01, 126.67, 127.01, 129.13, 129.70, 130.17, 134.59, 137.03, 141.28, 143.67, 154.56, 155.53, 171.44, 176.37, 196.37, 200.21.

IR (cm<sup>-1</sup>): 3307; 2957; 2869; 1725; 1644; 1557; 1507; 1451; 1414; 1387; 1366; 1325; 1163; 1051; 898; 759; 741.

MALDI: expected 770.97; found 769.32.

HRMS (ES<sup>+</sup>): calculated for C<sub>48</sub>H<sub>55</sub>N<sub>2</sub>O<sub>7</sub> 771.4009; found 771.3978.

$[\alpha]_D^{20}$  +23.14°, *c* 1.08 in CH<sub>2</sub>Cl<sub>2</sub>.

#### 4.5. Deprotection of compound 1: *N*- $\alpha$ -Fmoc-*D*-Tyrosine-4-{*N*-[1-(4,4-dimethyl-2,6-dioxocyclohexylidene)-3-methylbutyl]-amino} benzyl ester

To a solution of compound **1** (6.13 g, 7.95 mmol) in CH<sub>2</sub>Cl<sub>2</sub> (80 mL) was added TFA (80 mL). The reaction mixture was stirred at room temperature for 3 h. The solution was concentrated over reduced pressure to 5% of the volume. Cold water was added to the residue and a white precipitate appears. The solid was isolated by filtration and washed 3 times with cold water. Then it was dried in dessicator under high vacuum over KOH to give 5.22 g (92%) of deprotected compound **1** as a white solid (mp 92–94 °C).

<sup>1</sup>H Nmr (CDCl<sub>3</sub>)  $\delta$  ppm: 0.76 (d, 6H, (CH<sub>3</sub>)<sub>2</sub>-CH, <sup>3</sup>J<sub>H-H</sub> = 6.63 Hz), 1.06 (s, 6H, 2 CH<sub>3</sub>), 1.84 (m, 1H, (CH<sub>3</sub>)<sub>2</sub>-CH), 2.42 (br s, 4H, 2 CH<sub>2</sub>), 2.99 (m, 4H, CH<sub>2</sub>-CH and CH<sub>2</sub> dTyr), 4.18 (t, 1H, CH Fmoc, <sup>3</sup>J<sub>H-H</sub> = 6.59 Hz), 4.34–4.43 (m, 2H, CH<sub>2</sub> Fmoc), 4.65 (br s, 1H, CH dTyr), 5.13 (d, 1H, NH dTyr, <sup>3</sup>J<sub>H-H</sub> = 8.07 Hz), 5.27 (s, 2H, CH<sub>2</sub> Bzl), 6.66 (d, 2H, CH<sub>Ar</sub> dTyr, <sup>3</sup>J<sub>H-H</sub> = 7.86 Hz), 6.83 (d, 2H, CH<sub>Ar</sub> dTyr, <sup>3</sup>J<sub>H-H</sub> = 7.86 Hz), 7.07 (d, 2H, CH<sub>Ar</sub> Bzl, <sup>3</sup>J<sub>H-H</sub> = 7.89 Hz), 7.26 (d, 2H, CH<sub>Ar</sub> Bzl, <sup>3</sup>J<sub>H-H</sub> = 7.89 Hz), 7.24–7.39 (m, 4H, CH<sub>Ar</sub> Fmoc), 7.53 (d, 2H, CH<sub>Ar</sub> Fmoc, <sup>3</sup>J<sub>H-H</sub> = 7.32 Hz), 7.74 (d, 2H, CH<sub>Ar</sub> Fmoc, <sup>3</sup>J<sub>H-H</sub> = 7.32 Hz), 15.1 (s, 1H, NH Dmab).

<sup>13</sup>C NMR (CDCl<sub>3</sub>)  $\delta$  ppm: 22.59, 28.25, 29.53, 30.04, 37.44, 38.42, 47.19, 52.25, 54.93, 66.28, 67.03, 107.91, 115.47, 120.01, 125.02, 126.63, 127.75, 129.54, 130.44, 134.76, 141.34, 143.69, 155.11, 155.59, 171.44, 176.48, 196.61.

IR (cm<sup>-1</sup>): 3340; 2958; 2868; 1704; 1616; 1553; 1515; 1450; 1414; 1326; 1248; 1170; 1103; 1051; 827; 759; 740.

MALDI: expected 714.86; found 715.30.



HRMS (ES<sup>+</sup>): calculated for C<sub>44</sub>H<sub>47</sub>N<sub>2</sub>O<sub>7</sub> 715.3383; found 715.3384.

$[\alpha]_D^{20} +45.80^\circ$ ,  $c$  1.31 in CH<sub>2</sub>Cl<sub>2</sub>.

#### 4.6. Compound 2: *N*- $\alpha$ -Fmoc-*O*-butenyl-*D*-Tyrosine-4-{*N*-[1-(4,4-dimethyl-2,6-dioxocyclohexylidene)-3-methylbutyl]-amino} benzyl ester

To a solution of deprotected compound **1** (4.5 g, 6.29 mmol) in CH<sub>2</sub>Cl<sub>2</sub> (150 mL) was added triphenylphosphine (2.47 g, 9.44 mmol). After complete dissolution the solution was cooled at 0 °C and DEAD (1.48 mL, 9.44 mmol) was added. Thereafter, the reaction mixture was warmed to room temperature and then but-3-en-1-ol (0.81 mL, 9.44 mmol) was added. The reaction mixture was stirred at room temperature for 48 h. Then the solvent was evaporated under reduced pressure. The residue was purified by silica gel chromatography (*n*-hexane/ethyl acetate, 70:30) to give 2.54 g (52%) of compound **2** as a yellowish solid (mp: 104–106 °C).

<sup>1</sup>H NMR (CDCl<sub>3</sub>)  $\delta$  ppm: 0.75 (d, 6H, (CH<sub>3</sub>)<sub>2</sub>-CH, <sup>3</sup>J<sub>H-H</sub>=6.56 Hz), 1.06 (s, 6H, 2 CH<sub>3</sub>), 1.26–1.28 (m, 2H, =CH<sub>2</sub>), 1.82 (m, 1H, (CH<sub>3</sub>)<sub>2</sub>-CH), 2.38 (s, 2H, CH<sub>2</sub>), 2.51 (s, 2H, CH<sub>2</sub>), 2.98 (d, 2H, CH<sub>2</sub>-CH, <sup>3</sup>J<sub>H-H</sub>=6.86 Hz), 3.04 (br s, 2H, CH<sub>2</sub> <sup>D</sup>Tyr), 3.95 (t, 1H, CH Fmoc, <sup>3</sup>J<sub>H-H</sub>=6.57 Hz), 4.15–4.22 (m, 2H, O-CH<sub>2</sub> <sup>D</sup>Tyr), 4.41 (m, 2H, CH<sub>2</sub> Fmoc), 4.76 (br s, 1H, CH <sup>D</sup>Tyr), 5.06–5.16 (m, 4H, CH<sub>2</sub> Bzl and CH<sub>2</sub>-CH=), 5.21 (d, 1H, NH <sup>D</sup>Tyr, <sup>3</sup>J<sub>H-H</sub>=8.18 Hz), 5.85 (m, 1H, CH=CH<sub>2</sub>), 6.76 (d, 2H, CH<sub>Ar</sub> <sup>D</sup>Tyr, <sup>3</sup>J<sub>H-H</sub>=7.99 Hz), 6.94 (d, 2H, CH<sub>Ar</sub> <sup>D</sup>Tyr, <sup>3</sup>J<sub>H-H</sub>=7.99 Hz), 7.08 (d, 2H, CH<sub>Ar</sub> Bzl, <sup>3</sup>J<sub>H-H</sub>=8.03 Hz), 7.26 (d, 2H, CH<sub>Ar</sub> Bzl, <sup>3</sup>J<sub>H-H</sub>=8.03 Hz), 7.24–7.41 (m, 4H, CH<sub>Ar</sub> Fmoc), 7.53 (d, 2H, CH<sub>Ar</sub> Fmoc, <sup>3</sup>J<sub>H-H</sub>=7.09 Hz), 7.74 (d, 2H, CH<sub>Ar</sub> Fmoc, <sup>3</sup>J<sub>H-H</sub>=7.09 Hz), 15.3 (s, 1H, NH Dmab).

<sup>13</sup>C NMR (CDCl<sub>3</sub>)  $\delta$  ppm: 22.41, 28.04, 29.40, 30.01, 33.60, 37.37, 38.33, 46.93, 52.26, 53.75, 54.88, 66.22, 66.96, 67.15, 107.74, 115.35, 117.06, 119.80, 124.92, 126.46, 126.87, 127.54, 129.01, 130.12, 134.23, 137.03, 141.27, 143.67, 155.52, 158.19, 171.46, 176.37, 196.36, 200.21.

IR (cm<sup>-1</sup>): 3307; 2958; 1722; 1641; 1555; 1513; 1415; 1242; 1064; 761; 742.

MALDI: expected 768.95; found 769.03.

HRMS (ES<sup>+</sup>): calculated for C<sub>48</sub>H<sub>53</sub>N<sub>2</sub>O<sub>7</sub> 769.3853; found 769.3832.

$[\alpha]_D^{20} +7.69^\circ$ ,  $c$  1.30 in CH<sub>2</sub>Cl<sub>2</sub>.

#### Acknowledgements

This work was carried out in the frame of a collaboration between the Commissariat à l'Energie Atomique (CEA) and the Bio-Organic Chemistry Group (LRC DSM-98-15). The authors gratefully acknowledge the CEA and the Conseil Régional d'Aquitaine for providing financial support through the Ph.D grant of M. G. Financial Support from

the "Ligue Nationale contre le Cancer, Comité de la Gironde" is greatly acknowledged.

#### References and notes

- Conden, R. J.; Gordon, A. H.; Martin, A. J. P.; Synge, R. D. M. *Biochem. J.* **1947**, *28*, 596–602.
- Scott, C. P.; Abel Santos, E.; Wall, M.; Wahnou, D. C.; Benkovic, S. J. *Proc. Natl. Acad. Sci. U.S.A.* **1999**, *96*, 13638.
- Oligino, L.; Lung, F. D. T.; Sastry, L.; Bigelow, J.; Cao, T.; Curran, M.; Burke, J. T. R.; Wang, S.; Krag, D.; Roller, P. P.; King, C. R. *J. Biol. Chem.* **1997**, *272*, 29046.
- Gudmundsson, O. S.; Nimkar, K.; Gangwar, S.; Siahaan, T.; Borchardt, R. T. *Pharm. Res.* **1999**, *16*, 16.
- Pfaff, M.; Tangemann, K.; Müller, B.; Gurrath, M.; Müller, G.; Kessler, H.; Timpl, R.; Engel, J. *J. Biol. Chem.* **1994**, *269*, 20233–20238.
- Geyer, A.; Müller, G.; Kessler, H. *J. Am. Chem. Soc.* **1994**, *116*, 7735–7743.
- Hruby, V. J.; Bartosz-Bechowski, H.; Davis, P.; Slaninova, J.; Zalewska, T.; Stropova, D.; Porreca, F.; Yamamura, H. I. *J. Med. Chem.* **1997**, *40*, 3957–3962.
- McMurray, J. S.; Budde, R. J.; Ke, S.; Obeyesekere, N. U.; Wang, W.; Ramdas, L.; Lewis, C. A. *Arch. Biochem. Biophys.* **1998**, *355*, 124–130.
- Satoh, T.; Li, S.; Friedman, T. M.; Wiaderkiewicz, R.; Korngold, R.; Huang, Z. *Biochem. Biophys. Res. Commun.* **1996**, *224*, 438–443.
- Mazur, S.; Jayalekshmy, P. *J. Am. Chem. Soc.* **1978**, *101*, 677–683.
- Breipohl, G.; Knolle, J.; Stüber, W. *Int. J. Pept. Protein Res.* **1990**, *35*, 281–283.
- Albericio, F.; Van Abel, R.; Barany, G. *Int. J. Pept. Protein Res.* **1990**, *35*, 284–286.
- Alsina, J.; Rabanal, F.; Giralt, E.; Albericio, F. *Tetrahedron Lett.* **1994**, *35*, 9633–9636.
- Cabrele, C.; Langer, M.; Beck-Sickinger, A. G. *J. Org. Chem.* **1999**, *64*, 4353–4361.
- Yan, L. Z.; Edwards, P.; Flora, D.; Mayer, J. P. *Tetrahedron Lett.* **2004**, *45*, 923–925.
- Kates, S. A.; Sole, N. A.; Johnson, C. R.; Hudson, D.; Barany, G.; Albericio, F. *Tetrahedron Lett.* **1993**, *34*, 1549–1552.
- Chan, W. C.; Bycroft, B. W.; Evans, D. J.; White, P. D. *J. Chem. Soc., Chem. Commun.* **1995**, 2209.
- Fields, G. B.; Noble, R. L. *J. Int. Peptide Protein Res.* **1990**, *35*, 161.
- Cudic, M.; Wade, J. D.; Otvos, L. *Tetrahedron Lett.* **2000**, *41*, 4527–4531.
- Zilberberg, L.; Shinkaruk, S.; Lequin, O.; Rousseau, B.; Hagedorn, M.; Costa, F.; Caronzolo, D.; Balke, M.; Canron, X.; Convert, O.; Lain, G.; Gionnet, K.; Goncalves, M.; Bayle, M.; Bello, L.; Chassaing, G.; Deleris, G.; Bikfalvi, A. *J. Biol. Chem.* **2003**, *278*, 35564–35573.
- Folkman, J. *Nat. Med.* **1995**, *1*, 27–31.
- Garner, A. Vascular diseases. In *Pathobiology of ocular diseases*; Garner, A., Klintworth, G. K., Eds. 2nd ed.; Dekker: New York, 1994; pp 1625–1710.
- Ferrara, N. *Nat. Rev. Cancer* **2002**, *2*, 795–803.
- Javerzat, S.; Auguste, P.; Bikfalvi, A. *Trends Mol. Med.* **2002**, *8*, 483–489.

25. Bikfalvi, A.; Bicknell, R. *Trends Pharmacol. Sci.* **2002**, *23*, 576–582.
26. Risau, W. *Nature* **1997**, *386*, 671–674.
27. Gonçalves, M.; Estieu-Gionnet, K.; Lähn, G.; Bayle, M.;  
Canron, X.; Betz, N.; Bikfalvi, A.; Deleris, G. *Pharm. Res.* 2005, in press.
28. Schuster, M.; Lucas, N.; Blechert, S. *Chem. Commun.* **1997**, 823–824.

# Zinc templated synthesis—a route to get metal ion free tripodal ligands and lariat coronands, containing Schiff bases

Narinder Singh,<sup>a</sup> Maninder Singh Hundal,<sup>a</sup> Geeta Hundal<sup>a,\*</sup> and Martin Martinez-Ripoll<sup>b</sup>

<sup>a</sup>Department of Chemistry, Guru Nanak Dev University, Amritsar 143005, India

<sup>b</sup>Instituto de Química Física, Consejo Superior de Investigaciones Científicas, Rocasolano, Serrano-119, Madrid 28006, Spain

Received 22 March 2005; revised 4 May 2005; accepted 19 May 2005

Available online 21 June 2005

**Abstract**—A new series of tripodal receptors bearing imine linkages have been prepared in high yields, by a single step condensation reaction between tripodal aromatic amines and aldehydes, using zinc perchlorate as a template. The template cation leaves the pseudo cavity after the Schiff base condensation to give metal free multidentate ligands. These products have been characterized by <sup>1</sup>H, <sup>13</sup>C NMR, IR, elemental analysis, UV–vis absorption spectroscopy and X-ray crystallographic studies. It has been seen that the presence of a coordinating atom such as O, S, and N at position-2 with respect to the carbonyl group, is mandatory for the reaction to proceed. The template reaction has been also successfully employed to synthesize a lariat type coronand by reacting the tripodal amine with a dialdehyde.

© 2005 Elsevier Ltd. All rights reserved.

## 1. Introduction

A tripodal molecule may be considered as a cryptand which has been severed at two places.<sup>1</sup> These tripods have the ability to organize about and envelope a cation as do the cryptands hence they are termed as noncyclic cryptates.<sup>2</sup> In the case of flexible podands, the possible coordination modes are much more abundant than for rigid. The flexibility and low symmetry of the former means they can adopt different conformations according to the geometric needs of different metal ions. In most of the published examples of tripodands, the three arms are attached to nitrogen, making the compounds symmetrical tertiary amines.<sup>2–3</sup> The nitrogen readily inverts so the uncomplexed tripods are quite flexible and conformationally adaptable. Flexible tripodal ligands with aromatic core are relatively rare<sup>4</sup> although some of them have been prepared with various aims such as study of coordination polymers with network structures,<sup>5</sup> molecular recognition of anionic guest species,<sup>6</sup> acting as metal encapsulating ligands in organometallic chemistry,<sup>7</sup> formation of polynuclear complexes<sup>8</sup> and the formation of cylindrophanes.<sup>9</sup>

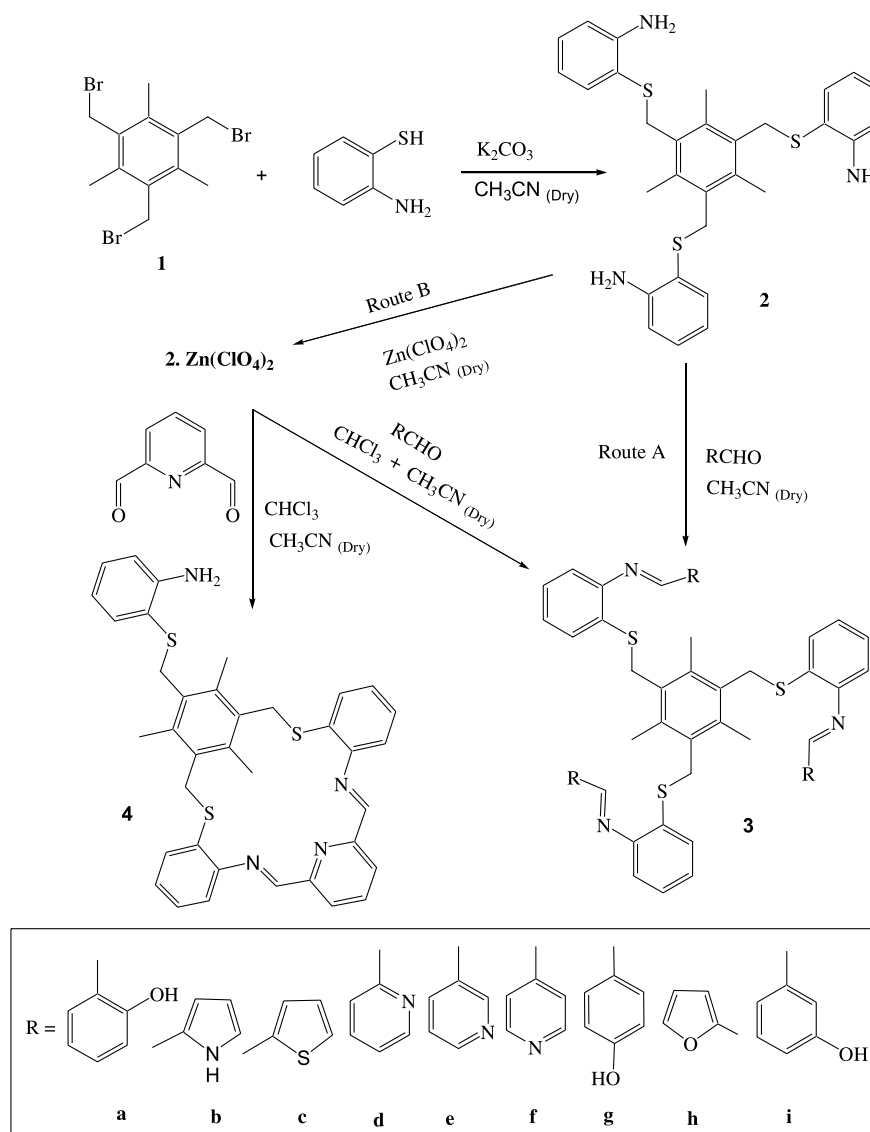
Schiff base condensation reactions have been extensively used in the preparation of an enormous range of coronands, cryptands and podands.<sup>10</sup> For this reason Schiff bases are required with high purity and good yield using simple synthetic routes. However, the purification of Schiff bases

by chromatographic methods leads to decomposition<sup>11</sup> whereas repeated recrystallizations as an alternative, are time consuming and are achieved at the cost of yield. These compounds are therefore, often formed in high yields by employing a thermodynamic template effect, which allows complexation to sequester the most stable metal–product compound. But if metal-free ligand is required for other experiments then the template cation has to be removed<sup>12</sup> either by extraction into an organic solvent or by complexation of the metal ion with a stronger coordinating ligand.<sup>13</sup>

To obviate these problems we have developed an efficient synthetic route using Zn<sup>2+</sup> mediated, thermodynamic templated syntheses to obtain Schiff bases from the condensation reactions of a newly synthesized tripodal amine **2** with various aldehydes. The procedure provides Schiff bases in high yields with the added advantages that after the synthesis of the ligand, the templating cation need not be removed as it leaves the tripods on its own and the condensation reaction rate is considerably fast. A new series of tripodal receptors **3a–d**, bearing an imine linkage have been prepared by a single step condensation reaction, using Zn(II) as a template, which leaves the pseudo cavity after the Schiff base condensation. The reactions have been monitored with the help of UV–vis absorption spectroscopy and <sup>1</sup>H, <sup>13</sup>C NMR, IR, elemental analysis, mass spectroscopy and X-ray crystallography have been used to characterize the products. The method has been extended to give an easy route for the synthesis of lariat crown compound **4**.

**Keywords:** Tripodands; Schiff's bases; Zinc templated.

\* Corresponding author. Tel.: +91 1832258803x3196; fax: +91 1832258820; e-mail: [geetahundal@yahoo.com](mailto:geetahundal@yahoo.com)



Scheme 1.

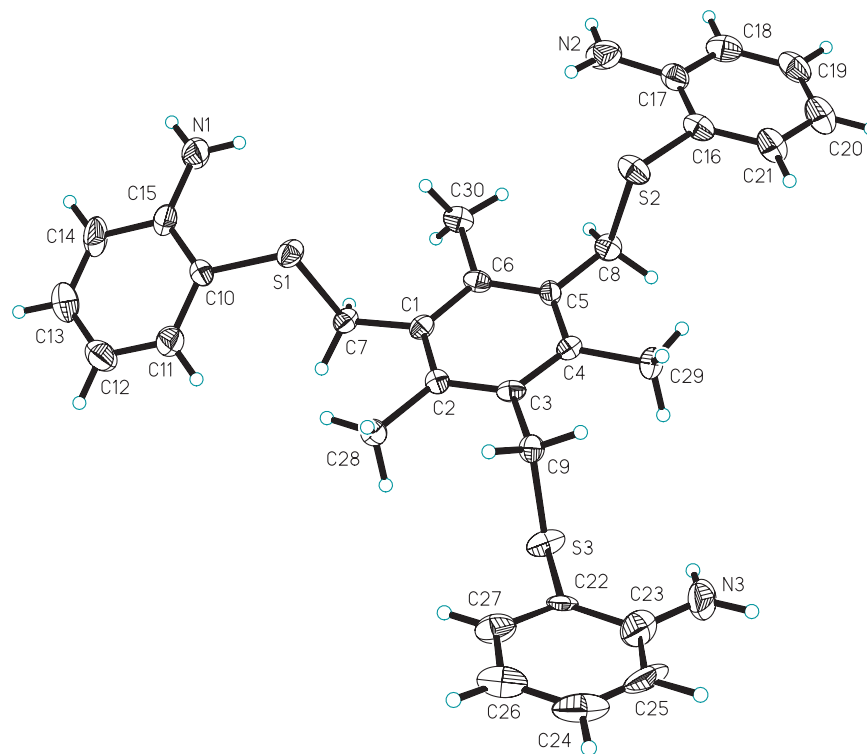
## 2. Results

The synthetic strategy is outlined in Scheme 1. The tripodal amine **2** was prepared by reacting **1** with 2-aminiothiophenol. The amine is obtained in white, crystalline form in 75% yield. It was characterized by elemental analyses, mass spectrum, infrared spectra,  $^1\text{H}$ ,  $^{13}\text{C}$  NMR, UV–vis absorption spectroscopy and X-ray crystal structure analysis. Receptors **3a–d** were synthesized by two routes (A and B). According to route B, 1 mmol of tripodal amine **2** was stirred with 3.2 mmol of aldehyde RCHO (**a–d**) (both taken in 9:1 acetonitrile:chloroform mixture), in the presence of 3–4 mg of zinc perchlorate. The color of the solution immediately changed to yellow and precipitate separated out in quantitative yield, upon addition of methanol. The absence of  $\text{Zn}^{2+}$  from the Schiff bases was confirmed by elemental analyses for all of them along with X-ray crystal structure analysis for **3a**. Keeping all other conditions same, the reaction was set up following route A, that is, in the absence of zinc perchlorate. The reactions were followed by thin layer chromatography, which showed that the reactions

did not go to completion even after stirring for 3 h and the presence of unreacted amine was seen. Extra amounts (1.5 mmol) of the aldehyde were added. No solid separated on its own on completion of the reactions and on addition of methanol only gummy materials separated out. The solvent was evaporated from these impure products and these were repeatedly recrystallized from chloroform–methanol mixture to get pure products in a very poor yield. Table 1 gives an account of the yields of the products by using both the routes.

**Table 1.** Comparison of yields of the compounds obtained through route A and B

Compound	Route A	Route B
<b>3a</b>	45%	89%
<b>3b</b>	53%	90%
<b>3c</b>	55%	96%
<b>3d</b>	50%	93%
<b>3e</b>	55%	—
<b>3f</b>	57%	—
<b>4</b>	—	77%



**Figure 1.** X-ray crystal structure of **2** and the labeling scheme used.

A  $^1\text{H}$  NMR spectrum of the tripodal amine **2** in  $\text{CDCl}_3$  was taken after adding 2 mg of  $\text{Zn}(\text{ClO}_4)_2$ , shaking and filtering the solution to remove the latter, most of which remains undissolved. It showed an upfield shift of  $\Delta\delta$  0.90 ppm only for the amine protons suggesting the formation of  $2 \cdot \text{Zn}(\text{ClO}_4)_2$  by coordination through amine nitrogens. The same shift has been found in a 1:1 complex of **2** with  $\text{Zn}(\text{ClO}_4)_2$ .<sup>14</sup> However,  $\text{Zn}^{2+}$  has not been found in the final imine products. This shows an initial participation and subsequent removal of  $\text{Zn}^{2+}$  from the Schiff bases. Quite interestingly, a synthetic approach using route B for the condensation of **2** with aldehydes **e–g** to form **3e–g** did not give useful results. Therefore, trials were made to synthesize these compounds by route A. Whereas, **3e–f** could be purified and characterized satisfactorily, the  $^1\text{H}$  NMR of **3g–i** showed a mixture of the Schiff base and the corresponding aldehyde and could not be obtained with analytical purity. Therefore, these are included only for their UV–vis spectral studies in solution and have been retained for comparison.

## 2.1. Spectroscopic and X-ray crystal data

The spectroscopic data for the tripodal amine **2** is fully interpreted and is in accordance with the structure. FAB-mass spectrum shows a clear molecular ion peak at 531. The  $^1\text{H}$  NMR spectrum of the compound shows one signal each for methyl, methylene and amine protons and one signal for each of the four aromatic protons of 2-aminothiophenol moiety. This shows that three arms of the tripodal ligand are equivalent and the amine has three-fold symmetry in the solution phase. The UV–vis spectrum of the ligand shows a band at  $\lambda_{\text{max}}$  315 nm in chloroform, which is attributed to an intraligand charge transfer transition in the compound.

The solid state structure of **2** is shown in Figure 1. The four aromatic rings are planar with maximum deviation of 0.04 Å for the central ring (ring A). The ring B (C10–C15), the ring C (C16–C21) and the ring D (C22–C27) are making dihedral angles 24.4(2), 14.8(2) and 21.1°(2) with the ring A, respectively. The torsion angles about S1–C7, S2–C8 and S3–C22 are all trans, being  $-166.9(4)$ ,  $-179.4(4)$  and  $-175.7(4)^\circ$ , respectively. Thus, the aromatic rings are almost parallel to each other. Three-fold symmetry of the tripodal amine, which was present in the solution phase, is lost due to the fact that three arms of the tripod have different orientations. Whereas rings B and C are above the plane of the central ring A, ring D is below this plane. Again two arms containing rings B and C apparently seem to be in the same orientation but on close inspection they too are not found to be so. Both the amine nitrogens N2 and N3 are *endo* pointing towards methyl carbons C29 and C30, respectively whereas N1 instead of being oriented towards methyl carbon C28 is inverted towards C30 and is *exo* with respect to C28. Thus, both N1 and N2 amine nitrogens are directed towards C30. There are intra- and inter-molecular H-bonding interactions found in the unit cell. The amine nitrogens are intra-molecularly H-bonded to the sulfur atoms in their respective arms (Table TI, Supplementary). Strong intermolecular H-bonding occurs between amine nitrogens N1 and N2. Both of them act as H-bond donor and acceptor towards each other. Weak intermolecular H-bonding interactions also occur between methylene carbons C7 and C9 and S1 and S3, respectively. The unit cell shows stacking down the *a* axis. The shortest  $\pi$ – $\pi$  distance is 3.65 Å between two symmetry related rings D which indicates a  $\pi$ – $\pi$  interaction and the next shortest distance is 4.93 Å between two symmetry related rings A (Fig. S1, Supplementary data).

Compounds **3a–f** are fully characterized and the absence of  $\text{Zn}^{2+}$  from the final products **3a–d** was confirmed by elemental analyses. The peaks in the range  $1622\text{--}1666\text{ cm}^{-1}$  show the presence of imine bond. In **3a** the OH stretching frequency has lowered and has overlapped with the C–H (aliphatic) and C–H (aromatic) stretching frequencies. This is, probably due to strong intramolecular H-bonding interactions between OH and the imine proton as found earlier in a similar compound by us.<sup>15</sup> In the  $^1\text{H}$  and  $^{13}\text{C}$  NMR spectra there were single peaks corresponding to methyl, methylene, imine protons and carbons and also for hydroxyl protons in **3a** which point towards a three-fold symmetry of the molecules being retained in the solution phase.

The X-ray crystal structure of **3a** formed by route B is shown in Figure 2. All seven aromatic rings are almost planar with maximum deviation of  $0.03\text{ \AA}$  for the central ring (ring A). One arm of the tripodal ligand is highly unsymmetrical with respect to the other two thus removing any threefold symmetry expected of the compound as found in the solution state. The rings B (C11–C16), C (C25–C30) and D (C39–C44) are making dihedral angles  $78.8(2)$ ,  $41.9(2)$  and  $88.2^\circ(2)$  with the ring A, respectively. Thus rings B and D are almost perpendicular to the central ring A but ring C is *gauche* to it. Similarly rings E (C18–C23) and G (C46–C51) are perpendicular (dihedral angles  $78.3$  and  $87.5^\circ$ , respectively) but ring F (C32–C37) is parallel (dihedral angle  $6.1^\circ$ ) with respect to ring A. The torsion angles about S1–C10 and S3–C38 are *anti*, being  $-170.0(2)$ , and  $-154.6(2)^\circ$ , respectively but around S2–C24 is *gauche*  $75.7(3)^\circ$ . This conformational analysis shows that the tripod is not in its fully extended form but one of its arms has folded up to make a loop having ring F parallel to ring A. This loop is stabilized by various intramolecular interactions (Table III, Supplementary) such as edge to edge  $\pi\cdots\pi$  interactions between the two rings A and F;  $\text{CH}_3\cdots\pi$  interaction between methyl carbon C7 and

ring F; H-bonding between methyl carbon C8 with O2 and S2; H-bonding between imine carbon C31 and O3 and H-bonding between phenylene carbon C29 and O3.

There are intra- and inter-molecular H-bonding interactions found in the unit cell. The hydroxyl oxygens O1 and O3 are acting as double H-bond donors to imine nitrogens N3, N1 and thioether sulfurs S3 and S1, respectively in the two extended arms. In the folded arm of the tripod however, O2 is having intramolecular H-bonding interactions only with imine nitrogen N2 but not to S2. The packing of the molecule in the unit cell has stacking down the *c* axis and shows weak intermolecular C–H $\cdots$ O and C–H $\cdots$ S type of H-bonding interactions. Hydroxyl oxygen O1 is acting as a triple H-bond acceptor from methylene carbon C10 and phenylene carbons C19 and C47. O2 and O3 accept H-bonds from C49 and C42, respectively while S2 and S3 acts as acceptors towards C50 and C17. Apart from these H-bonds, the molecules in the unit cell are held together by C–H $\cdots\pi$  interactions between methylene carbon C10 and ring G, face to face  $\pi\cdots\pi$  interactions between rings B and D and edge on edge  $\pi\cdots\pi$  interactions of ring B with F (C35 $\cdots$ C13) and of ring E with G (C48 $\cdots$ C20).

## 2.2. UV–vis spectral studies

The electronic absorption spectra of all the ligands **3a–i** have been studied in chloroform–acetonitrile mixture. The common UV–vis spectral feature of these compounds is an intense band in the range  $365\text{--}390\text{ nm}$ . This band was designated as an intraligand charge transfer transition involving imine chromophore.<sup>15–16</sup> The designation is based upon the fact that this band is absent in the tripodal amine **2** and is formed on Schiff base condensation. The time taken for the completion of reaction using the template, was established by UV–vis absorption spectroscopy. Time variable UV–vis spectra of the reaction mixtures, taken at a regular interval of 1 min, after the addition of RCHO to a

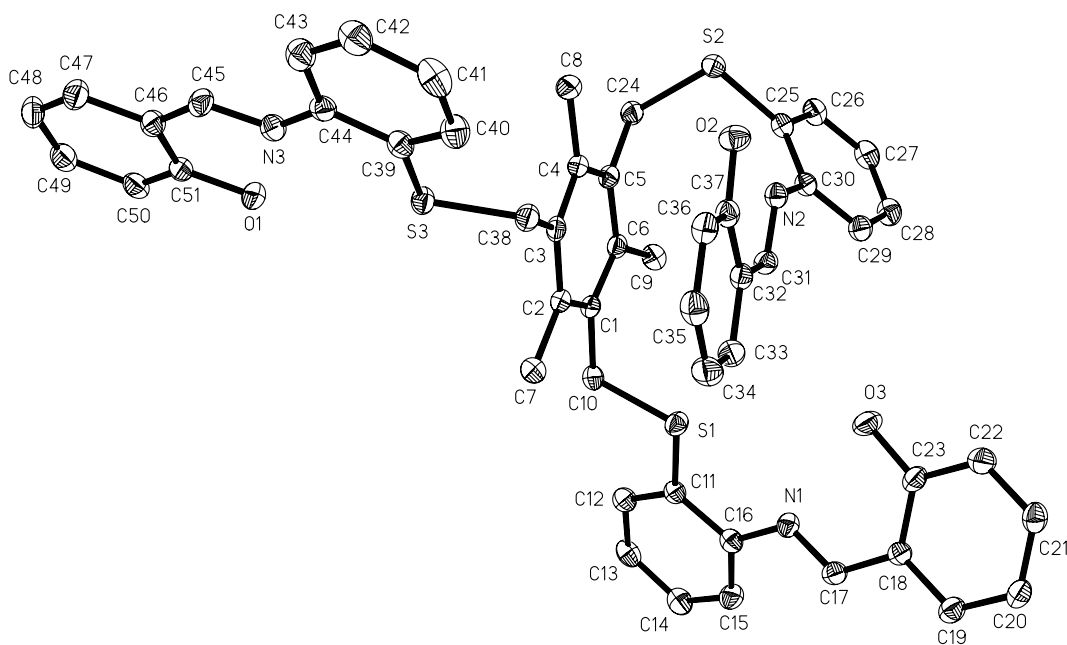
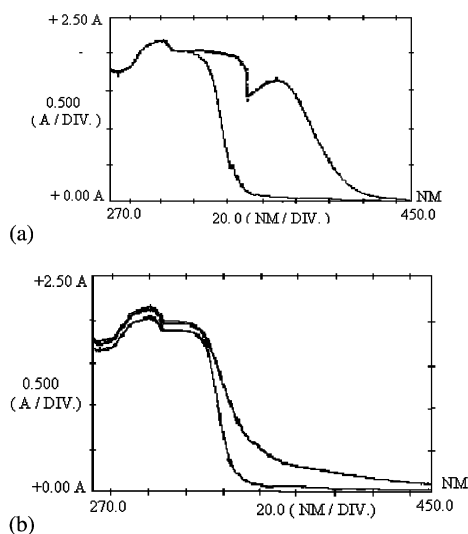


Figure 2. X-ray crystal structure of **3a** and the labeling scheme used, hydrogens have been omitted for the sake of clarity.



**Figure 3.** Time variable UV–vis spectra of the compounds **3e** and **3h** (a and b) taken during synthesis by route B. The appearance of imine band around 365 nm (a) shows an immediate condensation into Schiff bases. Whereas no such band appears in compounds **3g–i** (b), indicating failure of the reaction.

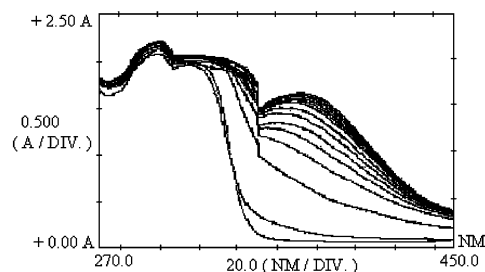
mixture of tripodal amine **2** and  $\text{Zn}(\text{ClO}_4)_2$  in chloroform–acetonitrile (9:1) showed the appearance of a new band at  $\lambda_{\text{max}}$  in between 365 and 390 nm (Fig. 3a). There is no variation in the  $\lambda_{\text{max}}$  and  $\epsilon_{\text{max}}$  values for these bands after 1 min for **3a–d** which means that the reaction immediately goes to completion. For compounds **3e–i** there is no change in the spectrum of the amine (**2**) and no new band appears in the above-mentioned range (Fig. 3b). This shows that for **3e–i** compounds the condensation is either not taking place or is occurring at an extremely slow rate in comparison to that for **3a–d**, even if  $\text{Zn}(\text{ClO}_4)_2$  is present in excess. This indicates that an additional binding site at the ortho position to the carbonyl group of the aromatic aldehyde, is the basic requirement for the reaction to follow route B. In the absence of this group, as in **3e–i** the reaction has no involvement of the  $\text{Zn}(\text{II})$  ion and is not facilitated by it. To further prove this point the reaction of **2** was attempted with benzaldehyde in the presence of  $\text{Zn}(\text{II})$ , but no reaction occurs.

### 2.3. Absence or presence of $\text{Zn}(\text{II})$

The presence of  $\text{Zn}(\text{II})$  in the amine complex and further its absence in the final Schiff base was checked by other experiments also besides the spectroscopic evidences provided above. Freshly prepared samples, of the complexes of  $\text{Zn}(\text{II})$  with amines **2**, **5** and **8** and their corresponding Schiff bases prepared by route B, were digested and the resulting solutions were tested qualitatively for  $\text{Zn}(\text{II})$ . These tests were done by using diphenylthiocarbazone<sup>17</sup> and by using atomic absorption spectroscopy. These tests showed all the amine complexes contained  $\text{Zn}(\text{II})$  whereas the Schiff bases had none. The  $\text{Zn}(\text{II})$  complexes of **2** and **8** have been reported by us but the complex with **5** is already known.<sup>18</sup> The absence of  $\text{Zn}(\text{II})$  from the corresponding Schiff base, strongly endorses initial participation and subsequent removal of the metal ion from the final product.

### 2.4. Synthesis of the Lariat compound **4**

These results encouraged us to try and use this templated synthesis to prepare a macrocycle ring by using a dialdehyde having another donor at position 2 with respect to the aldehyde groups. All attempts to synthesize the lariat coronand **4** in a pure form, by route A were unsuccessful, but by using  $\text{Zn}(\text{ClO}_4)_2$  a metal ion free product was obtained in a good yield and with very fast rate. On the addition of pyridine 2,6-diformylaldehyde to the stirring solution of  $2 \cdot \text{Zn}(\text{ClO}_4)_2$ , compound **4** separated out on the walls of round bottom flask after 10 min. The compound was characterized by spectroscopic methods. Molecular ion peak, required at  $m/z$  630, is present in very small relative abundance (Fig. S2, Supplementary). But various other peaks indicate the molecular ion to be the one suggested as **4**. For instance, peak with  $m/z$  ratio 662 may correspond to an ion  $[\text{M} + \text{methanol}]^+$ , 647 to  $[(\text{M} + \text{methanol}) - \text{CH}_3]^+$ , 615 to  $[(\text{M} - \text{CH}_3)]^+$ , 587 to  $[(\text{M} - 3 \times \text{CH}_3) + 2]^+$  and 463 to a  $[\text{m} + 2]^+$  ion formed after losing three methyl and the  $\text{SPhNH}_2$  groups. Elemental analysis of the dried sample confirms the formula to be  $\text{C}_{37}\text{H}_{34}\text{N}_4\text{S}_3$ . However, it did not show any methanol present. The IR spectrum of the compound shows a  $\nu_{\text{C}=\text{N}}$  band at  $1624 \text{ cm}^{-1}$ . However, no band due to  $\nu_{\text{N-H}}$  was seen in the range  $3000\text{--}3500 \text{ cm}^{-1}$ . It seems likely that as a result of strong H-bonding the N–H vibrations are shifted to still lower energies and the intensities are also reduced<sup>19</sup> to merge with the CH stretching bands which are seen in the compound at  $3051$  and  $2887 \text{ cm}^{-1}$ . However, a NH bending frequency is found at  $1572 \text{ cm}^{-1}$  indicating the presence of a free amine group. Both  $^1\text{H}$  and  $^{13}\text{C}$  NMR are fully characterized. The  $^1\text{H}$  NMR has a broad signal for the methyl protons in the range  $\delta$  2.29–2.33 that shows slight inequivalence in their chemical environment. However, there is only one signal for methyl carbons in the  $^{13}\text{C}$  NMR which may be a result of all the methyl groups being in the plane of the central benzene ring. There are two signals for methylene protons in  $^1\text{H}$  and  $^{13}\text{C}$  NMR. Appearance of one signal each, at the expected chemical shift values, for  $\text{NH}_2$  protons, imine protons, meta and para hydrogens of the pyridine moiety, and absence of any signal due to aldehyde protons clearly indicate that two arms of the tripodal amine **2** have undergone condensation with the dialdehyde and one arm remains as free amine forming the lariat compound **4**. This successful synthesis, which takes place only in the presence of  $\text{Zn}^{2+}$ , speaks volumes about the important role played by the latter. The fast rate at which this reaction is completed in the presence



**Figure 4.** Time variable UV–vis spectra of **4** taken by mixing solutions of the amine **2** and  $\text{Zn}(\text{ClO}_4)_2$  with 2,6-diformylpyridine. A gradual appearance of the imine band at 364 nm signifies the formation of the Schiff base containing lariat compound **4**.

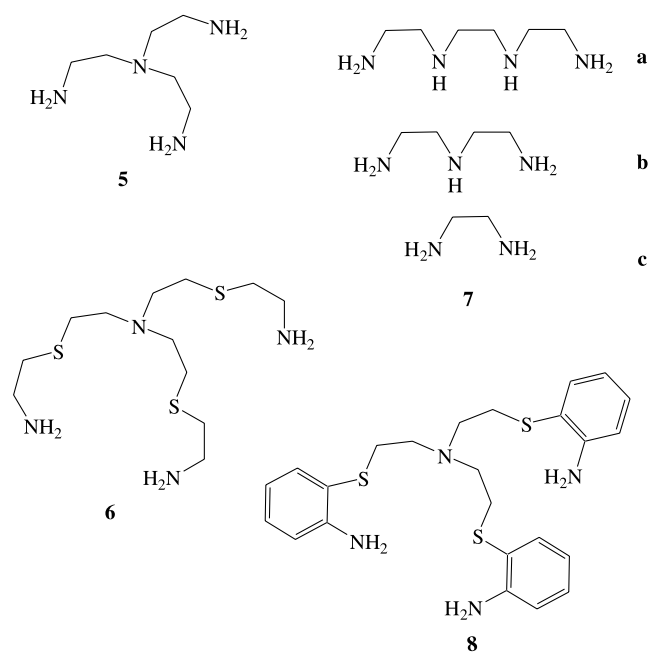
of  $\text{Zn}^{2+}$  may be appreciated from the time variable UV–vis spectrum taken on addition of the 2,6-diformaldehyde-pyridine to a solution of amine **2** and  $\text{Zn}(\text{ClO}_4)_2$  (Fig. 4). The procedure gives a very fast and efficient method for the preparation of similar lariat compounds. Unfortunately compound **4** once separated, was found to be insoluble in all common solvents except for dimethylsulfoxide and has not been crystallized as yet for studying with X-ray diffraction.

## 2.5. Role of anions in the reaction

To decide the role played by the anion in the templated reaction the reactions were repeated by reacting **2** with aldehydes **a–d** in the presence of  $\text{ZnCl}_2$ . These solutions were mixed and their time variable UV–vis spectra were taken. No new band emerged in the spectra showing failure of the reaction or a drastic decrease in the reaction rates. In order to check whether it was the zinc ion or the perchlorate which was acting as the template, another similar experiment was set up where  $\text{Zn}(\text{ClO}_4)_2$  was substituted by  $\text{NaClO}_4$  and reaction of **2** was performed with salicylaldehyde **a**, followed by the UV–vis spectral studies. Absence of any new band around 365 nm again showed that the reaction had failed and confirmed the role played by the  $\text{Zn}(\text{II})$  ion.

## 2.6. Type of amine used

To see the effect of the type of amine used for condensation, similar reactions were tried with other aliphatic di- and tripodal amines **5–7** (Scheme 2). The reactions of these amines with salicylaldehyde, using both routes A and B were performed. It was observed that the reactions take place at equal rates and give the desired products with comparable yields and purity (Fig. 5). The reaction with aromatic tripodal amine **8** with salicylaldehyde, however is highly improved, as already reported<sup>15</sup> by adopting route B,



Scheme 2.

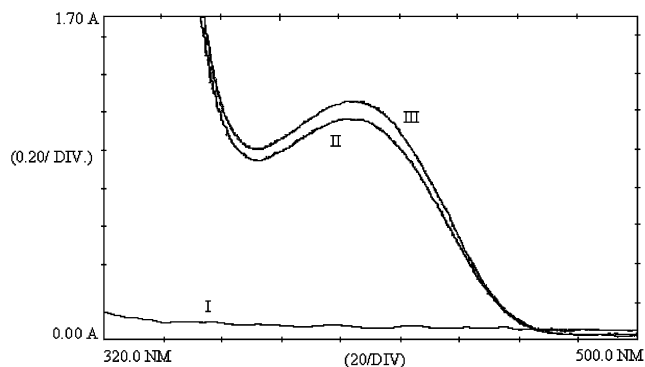


Figure 5. UV–vis spectra of (I) pure amine **7b** (II) amine **7b** and salicylaldehyde (III) amine **7b**, salicylaldehyde and  $\text{Zn}(\text{ClO}_4)_2$ .

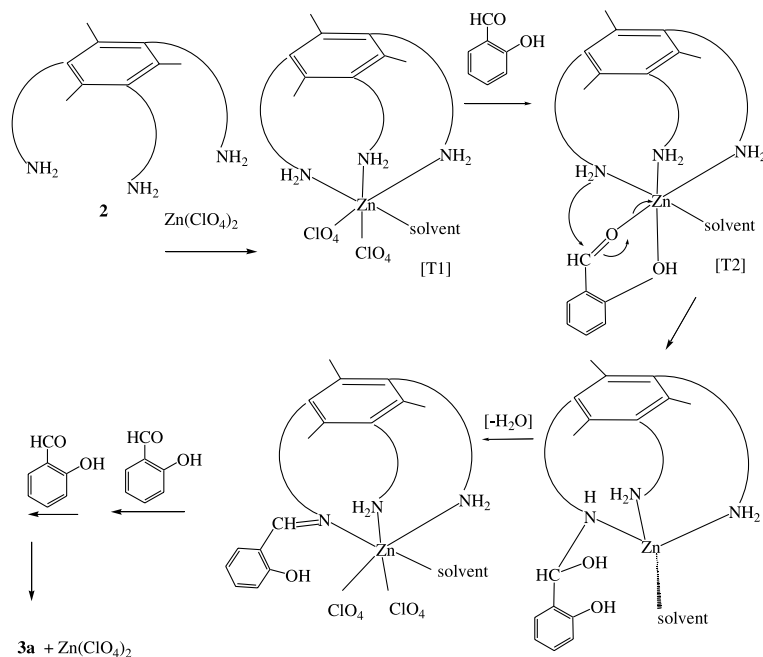
just like that seen in the case of amine **2**. From this it seems that  $\text{Zn}(\text{II})$  is only helpful in the case of aromatic amines and with aliphatic amines the reaction is already very fast. This is expected because for aromatic amines, the lone pair of N is involved in resonance with aromatic ring and is less available to attack the carbonyl group. When the aromatic amines are organized by  $\text{Zn}(\text{II})$  ion the electron density is greater on  $\text{NH}_2$  and its nucleophilicity is improved.

Further efforts were made to form Lariat compounds similar to **4** by reacting 2,6-diformaldehyde-pyridine with amines **5**, **6**, **7a** and **8** using route B. The reaction product with **5** was insoluble in all commonly used solvents and could not be investigated but the products with **6–8** were soluble in dimethylsulfoxide. The  $^1\text{H}$  NMR of these products showed that compounds were either not formed or were formed partially. Compound **7** is a very flexible amine containing both primary and secondary amine groups whereas **5**, **6** and **8** contain primary amine groups but are attached to a N as an anchor in the tripod. It is well known that such tripodal amines are very flexible due to facile inversion<sup>2</sup> at the pyramidal N of the anchor. Therefore, these amines either fail to provide two adjacent primary amine groups as in **7** or do not provide them with the requisite spacing (**5**, **6**, **8**) for simultaneous condensation with a dialdehyde. This shows that a certain amount of rigidity is required in the tripodal amine to provide the correct spacing for double condensation.

## 3. Discussion

A tentative mechanism for the zinc-mediated condensation of the tripodal ligands is suggested in Scheme 3. The mechanism proposed for the template synthesis is analogous to a large extent with that involved in the synthesis of metal ion complexes of imine containing polydentate ligands.<sup>20</sup> The syntheses of these complexes requires intramolecular condensation reactions between 2-aminocarbonyl or coordinated pyruvate<sup>21</sup> with a polyamine which is already coordinated to a metal ion ( $\text{Co}^{3+}$ ). Along similar lines, it is proposed here that the addition of  $\text{Zn}(\text{ClO}_4)_2$  to the tripodal amine **2** forms a complex of  $\text{Zn}^{2+}$ , where **2** is coordinating through all of its primary amine groups. The solution state  $^1\text{H}$  NMR of amine **2** containing zinc perchlorate, provides evidence for this kind of binding. Two other coordinating positions around zinc are occupied





Scheme 3.

by perchlorate ions to give [T1]. This complex is thus analogous to the  $\text{Co}(\text{III})\text{Cl}_3$  complex of a polyamine. When an aldehyde having a donor group at position-2 with respect to the carbonyl group, for example, **a–d** is added, this donor group coordinates to  $\text{Zn}(\text{II})$  by substituting the perchlorate ions. This step explains the crucial role played by the labile perchlorate ion instead of chloride ions. The chloride ion has been shown to remain coordinated to zinc ion during complexation with podands<sup>22</sup> and does not easily leave  $\text{Zn}(\text{II})$  ion like perchlorate ion.<sup>23</sup> Zinc(II) also seems to play a role in increasing the electrophilic character of the carbonyl carbon. As zinc is a Lewis acid that is well known to polarize a group to which it binds,<sup>24</sup> an electrophilic center is created on the carbonyl carbon and hence nucleophilic attack by a coordinated amine nitrogen can take place readily at this carbon. Such polarization by  $\text{Zn}(\text{II})$  gives rise to the next intermediate [T2] as shown in Scheme 3. This coordination of  $\text{Zn}(\text{II})$  by the carbonyl oxygen and adjacent donor atom present at position 2 with respect to the carbonyl group, forms a five (**b–d**) or six (**a**) membered chelate ring with the metal ion in [T2]. The inherent stability associated with these chelate rings and also the close proximity of the carbonyl group which may be easily attacked by a bound amine group, explains for the requirement for a donor at this position to the desired results. Once the carbonyl carbon is activated, the reaction is followed by a nucleophilic attack by the amine nitrogen on this carbon. Such a phenomenon has long been thought to occur in carboxypeptidases. During the direct hydrolysis of zinc ester or amide substrate complex, zinc acts as Lewis acid on the carbonyl group of the amide or the ester while making water attack it as well<sup>24</sup> and once the water attacks the carbonyl group  $\text{Zn}(\text{II})$  is released. Along the same lines it is proposed that when the amine nitrogen attacks the activated electrophilic carbonyl carbon of the aldehyde to give intramolecular condensation reaction, zinc ion is detached from that particular aldehyde. Subsequent dehydration from [T2] will form the desired imine bond. The

detached  $\text{Zn}(\text{II})$  ion can coordinate another 2-substituted aldehyde and the process is repeated till the condensation is complete for all three arms of the tripod. Now the nitrogens in the newly formed receptor **3** will have changed from  $\text{sp}^3$ -hybridized primary amine to  $\text{sp}^2$ -hybridized planar imine nitrogens. These  $\text{sp}^2$  nitrogens have smaller radii and more directional lone pairs and in the present case are attached to bulky end groups by the rigid imine double bond. Hence, these nitrogens are less flexible and are unable to complex the small zinc ion, which is eventually expelled to yield metal ion free receptor **3**.

### 3.1. Role of $\text{Zn}(\text{II})$

The effective role played by zinc here in this manner depends on some of its well known structural and thermodynamic properties<sup>24</sup> like:

- Good Lewis acidity which is only smaller to that of  $\text{Cu}(\text{II})$  among all the divalent transition metal ions. This Lewis acidity helps to generate a reactive electrophilic center.
- Fast ligand exchange around  $\text{Zn}(\text{II})$  allows rapid reorganization of atoms. Fast reactions are more easily carried out by metal ions, which while polarizing groups, can take up and release molecules from their coordination spheres rapidly. The rearrangement of groups on  $\text{Zn}^{2+}$  is usually fast unlike that of other metal ions.
- Coordination geometry around  $\text{Zn}(\text{II})$  is very flexible.

The ease with which coordinated nucleophiles can attack reactive centers within a metal complex has been considered for a long time.<sup>25</sup> A similar role has been played by zinc (II) in the conversion of organonitriles into carboxamides in the presence of  $\text{ZnX}_2/\text{ketoimine}$ <sup>26</sup> and has also been suggested to occur in the theoretical study on  $\text{Zn}$ -mediated hydration of nitriles on heterogenous catalysts.<sup>27</sup> Syntheses of carboxamide with concomitant regeneration of the

Zn(II)/ketoxime in the former case strengthens the pathway suggested herein.

#### 4. Conclusions

Schiff base condensation reactions have been performed by reacting a tripodal aromatic amine with aldehydes having another donor atom at position 2 with respect to the carbonyl group, in the presence of zinc perchlorate as template. The facile one-pot template synthesis offers a viable route to tripodands because of the fast rate, high purity and quantitative yield. More important, the absence of the template ion in the final Schiff base saves the need of removing the template ion to get a metal free compound. It has been seen that the rigidity of the amine being used and the presence of another donor atom adjacent to the carbonyl group are the two requirements for the reaction to proceed in this manner. The reactions open a new pathway for the synthesis of lariat coronands using environment friendly zinc salt as catalyst.

#### 5. Experimental

##### 5.1. General

Melting points are uncorrected. Most chemicals were purchased from Aldrich Co. and used as received without further purification. Organic solvents were purified by standard procedures. The elemental analyses and FAB mass spectra were done at RSIC at Central Drug Research Institute, Lucknow, India. The  $^1\text{H}$  and  $^{13}\text{C}$  NMR were taken on a 200 MHz Bruker and 300 MHz JEOL Instruments. TMS was used as a standard reference. IR were recorded on a PYE Unicam IR spectrometer for the compounds in the solid state as KBr discs or as neat samples. UV–vis absorption spectra were taken on a Shimadzu Pharmaspec UV-1700 UV–vis spectrophotometer. All compounds were obtained as yellow solids and their % yields are given in Table 1.

**5.1.1. Compound 2.** Tripodal amine **2** was prepared by taking 1.00 g. of  $\text{K}_2\text{CO}_3$  in dry acetonitrile along with 375 mg (0.32 ml, 3 mmol) of 2-aminothiophenol. The reaction mixture was refluxed for 20 min and then 398 mg (1 mmol) of tribromide **1** was carefully added to it. The reflux was continued for 8 h and progress was monitored by TLC. Upon completion of the reaction  $\text{K}_2\text{CO}_3$  was filtered off and acetonitrile evaporated. The crude product was recrystallized from chloroform-methanol solvent mixture to get 400 mg of pure white solid material. Yield 75%. Mass spectrum (FAB):  $m/z$  531 ( $\text{M}^+$ ); UV–vis ( $\lambda_{\text{max}}$  (nm),  $\epsilon$  ( $\text{dm}^3 \text{cm}^{-1} \text{mol}^{-1}$ )) 315 (11630); IR (KBr,  $\text{cm}^{-1}$ ) 1604 (s), 2924 (s), 2854 (s), 3305 (w), 3410 (w);  $^1\text{H}$  NMR (200 MHz,  $\text{CDCl}_3$ )  $\delta$ : 2.38 (s, 9H,  $-\text{CH}_3$ ), 4.01 (s, 6H,  $-\text{CH}_2$ ), 4.38 (s, 6H,  $-\text{NH}_2$ ), 6.65–6.76 (m, 6H, Ar), 7.14 (t, 3H, Ar,  $J=4.0$  Hz), 7.35 (d, 3H, Ar,  $J=6.4$  Hz);  $^{13}\text{C}$  NMR (75 MHz,  $\text{CDCl}_3$ )  $\delta$ : 15.8 ( $-\text{CH}_3$ ), 35.6 ( $-\text{CH}_2$ ), 118.2 (Ar), 114.9 (Ar), 118.6 (Ar), 129.9 (Ar), 132.3 (Ar), 135.8 (Ar), 136.1 (Ar), 148.5 (Ar); CHN Anal. Calcd  $\text{C}_{30}\text{H}_{33}\text{N}_3\text{S}_3$ , C=67.75, H=6.25, N=7.90; found C=67.49, H=6.13, N=7.66.

**5.1.2. Compound 3a.** This compound was prepared by

stirring tripodal amine **2** (535 mg, 1.0 mmol) along with salicylaldehyde (390 mg, 3.2 mmol) in the presence of 3–4 mg of zinc perchlorate taken in acetonitrile–chloroform (9:1) solvent mixture. The color of the solution changed immediately to yellow and precipitate separated in quantitative yield (750 mg) upon addition of methanol. These precipitates were filtered and dried. The compound could also be prepared by taking the same amounts of tripodal amine (535 mg, 1.0 mmol) and salicylaldehyde (390 mg, 3.2 mmol) in the same solvent mixture with no zinc perchlorate in it. The solution was stirred but the reaction never went to completion as checked by TLC, which showed the presence of unreacted amine even after 3 h. Therefore to completely convert unreacted amine to Schiff base a second portion of salicylaldehyde (183 mg, 1.5 mmol) was added and the reactants were stirred for another h. No solid separated out on adding methanol. On evaporation of the solvent a crude product separated out. Repeated recrystallizations from chloroform-methanol gave rise to pure compound (380 mg). Mp=145 °C; FAB-MS [ $\text{M}^+$ ]=844 (base peak); UV–vis ( $\lambda_{\text{max}}$  (nm),  $\epsilon$  ( $\text{dm}^3 \text{cm}^{-1} \text{mol}^{-1}$ )) 365 (1529), 293 (1921); IR (KBr,  $\text{cm}^{-1}$ ) 1666 (m), 3164 (br);  $^1\text{H}$  NMR (200 MHz,  $\text{CDCl}_3$ ):  $\delta$  2.01 (s,  $-\text{CH}_3$ , 9H), 3.72 (s,  $-\text{CH}_2$ , 6H); 6.87–7.02 (m, Ar, 6H); 7.12–7.42 (m, Ar, 18H); 8.43 (s,  $-\text{CH}=\text{N}$ , 3H); 13.16 (s,  $-\text{OH}$ , 3H);  $^{13}\text{C}$  NMR (75 MHz,  $\text{CDCl}_3$ ):  $\delta$  15.6 ( $-\text{CH}_3$ ); 33.41 ( $-\text{CH}_2$ ); 117.3 (Ar); 118.1 (Ar); 118.8 (Ar); 119.4 (Ar); 127.3 (Ar); 130.3 (Ar); 131.2 (Ar); 132.4 (Ar); 133.0 (Ar); 136.3 (Ar); 147.9 (Ar); 161.1 (Ar); 161.7 ( $\text{CH}=\text{N}$ ); Anal. Calcd  $\text{C}_{51}\text{H}_{45}\text{N}_3\text{O}_3\text{S}_3$ , C 72.57; H 5.37; N 4.98; found C 72.73; H 5.19; N 5.06.

**5.1.3. Compound 3b.** This compound was prepared (685 mg), using the same methods as adopted for **3a** except that pyrrole-2-formaldehyde (304 mg, 3.2 mmol) was taken instead of salicylaldehyde. Mp=230 °C; FAB-MS [ $\text{M}^+$ ]=763 (base peak); UV–vis ( $\lambda_{\text{max}}$  (nm),  $\epsilon$  ( $\text{dm}^3 \text{cm}^{-1} \text{mol}^{-1}$ )) 372 (1647), 301 (2203); IR (KBr,  $\text{cm}^{-1}$ ) 1656 (m), 3409 (m), 1610 (s);  $^1\text{H}$  NMR (200 MHz,  $\text{CDCl}_3$ ):  $\delta$  2.39 (s,  $-\text{CH}_3$ , 9H), 4.05 (s,  $-\text{CH}_2$ , 6H); 6.25 (d, Ar, 3H,  $J=4$  Hz); 6.65 (d, Ar, 3H,  $J=4$  Hz); 6.89 (s,  $-\text{NH}$ , 3H); 6.97 (t, Ar, 3H,  $J=4$  Hz); 7.07–7.26 (m, Ar, 9H); 7.35–7.39 (m, Ar, 3H); 8.15 (s,  $-\text{CH}=\text{N}$ , 3H);  $^{13}\text{C}$  NMR (75 MHz,  $\text{CDCl}_3$ ):  $\delta$  15.8 ( $-\text{CH}_3$ ); 33.1 ( $-\text{CH}_2$ ); 110.3 (Ar); 111.3 (Ar); 117.1 (Ar); 118.1 (Ar); 123.7 (Ar); 125.8 (Ar); 126.5 (Ar); 127.5 (Ar); 130.7 (Ar); 131.3 (Ar); 132.7 (Ar); 136.4 (Ar); 149.3 ( $\text{CH}=\text{N}$ ); Anal. Calcd  $\text{C}_{45}\text{H}_{42}\text{N}_6\text{S}_3$ , C 70.83; H 5.55; N 11.01; found C 70.62; H 5.33; N 11.36.

**5.1.4. Compound 3c.** This compound was also prepared (780 mg), using the same method as above except that thiophene-2-formaldehyde (358 mg, 3.2 mmol) was taken instead of salicylaldehyde. Mp=200 °C; FAB-MS [ $\text{M}^+$ ]=814(70); UV–vis ( $\lambda_{\text{max}}$  (nm),  $\epsilon$  ( $\text{dm}^3 \text{cm}^{-1} \text{mol}^{-1}$ )) 375 (1804), 317 (2076); IR (KBr,  $\text{cm}^{-1}$ ) 1662(s);  $^1\text{H}$  NMR (200 MHz,  $\text{CDCl}_3$ ):  $\delta$  2.35 (s,  $-\text{CH}_3$ , 9H), 4.03 (s,  $-\text{CH}_2$ , 6H); 6.99 (m, Ar, 3H); 7.11 (t, Ar, 3H,  $J=4.0$  Hz); 7.21 (t, Ar, 3H,  $J=3.2$  Hz); 7.42–7.49 (m, Ar, 12H); 8.42 (s,  $-\text{CH}=\text{N}$ , 3H);  $^{13}\text{C}$  NMR (75 MHz,  $\text{CDCl}_3$ ):  $\delta$  16.0 ( $-\text{CH}_3$ ); 33.7 ( $-\text{CH}_2$ ); 118.4 (Ar); 126.2 (Ar); 126.9 (Ar); 127.6 (Ar); 130.7 (Ar); 131.4 (Ar); 132.3 (Ar); 136.6 (Ar); 142.8 (Ar); 150.9 (Ar); 152.9 ( $\text{CH}=\text{N}$ ); Anal. Calcd  $\text{C}_{45}\text{H}_{39}\text{N}_3\text{S}_6$ , C 66.38; H 4.83; N 5.16; found C 66.45; H 4.57; N 5.30.

**5.1.5. Compound 3d.** Prepared as above (745 mg) except that pyridine-2-formaldehyde (342 mg, 3.2 mmol) was taken instead of salicylaldehyde. Mp=140 °C; FAB-MS [ $M^+$ ]=799 (60), [ $M+1$ ]<sup>+</sup>=800(75), UV-vis ( $\lambda_{\max}$  (nm),  $\epsilon$  (dm<sup>3</sup> cm<sup>-1</sup> mol<sup>-1</sup>)) 344 (1450), 292 (2020); IR (KBr, cm<sup>-1</sup>): 1623 (s); <sup>1</sup>H NMR (200 MHz, CDCl<sub>3</sub>):  $\delta$  2.46 (s, -CH<sub>3</sub>, 9H), 4.11 (s, -CH<sub>2</sub>, 6H); 7.07–7.12 (m, Ar, 3H); 7.24–7.44 (m, Ar, 12H); 7.60 (d, Ar, 3H,  $J=4$  Hz); 8.28 (d, Ar, 3H,  $J=8$  Hz); 8.53 (s, -CH=N, 3H); 8.68 (d, Ar, 3H,  $J=6$  Hz); <sup>13</sup>C NMR (75 MHz, CDCl<sub>3</sub>):  $\delta$  16.0 (-CH<sub>3</sub>); 33.0 (-CH<sub>2</sub>); 117.1 (Ar); 122.1 (Ar); 125.2 (Ar); 126.4 (Ar); 127.1 (Ar); 127.5 (Ar); 131.1 (Ar); 133.6 (Ar); 136.6 (Ar); 136.9 (Ar); 149.0 (Ar); 149.5 (Ar); 154.5 (Ar); 160.3 (CH=N); Anal. Calcd C<sub>45</sub>H<sub>42</sub>N<sub>6</sub>S<sub>3</sub>, C 70.83; H 5.55; N 11.01; found C 70.95; H 5.43; N 11.21.

**5.1.6. Compound 3e.** Attempts to synthesize this compound through zinc mediated template synthesis were not successful, so this compound was prepared by taking tripodal amine **2** (535 mg, 1.0 mmol) in dry acetonitrile along with pyridine-3-formaldehyde (482 mg, 4.5 mmol). Upon completion of reaction the solvent was evaporated and the crude product was purified by repeated recrystallization from chloroform methanol solvent mixture to give 440 mg of a yellow solid product. Mp=130 °C; FAB-MS [ $M^+$ ]=799; UV-vis ( $\lambda_{\max}$  (nm),  $\epsilon$  (dm<sup>3</sup> cm<sup>-1</sup> mol<sup>-1</sup>)) 344 (1579), 295 (2109); IR (KBr, cm<sup>-1</sup>) 1624 (s); <sup>1</sup>H NMR (200 MHz, CDCl<sub>3</sub>):  $\delta$  2.40 (s, -CH<sub>3</sub>, 9H), 4.06 (s, -CH<sub>2</sub>, 6H); 6.95–6.99 (m, Ar, 3H); 7.19–7.45 (m, Ar, 12H); 8.29 (d, Ar, 3H,  $J=8.0$  Hz); 8.39 (s, -CH=N, 3H); 8.65 (d, Ar, 3H,  $J=3.6$  Hz); 8.94 (s, Ar, 3H); <sup>13</sup>C NMR (75 MHz, CDCl<sub>3</sub>):  $\delta$  15.9 (-CH<sub>3</sub>); 33.1 (-CH<sub>2</sub>); 117.8 (Ar); 123.8 (Ar); 126.5 (Ar); 126.9 (Ar); 127.8 (Ar); 131.2 (Ar); 131.7 (Ar); 133.0 (Ar); 135.0 (Ar); 136.8 (Ar); 149.9 (Ar); 151.1 (Ar); 152.1 (Ar); 157.0 (CH=N); Anal. Calcd C<sub>48</sub>H<sub>42</sub>N<sub>6</sub>S<sub>3</sub>, C 72.15; H 5.30; N 10.52; found C 72.30; H 5.42; N 10.27.

**5.1.7. Compound 3f.** This compound was also prepared by the same method as that of **3e** except that pyridine-4-formaldehyde (482 mg, 4.5 mmol) was taken instead of pyridine 3 formaldehyde. 455 mg of yellow solid compound were obtained. Mp=190 °C; FAB-MS [ $M^+$ ]=799 (70), [ $M+1$ ]<sup>+</sup>=800(75), UV-vis ( $\lambda_{\max}$  (nm),  $\epsilon$  (dm<sup>3</sup> cm<sup>-1</sup> mol<sup>-1</sup>)) 376 (1531), 296 (2143); IR (KBr, cm<sup>-1</sup>) 1622 (s); <sup>1</sup>H NMR (200 MHz, CDCl<sub>3</sub>):  $\delta$  2.39 (s, -CH<sub>3</sub>, 9H), 4.06 (s, -CH<sub>2</sub>, 6H); 7.01 (d, Ar, 3H,  $J=6.6$  Hz); 7.24–7.32 (m, Ar, 6H); 7.43 (d, Ar, 3H,  $J=6.0$  Hz); 7.74 (d, Ar, 6H,  $J=5.0$  Hz); 8.35 (s, -CH=N, 3H); 8.72 (d, Ar, 6H,  $J=4.6$  Hz); <sup>13</sup>C NMR (75 MHz, CDCl<sub>3</sub>):  $\delta$  15.9 (-CH<sub>3</sub>); 33.1 (-CH<sub>2</sub>); 117.7 (Ar); 122.4 (Ar); 126.5 (Ar); 127.4 (Ar); 131.1 (Ar); 133.3 (Ar); 136.8 (Ar); 142.5 (Ar); 149.4 (Ar); 150.5 (Ar); 157.8 (CH=N); Anal. Calcd C<sub>48</sub>H<sub>42</sub>N<sub>6</sub>S<sub>3</sub>, C 72.15; H 5.30; N 10.52; found C 72.41; H 5.49; N 10.63.

**5.1.8. Compound 4.** This compound was prepared by stirring tripodal amine **2** (535 mg, 1.0 mmol) along with pyridine 2,6-diformaldehyde (135 mg, 1.0 mmol) in the presence of 3–4 mg of zinc perchlorate taken in acetonitrile–chloroform (9:1) solvent mixture. After 10 min of stirring the product separated out on the walls of round bottom flask. The precipitates were filtered, washed with methanol and then dried. Yield 485 mg, Mp=175 °C; IR=1624 cm<sup>-1</sup> (-CH=N-); FAB-MS=662 (2), 647 (2), 615

(3), 587 (7), 463 (26); UV-vis ( $\lambda_{\max}$  (nm),  $\epsilon$  (dm<sup>3</sup> cm<sup>-1</sup> mol<sup>-1</sup>)) 364 (1570), 301 (2221); IR (KBr, cm<sup>-1</sup>) 1624(s), 1572 (s), 2887 (w), 3051 (w); <sup>1</sup>H NMR (200 MHz, DMSO):  $\delta$  2.29–2.33 (-CH<sub>3</sub>, 9H), 3.95 (s, -CH<sub>2</sub>, 2H); 4.08 (s, -CH<sub>2</sub>, 4H); 5.32 (s, -NH<sub>2</sub>, 2H); 6.50 (t, Ar, 1H,  $J=6.2$  Hz); 6.73 (d, Ar, 1H,  $J=4.5$  Hz); 7.04 (t, Ar, 1H,  $J=6.0$  Hz); 7.16–7.47 (m, Ar, 5H); 7.49–7.51 (m, Ar, 2H); 8.24–8.29 (m, Ar, 2H); 8.58 (s, Ar, 1H); 8.68 (d, Ar, 2H,  $J=1.5$  Hz); 8.99 (s, CH=N, 2H); <sup>13</sup>C NMR (75 MHz):  $\delta$  15.7 (-CH<sub>3</sub>), 32.1, 34.8 (-CH<sub>2</sub>), 114.6 (Ar); 117.0 (Ar); 118.2 (Ar); 124.4 (Ar); 126.6 (Ar); 127.4 (Ar); 129.7 (Ar); 132.1 (Ar); 135.0 (Ar); 135.2 (Ar); 135.7 (Ar); 139.7 (Ar); 149.5 (Ar); 150.9 (Ar); 152.3 (Ar), 158.5 (CH=N); Anal. Calcd C<sub>37</sub>H<sub>34</sub>N<sub>4</sub>S<sub>3</sub>, C 70.44; H 5.43; N 8.88; found C 70.12; H 5.20; N 8.64.

## 5.2. UV-vis absorption studies

To carry out UV-vis spectral studies, a 10 ml (0.5 × 10<sup>-3</sup> M) solution of amine **2** containing 2–3 mg of Zn(ClO<sub>4</sub>)<sub>2</sub> was prepared in chloroform–acetonitrile (1:9) mixture and its absorption spectrum was taken. Then separately different solutions were prepared in 10 ml measuring flask by taking 1 ml of amine **2** solution (0.5 × 10<sup>-2</sup> M, CHCl<sub>3</sub>) and Zn(ClO<sub>4</sub>)<sub>2</sub> along with 1 ml of different aldehydes RCHO (1.6 × 10<sup>-2</sup> M, CH<sub>3</sub>CN). The volume of each of these solutions was made up to 10 ml by adding additional CH<sub>3</sub>CN, so that the concentrations of amine and the aldehyde in the final solutions became 0.5 × 10<sup>-3</sup> M and 1.6 × 10<sup>-3</sup> M, respectively in chloroform–acetonitrile (1:9) solvent mixture. For making the solution for **4**, 1 ml of pyridine 2,6-diformaldehyde (0.5 × 10<sup>-2</sup> M, CH<sub>3</sub>CN) was taken along with the solution of 1 ml amine **2** (0.5 × 10<sup>-2</sup> M, CHCl<sub>3</sub>) and Zn(ClO<sub>4</sub>)<sub>2</sub>. Then the total volume of this solution was made 10 ml by adding additional amounts of acetonitrile. The absorption spectra of these solutions were recorded immediately after mixing the aldehyde and subsequently at a regular intervals of 1 min.

## 5.3. Qualitative analysis of Zn(II)

For testing Zn(II) qualitatively, from the complexes of the amines **2**, **5** and **8** with Zn(II) and their corresponding Schiff bases with salicylaldehyde prepared by route B, 25–30 mg of the freshly prepared compounds were digested by boiling with nitric acid. The liquid was evaporated in a small china dish and the residues were redissolved in 1 M HCl and filtered if necessary. The filtrates were tested for zinc by using a solution of diphenylthiocarbazon and by using atomic absorption method.

## 5.4. X-ray crystallography

The data for both the crystals were collected on a Nonius kappa CCD2000 with graded mirror, using Cu K $\alpha$  radiation (1.5418 Å). Table 2 gives the details of data collection and refinement for both the compounds. Both structures were solved by direct methods and subsequent difference Fourier Syntheses and refined by full-matrix least squares on  $F^2$  with SHELXLTL.<sup>28</sup> Lorentz and polarization corrections were applied but no absorption correction was applied. On anisotropic refinement of **2**, one of the phenyl rings (ring D as defined above) and its amine nitrogen N3 showed disorder in terms of abnormal bond distances and high

**Table 2.** Crystal data and refinement parameters

	(2)	(3a)
Empirical formula	C <sub>30</sub> H <sub>33</sub> N <sub>3</sub> S <sub>3</sub>	C <sub>51</sub> H <sub>45</sub> N <sub>3</sub> O <sub>3</sub> S <sub>3</sub>
Formula weight	531.77	844.13
Temperature	120 K	293 K
Wavelength	1.5418 Å	1.5418 Å
Crystal system	Orthorhombic	Monoclinic
Space group	<i>Pcab</i>	<i>P2<sub>1</sub>/c</i>
	<i>a</i> = 8.672(7) Å	<i>a</i> = 12.0728(3) Å
	<i>b</i> = 14.767(8) Å	<i>b</i> = 25.2027(6) Å
	<i>c</i> = 42.471(11) Å	<i>c</i> = 14.0944(3) Å
	$\alpha$ = 90°	$\alpha$ = 90°
	$\beta$ = 90°	$\beta$ = 99.100(1)°
	$\gamma$ = 90°	$\gamma$ = 90°
	<i>V</i> = 5439(5) Å <sup>3</sup>	<i>V</i> = 4234.49(17) Å <sup>3</sup>
	<i>Z</i> = 8	<i>Z</i> = 4
Density (Calcd)	1.299 g/cm <sup>-3</sup>	1.324 g/cm <sup>-3</sup>
	2.669 mm <sup>-1</sup>	1.980 mm <sup>-1</sup>
Crystal size	0.15 × 0.10 × 0.10 mm	0.12 × 0.10 × 0.10 mm
Range for data collection ( $\theta$ )	2.08–62.33°	23.51–61.17°
Range of indices measured	<i>h</i> = 0–9	<i>h</i> = –13 to 13
	<i>k</i> = 0–14	<i>k</i> = –28 to 28
	<i>l</i> = 0–43	<i>l</i> = –16 to 15
Reflections collected	3028	10,544
Independent reflections	3028	6049
Refinement method	Full-matrix least-squares on <i>F</i> <sup>2</sup>	
Data/restraints/parameters	3028/54/380	6049/0/542
Goodness-of-fit on <i>F</i> <sup>2</sup>	1.002	1.068
Final <i>R</i> indices [ <i>I</i> > 2 $\sigma$ ( <i>I</i> )]	<i>R</i> <sub>1</sub> = 0.0565, <i>wR</i> <sub>2</sub> = 0.1456	<i>R</i> <sub>1</sub> = 0.0548, <i>wR</i> <sub>2</sub> = 0.1428
<i>R</i> indices (all data)	<i>R</i> <sub>1</sub> = 0.1035, <i>wR</i> <sub>2</sub> = 0.1731	<i>R</i> <sub>1</sub> = 0.0726, <i>wR</i> <sub>2</sub> = 0.1548
Largest diff. peak and hole	0.379 and –0.343 e Å <sup>-3</sup>	0.379 and –0.371 e Å <sup>-3</sup>
Deposition number	CCDC 249955	CCDC 258848

thermal parameters for these atoms. The disorder could be resolved completely and each of these seven atoms were split into two atomic positions with total site occupancy of one. An anisotropic refinement for all the non-hydrogen atoms, using 'rigid bond restraints' and 'same *U*<sub>ij</sub> restraints' for the disordered atoms, finally converged with an improved R factor. The H-bonding calculations, torsion and dihedral angles and plane were calculated by using PARST.<sup>29</sup> The CCDC numbers for **2** and **3a** are 249955 and 258848, respectively.

### Acknowledgements

Geeta Hundal thanks the CSIR (New Delhi, India) for research grant vide grant number 01(1796)/02/EMR-II and Narinder Singh is thankful to the CSIR for research fellowship.

### Supplementary data

Supporting information available: H-bonding tables for **2** and **3a**; mass spectra of **4**; unit cell diagram of **2**. Supplementary data associated with this article can be found, in the online version, at doi:10.1016/j.tet.2005.05.052

### References and notes

- Gokel, G. W.; Murillo, O. In Atwood, J. L., Davies, J. D., MacNicol, D. D., Vögtle, F., Eds.; Comprehensive Supramolecular Chemistry; Pergamon: Oxford, 1996; Vol. 1, p 1.
- Vögtle, F.; Müller, W. M.; Wehner, W.; Buhleier, E. *Angew. Chem., Int. Ed. Engl.* **1977**, *16*, 548–549.
- Heimann, U.; Herzhoff, M.; Vögtle, F. *Chem. Ber.* **1979**, *112*, 1392–1399.
- (a) Hong, M.; Zhao, Y.; Su, W.; Cao, R.; Fujita, M.; Zhou, Z.; Chan, A. S. C. *Angew. Chem. Int. Ed.* **2000**, *39*, 2468–2470. (b) Hartshorn, C. M.; Steel, P. J. *Chem. Commun.* **1997**, 541–542. (c) Sun, W. Y.; Fan, J.; Okamura, T.-a.; Xie, J.; Yu, K. B.; Ueyama, N. *Chem. Eur. J.* **2001**, *7*, 2557–2562. (d) Sui, B.; Fan, J.; Okamura, T.-a.; Sun, W.-Y.; Ueyama, N. *New J. Chem.* **2001**, *25*, 1379–1381. (e) Liu, H. K.; Sun, W.-Y.; Ma, D. J.; Yu, K. B.; Tang, W.-X. *Chem. Commun.* **2001**, 591–592. (f) Liu, H. K.; Sun, W.-Y.; Tang, W.-X.; Yamamoto, T.; Ueyama, N. *Inorg. Chem.* **1999**, *38*, 6313–6316. (g) Liu, H. K.; Sun, W.-Y.; Zhu, H. L.; Yu, K. B.; Tang, W.-X. *Inorg. Chim. Acta* **1999**, *295*, 129–135.
- Fan, J.; Sui, B.; Okamura, T.-a.; Sun, W.-Y.; Tang, W.-X.; Ueyama, N. *J. Chem. Soc., Dalton Trans.* **2002**, 3868–3873.
- (a) Nguyen, B. T.; Wiskur, S. L.; Ansyln, E. V. *Org. Lett.* **2004**, *6*, 2499–2501. (b) Piatek, A. M.; Bomble, Y. J.; Wiskur, S. L.; Ansyln, E. V. *J. Am. Chem. Soc.* **2004**, *126*, 6072–6077. (c) Manimala, J. C.; Wiskur, S. L.; Ellington, A. D.; Ansyln, E. V. *J. Am. Chem. Soc.* **2004**, *126*, 16516–16519. (d) McCleskey, S. C.; Griffin, M. J.; Schneider, S. E.; McDevitt, J. T.; Ansyln, E. V. *J. Am. Chem. Soc.* **2003**, *125*, 1114–1115. (e) Zhong, Z.; Ansyln, E. V. *J. Am. Chem. Soc.* **2002**, *124*, 9014–9015. (f) Wiskur, S. L.; Ansyln, E. V. *J. Am. Chem. Soc.* **2001**, *123*, 10109–10110. (g) Niikura, K.; Ansyln, E. V. *J. Org. Chem.* **2003**, *68*, 10156–10157. (h) Wiskur, S. L.; Lavigne, J. L.; Ait-Haddou, H.; Lynch, V.; Chiu, Y. H.; Canary, J. W.; Ansyln, E. V. *Org. Lett.* **2001**, *3*, 1311–1314. (i) Cabell, L. A.; Best, M. D.; Lavigne, J. J.; Schneider, S. E.;

- Perreault, D. M.; Monahan, M.-K.; Anslyn, E. V. *J. Chem. Soc., Perkin Trans. 2* **2001**, 315–323.
7. Hartshorn, C. M.; Steel, P. J. *Angew. Chem., Int. Ed. Engl.* **1996**, *22*, 2655–2657.
8. Graham, B.; Spiccia, L.; Fallon, G. D.; Hearn, M. T. W.; Mabbs, F. E.; Moubaraki, B.; Murray, K. S. *J. Chem. Soc., Dalton Trans.* **2001**, 1226–1232.
9. Mascal, M.; Kerdelhue, J.-L.; Blake, A. J.; Cooke, P. A. *Angew. Chem., Int. Ed.* **1999**, *38*, 1968–1971.
10. a) Curtis, N. F. *J. Chem. Soc.* **1960**, 4409–4413. (b) Curtis, N. F.; Curtis, Y. M.; Powell, H. J. K. *J. Chem. Soc. (A)* **1966**, 1015–1018. (c) Fenton, D. E.; Moody, R. *J. Chem. Soc., Dalton Trans.* **1987**, 219–220. (d) Bombieri, G.; Benetollo, F.; Polo, A.; Fonda, K. K.; Vallarino, L. M. *Polyhedron* **1991**, *12*, 1385–1394. (e) Cook, D. H.; Fenton, D. E.; Drew, M. G. B.; Mcfall, S. G.; Nelson, S. M. *J. Chem. Soc., Dalton Trans.* **1977**, 446–449. (f) Drew, M. G. B.; Yates, P. C.; Trocha-Grimshaw, J.; McKillop, K. P.; Nelson, S. M. *J. Chem. Soc., Chem. Commun.* **1985**, 262–263. (g) Adams, H.; Bailey, N. A.; Fenton, D. E.; Moss, S.; Rodriguez de Barbarin, C. O.; Jones, G. J. *J. Chem. Soc., Dalton Trans.* **1986**, 693–699. (h) Menif, R.; Martell, A. E. *J. Chem. Soc., Chem. Commun.* **1989**, 1521–1523. (i) Liu, Y.; Zhao, B.-T.; Zhang, H.-Y.; Wada, T.; Inoue, Y. *J. Chem. Soc., Perkin Trans. 2* **2001**, 1219–1223. (j) Pal, S.; Pal, S. *J. Chem. Soc., Dalton Trans.* **2002**, 2102–2108. For reviews of this extensive area of chemistry see: (k) Curtis, N. F. *Coord. Chem. Rev.* **1968**, *3*, 3–47. (l) Lindoy, L. F.; Busch, D. H. In Jolly, W. L., Ed.; *Preparative Inorganic Reactions*; Interscience: New York, 1971; Vol. 6, p 1.
11. Panja, S.; Chowdhury, S.; Drew, M. G. B.; Datta, D. *Inorg. Chem. Commun.* **2002**, *5*, 304–307 and references therein.
12. Steed, J. W.; Atwood, J. L. *Supramolecular Chemistry*; Wiley: New York, 2000.
13. (a) Barefield, E. K.; Wagner, F.; Herlinger, A. W.; Dahl, A. R. *Inorg. Synth.* **1976**, *16*, 220–225. (b) Dietrich-Buchecker, C. O.; Sauvage, J.-P. *Chem. Rev.* **1987**, *87*, 795–810. (c) Barefield, E. K.; Sauvage, J.-P.; Kern, J.-M. *J. Am. Chem. Soc.* **1984**, *106*, 3043–3045. (d) Chamberon, J.-C.; Heitz, V.; Sauvage, J.-P. *J. Am. Chem. Soc.* **1993**, *115*, 12378–12384. (e) Ashton, P. R.; Johnston, M. R.; Stoddart, J. F.; Tolley, M. S.; Wheeler, J. W. *J. Chem. Soc., Chem. Commun.* **1992**, 1128–1131. (f) Wu, C.; Lecavalier, P. R.; Shen, Y. X.; Gibson, H. W. *Chem. Mater.* **1991**, *3*, 569–572.
14. Attempts were made to obtain a solid complex  $2 \cdot \text{Zn}(\text{ClO}_4)_2$  by reacting the two in a 1:1 ratio in acetonitrile– $\text{CHCl}_3$  mixture and refluxing. The  $^1\text{H}$  NMR of the separated solid taken in  $\text{CDCl}_3$  again showed an upfield shift of 0.90 ppm in the chemical shift value of the amine protons. However, this complex was not stable over longer periods as the crystallization of this solid from acetonitrile always yielded the crystals of the amine **2** only with neither zinc nor perchlorate ions being present in it. Also the mass spectrum of the solid and its CHN analysis (which are recorded externally and takes some time) showed the compound to be amine **2** only. This shows that the complex  $2 \cdot \text{Zn}(\text{ClO}_4)_2$  is not very stable. In fact the amine protons show a down field shift  $\Delta\delta$  0.71 ppm if the  $^1\text{H}$  NMR of **2** alone is taken in deuterated DMSO, with other signals showing no significant shift. This shift can only be due to H-bonding of the amine protons with DMSO. These comparable shifts of amine protons in the zinc complex and in polar solvent DMSO, though in opposite directions, hint towards the former being only as stable as a H-bonded complex of the amine **2**.
15. Singh, N.; Kumar, M.; Hundal, G. *Inorg. Chim. Acta* **2004**, *14*, 4286–4290.
16. Luneau, D.; Evans, C. J. *J. Chem. Soc., Dalton Trans.* **2002**, 83–86.
17. Svehla, G. *Vogel's Qualitative Inorganic Analysis*, 6th ed.; Orient Longman: UK, 1979; p 130.
18. Lu, Q.; Luo, Q. H.; Dai, A. B.; Zhou, Z. Y.; Hu, G. Z. *J. Chem. Soc., Chem. Commun.* **1990**, 1429–1430.
19. Dutta, B.; Bag, P.; Adhikary, B.; Flörke, U.; Nag, K. *J. Org. Chem.* **2004**, *69*, 5419–5427.
20. (a) Golding, B. T.; Harrowfield, J. MacB.; Sargeson, A. M. *J. Am. Chem. Soc.* **1974**, *96*, 3003–3004. (b) Bell, J. D.; Gainsford, A. R.; Golding, B. T.; Herlt, A. J.; Sargeson, A. M. *J. Chem. Soc., Chem. Commun.* **1974**, 980–981. (c) Gainsford, A. R.; Sargeson, A. M. *Aust. J. Chem.* **1978**, *31*, 1679–1688. (d) Gainsford, A. R.; Pizer, R. D.; Sargeson, A. M.; Whimp, P. O. *J. Am. Chem. Soc.* **1981**, *103*, 792–805. (e) Engelhardt, L. M.; Gainsford, A. R.; Gainsford, G. J.; Golding, B. T.; Harrowfield, J. MacB.; Herlt, A. J.; Sargeson, A. M.; White, A. H. *Inorg. Chem.* **1988**, *27*, 4551–4563.
21. Browne, J. M. W.; Wikaira, J.; Fitchet, C. M.; Hartshorn, R. M. *J. Chem. Soc., Dalton Trans.* **2002**, 2227–2234.
22. Balamurugan, V.; Hundal, M. S.; Mukherjee, R. *Chem. Eur. J.* **2004**, *10*, 1683–1690.
23. Drew, M. G. B.; Tocher, D. A.; Chowdhury, K.; Chowdhury, S.; Datta, D. *New J. Chem.* **2004**, *28*, 323–325.
24. Frausto da Silva, J. J. R.; Williams, R. J. P. *The Biological Chemistry of the Elements—the Inorganic Chemistry of Life*; Oxford University Press: Oxford, 1991.
25. Harrowfield, J. MacB.; Sargeson, A. M. *J. Am. Chem. Soc.* **1974**, *96*, 2634–2635.
26. Kopylovich, M. N.; Kukushkin, V. Y.; Haukka, M.; Frausto da Silva, J. J. R.; Pombeiro, A. J. L. *Inorg. Chem.* **2002**, *41*, 4798–4804.
27. Barbosa, L. A. M. M.; van Santen, R. A. *J. Mol. Catal. A: Chem.* **2001**, *166*, 101–121.
28. Sheldrick, G. M. *SHELXTL-PC*. Release 5.03, Siemens Analytical X-ray Instruments Inc., WI, USA, 1995.
29. Nardelli, M. *PARST, Comput. Chem.* **1983**, 95–98.

# Indium (III) mediated Markovnikov addition of malonates and $\beta$ -ketoesters to terminal alkynes and the formation of Knoevenagel condensation products

Ji Zhang,\* Peter G. Blazecka, Paul Angell, Mark Lovdahl and Timothy T. Curran

Chemical Research and Development, Pfizer Global Research & Development, Michigan Laboratories, Pfizer, Inc., 2800 Plymouth Road, Ann Arbor, MI 48105, USA

Received 28 March 2005; revised 17 May 2005; accepted 18 May 2005

Available online 22 June 2005

**Abstract**—The indium(III) triflate mediated addition of active methylene compounds to terminal alkynes has been expanded to use malonates and low boiling terminal alkynes to form the Markovnikov addition products. Indium(III) chloride and indium(III) bromide were also found to be efficient catalysts. Knoevenagel condensation products were isolated when reactions involved a simple malonate or  $\beta$ -ketoester.

© 2005 Elsevier Ltd. All rights reserved.

## 1. Introduction

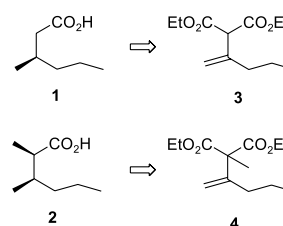
Developing environmentally friendly, or green and atom efficient processes is becoming more and more important in modern organic chemistry.<sup>1</sup> Indium(III) salts, such as indium(III) triflate and indium(III) chloride, are efficient green Lewis acids<sup>2</sup> and have become the focus of attention in several organic reactions.<sup>3</sup> A particularly powerful application of this Lewis acid in the preparation of terminal olefins was recently reported by Nakamura and co-workers.<sup>4</sup> The indium triflate (0.5–5%) promoted addition of  $\beta$ -ketoester and 1,3-diketone to terminal alkynes described therein attracted our attention. Compounds **1** and **2** (Fig. 1) are important intermediates in Pfizer's drug research and development program, and we envisioned that these molecules could be accessed through intermediates **3** and **4**, products of an indium(III) promoted addition employing malonates as the active methylene species.

Moreover, terminal olefins comprise one of the most important classes of compounds vis a vis functional group transformation, giving alcohols, amines, aldehydes carboxylic acid derivatives, ethers and epoxides as products of various catalytic reactions.<sup>5</sup> The recent revolution in olefin metathesis and ring-closing metathesis (RCM) led by Grubbs,<sup>6</sup> Schrock,<sup>7</sup> Hoveyda<sup>8</sup> and others<sup>9</sup> also raises the

question of our ability to prepare densely functionalized olefins using metal catalysis. Although the classic Wittig olefination<sup>10</sup> or Horner–Emmons reaction<sup>11</sup> has been used frequently to prepare terminal olefins, the Wittig reaction suffers from the generation of a notorious side-product, phosphine oxide. Indeed developing a green, simple and efficient method to prepare functionalized, terminal olefins, reducing our dependence on the Wittig reaction is extremely significant.

## 2. Results and discussion

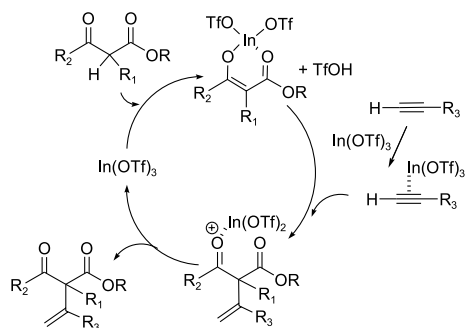
There were several issues to address at the beginning of our study. First, could malonate be one of the starting materials? Secondly, could low boiling alkynes, such as 1-pentyne (bp 39–41 °C) and 1-hexyne (bp 71–72 °C) be employed under neat conditions involving temperatures of 100–140 °C? Finally, although it was reported that other Lewis acids are not efficient and only indium triflate works well,<sup>4</sup> would



**Figure 1.** Some useful compounds potentially from the reaction of malonate and 1-alkynes mediated by indium(III).

**Keywords:** Indium (III); Active methylene; Alkyne; Markovnikov; Knoevenagel.

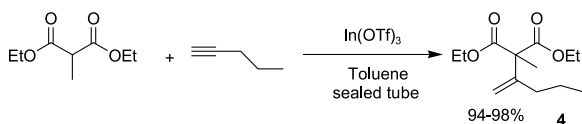
\* Corresponding author. Tel.: +1 734 622 3940; fax: +1 734 622 3294; e-mail: ji.zhang@pfizer.com



**Figure 2.** Possible mechanism of In(III) mediated addition of  $\beta$ -ketoester to terminal alkyne.

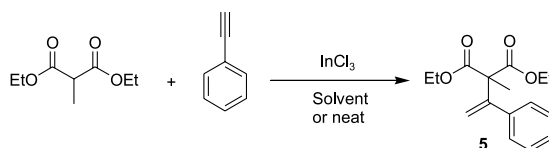
other indium salts be effective? Furthermore, by what mechanism does the reaction proceed? In light of some related reports using allylindiums in the allylation of unactivated alkynes<sup>12</sup> and an indium(III) catalyst in the Friedel–Crafts alkenylation of arenes using alkynes,<sup>13</sup> as well as indium triflate as an alkyne activator to catalyze a double addition of heterocyclic arenes to alkyne,<sup>13</sup> we believe the mechanistic rationale proposed by Nakamura<sup>4</sup> might be incomplete. Since other Lewis acids that favored the formation of the enolate anion<sup>14</sup> did not promote this reaction, we therefore postulate that activation of alkyne is required in order for the reaction to proceed (Fig. 2).<sup>15</sup>

The low boiling point of 1-pentyne and the desired reaction temperature of 100–140 °C necessitated performing the reaction in a sealed tube. Employing Nakamura's conditions, a neat mixture of nearly stoichiometric amounts of 1-pentyne and diethyl methylmalonate and 5% In(OTf)<sub>3</sub> was heated to 100–140 °C for 10 h (Scheme 1). Surprisingly, it gave only a low yield of desired product, as well as at least two other significant side-products. We also



**Scheme 1.** Addition of malonate to low boiling alkyne.

**Table 1.** Solvent screen using InCl<sub>3</sub><sup>a</sup>



Entry	Solvent	Temperature (°C)	Additive <sup>b</sup>	Conversion (%) <sup>c</sup>	
				4 h	20 h
1	<i>o</i> -Xylene	135	—	35	94
2	<i>o</i> -Xylene	135	NMM	0	1
3	Toluene	110	—	2	53
4	Toluene	110	NMM	0	0
5	Dioxane	100	—	0	0
6	Neat	140	—	61	98
7	Neat	140	NMM	7	34

<sup>a</sup> Reaction conditions: 1 equiv (2.0 mmol) of diethyl methylmalonate, 1.2 equiv of phenylacetylene, 0.02 equiv of InCl<sub>3</sub>, neat or with desired solvent, 20 h at desired temperature.

<sup>b</sup> 0.10 equiv *N*-methylmorpholine (NMM).

<sup>c</sup> Amount of product relative to malonate. Determined by HPLC analysis of reaction mixture after desired reaction time.

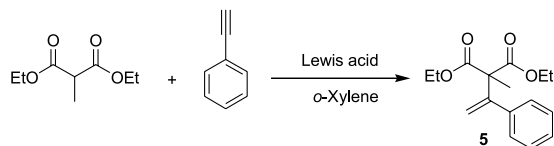
observed that as the heating continued, the reaction became self-heating causing the temperature to rise quickly in a very short time. This is a potential safety concern for large scale application.

Thus, we decided to dilute the neat mixture with a high boiling, non-polar solvent, such as toluene. The reaction proceeded very well under these conditions. On 20 mmol scale the desired product was isolated in 98% yield. A 1.2 mole scale reaction afforded product in 98% yield, isolated by simple vacuum distillation. This reaction proceeded without the previously described exotherm.

A solvent screen (Table 1) revealed *o*-xylene (bp 143–145 °C) to be an ideal solvent in which to run the reaction at higher temperature with excellent yield when phenylacetylene was the reactant. Indeed, neat conditions also provided the desired product in excellent yield on this scale. Addition of an amine base such as *N*-methylmorpholine, reported to promote formation of the enolate,<sup>16</sup> had a deleterious effect.

A screen of various Lewis acids was then conducted using the reaction between phenylacetylene and diethyl methylmalonate as the model. The study (Table 2) revealed that other indium(III) salts could promote the reaction as efficiently as In(OTf)<sub>3</sub>. However, the unique nature of indium was once again illustrated by the lack of reactivity exhibited by other Lewis acids.

We then turned our attention to other alkynes (Table 3). Unlike phenylacetylene, 3-phenyl-1-propyne and 4-phenyl-1-butyne gave products **8** and **9** in 58 and 54% yield. If activation of the alkyne by In(OTf)<sub>3</sub> occurs, it will form the carbocation intermediate suggested by Shirakawa.<sup>13</sup> The phenyl group is much better at stabilizing the cation than an alkyl group. Since this is a highly regioselective reaction, giving the Markovnikov addition product (branched product) even under the high temperature/sealed tube conditions, it strongly suggests that electronic effects are much more important than steric effects in governing the regiochemistry. Otherwise one might expect the reaction

**Table 2.** Lewis acid screen<sup>a</sup>

Entry	Catalyst	Yield (%) <sup>b</sup>
1	La(OTf) <sub>3</sub>	Trace
2	Mg(OTf) <sub>2</sub>	ND <sup>c</sup>
3	Sc(OTf) <sub>3</sub>	Trace
4	Sn(OTf) <sub>2</sub>	8
5	Zn(OTf) <sub>2</sub>	ND
6	Yb(OTf) <sub>3</sub>	ND
7	InCl <sub>3</sub>	88
8	InBr <sub>3</sub>	92
9	In(OAc) <sub>3</sub>	ND
10	InF <sub>3</sub>	ND

<sup>a</sup> Reaction conditions: 1 equiv (10 mmol) of diethyl methylmalonate, 1.2 equiv of phenylacetylene, 0.05 equiv of desired Lewis acid, *o*-xylene, 16 h at 125–130 °C. The reaction time was not optimized.

<sup>b</sup> Isolated yield after purification by silica gel chromatography. Products estimated to be >95% pure by <sup>1</sup>H NMR and elemental analysis.

<sup>c</sup> ND = not detected.

would provide the anti-Markovnikov addition product (linear product).

The classic Knoevenagel reaction is the condensation of an aldehyde or ketone with an activated methylene compound in the presence of ammonia or amine.<sup>17</sup> Recently, it was reported that the reaction is catalyzed by Lewis acid.<sup>18</sup> The Knoevenagel acceptors are versatile intermediates for Michael addition,<sup>19</sup> Diels–Alder reaction<sup>20</sup> and Pinner reaction.<sup>21</sup> When an unsubstituted malonate was used in this indium(III) mediated reaction, a mixture of conjugated and unconjugated products was formed (Table 4). In some cases, only the Knoevenagel condensation products or alkylidenemalonates were observed. When a  $\beta$ -ketoester was used, it also afforded a mixture of conjugated and unconjugated products, which was inconsistent with Nakamura's study.<sup>4</sup> It is generally accepted that the Knoevenagel condensation between ketones and malonate is often unachievable by using conventional methodology.<sup>22</sup> Thus, this indium (III) mediated highly regioselective Markovnikov addition of malonates and other activated methylene compounds to terminal alkynes, giving high yield of Knoevenagel condensation products, provides an alternative approach.

### 3. Conclusion

In summary, the indium triflate mediated addition of activated methylene compounds to terminal alkynes has been expanded to use malonates and low boiling terminal alkynes to form Markovnikov addition products. Other indium(III) salts, such as indium chloride and indium bromide were also found to be efficient catalysts. When an unsubstituted malonate or  $\beta$ -ketoester was used, Knoevenagel condensation product was formed. Further investigations, including extension of the use of this reaction will be reported in due course.

## 4. Experimental

### 4.1. General

All reactions were carried out under nitrogen atmosphere unless otherwise noted. All solvents and reagents used were from commercial sources and no further purification was performed. Reactions were monitored by mass spectrometry (MS) on a Micromass Platform LC and by thin-layer chromatography on 0.25 mm E. Merck silica gel 60 plates (F254) using UV light and aqueous potassium permanganate–sodium bicarbonate as visualizing agents. E. Merck silica gel 60 (0.040–0.063 mm and 0.063–0.200 mm particle sizes) was used for column chromatography. Proton nuclear magnetic resonance (<sup>1</sup>H NMR) spectra were recorded at 400 MHz on a Varian UNITY INOVA AS400. Chemical shifts are reported as delta ( $\delta$ ) units in parts per million (ppm) relative to the singlet at 7.26 ppm for deuteriochloroform. Coupling constants (*J*) are reported in Hertz (Hz). Carbon-13 nuclear magnetic resonance (<sup>13</sup>C NMR) spectra were recorded at 100 MHz on a Varian UNITY Plus INOVA 400. Chemical shifts are reported as delta ( $\delta$ ) units in parts per million (ppm) relative to the center line of the triplet at 77.3 ppm for deuteriochloroform. Elemental analyses were performed out-of-house by Quantitative Technologies Inc.

### 4.2. General procedure for indium(III) mediated Markovnikov addition of diethyl methylmalonate to phenylacetylene (Table 1). Compound 5

Diethyl methylmalonate (0.348 g, 2.00 mmol) was combined with phenylacetylene (0.245 g, 2.40 mmol, 1.20 equiv) and InCl<sub>3</sub> (9 mg, 0.04 mmol, 0.02 equiv), with or without *N*-methylmorpholine (20 mg, 0.20 mmol, 0.10 equiv), in the desired solvent (10 mL), or in the absence of solvent, and heated at a few degrees below reflux for 20 h. Relative amounts of product and malonate starting material in the reaction mixtures were determined by HPLC analysis.

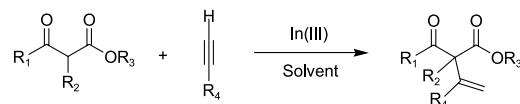
### 4.3. General procedure for metal mediated Markovnikov addition of diethyl methylmalonate to phenylacetylene (Table 2). Compound 5

Diethyl methylmalonate (1.74 g, 10.0 mmol) was combined with phenylacetylene (1.23 g, 12.0 mmol, 1.20 equiv) and the desired Lewis acid catalyst (0.50 mmol, 0.05 equiv) in *o*-xylene (10 mL) and stirred at 125–130 °C for 16 h. The reaction mixture was concentrated under reduced pressure, and the residue was purified by silica gel column chromatography (ethyl acetate/heptane).

### 4.4. General procedure for indium(III) mediated Markovnikov addition of malonates and $\beta$ -ketoesters to terminal alkynes (reagents with bp < 130 °C). Compounds 4, 6, 17 and 19

The desired malonate or  $\beta$ -ketoester (10.0 mmol) was combined with the desired alkyne (12.0 mmol, 1.2 equiv) and the desired indium (III) catalyst (0.05–0.20 mmol, 0.005–0.02 equiv) in toluene or *o*-xylene (10 mL) and heated at 140 °C in a sealed tube for 10–20 h. The reaction



**Table 3.** Addition of different 1-alkynes to branched malonates and  $\beta$ -ketoesters<sup>a</sup>

Entry	Product	Catalyst/Rxn temperature (°C)	Yield (%) <sup>b</sup>
1		In(OTf) <sub>3</sub> /110	95
2		In(OTf) <sub>3</sub> /110 <sup>c</sup>	98
3		InCl <sub>3</sub> /130	58
4		In(OTf) <sub>3</sub> /110 InCl <sub>3</sub> /130 InBr <sub>3</sub> /130	84 88 92
5		InCl <sub>3</sub> /130 InBr <sub>3</sub> /130	58 30
6		InCl <sub>3</sub> /130 InBr <sub>3</sub> /130	54 35
7		InCl <sub>3</sub> /140	81
8		InCl <sub>3</sub> /130	82
9		InCl <sub>3</sub> /130	50
10		InCl <sub>3</sub> /130	41
11		InCl <sub>3</sub> /130	96
12		InCl <sub>3</sub> /130	43

<sup>a</sup> Reaction conditions: 1 equiv (10–20 mmol) of malonate or  $\beta$ -ketoester, 1.2–1.5 equiv of desired alkyne, 0.005–0.05 equiv of desired indium(III) salt, *o*-xylene or toluene, 10–24 h at 110–140 °C. The reaction time was not optimized.

<sup>b</sup> Isolated yield after purification by silica gel chromatography. Products estimated to be >95% pure by <sup>1</sup>H NMR and elemental analysis.

<sup>c</sup> Reaction repeated on 0.6 and 1.2 mol scales with identical results.

mixture was concentrated under reduced pressure, and the residue was purified by silica gel column chromatography (ethyl acetate/heptane).

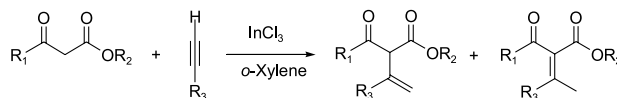
**4.4.1. 2-Methyl-2-(1-methylenebutyl)malonic acid diethyl ester (4).** <sup>1</sup>H NMR (CDCl<sub>3</sub>):  $\delta$  0.90 (t,  $J$ =7.3 Hz, 3H), 1.23 (t,  $J$ =7.1 Hz, 6H), 1.44–1.53 (m, 2H), 1.56 (s, 3H), 2.01–2.05 (m, 2H), 4.17 (q,  $J$ =7.2 Hz, 4H), 4.96–4.98 (m, 1H), 5.02–5.04 (m, 1H). <sup>13</sup>C NMR (CDCl<sub>3</sub>):  $\delta$  14.2, 21.0, 21.9, 35.1, 60.8, 61.6, 112.2, 147.0, 171.5. Anal. Calcd for C<sub>13</sub>H<sub>22</sub>O<sub>4</sub>: C, 64.44; H, 9.15. Found: C, 64.54; H, 8.82.

**4.4.2. 2-Methyl-2-(1-methylenepropyl)malonic acid diethyl ester (6).** <sup>1</sup>H NMR (CDCl<sub>3</sub>):  $\delta$  1.08 (t,  $J$ =7.5 Hz, 3H), 1.25 (t,  $J$ =7.1 Hz, 6H), 1.59 (s, 3H), 2.12 (q,  $J$ =7.2 Hz, 2H), 4.19 (q,  $J$ =7.1 Hz, 4H), 4.98–5.01 (m, 1H),

5.05–5.07 (m, 1H). <sup>13</sup>C NMR (CDCl<sub>3</sub>):  $\delta$  12.9, 14.2, 21.0, 25.7, 60.8, 61.6, 111.6, 148.6, 171.5. Anal. Calcd for C<sub>12</sub>H<sub>20</sub>O<sub>4</sub>: C, 63.14; H, 8.83. Found: C, 63.12; H, 8.36.

**4.4.3. 2-(1-Methylbutylidene)malonic acid diethyl ester (17).** <sup>1</sup>H NMR (CDCl<sub>3</sub>):  $\delta$  0.92 (t,  $J$ =7.4 Hz, 3H), 1.26 (t,  $J$ =7.1 Hz, 3H), 1.27 (t,  $J$ =7.1 Hz, 3H), 1.52 (m, 2H), 2.04 (s, 3H), 2.30 (m, 2H), 4.20 (q,  $J$ =7.1 Hz, 2H), 4.21 (q,  $J$ =7.1 Hz, 2H). <sup>13</sup>C NMR (CDCl<sub>3</sub>):  $\delta$  14.2, 20.8, 21.4, 38.8, 60.9, 61.0, 124.8, 166.0, 158.8, 165.7. Anal. Calcd for C<sub>10</sub>H<sub>20</sub>O<sub>4</sub>: C, 63.14; H, 8.83. Found: C, 63.14; H, 8.75.

**4.4.4. 2-(1-Methylpentylidene)malonic acid diethyl ester (19).** <sup>1</sup>H NMR (CDCl<sub>3</sub>):  $\delta$  0.90 (t,  $J$ =7.3 Hz, 3H), 1.27 (t,  $J$ =7.1 Hz, 3H), 1.27 (t,  $J$ =7.1 Hz, 3H), 1.33 (m, 2H), 1.47 (m, 2H), 2.05 (s, 3H), 2.33 (m, 2H), 4.21 (q,  $J$ =7.1 Hz, 2H),

**Table 4.** Addition of 1-alkynes to simple malonates or  $\beta$ -ketoesters<sup>a</sup>

Entry	S.m.	Alkyne	Products (%yield) <sup>b</sup>	
1			<b>16</b> (0%)	<b>17</b> (75%)
2			<b>18</b> (0%)	<b>19</b> (82%)
3 <sup>c</sup>			<b>20</b> (8%)	<b>21</b> (71%)
4 <sup>d</sup>			<b>20</b> (9%)	<b>21</b> (82%)
5			<b>22</b> (22%)	<b>23</b> <sup>e</sup> (60%)
6			<b>24</b> (22%)	<b>25</b> <sup>e</sup> (53%)

<sup>a</sup> Reaction conditions: 1 equiv (10 mmol) of malonate or  $\beta$ -ketoester, 1.2–1.5 equiv of desired alkyne, 0.01–0.05 equiv of  $\text{InCl}_3$ , *o*-xylene, 16–20 h at 130–140 °C. The reaction time was not optimized.

<sup>b</sup> Isolated yield after purification by silica gel chromatography. Products estimated to be >95% pure by  $^1\text{H}$  NMR and elemental analysis.

<sup>c</sup> Used 1.2 equiv of alkyne. Compounds **20** and **21** isolated as 1:9 mixture.

<sup>d</sup> Used 1.5 equiv of alkyne. Compounds **20** and **21** isolated as 1:9 mixture.

<sup>e</sup> Compounds **23** and **25** isolated as mixtures of *E* and *Z* isomers.

4.22 (q,  $J=7.1$  Hz, 2H).  $^{13}\text{C}$  NMR ( $\text{CDCl}_3$ ):  $\delta$  14.0, 14.2, 20.9, 22.9, 30.2, 36.7, 60.9, 61.0, 124.6, 159.1, 165.7, 166.0. Anal. Calcd for  $\text{C}_{13}\text{H}_{22}\text{O}_4$ : C, 64.44; H, 9.15. Found: C, 64.70; H, 8.94.

#### 4.5. General procedure for indium(III) mediated Markovnikov addition of malonates and $\beta$ -ketoesters to terminal alkynes (reagents with bp > 130 °C). Compounds 5, 7–15 and 20–25

The desired malonate or  $\beta$ -ketoester (10.0 mmol) was combined with the desired alkyne (12.0–15.0 mmol, 1.20–1.50 equiv) and the desired indium (III) catalyst (0.10–0.50 mmol, 0.01–0.05 equiv) in toluene or *o*-xylene (10 mL), and heated at 110–140 °C for 16–24 h. The reaction mixture was concentrated under reduced pressure, and the residue was purified by silica gel column chromatography (ethyl acetate/heptane).

**4.5.1. 2-Methyl-2-(1-phenylvinyl)malonic acid diethyl ester (5).**  $^1\text{H}$  NMR ( $\text{CDCl}_3$ ):  $\delta$  1.20 (t,  $J=7.1$  Hz, 6H), 1.59 (s, 3H), 4.14–4.21 (m, 4H), 5.34 (d,  $J=0.7$  Hz, 2H), 7.23–7.28 (m, 5H).  $^{13}\text{C}$  NMR ( $\text{CDCl}_3$ ):  $\delta$  14.1, 22.5, 60.3, 61.9, 118.3, 127.6, 128.1, 128.5, 141.0, 148.0, 171.6. Anal. Calcd for  $\text{C}_{16}\text{H}_{20}\text{O}_4$ : C, 69.55; H, 7.30. Found: C, 69.68; H, 7.29.

**4.5.2. 2-Methyl-2-(1-methylenenonyl)malonic acid diethyl ester (7).**  $^1\text{H}$  NMR ( $\text{CDCl}_3$ ):  $\delta$  0.87 (t,  $J=7.1$  Hz, 3H), 1.21–1.33 (m, 16H), 1.41–1.52 (m, 2H), 1.59 (s, 3H),

2.03–2.10 (m, 2H), 4.19 (q,  $J=7.16$  Hz, 4H), 4.98–5.00 (m, 1H), 5.05–5.07 (m, 1H).  $^{13}\text{C}$  NMR ( $\text{CDCl}_3$ ):  $\delta$  14.2, 14.3, 21.0, 22.9, 28.8, 29.5, 29.8, 32.1, 33.0, 60.8, 61.6, 112.1, 147.3, 171.5. Anal. Calcd for  $\text{C}_{18}\text{H}_{32}\text{O}_4$ : C, 69.19; H, 10.32. Found: C, 69.21; H, 10.39.

**4.5.3. 2-(1-Benzylvinyl)-2-methylmalonic acid diethyl ester (8).**  $^1\text{H}$  NMR ( $\text{CDCl}_3$ ):  $\delta$  1.27 (t,  $J=7.1$  Hz, 6H), 1.66 (s, 3H), 3.47 (s, 2H), 4.19 (q,  $J=7.1$  Hz, 4H), 4.72–4.79 (m, 1H), 5.10–5.16 (m, 1H), 7.15–7.31 (m, 5H).  $^{13}\text{C}$  NMR ( $\text{CDCl}_3$ ):  $\delta$  14.2, 21.2, 39.7, 60.4, 61.8, 115.9, 126.4, 128.5, 129.8, 139.5, 146.8, 171.4. Anal. Calcd for  $\text{C}_{17}\text{H}_{22}\text{O}_4$ : C, 70.32; H, 7.64. Found: C, 70.59; H, 7.79.

**4.5.4. 2-Methyl-2-(1-methylene-3-phenylpropyl)malonic acid diethyl ester (9).**  $^1\text{H}$  NMR ( $\text{CDCl}_3$ ):  $\delta$  1.27 (t,  $J=7.1$  Hz, 6H), 1.62 (s, 3H), 2.38–2.46 (m, 2H), 2.78–2.86 (m, 2H), 4.21 (q,  $J=7.2$  Hz, 4H), 5.09 (br s, 1H), 5.18 (br s, 1H), 7.14–7.30 (m, 5H).  $^{13}\text{C}$  NMR ( $\text{CDCl}_3$ ):  $\delta$  14.2, 21.1, 34.9, 35.2, 60.8, 61.7, 112.9, 126.1, 128.6, 128.6, 142.1, 146.6, 171.4. Anal. Calcd for  $\text{C}_{18}\text{H}_{24}\text{O}_4$ : C, 71.03; H, 7.95. Found: C, 71.34; H, 8.18.

**4.5.5. 2-Methoxy-2-(1-phenylvinyl)malonic acid dimethyl ester (10).**  $^1\text{H}$  NMR ( $\text{CDCl}_3$ ):  $\delta$  3.49 (s, 3H), 3.73 (s, 6H), 5.52 (s, 1H), 5.76 (s, 1H), 7.28 (m, 3H), 7.42 (m, 2H).  $^{13}\text{C}$  NMR ( $\text{CDCl}_3$ ):  $\delta$  53.1, 54.3, 87.8, 121.6, 127.2, 128.1, 128.4, 138.7, 142.4, 168.2. Anal. Calcd for  $\text{C}_{14}\text{H}_{16}\text{O}_5$ : C, 63.63; H, 6.10. Found: C, 64.01; H, 6.12.

**4.5.6. 2-Acetyl-2-methyl-3-phenylbut-3-enoic acid ethyl ester (11).**  $^1\text{H}$  NMR ( $\text{CDCl}_3$ ):  $\delta$  1.19 (t,  $J=7.1$  Hz, 3H), 1.51 (s, 3H), 2.28 (s, 3H), 4.16 (dq,  $J=7.1$  Hz, 0.6, 2H), 5.27 (br s, 1H), 5.42 (br s, 1H), 7.16–7.31 (m, 5H).  $^{13}\text{C}$  NMR ( $\text{CDCl}_3$ ):  $\delta$  14.1, 21.5, 27.6, 61.8, 66.0, 119.0, 127.8, 128.0, 128.3, 140.6, 148.2, 172.0, 205.5. Anal. Calcd for  $\text{C}_{15}\text{H}_{18}\text{O}_3$ : C, 73.15; H, 7.37. Found: C, 73.20; H, 7.03.

**4.5.7. 2-Acetyl-3-benzyl-2-methylbut-3-enoic acid ethyl ester (12).**  $^1\text{H}$  NMR ( $\text{CDCl}_3$ ):  $\delta$  1.26 (t,  $J=7.2$  Hz, 3H), 1.56 (s, 3H), 2.24 (s, 3H), 3.37 (s, 2H), 4.17 (q,  $J=7.2$  Hz, 2H), 4.80–4.89 (m, 1H), 5.06–5.14 (m, 1H), 7.16–7.31 (m, 5H).  $^{13}\text{C}$  NMR ( $\text{CDCl}_3$ ):  $\delta$  14.2, 20.2, 27.3, 39.7, 61.7, 66.2, 116.7, 126.6, 128.6, 129.8, 139.0, 147.0, 171.9, 205.4. Anal. Calcd for  $\text{C}_{16}\text{H}_{20}\text{O}_3$ : C, 73.82; H, 7.74. Found: C, 74.02; H, 7.63.

**4.5.8. 2-Acetyl-2-methyl-3-methylene-5-phenylpentanoic acid ethyl ester (13).**  $^1\text{H}$  NMR ( $\text{CDCl}_3$ ):  $\delta$  1.27 (t,  $J=7.2$  Hz, 3H), 1.53 (s, 3H), 2.20 (s, 3H), 2.29–2.36 (m, 2H), 2.77–2.84 (m, 2H), 4.21 (q,  $J=7.2$  Hz, 2H), 5.01–5.11 (m, 1H), 5.22–5.28 (m, 1H), 7.13–7.31 (m, 5H).  $^{13}\text{C}$  NMR ( $\text{CDCl}_3$ ):  $\delta$  14.3, 19.9, 27.3, 34.9, 35.0, 61.7, 66.6, 113.9, 126.2, 128.5, 128.6, 141.8, 146.8, 172.0, 205.5. Anal. Calcd for  $\text{C}_{17}\text{H}_{22}\text{O}_3$ : C, 74.42; H, 8.08. Found: C, 74.76; H, 7.84.

**4.5.9. 2-(1-Biphenyl-4-ylvinyl)-2-methylmalonic acid diethyl ester (14).**  $^1\text{H}$  NMR ( $\text{CDCl}_3$ ):  $\delta$  1.23 (t,  $J=7.1$  Hz, 6H), 1.65 (s, 1H), 4.17–4.25 (m, 4H), 5.40 (d,  $J=15.6$  Hz, 2H), 7.35 (m, 1H) 7.32–7.60 (m, 9H).  $^{13}\text{C}$  NMR ( $\text{CDCl}_3$ ):  $\delta$  14.1, 22.6, 60.3, 61.9, 118.3, 126.8, 127.2, 127.6, 128.9, 129.0, 140.0, 140.4, 140.9, 147.7, 171.6. Anal. Calcd for  $\text{C}_{22}\text{H}_{24}\text{O}_4$ : C, 74.98; H, 6.86. Found: C, 74.63; H, 6.78.

**4.5.10. 2-[1-(4-Methoxyphenyl)-vinyl]-2-methylmalonic acid diethyl ester (15).**  $^1\text{H}$  NMR ( $\text{CDCl}_3$ ):  $\delta$  1.21 (t,  $J=7.1$  Hz, 6H), 1.58 (s, 3H), 3.78 (s, 3H), 4.14–4.22 (m, 4H), 5.28 (d,  $J=10.0$  Hz, 2H), 6.77–6.83 (m, 2H) 7.16–7.22 (m, 2H).  $^{13}\text{C}$  NMR ( $\text{CDCl}_3$ ):  $\delta$  14.1, 22.5, 55.4, 60.4, 61.8, 113.4, 117.6, 129.6, 133.3, 147.5, 159.1, 171.7. Anal. Calcd for  $\text{C}_{17}\text{H}_{22}\text{O}_5$ : C, 66.65; H, 7.24. Found: C, 67.06; H, 7.22.

**4.5.11. 2-(1-Phenylvinyl)malonic acid diethyl ester (20).**  $^1\text{H}$  NMR ( $\text{CDCl}_3$ ):  $\delta$  1.23 (t,  $J=7.1$  Hz, 6H), 4.20 (dq,  $J=7.1$ , 1.7 Hz, 4H), 4.60 (d,  $J=1.0$  Hz, 1H), 4.51 (d,  $J=0.7$  Hz, 1H), 5.63 (s, 1H), the phenyl protons of **20** not distinguishable from those of **21**.  $^{13}\text{C}$  NMR ( $\text{CDCl}_3$ ):  $\delta$  14.2, 57.4, 62.0, 117.9, 126.4, 126.4, 140.4, 140.9. Anal. Calcd for  $\text{C}_{15}\text{H}_{18}\text{O}_4$ : C, 68.69; H, 6.92. Found: C, 68.95; H, 6.85. Data from analysis of 1:9 mixture of **20:21**.

**4.5.12. 2-(1-Phenylethylidene)malonic acid diethyl ester (21).**  $^1\text{H}$  NMR ( $\text{CDCl}_3$ ):  $\delta$  0.95 (t,  $J=7.1$  Hz, 3H), 1.31 (t,  $J=7.1$  Hz, 3H), 2.43 (s, 3H), 3.95 (q,  $J=7.1$  Hz, 2H), 4.28 (q,  $J=7.1$  Hz, 2H), 7.28 (m, 5H).  $^{13}\text{C}$  NMR ( $\text{CDCl}_3$ ):  $\delta$  13.8, 14.3, 23.0, 61.1, 61.3, 126.8, 128.5, 128.6, 141.8, 155.9, 165.0, 166.4, 168.1. Anal. Calcd for  $\text{C}_{15}\text{H}_{18}\text{O}_4$ : C, 68.69; H, 6.92. Found: C, 68.95; H, 6.85. Data from analysis of 1:9 mixture of **20:21**.

**4.5.13. 3-Hydroxy-2-(1-phenylvinyl)but-2-enoic acid ethyl ester (22).**  $^1\text{H}$  NMR ( $\text{CDCl}_3$ ):  $\delta$  1.01 (t,  $J=7.1$  Hz, 3H), 2.03 (d,  $J=1.0$  Hz, 3H), 4.07 (q,  $J=7.1$  Hz, 2H), 5.16

(d,  $J=1.7$  Hz, 1H), 5.75 (d,  $J=1.5$  Hz, 1H), 7.22–7.41 (m, 5H), 12.99–13.06 (m, 1H).  $^{13}\text{C}$  NMR ( $\text{CDCl}_3$ ):  $\delta$  14.1, 19.8, 60.6, 103.9, 117.8, 126.1, 127.7, 128.5, 141.0, 142.7, 172.7, 174.3. Anal. Calcd for  $\text{C}_{14}\text{H}_{16}\text{O}_3$ : C, 72.39; H, 6.94. Found: C, 72.63; H, 6.77.

**4.5.14. 2-Acetyl-3-phenylbut-2-enoic acid ethyl ester (23).**  $^1\text{H}$  NMR ( $\text{CDCl}_3$ ):  $\delta$  0.91 (dt,  $J=7.1$ , 1.5 Hz, 1.3H), 1.30 (dt,  $J=7.1$ , 1.3 Hz, 1.7H), 1.85 (d,  $J=1.5$  Hz, 1.7H), 2.32 (d,  $J=1.2$  Hz, 1.3H), 2.34 (d,  $J=1.2$  Hz, 1.3H), 2.39 (d,  $J=1.2$  Hz, 1.7H), 3.93 (dq,  $J=7.1$ , 1.3 Hz, 0.8H), 4.26 (dq,  $J=7.1$ , 1.3 Hz, 1.2H), 7.16–7.39 (m, 5H).  $^{13}\text{C}$  NMR ( $\text{CDCl}_3$ ):  $\delta$  13.7, 14.3, 23.1, 23.3, 30.6, 31.2, 61.2, 61.3, 126.8, 127.5, 128.5, 128.9, 129.1, 133.7, 134.4, 141.1, 142.3, 152.4, 154.3, 165.7, 167.4, 198.4, 201.9. Anal. Calcd for  $\text{C}_{14}\text{H}_{16}\text{O}_3$ : C, 72.39; H, 6.94. Found: C, 72.57; H, 6.93.

**4.5.15. 3-Hydroxy-2-(1-phenylvinyl)hex-2-enoic acid ethyl ester (24).**  $^1\text{H}$  NMR ( $\text{CDCl}_3$ ):  $\delta$  0.89 (t,  $J=7.5$  Hz, 3H), 1.01 (t,  $J=7.2$  Hz, 3H), 1.57–1.68 (m, 2H), 2.25–2.33 (m, 2H), 4.07 (q,  $J=7.1$  Hz, 2H), 5.15 (d,  $J=1.5$  Hz, 1H), 5.75 (d,  $J=1.7$  Hz, 1H), 7.21–7.42 (m, 5H) 13.05–13.09 (s, 1H).  $^{13}\text{C}$  NMR ( $\text{CDCl}_3$ ):  $\delta$  14.1, 14.2, 20.5, 34.9, 60.6, 103.6, 117.6, 126.2, 127.7, 128.4, 141.1, 142.5, 172.9, 177.3. Anal. Calcd for  $\text{C}_{16}\text{H}_{20}\text{O}_3$ : C, 73.82; H, 7.74. Found: C, 73.90; H, 7.69.

**4.5.16. 3-Oxo-2-(1-phenylethylidene)hexanoic acid ethyl ester (25).**  $^1\text{H}$  NMR ( $\text{CDCl}_3$ ):  $\delta$  0.63 (t,  $J=7.5$  Hz, 1.7H), 0.88–0.99 (m, 2.6H), 1.28 (t,  $J=7.1$  Hz, 1.7H), 1.34 (q,  $J=7.1$  Hz, 1.2H), 1.69 (q,  $J=7.1$  Hz, 0.8H), 2.06 (t,  $J=7.2$  Hz, 1.2H), 2.26 (s, 1.2H), 2.41 (s, 1.8H), 2.60 (t,  $J=7.2$  Hz, 0.8H), 3.93 (q,  $J=7.2$  Hz, 0.8H), 4.24 (q,  $J=7.1$  Hz, 1.2H), 7.15–7.37 (m, 5H).  $^{13}\text{C}$  NMR ( $\text{CDCl}_3$ ):  $\delta$  13.6, 13.8, 13.9, 14.3, 17.2, 17.4, 22.9, 23.3, 44.7, 45.7, 61.1, 126.8, 127.7, 128.4, 128.4, 128.7, 128.9, 133.8, 134.2, 141.2, 142.3, 152.0, 153.4, 165.6, 167.0, 201.5, 204.7. Anal. Calcd for  $\text{C}_{16}\text{H}_{20}\text{O}_3$ : C, 73.82; H, 7.74. Found: C, 73.84; H, 7.83.

## References and notes

- For recent examples, see: (a) Uozumi, Y.; Nakai, Y. *Org. Lett.* **2002**, *4*, 2997. (b) Choi, E.; Lee, C.; Na, Y.; Chang, S. *Org. Lett.* **2002**, *4*, 2369. (c) Skyler, D.; Heathcock, C. H. *Org. Lett.* **2001**, *3*, 4323.
- (a) Fu, N.-Y.; Pang, M.-L.; Yuan, Y.-F.; Wang, J.-T. *Youji Huaxue* **2003**, *23*, 1085. (b) Kobayashi, S.; Manabe, K. *Acc. Chem. Res.* **2002**, *35*, 209. (c) Kobayashi, S.; Manabe, K. *Pure Appl. Chem.* **2000**, *72*, 1373.
- Zhang, J.; Li, C.-J. *J. Org. Chem.* **2002**, *67*, 3969. See also: Nguyen, R.-V.; Yao, X.-Q.; Bohle, D. S.; Li, C.-J. *Org. Lett.* **2005**, *7*, 673.
- Nakamura, M.; Endo, K.; Nakamura, E. *J. Am. Chem. Soc.* **2003**, *125*, 13002. See also: Nakamura, M.; Fujimoto, T.; Endo, K.; Nakamura, E. *Org. Lett.* **2004**, *6*, 4837.
- Borman, S. *Chem. Eng. News* **2004**, *82*, 42.
- (a) Chatterjee, A. K.; Sanders, D. P.; Grubbs, R. H. *Org. Lett.* **2002**, *4*, 1939. (b) Trnka, T. M.; Grubbs, R. H. *Acc. Chem. Res.* **2001**, *34*, 18. (c) Chatterjee, A. K.; Grubbs, R. H. *Org. Lett.*

- 1999, 1, 1751. (d) Grubbs, R. H.; Chang, S. *Tetrahedron* **1998**, 54, 4413. (e) Fu, G. C.; Grubbs, R. H. *J. Am. Chem. Soc.* **1992**, 114, 7234.
7. (a) Schrock, R. R.; Hoveyda, A. H. *Angew. Chem., Int. Ed.* **2003**, 42, 4592. (b) Schrock, R. R. *Tetrahedron* **1999**, 55, 8141.
8. (a) Dolman, S. J.; Schrock, R. R.; Hoveyda, A. H. *Org. Lett.* **2003**, 5, 4899. (b) Teng, X.; Cefalo, D. R.; Schrock, R. R.; Hoveyda, A. H. *J. Am. Chem. Soc.* **2002**, 124, 10779. (c) Dolman, S. J.; Sattely, E. S.; Hoveyda, A. H.; Schrock, R. R. *J. Am. Chem. Soc.* **2002**, 124, 6991. (d) Van Veldhuizen, J. J.; Garber, S. B.; Kingsbury, J. S.; Hoveyda, A. H. *J. Am. Chem. Soc.* **2002**, 124, 4954. (e) Hoveyda, A. H.; Schrock, R. R. *Chem. Eur. J.* **2001**, 7, 945.
9. (a) For an account of olefin metathesis, see: Rouhi, A. M. *Chem. Eng. News* **2002**, 80, 29. (b) Rouhi, A. M. *Chem. Eng. News* **2002**, 80, 34. (c) For recent examples of olefin metathesis, see: Ratnayake, A. S.; Hemscheidt, T. *Org. Lett.* **2002**, 4, 4667. (d) Deiters, A.; Martin, S. F. *Org. Lett.* **2002**, 4, 3243. (e) Takao, K.-i.; Watanabe, G.; Yasui, H.; Tadano, K.-i. *Org. Lett.* **2002**, 4, 2941. (f) Creighton, C. J.; Reitz, A. B. *Org. Lett.* **2001**, 3, 893. (g) Smulik, J. A.; Diver, S. T. *Org. Lett.* **2000**, 2, 2271.
10. (a) Wittig, G.; Haag, W. *Ber.* **1955**, 88, 1654. (b) Wittig, G.; Schöllkopf, U. *Ber.* **1954**, 87, 1318. (c) For reviews, see: Kelly, S. E. *Comp. Org. Synth.* **1991**, 1, 755. (d) Maryanoff, B. E.; Reitz, A. B. *Chem. Rev.* **1989**, 89, 863. (e) Gosney, I.; Rowley, A. G. In *Organophosphorus Reagents in Organic Synthesis*; Cadogan, J. I. G., Ed.; Academic: New York, 1979; pp 17–153. (f) Wadsworth, W. S., Jr. *Org. React.* **1977**, 25, 73. (g) Vollhardt, K. P. C. *Synthesis* **1975**, 765. (h) Maercker, A. *Org. React.* **1965**, 14, 270.
11. Wadsworth, W. S., Jr.; Emmons, W. D. *J. Am. Chem. Soc.* **1961**, 83, 1733.
12. (a) Fujiwara, N.; Yamamoto, Y. *J. Org. Chem.* **1999**, 64, 4095. (b) Ranu, B. C.; Majee, A. *Chem. Commun.* **1997**, 1225. (c) Fujiwara, N.; Yamamoto, Y. *J. Org. Chem.* **1997**, 62, 2318.
13. (a) Tsuchimoto, T.; Hatanaka, K.; Shirakawa, E.; Kawakami, Y. *Chem. Commun.* **2003**, 2454. (b) Tsuchimoto, T.; Maeda, T.; Shirakawa, E.; Kawakami, Y. *Chem. Commun.* **2000**, 1573.
14. Barnes, D. M.; Ji, J.; Fickes, M. G.; Fitzgerald, M. A.; King, S. A.; Morton, H. E.; Plagge, F. A.; Preskill, M.; Wagaw, S. H.; Wittenberger, S. J.; Zhang, J. *J. Am. Chem. Soc.* **2002**, 124, 13097.
15. Takita, R.; Fukuta, Y.; Tsuji, R.; Ohshima, T.; Shibasaki, M. *Org. Lett.* **2005**, 7, 1363.
16. (a) Yang, D.; Li, J.-H.; Gao, Q.; Yan, Y.-L. *Org. Lett.* **2003**, 5, 2869. (b) Yang, D.; Gao, Q.; Lee, C.-S.; Cheung, K.-K. *Org. Lett.* **2002**, 4, 3271.
17. Jones, G. *Org. React.* **1967**, 15, 204.
18. For Lewis acid catalyzed Knoevenagel reactions, see: (a) Narsaiah, A. V.; Nagaiah, K. *Synth. Commun.* **2003**, 33, 3825. (b) Harjani, J. R.; Nara, S. J.; Salunkhe, M. M. *Tetrahedron Lett.* **2002**, 43, 1127. (c) Rao, P. S.; Venkataratnam, R. V. *Tetrahedron Lett.* **1991**, 32, 5821.
19. (a) Sabitha, G.; Reddy, G. S. K. K.; Rajkumar, M.; Yadav, J. S.; Ramakrishna, K. V. S.; Kunwar, A. C. *Tetrahedron Lett.* **2003**, 44, 7455. (b) Kaupp, G.; Naimi-Jamal, M. R.; Schmeyers, J. *Tetrahedron* **2003**, 59, 3753. (c) Tedeschi, L.; Enders, D. *Org. Lett.* **2001**, 3, 3515.
20. (a) Ramachary, D. B.; Chowdari, N. S.; Barbas, C. F., III *Synlett* **2003**, 1910. (b) Ramachary, D. B.; Chowdari, N. S.; Barbas, C. F., III *Angew. Chem., Int. Ed.* **2003**, 42, 4233. (c) Tietze, L. F.; Evers, H.; Topken, E. *Helv. Chim. Acta* **2002**, 85, 4200. (d) Tietze, L. F.; Zhou, Y. *Angew. Chem., Int. Ed.* **1999**, 38, 2045. (e) Tietze, L. F.; Bachmann, J.; Schul, W. *Angew. Chem., Int. Ed. Engl.* **1988**, 100, 983.
21. (a) Fringuelli, F.; Piermatti, O.; Pizzo, F. *Synlett* **2003**, 2331. (b) Bigi, F.; Chesini, L.; Maggi, R.; Sartori, G. *J. Org. Chem.* **1999**, 64, 1033.
22. (a) Davis, A.; Bhattarai, K. M. *Tetrahedron* **1995**, 51, 8033. (b) Brillon, D.; Sauvé, G. *J. Org. Chem.* **1992**, 57, 1838. (c) Hein, R. W.; Astle, M. J.; Shelton, J. R. *J. Org. Chem.* **1961**, 26, 4874. (d) Cope, A. C. *J. Am. Chem. Soc.* **1937**, 59, 2327.

# Regiochemical control of the ring opening of 1,2-epoxides by means of chelating processes. Part 18: Regioselectivity of the opening reactions with MeOH of 1-(benzyloxy)-2,3- and -3,4-epoxyalkanes under condensed and gas phase operating conditions

Paolo Crotti,<sup>a,\*</sup> Gabriele Renzi,<sup>b,\*</sup> Graziella Roselli,<sup>b</sup> Valeria Di Bussolo,<sup>a</sup> Laura Lucarelli<sup>b</sup> and Maria Rosaria Romano<sup>a</sup>

<sup>a</sup>Dipartimento di Chimica Bioorganica e Biofarmacia, Università di Pisa, Via Bonanno 33, 56126 Pisa, Italy

<sup>b</sup>Dipartimento di Scienze Chimiche, Università di Camerino, Via S. Agostino 1, 62032 Camerino, Italy

Received 11 February 2005; revised 3 May 2005; accepted 12 May 2005

Available online 22 June 2005

Dedicated to the memory of Professor Ivano Morelli

**Abstract**—The regiochemical behavior of a series of aliphatic open chain epoxides bearing a heterofunctionality in an allylic or homoallylic relationship has been examined in the opening reaction with MeOH under both condensed and gas phase operating conditions. The results indicate that the proton (actually D<sup>+</sup>) possesses in the gas phase intrinsic chelating properties which are even superior than those of Li<sup>+</sup> in the condensed phase.

© 2005 Elsevier Ltd. All rights reserved.

## 1. Introduction

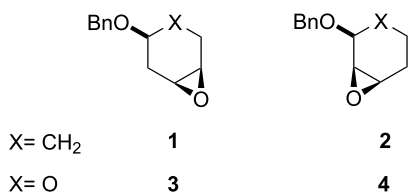
Nucleophilic ring opening reactions of aliphatic and cycloaliphatic 1,2-epoxides with the associated commonly observed complete *anti*-stereoselectivity offer a valid tool for the construction of two adjacent stereogenic centers.<sup>1</sup> The drawback of this procedure is, in some cases, the absence of regioselectivity, leading to undesired mixtures of regioisomers, which need to be separated. In this sense, the presence of a heterofunctionality, such as a simple ether group, in an allylic or homoallylic relationship to the oxirane ring, turns out to be capable of directing regioselectively the nucleophilic attack on one or the other oxirane carbon depending on the reaction conditions (standard or chelating).<sup>2–4</sup> This effect has been observed and studied particularly in ring opening reactions with different nucleophiles (MeOH, NaN<sub>3</sub>, Et<sub>2</sub>NH, PhSH) of suitable OBn-substituted *cis*-oxirane systems derived from

cyclohexene oxide (epoxides **1–4**),<sup>3</sup> where the use of chelating conditions by means of a Lewis acid such as LiClO<sub>4</sub> in a polar aprotic (MeCN, in the reactions with NaN<sub>3</sub>, Et<sub>2</sub>NH and PhSH) or protic solvent (MeOH, used as the solvent-nucleophile in the methanolysis reactions)<sup>4</sup> modifies the conformational equilibrium of the starting epoxide and determines a regiochemical behavior opposite to that observed under standard conditions with the same nucleophile (H<sub>2</sub>SO<sub>4</sub>/MeOH, NH<sub>4</sub>Cl/NaN<sub>3</sub>, Et<sub>2</sub>NH/EtOH, PhSH/NEt<sub>3</sub>).<sup>3,4</sup> In this framework, *cis*-epoxide **1** (taken as an example) reacts in the methanolysis reaction under standard conditions (H<sub>2</sub>SO<sub>4</sub>/MeOH) in its more stable conformation **1a**, which, in accordance with the Fürst-Plattner rule, allows nucleophilic attack on the C(2) of the protonated intermediate **5** to give mostly a *C-2 product* (the *trans* hydroxy ether, HE, **6**).<sup>5</sup> On the contrary, under chelating conditions, the incursion of the chelated bidentate species **7** through the metal (M=Li<sup>+</sup>) forces the epoxide to react in its less stable conformation **1b**, in which the nucleophilic attack necessarily occurs at the C(1)-oxirane carbon, to give mostly the corresponding regioisomeric *C-1 product*, the *trans* HE **8** (Scheme 1).<sup>3a,5</sup>

**Keywords:** Epoxides; Regioselectivity; Gas phase reactions; Chelation.

\* Corresponding authors. Tel.: +39 050 2219 690, fax: +39 050 2219 660 (P.C.); tel./fax: +39 0737 402219 (G.R.);

e-mail addresses: [crotti@farm.unipi.it](mailto:crotti@farm.unipi.it); [gabriele.renzi@unicam.it](mailto:gabriele.renzi@unicam.it)

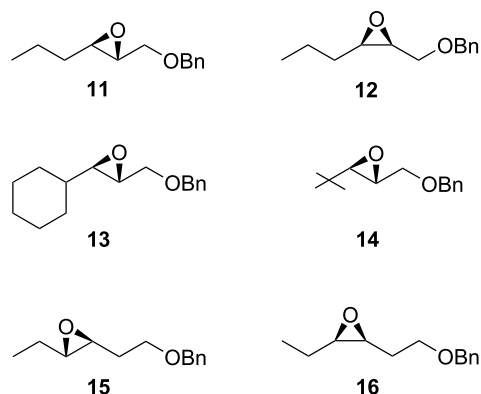


Appropriate considerations and comparison of the results obtained in the acid methanolysis both in the condensed and in the gas phase (vide infra) clearly indicated that, in the reactions carried out in the condensed phase ( $\text{H}_2\text{SO}_4/\text{MeOH}$ ), the proton did not show any chelating ability. As a consequence, the results obtained under these conditions were taken as a useful reference point indicating the basic, intrinsic regioselectivity of each epoxide studied.

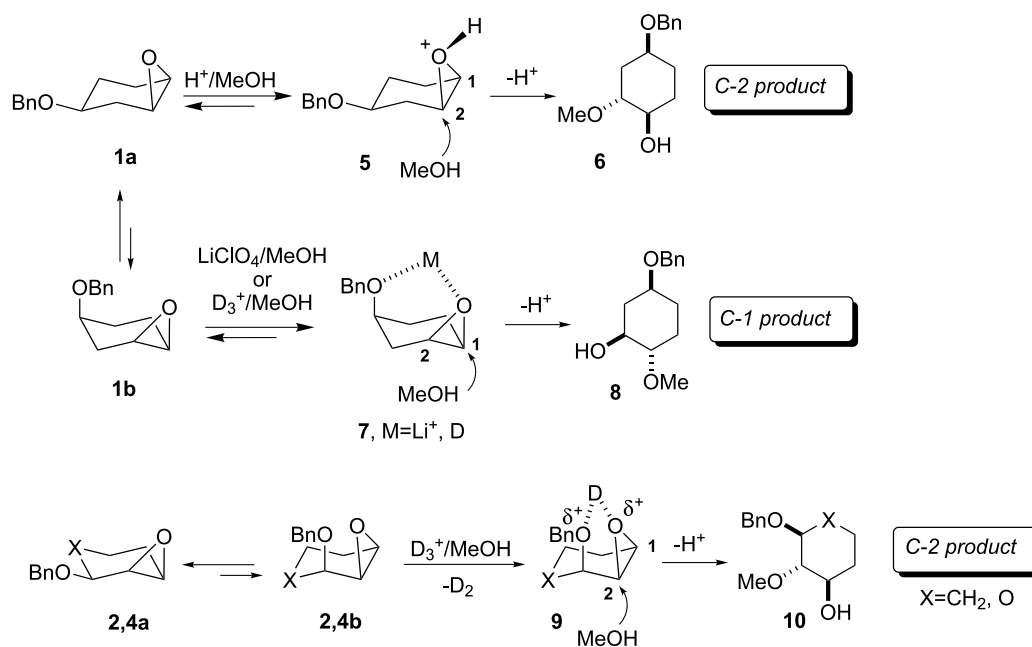
Different is the situation found in the reactions of epoxides **1–4** with MeOH under gas phase operating conditions ( $\text{D}_3^+$  in  $\text{D}_2$ , in the presence of a small amount of MeOH), where the gaseous Brønsted acid  $\text{D}^+$  (from  $\text{D}_3^+$ ), an analog of  $\text{H}^+$  in the condensed phase, turned out to be a very effective chelating agent, in some cases even superior to  $\text{Li}^+$ , whose chelating properties are well-known,<sup>3,6</sup> capable of modifying the regiochemical result obtained under standard conditions in the condensed phase. As an example, in the formerly examined epoxide **1**, the use of gaseous opening conditions with MeOH led to a significant increase in the amount of HE **8** (*C-1 product*, 37%) with respect to findings in the condensed phase under standard conditions (15%),<sup>7a</sup> whereas in the case of epoxides **2** and **4**, the corresponding HE **10** (*C-2 product*), completely absent in the methanolysis reaction carried out in the condensed phase under both standard and chelating conditions, could be obtained only under the gas phase protocol (46 and 53% from epoxide **2** and **4**, respectively),<sup>7</sup> in a neat regioalternating process. These results were reasonably attributed to the incursion of

the corresponding chelated bidentate species **7** (from **1**,  $\text{M} = \text{D}$ ) and **9** (from **2** and **4**), mediated by  $\text{D}^+$  (Scheme 1).<sup>7</sup>

Indeed, in the *O*-functionalized cyclic oxirane systems of epoxides **1–4**, the chelating processes, both by  $\text{Li}^+$  in the condensed phase and by  $\text{D}^+$  in the gas phase, could have been facilitated by the semirigid nature and the related reduced conformational freedom of the cyclohexane ring, which practically allows the presence, as shown for epoxides **1**, **2** and **4** taken as valid examples, of only the corresponding two conformers **a** and **b**: in the more stable conformer **a**, chelation is not possible, whereas in the less stable conformer **b**, it is. The presence, in the opening processes of both conformers **a** and **b**, of well-defined stereoelectronic effects, corresponding to the Fürst–Plattner rule of *trans* diaxial opening, determines the regioselectivity observed (Scheme 1).



In structurally related aliphatic *O*-functionalized epoxides derived from non-cyclic systems, the incursion of corresponding chelating processes mediated by  $\text{D}^+$  and the subsequent obtainment of a different regiochemical behavior in the gas phase could be hindered by entropic



Scheme 1.

factors, as a consequence of the increased conformational freedom associated with non-cyclic systems.

We have now examined the regiochemical behavior of aliphatic –OBn-substituted non-fused epoxides **11–16** in the acid methanolysis reaction, both in the condensed and in the gas phase, in order to evaluate whether  $D^+$  is able to chelate between the two *O*-functionalities (oxirane and OBn oxygens) and, consequently, to influence the regioselectivity also in these conformationally unrestricted systems.<sup>8</sup> In epoxides **11–14**, the heterofunctionality is in an allylic relationship with the oxirane ring, whereas in epoxides **15–16**, a homoallylic relationship is present between the two functionalities. Whereas in epoxides **11–12** and **15–16**, the respective secondary oxirane carbons further away from the –OBn group are sterically equivalent, a considerable difference in steric hindrance is present in epoxides **13** and **14**, in which the corresponding oxirane carbon actually corresponds to an isobutyl and a neopentyl position, respectively.

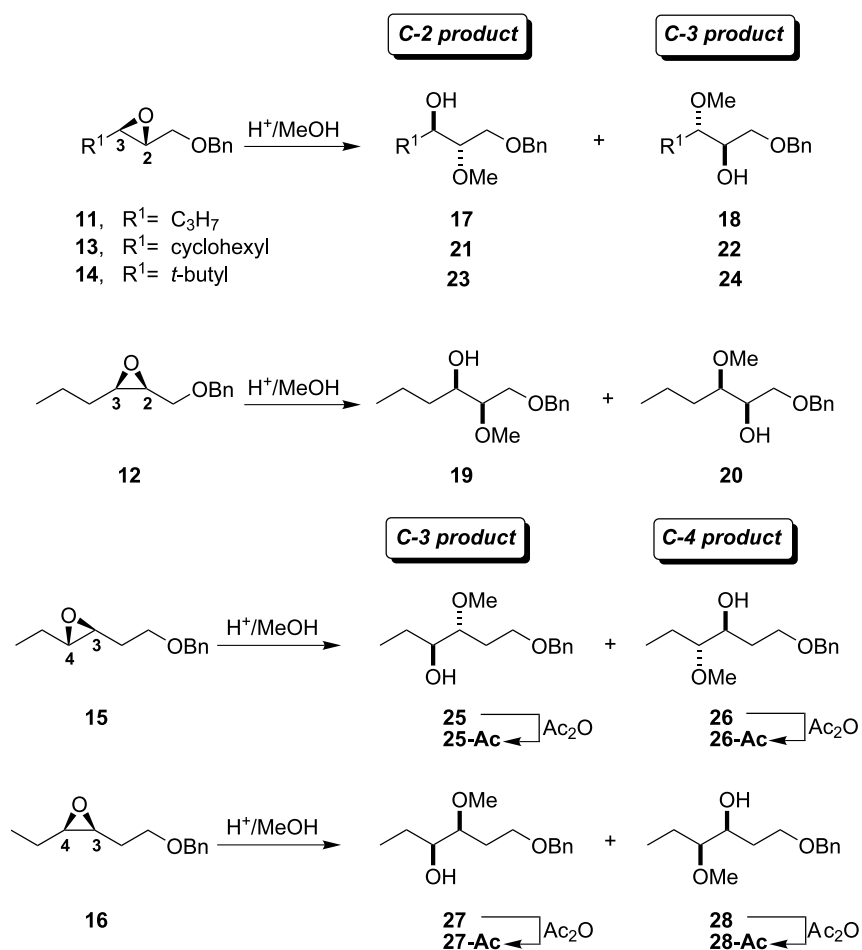
## 2. Results

Synthesis of epoxides **11–16** was carried out, as previously described, by oxidation (MCPBA) of the corresponding (*E*)-

or (*Z*)-*O*-benzyl substituted olefins prepared from commercially or easily available unsaturated alcohols.<sup>9,10</sup>

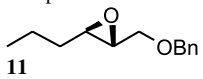
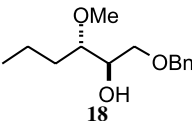
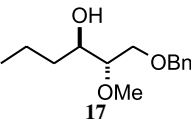
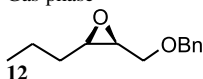
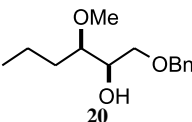
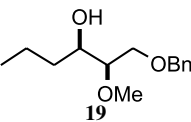
The reference compounds, the pairs of regioisomeric hydroxy ethers (HEs), *C*-2- and *C*-3-products from epoxides **11–14** and *C*-3- and *C*-4-products from epoxides **15–16**, were prepared as follows (Scheme 2).<sup>5</sup> The direct methanolysis ( $H_2SO_4/MeOH$ ) of epoxides *trans*-**11**, and *trans*-**13–16** afforded the corresponding mixtures of HEs **17** (*C*-2 product) and **18** (*C*-3 product) from *trans*-**11** (21:79 ratio), HEs **21** (*C*-2 product) and **22** (*C*-3 product) from *trans*-**13** (30:70 ratio), HEs **23** (*C*-2-product) and **24** (*C*-3 product) from *trans*-**14** (93:7 ratio), HEs **25** (*C*-3 product) and **26** (*C*-4 product) from *trans*-**15** (37:63 ratio), HEs **27** (*C*-3 product) and **28** (*C*-4 product) from *cis*-**16** (43:57 ratio) (Tables 1–3), which were separated by preparative TLC. In the case of the *cis*-epoxide **12**, the 20:80 mixture of the corresponding HEs **19** (*C*-2 product) and **20** (*C*-3 product) turned out to be unseparable by common chromatographic techniques (vide infra).

The exact structure, regio- and stereochemistry of HEs **17–28** has been clearly derived from the configuration of the starting epoxide, the completely *anti*-stereoselective ring-opening process commonly observed in typically aliphatic oxirane system like epoxides **11–16**, and by appropriate

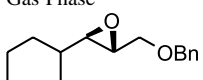
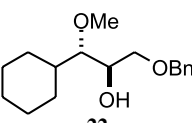
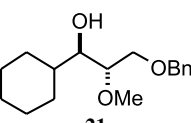
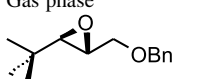
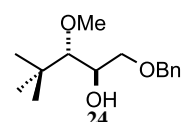
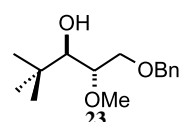


Scheme 2.

**Table 1.** Distribution of products in the gas phase acid-induced ring-opening with MeOH and in the methanolysis (condensed phase) of epoxides *trans* **11** and *cis* **12**

System composition (Torr) <sup>a</sup>				Product distribution <sup>b</sup>				Total abs. yield% <sup>c</sup>
				<i>C-3 product</i>		<i>C-2 product</i>		
Gas phase								
								
Epoxide	Bulk gas	NMe <sub>3</sub>	MeOH	<i>G</i>	%	<i>G</i>	%	
(0.55)	D <sub>2</sub> (760)	—	(1.68)	(1.82)	89	(0.22)	11	68
(0.58)	D <sub>2</sub> (760)	3	(1.81)	(0.63)	<b>98</b>	(0.03)	<b>2</b>	22
Condensed phase				<b>79</b>		<b>21</b>		
0.2 N H <sub>2</sub> SO <sub>4</sub> /MeOH				<b>87</b>		<b>13</b>		
10 M LiClO <sub>4</sub> /MeOH								
Gas phase								
								
Epoxide	Bulk gas	NMe <sub>3</sub>	MeOH	<i>G</i>	%	<i>G</i>	%	Total abs. yield% <sup>c</sup>
(0.61)	D <sub>2</sub> (760)	—	(1.79)	(1.64)	84	(0.22)	16	65
(0.57)	D <sub>2</sub> (760)	3	(1.72)	(0.53)	<b>90</b>	(0.03)	<b>10</b>	20
Condensed phase				<b>80</b>		<b>20</b>		
0.2 N H <sub>2</sub> SO <sub>4</sub> /MeOH				<b>84</b>		<b>16</b>		
10 M LiClO <sub>4</sub> /MeOH								

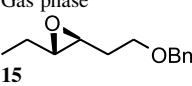
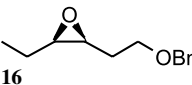
<sup>a</sup> O<sub>2</sub>: 4 Torr, radiation dose 1.5 × 10<sup>4</sup> Gy (dose rate 1 × 10<sup>4</sup> Gy h<sup>-1</sup>).<sup>b</sup> *G* values expressed as the number of molecules produced per 100 eV absorbed energy.<sup>c</sup> Total absolute yields (%) estimated from the percentage ratio of the combined *G*(M) values of products and the literature *G*(GA<sup>+</sup>) values.<sup>14</sup>**Table 2.** Distribution of products in the gas phase acid-induced ring-opening with MeOH and in the methanolysis (condensed phase) of epoxides *trans* **13** and *cis* **14**

System composition (Torr) <sup>a</sup>				Product distribution <sup>b</sup>				Total abs. yield% <sup>c</sup>
				<i>C-3 product</i>		<i>C-2 product</i>		
Gas Phase								
								
Epoxide	Bulk gas	NMe <sub>3</sub>	MeOH	<i>G</i>	%	<i>G</i>	%	Total abs. yield% <sup>c</sup>
(0.51)	D <sub>2</sub> (760)	—	(1.55)	(1.90)	81	(0.44)	19	78
(0.62)	D <sub>2</sub> (760)	3	(1.85)	(0.88)	<b>98</b>	(0.05)	<b>2</b>	31
Condensed phase				<b>70</b>		<b>30</b>		
0.2 N H <sub>2</sub> SO <sub>4</sub> /MeOH				<b>87</b>		<b>13</b>		
10 M LiClO <sub>4</sub> /MeOH								
Gas phase								
								
Epoxide	Bulk gas	NMe <sub>3</sub>	MeOH	<i>G</i>	%	<i>G</i>	%	Total abs. yield% <sup>c</sup>
(0.63)	D <sub>2</sub> (760)	—	(1.90)	(0.22)	17	(1.74)	83	70
(0.54)	D <sub>2</sub> (760)	3	(1.64)	(0.03)	<b>34</b>	(0.62)	<b>66</b>	29
Condensed phase				<b>7</b>		<b>93</b>		
0.2 N H <sub>2</sub> SO <sub>4</sub> /MeOH				<b>18</b>		<b>82</b>		
10 M LiClO <sub>4</sub> /MeOH								

<sup>a</sup> O<sub>2</sub>: 4 Torr, radiation dose 1.5 × 10<sup>4</sup> Gy (dose rate 1 × 10<sup>4</sup> Gy h<sup>-1</sup>).<sup>b</sup> *G* values expressed as the number of molecules produced per 100 eV absorbed energy.<sup>c</sup> Total absolute yields (%) estimated from the percentage ratio of the combined *G*(M) values of products and the literature *G*(GA<sup>+</sup>) values.<sup>14</sup>



**Table 3.** Distribution of products in the gas phase acid-induced ring-opening with MeOH and in the methanolysis (condensed phase) of epoxides *trans* **15** and *cis* **16**

System composition (Torr) <sup>a</sup>				Product distribution <sup>b</sup>				Total abs. yield% <sup>c</sup>
				<i>C-4 product</i>		<i>C-3 product</i>		
Gas phase  <b>15</b>								
Epoxide	Bulk gas	NMe <sub>3</sub>	MeOH	<i>G</i>	%	<i>G</i>	%	
(0.52)	D <sub>2</sub> (760)	—	(1.58)	(1.41)	66	(0.72)	34	71
(0.63)	D <sub>2</sub> (760)	3	(1.88)	(0.59)	<b>81</b>	(0.19)	<b>19</b>	26
Condensed phase					<b>63</b>		<b>37</b>	
0.2 N H <sub>2</sub> SO <sub>4</sub> /MeOH					<b>68</b>		<b>32</b>	
10 M LiClO <sub>4</sub> /MeOH								
Gas Phase  <b>16</b>								
Epoxide	Bulk gas	NMe <sub>3</sub>	MeOH	<i>G</i>	%	<i>G</i>	%	Total abs. yield% <sup>c</sup>
(0.59)	D <sub>2</sub> (760)	—	(1.74)	(1.32)	64	(0.75)	16	69
(0.57)	D <sub>2</sub> (760)	3	(1.72)	(0.54)	<b>77</b>	(0.21)	<b>23</b>	25
Condensed phase					<b>57</b>		<b>43</b>	
0.2 N H <sub>2</sub> SO <sub>4</sub> /MeOH					<b>63</b>		<b>37</b>	
10 M LiClO <sub>4</sub> /MeOH								

<sup>a</sup> O<sub>2</sub>: 4 Torr, radiation dose 1.5 × 10<sup>4</sup> Gy (dose rate 1 × 10<sup>4</sup> Gy h<sup>-1</sup>).

<sup>b</sup> *G* values expressed as the number of molecules produced per 100 eV absorbed energy.

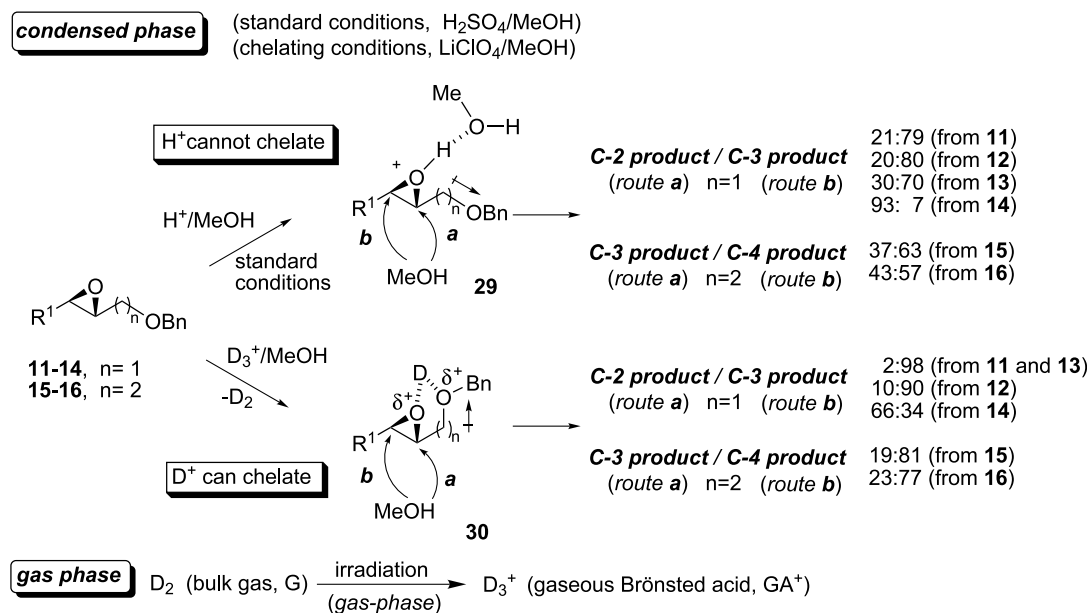
<sup>c</sup> Total absolute yields (%) estimated from the percentage ratio of the combined *G*(M) values of products and the literature *G*(GA<sup>+</sup>) values.<sup>14</sup>

decoupling experiments carried out on the corresponding acetyl derivatives.<sup>11,12</sup>

### 3. Discussion

Epoxides **11–16** were subjected to ring-opening reaction with MeOH in the condensed [standard (0.2 N H<sub>2</sub>SO<sub>4</sub>/

MeOH) and chelating conditions (10 N LiClO<sub>4</sub>/MeOH)] and in the gas phase (D<sub>3</sub><sup>+</sup>/MeOH in D<sub>2</sub>).<sup>13</sup> The results obtained in these different reaction conditions are reported in Tables 1–3. The results obtained in the condensed phase under standard conditions with epoxides **11–16** form the necessary starting point to understand the behavior of these oxirane systems, on the reasonable assumption, based on previous observations,<sup>7</sup> that under these conditions the



Scheme 3.

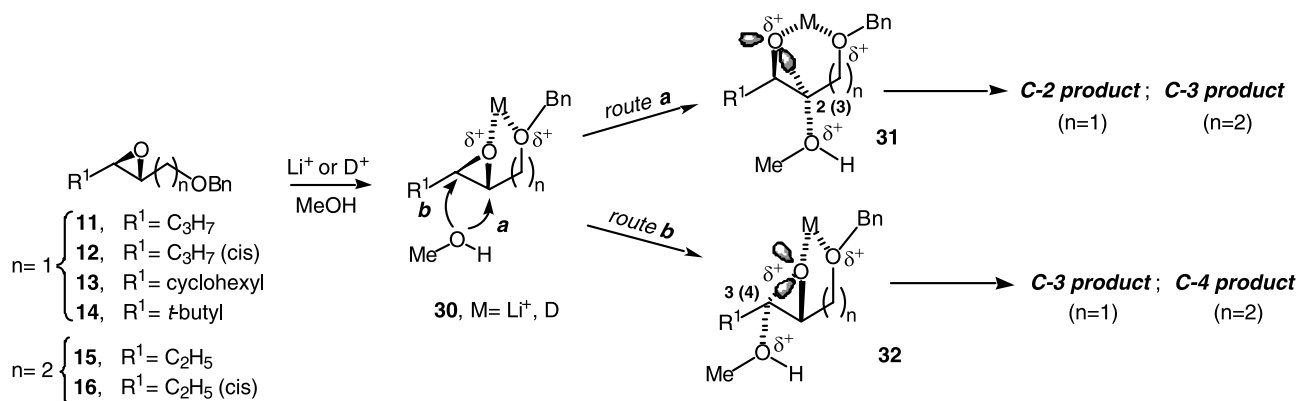
proton is devoid of any chelating ability (Scheme 3). In these conditions, the regioselectivity observed shows in all cases but one (epoxide **14**), that the *C*-3 product in the allylic epoxides **11–13** and the *C*-4 product in the homoallylic ones **15–16** prevail over the regioisomeric *C*-2- and *C*-3-product, respectively. This type of regioselectivity is justified by the presence of the terminal functionality (–OBn) and the related inductive electron-withdrawing effect which favors the nucleophilic attack on the further C(3) (in epoxides **11–13**) and C(4) oxirane carbon (in epoxides **15–16**) (route *b*, Scheme 3). The only reasonable exception is provided by the *t*-butyl derivative **14** in which the strong steric effect exerted by the *t*-butyl group makes the nucleophilic attack occur on the less hindered C(2) oxirane carbon, even if this is disfavored by the electronic effect of the heterofunctionality, to give a high C(2)-regioselectivity (93%) (route *a*, Scheme 3 and Tables 1–3).

The same methanolysis reactions were repeated under chelating conditions (MeOH/LiClO<sub>4</sub>). In all the oxirane systems examined, a constant increase is observed in the C(3)-regioselectivity in **11–13** (from 70–80 to 84–87%) and **14** (from 7 to 18%)<sup>9</sup> and the C(4)-regioselectivity in **15–16** (from 57–63 to 63–68%) (Tables 1–3).

With these results available, having clarified the behavior of these epoxides in the condensed phase (standard and chelating conditions), we examined the behavior and the regioselectivity of the same epoxides under gas phase operating conditions, that is, in conditions in which, as a result of the absence of the protic solvent (MeOH), conditions are suitable for the proton, actually D<sup>+</sup> (derived from D<sub>3</sub><sup>+</sup> which is generated by irradiation of the bulk gas D<sub>2</sub>, Scheme 3),<sup>6</sup> to exert a chelating activity, if this is allowed by the conformational constraints of the substrate. As a different product distribution is obtained in D<sub>2</sub> as a function of the experimental conditions [low or high bulk gas (D<sub>2</sub>) pressure] and the presence or absence of NMe<sub>3</sub>,<sup>7</sup> the reactions were carried out in conditions of low ion-lifetime, that is, under high pressure and in the presence of NMe<sub>3</sub>; these conditions are more similar to the condensed phase operating conditions and, as a consequence, are more appropriate for an effective comparison between the results obtained in the condensed and gas phase (Tables 1–3, bolded results). In fact, in the condensed phase, the

intermediate protonated epoxide **29** (Scheme 3) rapidly undergoes nucleophilic addition by the surrounding nucleophilic solvent (MeOH) to afford the corresponding opening products, a situation which actually corresponds to low ion-lifetime conditions in the gas phase.<sup>7</sup>

The results obtained in the methanolysis reaction carried out under these operating conditions show that in all 2,3- and 3,4-epoxides, whatever the substitution on the oxirane ring, an increase of nucleophilic attack on the oxirane C(3) and C(4) carbons is respectively observed, to give a corresponding C(3)- (98% in **11** and **13**, 90% in **12**, and 34% in **14**) and C(4)-regioselectivity (81% in **15** and 77% in **16**) (Scheme 3), which turned out to be superior to that observed in the condensed phase, not only under standard (H<sup>+</sup>/MeOH), but also under chelating reaction conditions (LiClO<sub>4</sub>/MeOH) (Tables 1–3).<sup>15</sup> In this framework, the almost complete C-3 regioselectivity (98%) observed with *trans* epoxides **11** and **13** is remarkable, considering that such a selectivity has never been observed before in these aliphatic oxirane system in the reaction with MeOH under proton acid catalysis.<sup>3a,9</sup> The increased attack of the nucleophile on the oxirane carbon further away from the heterofunctionality (OBn) found in the condensed phase under chelating conditions, and even more so in the gas phase, can be justified on the basis of the incursion of chelated bidentate species such as **30** (*n* = 1, 2) (Scheme 4, only the *trans* forms are shown for simplicity), in which the proton, in the gas phase, or the metal, Li<sup>+</sup>, in the condensed phase (M = D or Li<sup>+</sup>, respectively) is bridge-type between the oxirane and the heterofunctionality oxygens. Subsequent nucleophilic attack by MeOH on the chelated species will occur preferentially at C(3), in the case of epoxides **11–13** (route *b*), because in this case the development of the lone pairs of the oxygen deriving from the breaking of the C(3)–O oxirane bond will occur outside the C(1)–C(2)–O–M–O 5-terminus ring, as shown in **31**, *n* = 1 (Scheme 4). In the alternative nucleophilic attack on C(2) of the intermediate chelated bidentate species **30** (route *a*), the corresponding oxygen lone pair deriving from the breaking of the C(2)–O oxirane bond develops inside the residual C(1)–C(2)–C(3)–O–M–O 6-terminus ring, as shown in **31**, *n* = 1 (Scheme 4), to give a situation of higher energy content. Similar electronic considerations can be made in the case of epoxides **15** and **16** in order to justify a preferential nucleophilic attack on the C(4) (route *b*) than on



Scheme 4.

the C(3) (route **a**) of the corresponding chelated structures **30**,  $n=2$  (Scheme 4).

The efficiency of the gas phase protocol in order to rouse the chelating ability of proton and, as a consequence, to force nucleophilic attack on the oxirane carbon further from the heterofunctionality in these open chain *O*-functionalized epoxides, is clearly demonstrated by the behavior of the *t*-butyl-substituted epoxide **14**, in which the observed C-3 selectivity, even if lower than the corresponding C-2 selectivity, is decidedly appreciable (34%), considering the steric hindrance around the C(3) oxirane carbon, as demonstrated by the corresponding low value obtained under standard conditions (7%, Table 2 and Scheme 3). Also the decided C-4 regioselectivity (77–81%) observed in epoxides **15** and **16**, in which the inductive electron-withdrawing effect of the terminal OBn group is reasonably less active, helps to demonstrate the validity of the given rationalization based on the incursion of chelated bidentate species and related electronic factors associated with their way of opening.

All these results confirm that in the gas phase,  $D^+$  is an excellent chelating species for *O*-functionalized oxiranes, and that this chelating activity is not limited to fused systems but can also be exerted in open, non-fused oxirane systems. As a consequence, the chelating ability of  $D^+$ , at least in the gas phase, can reasonably be considered to be an intrinsic property of  $D^+$ , which turns out to be even superior than found in the condensed phase for  $Li^+$ , whose considerable chelating ability is well-known and has repeatedly been observed.<sup>3</sup>

#### 4. Conclusions

In conclusion, we have verified that in the gas phase operating conditions, without the complicating interference of the solvent and counterion effects, it is possible to observe the incursion of intramolecular chelating processes mediated by the proton (actually  $D^+$ )<sup>6</sup> in opening reactions with MeOH, in the presence of a gaseous acid ( $GA^+ = D_3^+$ ), of a series of open chain epoxides bearing a heterofunctionality in an allylic or homoallylic relationship to the oxirane ring. All the epoxides examined (**11–16**) showed in the gas phase a regioselectivity towards the oxirane carbon further from the heterofunctionality, by means of an electronically favored nucleophilic attack on the corresponding chelated bidentate proton bridge-type intermediate species, decidedly superior to that obtained in the condensed phase under chelating conditions promoted by  $LiClO_4$ . These results indicate that the proton, which exhibits no efficacy in the condensed phase as a chelating agent, possesses in the opening reactions of *O*-functionalized epoxides and independently on their structure, intrinsic chelating properties in the gas phase even superior to those of  $Li^+$  in the condensed phase.

#### 5. Experimental

##### 5.1. General

$^1H$  and  $^{13}C$  NMR spectra were determined with a Bruker AC

200 spectrometer on a  $CDCl_3$  solution using tetramethylsilane as the internal standard. IR spectra for comparison between compounds were taken with a Mattson 3000 FTIR spectrophotometer. All reactions were followed by TLC on Alugram SIL G/UV254 silica gel sheets (Machery–Nagel) with detection by UV. Preparative TLC was performed on 2.0 or 0.5 mm Machery–Nagel DC-Fertigplatten UV254 silica gel plates. Epoxides **11–16** were prepared as previously described.<sup>9,10</sup>

Epoxide **11**:  $^{13}C$ NMR  $\delta$  138.3, 128.6, 127.9, 73.4, 70.7, 57.1, 56.0, 33.9, 19.5, 14.2. MS ( $m/z$ ) 57, 65, 79, 91, 107, 206 ( $M^+$ ). Epoxide **12**:  $^{13}C$  NMR  $\delta$  138.4, 128.9, 128.3, 73.8, 68.8, 56.5, 55.7, 30.6, 20.5, 14.5. MS ( $m/z$ ) 57, 65, 79, 91, 107, 206 ( $M^+$ ). Epoxide **13**:  $^{13}C$  NMR  $\delta$  138.5, 128.9, 128.2, 73.6, 71.1, 60.8, 56.3, 40.1, 34.1, 29.5, 26.2. MS ( $m/z$ ) 55, 67, 81, 91, 107, 246 ( $M^+$ ). Epoxide **14**:  $^{13}C$  NMR  $\delta$  138.4, 128.9, 128.2, 73.6, 71.2, 64.2, 54.5, 31.1, 26.3. MS ( $m/z$ ) 55, 57, 70, 91, 107, 220 ( $M^+$ ). Epoxide **15**:  $^{13}C$  NMR  $\delta$  138.7, 128.8, 128.0, 127.3, 73.5, 67.5, 60.4, 56.6, 33.1, 25.5, 10.3. MS ( $m/z$ ) 41, 65, 91, 107, 159, 206 ( $M^+$ ). Epoxide **16**:  $^{13}C$  NMR  $\delta$  138.6, 128.6, 127.7, 73.2, 67.8, 58.2, 54.9, 28.6, 21.4, 10.7. MS ( $m/z$ ) 41, 65, 91, 107, 159, 206 ( $M^+$ ).

##### 5.1.1. Acid-catalyzed methanolysis of epoxides **11–16**.

**Typical procedure.** The *trans* epoxide **15** (0.10 g, 0.48 mmol) was added to 0.2 N  $H_2SO_4$  in anhydrous MeOH (5.0 mL), and the reaction mixture was stirred for 1 h at rt. Dilution with ether, and evaporation of the washed (saturated aqueous  $NaHCO_3$ , and water) organic solution afforded a crude reaction mixture (0.108 g, 94% yield) consisting of a 37:63 mixture ( $^1H$  NMR, GC) of regioisomeric HEs **25** and **26** (see Table 3) which was subjected to preparative TLC (a 9:1:0.1 hexane/AcOEt/MeOH mixture was used as the eluant). Extraction of the two most intense bands (the faster moving band contained **26**) afforded pure HEs **26** (0.051 g, 44% yield) and **25** (0.034 g, 29% yield).

*anti*-1-(Benzyloxy)-3-hydroxy-4-methoxyhexane (**26**). A liquid (Found: C, 70.19; H, 8.97.  $C_{14}H_{22}O_3$  requires: C, 70.56; H, 9.3): IR  $\nu$  3439  $cm^{-1}$  (OH);  $^1H$  NMR  $\delta$  7.25–7.38 (m, 5H), 4.53 (s, 2H), 3.82–3.90 (m, 1H), 3.60–3.79 (m, 2H), 3.40 (s, 3H), 3.04 (dt, 1H,  $J=6.8, 4.9$  Hz), 1.72–1.83 (m, 2H), 1.48–1.68 (m, 2H), 0.94 (t, 3H,  $J=7.3$  Hz).  $^{13}C$  NMR  $\delta$  138.6, 128.9, 128.2, 85.8, 73.8, 71.6, 69.6, 58.6, 32.4, 22.5, 10.3. MS ( $m/z$ ) 45, 65, 73, 91, 165, 238 ( $M^+$ ).

*anti*-1-(Benzyloxy)-4-hydroxy-3-methoxyhexane (**25**). A liquid (Found: C, 70.77; H, 9.51.  $C_{14}H_{22}O_3$  requires: C, 70.56; H, 9.3): IR  $\nu$  3446  $cm^{-1}$  (OH);  $^1H$  NMR  $\delta$  7.26–7.33 (m, 5H), 4.55 (d, 1H,  $J=11.7$  Hz), 4.48 (d, 1H,  $J=11.7$  Hz), 3.51–3.70 (m, 3H), 3.35 (s, 3H), 3.26 (dd, 1H,  $J=10.2, 5.4$  Hz), 1.83 (dd, 2H,  $J=11.7, 5.8$  Hz), 1.39–1.55 (m, 2H), 0.99 (t, 3H,  $J=7.5$  Hz).  $^{13}C$  NMR  $\delta$  138.9, 128.9, 128.2, 81.9, 73.6, 73.4, 67.2, 58.1, 29.3, 26.0, 11.1. MS ( $m/z$ ) 59, 72, 73, 91, 117, 238 ( $M^+$ ).

Application of the same procedure to *trans* epoxide **11** (0.10 g, 0.48 mmol) afforded a crude liquid product (0.106 g, 93% yield) consisting of a 21:79 mixture ( $^1H$  NMR, GC) of regioisomeric HEs **17** and **18** (see Table 1),

which was subjected to preparative TLC (a 9:1:0.1 hexane/AcOEt/MeOH mixture was used as the eluant). Extraction of the two most intense bands (the faster moving band contained **18**) afforded pure HEs **18** (0.060 g, 52% yield) and **17** (0.007 g, 6% yield).

*anti-1-(Benzyloxy)-2-hydroxy-3-methoxyhexane (18)*. A liquid (Found: C, 70.45; H, 9.09.  $C_{14}H_{22}O_3$  requires: C, 70.56; H, 9.3): IR  $\nu$  3445  $cm^{-1}$  (OH);  $^1H$  NMR  $\delta$  7.26–7.36 (m, 5H), 4.56 (s, 2H), 3.82–3.90 (m, 1H), 3.46–3.67 (m, 2H), 3.38 (s, 3H), 3.19–3.28 (m, 1H), 1.26–1.57 (m, 4H), 0.93 (t, 3H,  $J=6.8$  Hz).  $^{13}C$  NMR  $\delta$  138.5, 129.0, 128.4, 82.2, 74.0, 72.1, 71.7, 58.8, 32.7, 19.1, 14.8. MS ( $m/z$ ) 45, 87, 91, 107, 163, 238 ( $M^+$ ).

*anti-1-(Benzyloxy)-3-hydroxy-2-methoxyhexane (17)*. A liquid (Found: C, 70.72; H, 9.46.  $C_{14}H_{22}O_3$  requires: C, 70.56; H, 9.3): IR  $\nu$  3431  $cm^{-1}$  (OH);  $^1H$  NMR  $\delta$  7.25–7.32 (m, 5H), 4.54 (s, 2H), 3.77–3.80 (m, 1H), 3.64 (d, 2H,  $J=4.9$  Hz), 3.45 (s, 3H), 3.26 (dd, 1H,  $J=9.3, 4.9$  Hz), 1.25–1.63 (m, 4H), 0.91 (t, 3H,  $J=6.8$  Hz).  $^{13}C$  NMR  $\delta$  138.5, 129.0, 128.3, 83.3, 74.2, 72.2, 70.1, 58.8, 35.6, 19.7, 14.7. MS ( $m/z$ ) 58, 65, 79, 91, 107, 238 ( $M^+$ ).

Application of the same procedure to *cis* epoxide **12** (0.10 g, 0.48 mmol) afforded a crude liquid product (0.106 g, 93% yield) consisting of a 20:80 mixture ( $^1H$  NMR, GC) of regioisomeric HEs **19** and **20** (see Table 1), which turned out to be unseparable by any chromatographic techniques.

Application of the same procedure to *trans* epoxide **13** (0.10 g, 0.41 mmol) afforded a crude liquid product (0.11 g, 96% yield) consisting of a 30:70 mixture ( $^1H$  NMR, GC) of regioisomeric HEs **21** and **22** (see Table 2), which was subjected to preparative TLC (a 9:1 hexane/AcOEt mixture was used as the eluant). Extraction of the two most intense bands (the faster moving band contained **22**) afforded pure HEs **22** (0.042 g, 37% yield) and **21** (0.017 g, 15% yield).

*anti-1-(Benzyloxy)-3-cyclohexyl-2-hydroxy-3-methoxypropane (22)*. A liquid (Found: C, 72.94; H, 9.10.  $C_{17}H_{26}O_3$  requires: C, 73.35; H, 9.41): IR  $\nu$  3438  $cm^{-1}$  (OH);  $^1H$  NMR  $\delta$  7.28–7.36 (m, 5H), 4.56 (s, 2H), 3.66–3.73 (m, 2H), 3.36–3.63 (m, 2H), 3.44 (s, 3H), 0.98–1.71 (m, 11H).  $^{13}C$  NMR  $\delta$  138.5, 128.9, 128.3, 80.8, 76.1, 74.2, 69.8, 58.3, 40.2, 29.9, 29.0, 27.0, 26.7, 26.5. MS ( $m/z$ ) 45, 65, 91, 95, 127, 278 ( $M^+$ ).

*anti-1-(Benzyloxy)-3-cyclohexyl-3-hydroxy-2-methoxypropane (21)*. A liquid (Found: C, 73.54; H, 9.67.  $C_{17}H_{26}O_3$  requires: C, 73.35; H, 9.41): IR  $\nu$  3440  $cm^{-1}$  (OH);  $^1H$  NMR  $\delta$  7.19–7.28 (m, 5H), 4.49 (s, 2H), 3.75–3.98 (m, 1H), 3.64–3.62 (m, 2H), 3.34 (s, 3H), 2.92 (dd, 1H,  $J=6.4, 4.5$  Hz), 1.09–1.74 (m, 11H).  $^{13}C$  NMR  $\delta$  138.6, 129.0, 128.4, 86.9, 74.0, 72.0, 71.2, 61.5, 40.2, 30.8, 28.0, 27.1, 26.9. MS ( $m/z$ ) 58, 59, 91, 107, 108, 278 ( $M^+$ ).

Application of the same procedure to *trans* epoxide **14** (0.10 g, 0.45 mmol) afforded a crude liquid product (0.107 g, 94% yield) consisting of a 93:7 mixture ( $^1H$  NMR, GC) of regioisomeric HEs **23** and **24** (see Table 2) which was subjected to preparative TLC (a 9:1 hexane/AcOEt mixture was used as the eluant). Extraction of the

two most intense bands (the faster moving band contained **24**) afforded pure HEs **24** (0.002 g, 2% yield) and **23** (0.023 g, 20% yield).

*anti-1-(Benzyloxy)-2-hydroxy-3-methoxy-4,4-dimethylpentane (24)*. A liquid (Found: C, 71.20; H, 9.32.  $C_{15}H_{24}O_3$  requires: C, 71.39; H, 9.59): IR  $\nu$  3439  $cm^{-1}$  (OH);  $^1H$  NMR  $\delta$  7.29–7.36 (m, 5H), 4.58 (s, 2H), 3.55–3.77 (m, 3H), 3.46 (s, 3H), 2.91 (d, 1H,  $J=4.9$  Hz), 0.95 (s, 9H).  $^{13}C$  NMR  $\delta$  138.7, 129.1, 128.7, 128.4, 91.3, 74.1, 72.8, 72.3, 67.8, 62.3, 27.2. MS ( $m/z$ ) 41, 69, 91, 101, 177, 252 ( $M^+$ ).

*anti-1-(Benzyloxy)-3-hydroxy-2-methoxy-4,4-dimethylpentane (23)*. A liquid (Found: C, 71.65; H, 9.74.  $C_{15}H_{24}O_3$  requires: C, 71.39; H, 9.59): IR  $\nu$  3441  $cm^{-1}$  (OH);  $^1H$  NMR  $\delta$  7.28–7.35 (m, 5H), 4.57 (s, 2H), 3.62–3.82 (m, 2H), 3.44–3.49 (m, 1H), 3.36 (s, 3H), 2.74 (d, 1H,  $J=4.1$  Hz), 0.94 (s, 9H).  $^{13}C$  NMR  $\delta$  138.4, 129.0, 128.4, 81.3, 80.5, 74.3, 70.2, 57.4, 35.0, 26.9. MS ( $m/z$ ) 58, 59, 91, 99, 107, 252 ( $M^+$ ).

Application of the same procedure to *cis* epoxide **16** (0.10 g, 0.48 mmol) afforded a crude liquid product (0.112 g, 98% yield) consisting of a 43:57 mixture ( $^1H$  NMR, GC) of regioisomeric HEs **27** and **28** (see Table 3), which was subjected to preparative TLC (a 9:1:0.1 hexane/AcOEt/MeOH mixture was used as the eluant). Extraction of the two most intense bands (the faster moving band contained **28**) afforded pure HEs **28** (0.046 g, 40% yield) and **27** (0.044 g, 38% yield).

*syn-1-(Benzyloxy)-3-hydroxy-4-methoxyhexane (28)*. A liquid (Found: C, 70.84; H, 9.62.  $C_{14}H_{22}O_3$  requires: C, 70.56; H, 9.3): IR  $\nu$  3441  $cm^{-1}$  (OH);  $^1H$  NMR  $\delta$  7.29–7.35 (m, 5H), 4.53 (s, 2H), 3.78 (dd, 1H,  $J=12.2, 5.4$  Hz), 3.68 (td, 2H,  $J=6.3, 2.4$  Hz), 3.41 (s, 3H), 2.98 (dd, 1H,  $J=11.7, 5.4$  Hz), 1.78 (dd, 2H,  $J=12.2, 6.3$  Hz), 1.43–1.69 (m, 2H), 0.93 (t, 3H,  $J=7.4$  Hz).  $^{13}C$  NMR  $\delta$  138.8, 128.9, 128.2, 85.8, 73.7, 71.0, 68.8, 58.7, 33.5, 22.8, 10.1. MS ( $m/z$ ) 45, 65, 73, 91, 165, 238 ( $M^+$ ).

*syn-1-(Benzyloxy)-4-hydroxy-3-methoxyhexane (27)*. A liquid (Found: C, 70.12; H, 9.20.  $C_{14}H_{22}O_3$  requires: C, 70.56; H, 9.3): IR  $\nu$  3441  $cm^{-1}$  (OH);  $^1H$  NMR  $\delta$  7.27–7.35 (m, 5H), 4.51 (s, 2H), 3.58 (t, 2H,  $J=6.3$  Hz), 3.36–3.44 (m, 1H), 3.41 (s, 3H), 3.25 (dd, 1H,  $J=11.5, 5.1$  Hz), 1.71–2.01 (m, 2H), 1.39–1.66 (m, 2H), 0.98 (t, 3H,  $J=7.3$  Hz).  $^{13}C$  NMR  $\delta$  138.8, 128.9, 128.2, 81.7, 75.0, 73.6, 67.1, 59.2, 31.3, 26.8, 10.7. MS ( $m/z$ ) 59, 72, 73, 91, 117, 238 ( $M^+$ ).

**5.1.2. Acetylation of HEs 25–28. Typical procedure.** HE **26** (0.018 g, 0.075 mmol) in anhydrous pyridine (0.4 mL) was treated at 0 °C with  $Ac_2O$  (0.2 mL) and then left for 24 h at rt. Ice was added, and after 5 h, dilution with water, extraction with ether, and evaporation of the washed (water, 10% aqueous HCl, saturated aqueous  $NaHCO_3$ , and water) ether extracts afforded pure *anti-3-acetoxy-1-(benzyloxy)-4-methoxyhexane (26-Ac)* (0.020 g, 94% yield), as a liquid (Found: C, 68.32; H, 8.46.  $C_{16}H_{24}O_4$  requires: C, 68.55; H, 8.63): IR  $\nu$  1734  $cm^{-1}$  (C=O);  $^1H$  NMR  $\delta$  7.27–7.37 (m, 5H), 5.18 (td, 1H,  $J=6.5, 3.2$  Hz), 4.51 (d, 1H,  $J=12.0$  Hz), 4.45 (d, 1H,  $J=12.0$  Hz), 3.43–3.59 (m, 2H), 3.40 (s, 3H), 3.17 (td, 1H,  $J=6.3, 3.2$  Hz), 2.01 (s, 3H), 1.92 (d, 1H,

$J=6.3$  Hz), 1.86 (d, 1H,  $J=6.3$  Hz), 1.41–1.58 (m, 2H), 0.96 (t, 3H,  $J=7.4$  Hz).  $^{13}\text{C}$  NMR  $\delta$  171.3, 138.9, 128.9, 128.3, 128.1, 84.5, 73.7, 72.6, 67.3, 59.1, 30.1, 23.9, 21.8, 10.8.

Application of the same procedure to HE **25** (0.018 g, 0.075 mmol) afforded pure *anti-4-acetoxy-1-(benzylloxy)-3-methoxyhexane (25-Ac)* (0.019 g, 90% yield), as a liquid (Found: C, 68.75; H, 8.91.  $\text{C}_{16}\text{H}_{24}\text{O}_4$  requires: C, 68.55; H, 8.63): IR  $\nu$  1738  $\text{cm}^{-1}$  (C=O);  $^1\text{H}$  NMR  $\delta$  7.27–7.38 (m, 5H), 5.03 (ddd, 1H,  $J=8.1, 5.2, 3.1$  Hz), 4.54 (d, 1H,  $J=12.0$  Hz), 4.47 (d, 1H,  $J=12.0$  Hz), 3.58 (dd, 2H,  $J=7.2, 5.2$  Hz), 3.38–3.44 (m, 1H), 3.36 (s, 3H), 2.06 (s, 3H), 1.68–1.92 (m, 2H), 1.48–1.67 (m, 2H), 0.90 (t, 3H,  $J=7.4$  Hz).  $^{13}\text{C}$  NMR  $\delta$  171.4, 138.9, 128.9, 128.3, 128.2, 78.7, 76.4, 73.6, 67.1, 59.6, 31.2, 23.4, 21.6, 10.6.

Application of the same procedure to HE **28** (0.015 g, 0.063 mmol) afforded pure *syn-3-acetoxy-1-(benzylloxy)-4-methoxyhexane (28-Ac)* (0.017 g, 96% yield), as a liquid (Found: C, 68.28; H, 8.39.  $\text{C}_{16}\text{H}_{24}\text{O}_4$  requires: C, 68.55; H, 8.63): IR  $\nu$  1740  $\text{cm}^{-1}$  (C=O);  $^1\text{H}$  NMR  $\delta$  7.27–7.37 (m, 5H), 5.20 (ddd, 1H,  $J=3.6, 5.3, 7.8$  Hz), 4.48 (s, 2H), 3.44–3.56 (m, 2H), 3.41 (s, 3H), 3.11 (ddd, 1H,  $J=3.6, 6.1, 6.8$  Hz), 1.86–2.13 (m, 2H), 2.03 (s, 3H), 1.39–1.59 (m, 2H), 0.93 (t, 3H,  $J=7.4$  Hz).  $^{13}\text{C}$  NMR  $\delta$  171.3, 138.9, 128.9, 128.3, 128.2, 83.7, 73.7, 71.7, 67.5, 59.2, 30.9, 23.3, 21.7, 10.7.

Application of the same procedure to HE **27** (0.012 g, 0.050 mmol) afforded pure *syn-4-acetoxy-1-(benzylloxy)-3-methoxyhexane (27-Ac)* (0.013 g, 93% yield), as a liquid (Found: C, 68.83; H, 8.97.  $\text{C}_{16}\text{H}_{24}\text{O}_4$  requires: C, 68.55; H, 8.63): IR  $\nu$  1736  $\text{cm}^{-1}$  (C=O);  $^1\text{H}$  NMR  $\delta$  7.27–7.36 (m, 5H), 4.88 (ddd, 1H,  $J=8.4, 4.7, 3.9$  Hz), 4.49 (s, 2H), 3.50–3.62 (m, 2H), 3.41–3.48 (m, 1H), 3.40 (s, 3H), 2.06 (s, 3H), 1.54–1.80 (m, 4H), 0.89 (t, 3H,  $J=7.4$  Hz).  $^{13}\text{C}$  NMR  $\delta$  171.4, 139.1, 128.9, 128.3, 128.1, 79.7, 75.9, 73.6, 67.3, 58.7, 31.1, 23.5, 21.5, 10.7.

## 5.2. Methanolysis of epoxides 11–16 in the presence of $\text{LiClO}_4$ . General procedure

The epoxide (0.24 mmol) was added to 10 M  $\text{LiClO}_4$  in anhydrous MeOH (0.48 mL), and the reaction mixture was stirred at 70 °C for 18 h. Dilution with ether and evaporation of the washed (water) organic solution afforded a crude reaction mixture which was analyzed by GC and  $^1\text{H}$  NMR to give the results shown in Tables 1–3.

## 5.3. Reactions in the gas-phase

**5.3.1. Materials.** Oxygen and trimethylamine were high-purity gases from Matheson Gas Products Inc., deuterium (99.98%) was purchased from Aldrich and all were used without further purification. The chemical purity of the starting oxirane substrates was verified by analytical gas chromatography on the same columns used for the analysis of their gas phase products.

**5.3.2. Procedure.** The gaseous mixtures were prepared by conventional procedures with the use of a greaseless vacuum line. The selected epoxy derivative (0.007–0.009 mmol), the methanol (0.021–0.026 mmol), the thermal radical scavenger  $\text{O}_2$ , and the trimethylamine

were introduced into carefully outgassed 250 mL Pyrex bulbs, each equipped with a break-seal arm. The bulbs were filled with  $\text{D}_2$ , and were then allowed to come to room temperature; the fragile ampoules were broken, and the gaseous components were allowed to mix before being subjected to the irradiation. The gaseous mixtures were submitted to irradiation at a constant temperature (37.5 °C) in a  $^{60}\text{Co}$  220 Gammacell from Nuclear Canada Ltd. (dose:  $1.5 \times 10^4$  Gy; dose rate:  $1 \times 10^4$  Gy  $\text{h}^{-1}$ , determined with a Fricke dosimeter). Control experiments, carried out at doses ranging from  $1 \times 10^4$  to  $1 \times 10^5$  Gy, showed that the relative yields of products are largely independent of the dose. In order to verify the stability of the reaction products, the HEs **17–28** were placed with the gaseous members ( $\text{D}_2$ ,  $\text{O}_2$ , and  $\text{NMe}_3$ ) into Pyrex bulbs and irradiated at the same experimental conditions adopted for the corresponding epoxides (37.5 °C—dose:  $1.5 \times 10^4$  Gy). In all cases, the HEs **17–28** were recovered unchanged and no trace of isomerization products was found.

**5.3.3. Product analysis.** The radiolytic products were analyzed by injecting measured portions of the homogeneous reaction mixture into a Hewlett–Packard 5890 series II gas chromatograph, equipped with a flame ionization detector. In order to prevent selective loss of the reaction products by adsorption on the glass of the reaction bulb (and to obtain reproducible and meaningful reaction yields), the analysis was repeated after careful washing of the bulb walls with anhydrous ether. Satisfactory agreement between the results of the gaseous mixture and the ether solution analysis was found in all runs. The products were identified by comparison of their retention volumes with those of authentic reference compounds on the following columns: (i) a 50 m long, 0.31 mm i.d. Ultra<sup>TM</sup> crosslinked methyl silicone fused silica capillary column, operating at temperatures ranging from 100 to 210 °C, 5 °C  $\text{min}^{-1}$ ; (ii) a 30 m long, 0.32 mm i.d. Supelcowax 10<sup>TM</sup> fused silica capillary column, operating at 190 °C. The identity of the products was further confirmed by GLC-MS, using a Hewlett–Packard 5890A gas chromatograph in line with a HP 5971A quadrupole mass spectrometer. Their yields were determined from the areas of the corresponding eluted peaks, using the internal standard method and individual calibration factors to correct for the detector response. The results given in the Tables 1–3 are the average of at least three measurements taken on at least two different runs for each point.

## Acknowledgements

This work was supported by the Università di Pisa and MIUR (Ministero dell'Istruzione, della Università e della Ricerca) Roma. P.C. gratefully acknowledges Merck Research Laboratories for the generous financial support deriving from the 2002 ADP Chemistry Award.

## References and notes

1. Gorzynski Smith, J. *Synthesis* **1984**, 629–656.

2. (a) Caron, M.; Sharpless, K. B. *J. Org. Chem.* **1985**, *50*, 1557–1560. (b) Behrens, C. H.; Sharpless, K. B. *J. Org. Chem.* **1985**, *50*, 5696–5704. (c) Caron, M.; Carlier, P. R.; Sharpless, K. B. *J. Org. Chem.* **1988**, *53*, 5185–5187.
3. (a) Chini, M.; Crotti, P.; Flippin, L. A.; Macchia, F. *J. Org. Chem.* **1990**, *55*, 4265–4272. (b) Chini, M.; Crotti, P.; Flippin, L. A.; Macchia, F. *J. Org. Chem.* **1991**, *56*, 7043–7048. (c) Chini, M.; Crotti, P.; Gardelli, C.; Macchia, F. *J. Org. Chem.* **1994**, *59*, 4131–4137. (d) Calvani, F.; Crotti, P.; Gardelli, C.; Pineschi, M. *Tetrahedron* **1994**, *50*, 12999–13021 and references therein.
4. Standard reaction conditions: epoxide opening reactions carried out with the nucleophile under protic acid catalysis, or without any catalysis in an appropriate solvent (MeOH/H<sub>2</sub>SO<sub>4</sub> and MeONa/MeOH, respectively, in the methanolysis). Chelating reaction conditions: epoxide opening reactions carried with the nucleophile in the presence of a metal salt (MeOH/LiClO<sub>4</sub>, in the methanolysis).
5. The *C-1* and *C-2 product*, the *C-2* and *C-3 product*, and the *C-3* and *C-4 product* nomenclature refers to the attacking site of the nucleophile, i.e. at the C(1) or C(2), the C(2) or C(3), or the C(3) or C(4) oxirane carbons of epoxides **1–4** and **11–16**, in accordance with the numbering scheme shown in Schemes 1–4.
6. In the gas phase, D<sup>+</sup> (actually D<sub>3</sub><sup>+</sup>) was used instead of H<sup>+</sup> simply for practical reasons (necessary purity of the corresponding bulk gas, D<sub>2</sub> and H<sub>2</sub>, respectively). However, in the opening reactions of epoxides **1–4** and **11–16** with MeOH, the behavior of D<sup>+</sup> is to be considered completely identical to that of H<sup>+</sup>, to the point that no difference is made in the discussion between them.
7. (a) Crotti, P.; Di Bussolo, V.; Favero, L.; Pineschi, M.; Marianucci, F.; Renzi, G.; Amici, G.; Roselli, G. *Tetrahedron* **2000**, *56*, 7513–7524. (b) Crotti, P.; Renzi, G.; Favero, L.; Roselli, G.; Di Bussolo, V.; Caselli, M. *Tetrahedron* **2003**, *59*, 1453–1467.
8. Methanolysis presents the unique advantage of offering a clear indication of the regioselectivity of the opening process and of being indifferently conducted both in the condensed phase (standard, H<sup>+</sup>/MeOH, or chelating conditions, MeOH/LiClO<sub>4</sub>) and in the gas phase (D<sub>3</sub><sup>+</sup>, MeOH), making a direct comparison possible of the behavior of the proton under different operating conditions.
9. Chini, M.; Crotti, P.; Flippin, L. A.; Gardelli, C.; Giovani, E.; Macchia, F.; Pineschi, M. *J. Org. Chem.* **1993**, *58*, 1221–1227.
10. Azzena, F.; Calvani, F.; Crotti, P.; Gardelli, C.; Macchia, F.; Pineschi, M. *Tetrahedron* **1995**, *51*, 10601–10626.
11. In the case of the inseparable HEs **19** and **20**, the corresponding *C-3 product* structure was assigned to the HE, actually HE **20**, present in a larger amount (80%) in the crude opening reaction product (0.2 N H<sub>2</sub>SO<sub>4</sub>/MeOH), on the basis of the unfavorable electron-withdrawing inductive effect of the terminal OBn group (see text).
12. The acetyl derivatives of HEs **17–24** have been previously described.<sup>9</sup>
13. Epoxides **11–16** were previously examined by the authors in opening reactions in the condensed phase with different nucleophiles (including MeOH in the case of **11–14**), both under standard and chelating conditions.<sup>9,10</sup>
14. (a) Ausloos, P.; Lias, S. G.; Gorden, R., Jr. *J. Chem. Phys.* **1963**, *39*, 3341–3348. (b) Ausloos, P. In *Ion-molecule reactions*; Franklin, J. L., Ed.; Plenum: New York, 1970. (c) Ausloos, P.; Lias, S. *J. Chem. Phys.* **1962**, *36*, 3163–3170. (d) Sandoval, I. B.; Ausloos, P. *J. Chem. Phys.* **1963**, *38*, 2454–2460. (e) Speranza, M.; Pepe, N.; Cipollini, R. *J. Chem. Soc., Perkin Trans. 2* **1979**, 1179–1186.
15. As in the condensed phase, no traces of non-addition products, but only the corresponding addition products (HEs) were found in the crude reaction products deriving from the acid-catalyzed opening reactions of epoxides **11–16** in the gas phase.